



General-Purpose AC Servo

**MELSERVO**

MODEL

**HF-MP**

**HF-KP**

**HF-SP**

**HA-LP**

**HC-RP**

**HC-UP**

**HC-LP**

**HF-JP**

**HG-AK**

SERVO MOTOR INSTRUCTION MANUAL (Vol.2)

# ● Safety Instructions ●

Please read the instructions carefully before using the equipment.

To use the equipment correctly, do not attempt to install, operate, maintain, or inspect the equipment until you have read through this Instruction Manual, Installation guide, Servo motor Instruction Manual (Vol. 2) and appended documents carefully. Do not use the servo amplifier and servo motor until you have a full knowledge of the equipment, safety information and instructions.

In this Instruction Manual, the safety instruction levels are classified into "WARNING" and "CAUTION".





Indicates that incorrect handling may cause hazardous conditions, resulting in death or severe injury.





Indicates that incorrect handling may cause hazardous conditions, resulting in medium or slight injury to personnel or may cause physical damage.

Note that the CAUTION level may lead to a serious consequence according to conditions. Please follow the instructions of both levels because they are important to personnel safety.

What must not be done and what must be done are indicated by the following diagrammatic symbols.

 : Indicates what must not be done. For example, "No Fire" is indicated by .

 : Indicates what must be done. For example, grounding is indicated by .

In this Instruction Manual, instructions at a lower level than the above, instructions for other functions, and so on are classified into "POINT".

After reading this Instruction Manual, keep it accessible to the operator.

1. To prevent electric shock, note the following

 **WARNING**

- Before wiring or inspection, turn off the power and wait for 15 minutes or more (20 minutes or for drive unit 30kW or more) until the charge lamp turns off. Then, confirm that the voltage between P(+) and N(–) (L+ and L– for drive unit 30kW or more) is safe with a voltage tester and others. Otherwise, an electric shock may occur. In addition, always confirm from the front of the converter unit and servo amplifier (drive unit), whether the charge lamp is off or not.
- Connect the converter unit, servo amplifier (drive unit) and servo motor to ground.
- Any person who is involved in wiring and inspection should be fully competent to do the work.
- Do not attempt to wire the converter unit, servo amplifier (drive unit) and servo motor until they have been installed. Otherwise, it may cause an electric shock.
- Operate the switches with dry hand to prevent an electric shock.
- The cables should not be damaged, stressed loaded, or pinched. Otherwise, it may cause an electric shock.
- During power-on or operation, do not open the front cover. Otherwise, it may cause an electric shock.
- Do not operate the converter unit and servo amplifier (drive unit) with the front cover removed. High-voltage terminals and charging area are exposed and you may get an electric shock.
- Except for wiring or periodic inspection, do not remove the front cover even if the power is off. The converter unit and servo amplifier (drive unit) are charged and you may get an electric shock.
- To prevent an electric shock, always connect the protective earth (PE) terminal (marked  $\oplus$ ) of the servo amplifier to the protective earth (PE) of the cabinet.
- When using a residual current device (RCD), select the type B.
- To avoid an electric shock, insulate the connections of the power supply terminals.

2. To prevent fire, note the following

 **CAUTION**

- Install the converter unit, servo amplifier (drive unit), servo motor and regenerative resistor on incombustible material. Installing them directly or close to combustibles will lead to a fire.
- When the converter unit and servo amplifier (drive unit) has become faulty, switch off the main converter unit and servo amplifier (drive unit) power side. Continuous flow of a large current may cause a fire.
- When a regenerative resistor is used, use an alarm signal to switch main power off.
- Provide adequate protection to prevent screws and other conductive matter, oil and other combustible matter from entering the converter unit and servo amplifier (drive unit) and servo motor.

3. To prevent injury, note the following

 **CAUTION**

- Only the voltage specified in the Instruction Manual should be applied to each terminal, Otherwise, a burst, damage, etc. may occur.
- Connect the terminals correctly to prevent a burst, damage, etc.
- Ensure that polarity (+, –) is correct. Otherwise, a burst, damage, etc. may occur.
- The converter unit and servo amplifier (drive unit) heat sink, regenerative resistor, servo motor, etc. may be hot while power is on or for some time after power-off. Take safety measures, e.g. provide covers, to prevent accidental contact of hands and parts (cables, etc.) with them.
- The surface temperature of the servo motor may exceed 100°C depending on its mounting and operating conditions.
- During operation, never touch the rotating parts of the servo motor. Otherwise, it may cause injury.

#### 4. Additional instructions

The following instructions should also be fully noted. Incorrect handling may cause a fault, injury, electric shock, etc.

##### (1) Transportation and installation

## ⚠ CAUTION

- Transport the products correctly according to their mass.
- Use eyebolt of the servo motor for the transportation purpose only. Do not use eyebolt to transport in the condition that the servo motor is installed on the machine.
- Stacking in excess of the specified number of products is not allowed.
- Do not carry the servo motor by the cables, shaft or encoder.
- Do not hold the front cover to transport the converter unit and servo amplifier (drive unit). The converter unit and servo amplifier (drive unit) may drop.
- Install the converter unit and servo amplifier (drive unit) in a load-bearing place in accordance with the Instruction Manual.
- Do not get on or put heavy load on the equipment.
- The servo motor must be installed in the specified direction.
- Leave specified clearances between the converter unit and servo amplifier (drive unit) and control enclosure walls or other equipment.
- Do not install or operate the servo amplifier (drive unit), converter unit and servo motor which has been damaged or has any parts missing.
- Do not block intake and exhaust areas of the converter unit, the servo amplifier (drive unit) and the servo motor with a cooling fan. Otherwise, it may cause a malfunction.
- Do not drop or strike the converter unit and servo amplifier (drive unit) and servo motor as they are precision equipment.
- When you keep or use it, please fulfill the following environmental conditions.

Environment			Conditions	
Ambient temperature	Operation	[°C]	0 to 40 (non-freezing)	
		[°F]	32 to 104 (non-freezing)	
	Storage	[°C]	-15 to 70 (non-freezing)	
		[°F]	5 to 158 (non-freezing)	
Ambient humidity	Operation		80%RH or less (non-condensing)	
	Storage		90%RH or less (non-condensing)	
Ambience			Indoors (no direct sunlight) Free from corrosive gas, flammable gas, oil mist, dust and dirt	
Altitude			Max. 1000m above sea level	
(Note) Vibration resistance	HF-MP series	HF-KP series	HG-AK series	X, Y: 49 m/s <sup>2</sup>
	HF-SP51 • 81 HF-SP52 to 152 HF-SP524 to 1524 HC-RP Series HC-UP72 • 152 HF-JP53 to 503 • 11K1M • 15K1M HF-JP534 to 5034 • 11K1M4 • 15K1M4			X, Y: 24.5 m/s <sup>2</sup>
	HF-SP121 • 201 HF-SP202 • 352 HF-SP2024 • 3524 HC-UP202 to 502			X: 24.5 m/s <sup>2</sup> Y: 49 m/s <sup>2</sup>
	HF-SP301 • 421 HF-SP502 • 702 HF-SP5024 • 7024 HF-JP703 • 903 HF-JP7034 • 9034			X: 24.5 m/s <sup>2</sup> Y: 29.4 m/s <sup>2</sup>
	HC-LP52 to 152			X: 9.8 m/s <sup>2</sup> Y: 24.5 m/s <sup>2</sup>
	HC-LP202 to 302			X: 19.6 m/s <sup>2</sup> Y: 49 m/s <sup>2</sup>
	HA-LP601 to 12K1 HA-LP701M to 15K1M HA-LP502 to 22K2 HA-LP6014 • 12K14 HA-LP701M4 • 15K1M4 HA-LP11K24 to 22K24			X: 11.7 m/s <sup>2</sup> Y: 29.4 m/s <sup>2</sup>
	HA-LP15K1 to 37K1 HA-LP22K1M to 37K1M HA-LP30K2 • 37K2 HA-LP15K14 to 37K14 HA-LP22K1M4 to 50K1M4 HA-LP30K24 to 55K24			X, Y: 9.8 m/s <sup>2</sup>

Note. Except the servo motor with a reduction gear.

## ⚠ CAUTION

- Securely attach the servo motor to the machine. If attach insecurely, the servo motor may come off during operation.
- The servo motor with a reduction gear must be installed in the specified direction to prevent oil leakage.
- Be sure to measure the motor vibration level with the servo motor mounted to the machine when checking the vibration level. A great vibration may cause the early damage of a bearing, encoder, brake, and reduction gear. The great vibration may also cause the poor connector connection or bolt looseness.
- For the gain adjustment at the equipment startup, check the torque waveform and the speed waveform by using a measurement device, and then check that no vibration occurs. If the vibration occurs due to high gain, the vibration may cause the early damage of the servo motor.
- Take safety measures, e.g. provide covers, to prevent accidental access to the rotating parts of the servo motor during operation.
- Never hit the servo motor or shaft, especially when coupling the servo motor to the machine. Otherwise, the encoder may malfunction.
- Do not subject the servo motor shaft to more than the permissible load. Otherwise, the shaft may break.

### (2) Wiring

## ⚠ CAUTION

- Wire the equipment correctly and securely. Otherwise, the servo motor may operate unexpectedly.
- Do not install a power capacitor, surge killer or radio noise filter (FR-BIF-(H) option) between the servo amplifier (drive unit) and servo motor.
- Connect the wires to the correct phase terminals (U, V, W) of the servo amplifier (drive unit) and servo motor. Otherwise, the servo motor does not operate properly.
- Connect the servo motor power terminal (U, V, W) to the servo motor power input terminal (U, V, W) directly. Do not let a magnetic contactor, etc. intervene.

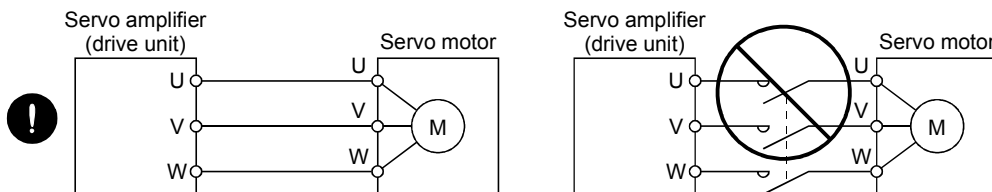

## ⚠ CAUTION

- Do not connect AC power directly to the servo motor. Otherwise, it may cause a malfunction.
- The surge absorbing diode installed to the DC relay for control output should be fitted in the specified direction. Otherwise, the emergency stop and other protective circuits may not operate.

(The following figure shows the case of the MR-J3-□A servo amplifier.)

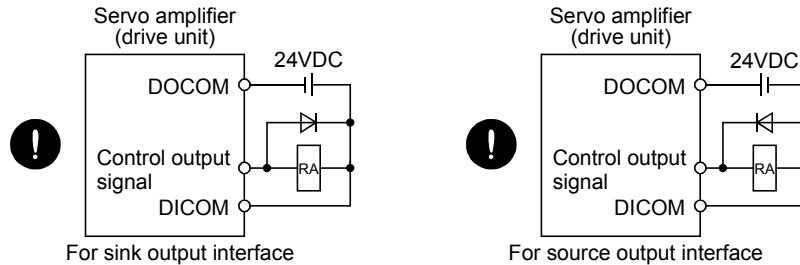

- When the cable is not tightened enough to the terminal block (connector) of the converter unit and servo amplifier, the cable or terminal block (connector) may generate heat because of the poor contact. Be sure to tighten the cable with specified torque.

### (3) Test run adjustment

## ⚠ CAUTION

- Before operation, check the parameter settings. Improper settings may cause some machines to perform unexpected operation.
- The parameter settings must not be changed excessively. Operation will be instable.

### (4) Usage

## ⚠ CAUTION

- Provide an external emergency stop circuit to ensure that operation can be stopped and power switched off immediately.
- Do not scratch the coated surface with hard objects nor clean the coated surface with an organic solvent. Doing so may scuff the surface.
- Any person who is involved in disassembly and repair should be fully competent to do the work.
- Before resetting an alarm, make sure that the run signal into the converter unit and servo amplifier (drive unit) is off to prevent an accident. A sudden restart is made if an alarm is reset with the run signal on.
- Do not modify the equipment.
- Use a noise filter, etc. to minimize the influence of electromagnetic interference. Electromagnetic interference may be given to electronic equipment used near the converter unit and servo amplifier (drive unit).
- Burning or breaking a converter unit and servo amplifier (drive unit) may cause a toxic gas. Do not burn or break a converter unit and servo amplifier (drive unit).
- Use the converter unit and servo amplifier (drive unit) with the specified servo motor.
- The electromagnetic brake on the servo motor is designed to hold the servo motor shaft and should not be used for ordinary braking.
- For such reasons as service life and mechanical structure (e.g. where a ball screw and the servo motor are coupled via a timing belt), the electromagnetic brake may not hold the servo motor shaft. To ensure safety, install a stopper on the machine side.

## (5) Corrective actions

### ⚠ CAUTION

- When it is assumed that a hazardous condition may take place at the occur due to a power failure or a product fault, use a servo motor with an electromagnetic brake or an external brake mechanism for the purpose of prevention.
- Configure a circuit so that the electromagnetic brake activates with the external emergency stop switch at the same time.

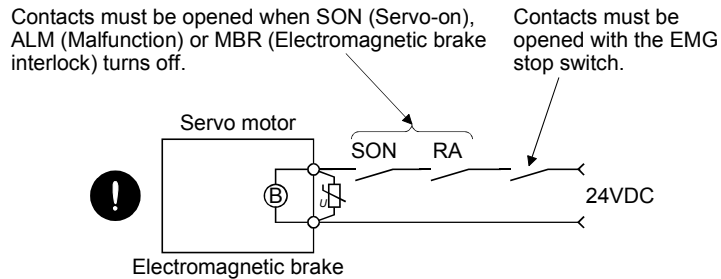

- When any alarm has occurred, eliminate its cause, ensure safety, and deactivate the alarm before restarting operation.
- Provide an adequate protection to prevent unexpected restart after an instantaneous power failure.

## (6) Maintenance, inspection and parts replacement

### ⚠ CAUTION

- With age, the electrolytic capacitor of the converter unit and servo amplifier (drive unit) will deteriorate. To prevent a secondary accident due to a fault, it is recommended to replace the electrolytic capacitor every 10 years when used in general environment.  
Please contact your local sales office.

## (7) Storage

### ⚠ CAUTION

Note the following points when storing the servo motor for an extended period of time (guideline: three or more months).

- Always store the servo motor indoors in a clean and dry place.
- If it is stored in a dusty or damp place, make adequate provision, e.g. cover the whole product.
- If the insulation resistance of the winding decreases, reexamine the storage method.
- Though the servo motor is rust-proofed before shipment using paint or rust prevention oil, rust may be produced depending on the storage conditions or storage period.  
If the servo motor is to be stored for longer than six months, apply rust prevention oil again especially to the machined surfaces of the shaft, etc.
- Before using the product after storage for an extended period of time, hand-turn the servo motor output shaft to confirm that nothing is wrong with the servo motor. (When the servo motor is equipped with a brake, make the above check after releasing the brake with the brake power supply.)
- When the equipment has been stored for an extended period of time, consult your local sales office.

## (8) General instruction

### CAUTION

- To illustrate details, the equipment in the diagrams of this Instruction Manual may have been drawn without covers and safety guards. When the equipment is operated, the covers and safety guards must be installed as specified. Operation must be performed in accordance with this Instruction Manual.

## ● DISPOSAL OF WASTE ●

Please dispose a converter unit, servo amplifier (drive unit), battery (primary battery) and other options according to your local laws and regulations.

### FOR MAXIMUM SAFETY

- These products have been manufactured as a general-purpose part for general industries, and have not been designed or manufactured to be incorporated in a device or system used in purposes related to human life.
- Before using the products for special purposes such as nuclear power, electric power, aerospace, medicine, passenger movement vehicles or underwater relays, contact your local sales office.
- These products have been manufactured under strict quality control. However, when installing the product where major accidents or losses could occur if the product fails, install appropriate backup or failsafe functions in the system.

## PRECAUTIONS FOR CHOOSING THE PRODUCTS

Mitsubishi will not be held liable for damage caused by factors found not to be the cause of Mitsubishi; machine damage or lost profits caused by faults in the Mitsubishi products; damage, secondary damage, accident compensation caused by special factors unpredictable by Mitsubishi; damages to products other than Mitsubishi products; and to other duties.

## COMPLIANCE WITH CE MARKING

---

Refer to Appendix 2 for the compliance with CE marking.

## CONFORMANCE WITH UL/cUL STANDARD (Under application)

---

Refer to Appendix 3 for the compliance with UL/cUL standard.





## CONTENTS

<b>1. INTRODUCTION</b>	<b>1 - 1 to 1 - 8</b>
1.1 Features of servo motor .....	1 - 1
1.2 Rating plate .....	1 - 3
1.3 Parts identification .....	1 - 4
1.4 Electromagnetic brake .....	1 - 5
1.5 Servo motor shaft shapes .....	1 - 7
<b>2. INSTALLATION</b>	<b>2 - 1 to 2 - 6</b>
2.1 Installation orientation .....	2 - 2
2.2 Cooling fan .....	2 - 2
2.3 Load remove precautions .....	2 - 3
2.4 Permissible load for the shaft .....	2 - 4
2.5 Protection from oil and water .....	2 - 4
2.6 Cable .....	2 - 5
2.7 Servo motor with oil seal .....	2 - 5
2.8 Inspection .....	2 - 5
2.9 Life .....	2 - 6
2.10 Machine accuracies .....	2 - 6
<b>3. CONNECTORS USED FOR SERVO MOTOR WIRING</b>	<b>3 - 1 to 3 - 14</b>
3.1 Selection of connectors .....	3 - 1
3.2 Wiring connectors (Connector configurations A • B • C) .....	3 - 5
3.3 Wiring connectors (Connector configurations D • E • F • G • H) .....	3 - 6
3.4 Wiring connectors (Connector configurations J • K • L • M • N) .....	3 - 12
3.5 Wiring connectors (Connector configurations P • Q) .....	3 - 14
<b>4. CONNECTOR OUTLINE DRAWINGS</b>	<b>4 - 1 to 4 - 8</b>
<b>5. CALCULATION METHODS FOR DESIGNING</b>	<b>5 - 1 to 5 - 16</b>
5.1 Specification symbol list .....	5 - 1
5.2 Position resolution and electronic gear setting .....	5 - 2
5.3 Speed and command pulse frequency .....	5 - 3
5.4 Stopping characteristics .....	5 - 4
5.5 Capacity selection .....	5 - 5
5.6 Load torque equations .....	5 - 8
5.7 Load inertia moment equations .....	5 - 9
5.8 Precautions for home position return .....	5 - 10
5.9 Selection example .....	5 - 11
5.10 Coasting distance of electromagnetic brake .....	5 - 15
5.11 Expression for calculating the electromagnetic brake workload .....	5 - 15

<b>6. HF-MP SERIES • HF-KP SERIES</b>	<b>6 - 1 to 6 -70</b>
---------------------------------------	-----------------------

6.1 Model name make up .....	6 - 1
6.2 Standard specifications .....	6 - 2
6.2.1 Standard specifications list .....	6 - 2
6.2.2 Torque characteristics .....	6 - 4
6.3 Electromagnetic brake .....	6 - 5
6.4 Servo motors with special shafts .....	6 - 6
6.4.1 Keyway shaft (with key) .....	6 - 6
6.4.2 D cut shaft.....	6 - 6
6.5 Servo motors with a reduction gear.....	6 - 7
6.5.1 For general industrial machines compliant (G1) .....	6 - 7
6.5.2 For precision applications compliant (G5/G7).....	6 - 9
6.6 Wiring option .....	6 -11
6.7 Connector installation .....	6 -12
6.8 Outline dimension drawings .....	6 -13
6.8.1 Standard (without an electromagnetic brake, without a reduction gear).....	6 -13
6.8.2 With an electromagnetic brake .....	6 -16
6.8.3 For general industrial machine with a reduction gear (without an electromagnetic brake) .....	6 -21
6.8.4 For general industrial machine with a reduction gear (with an electromagnetic brake) .....	6 -27
6.8.5 For precision application with flange mounting, flange output type reduction gear (without an electromagnetic brake) .....	6 -34
6.8.6 For precision application with flange mounting, flange output type reduction gear (with an electromagnetic brake) .....	6 -43
6.8.7 For precision application with flange mounting, shaft output type reduction gear (without an electromagnetic brake) .....	6 -53
6.8.8 For precision application with flange mounting, shaft output type reduction gear (with an electromagnetic brake) .....	6 -61

<b>7. HF-SP SERIES</b>	<b>7 - 1 to 7 -92</b>
------------------------	-----------------------

7.1 Model name make up .....	7 - 1
7.2 Standard specifications .....	7 - 2
7.2.1 Standard specifications list .....	7 - 2
7.2.2 Torque characteristics .....	7 - 6
7.3 Electromagnetic brake .....	7 - 8
7.4 Servo motors with special shafts .....	7 - 9
7.5 Servo motor with oil seal.....	7 - 9
7.6 Servo motors with a reduction gear.....	7 -10
7.6.1 For general industrial machines compliant (G1/G1H).....	7 -10
7.6.2 For precision application compliant (G5/G7).....	7 -14
7.7 Wiring option .....	7 -16
7.8 Outline dimension drawings .....	7 -17
7.8.1 Standard (without an electromagnetic brake, without a reduction gear).....	7 -17
7.8.2 With an electromagnetic brake .....	7 -20
7.8.3 For general industrial machine with a reduction gear (without an electromagnetic brake) .....	7 -24
7.8.4 For general industrial machine with a reduction gear (with an electromagnetic brake) .....	7 -34
7.8.5 For general industrial machine with a reduction gear (leg type · without an electromagnetic brake).....	7 -44

7.8.6 For general industrial machine with a reduction gear (leg type · with an electromagnetic brake) .....	7 -54
7.8.7 Flange-mounting flange output type for precision application compliant (without an electromagnetic brake) .....	7 -64
7.8.8 Flange-mounting flange output type for precision application compliant (with an electromagnetic brake) .....	7 -71
7.8.9 Flange-mounting shaft output type for precision application compliant (without an electromagnetic brake) .....	7 -78
7.8.10 Flange-mounting shaft output type for precision application compliant (with an electromagnetic brake) .....	7 -85

<b>8. HA-LP SERIES</b>	<b>8 - 1 to 8 -24</b>
------------------------	-----------------------

8.1 Model name make up .....	8 - 1
8.2 Standard specifications .....	8 - 2
8.2.1 Standard specifications list .....	8 - 2
8.2.2 Torque characteristics .....	8 - 9
8.3 Electromagnetic brake .....	8 -12
8.4 Servo motors with special shafts .....	8 -13
8.5 Wiring option .....	8 -14
8.6 Cooling fan .....	8 -14
8.7 Outline dimension drawings .....	8 -15
8.7.1 Terminal box detail diagram .....	8 -15
8.7.2 Standard (without an electromagnetic brake) .....	8 -17
8.7.3 With an electromagnetic brake .....	8 -23
8.8 Servo motor with oil seal .....	8 -24

<b>9. HC-RP SERIES</b>	<b>9 - 1 to 9 -42</b>
------------------------	-----------------------

9.1 Model name make up .....	9 - 1
9.2 Standard specifications .....	9 - 2
9.2.1 Standard specifications list .....	9 - 2
9.2.2 Torque characteristics .....	9 - 4
9.3 Electromagnetic brake .....	9 - 5
9.4 Servo motors with special shafts .....	9 - 6
9.5 Servo motors with a reduction gear for precision application compliant (G5/G7) .....	9 - 7
9.6 Wiring option .....	9 - 9
9.7 Outline dimension drawings .....	9 -10
9.7.1 Standard (without an electromagnetic brake) .....	9 -10
9.7.2 With an electromagnetic brake .....	9 -12
9.7.3 Flange-mounting flange output type for precision application compliant (without an electromagnetic brake) .....	9 -15
9.7.4 Flange-mounting flange output type for precision application compliant (with an electromagnetic brake) .....	9 -21
9.7.5 Flange-mounting shaft output type for precision application compliant (without an electromagnetic brake) .....	9 -28
9.7.6 Flange-mounting shaft output type for precision application compliant (with an electromagnetic brake) .....	9 -34
9.8 Servo motor with oil seal .....	9 -41

<b>10. HC-UP SERIES</b>	<b>10 - 1 to 10 -12</b>
-------------------------	-------------------------

10.1 Model name make up .....	10 - 1
10.2 Standard specifications.....	10 - 2
10.2.1 Standard specifications list .....	10 - 2
10.2.2 Torque characteristics.....	10 - 4
10.3 Electromagnetic brake .....	10 - 5
10.4 Servo motors with special shafts.....	10 - 6
10.5 Wiring option .....	10 - 6
10.6 Outline dimension drawings .....	10 - 7
10.6.1 Standard (without an electromagnetic brake) .....	10 - 7
10.6.2 With an electromagnetic brake .....	10 - 9
10.7 Servo motor with oil seal.....	10 -12

<b>11. HC-LP SERIES</b>	<b>11 - 1 to 11 -12</b>
-------------------------	-------------------------

11.1 Model name make up .....	11 - 1
11.2 Standard specifications.....	11 - 2
11.2.1 Standard specifications list .....	11 - 2
11.2.2 Torque characteristics.....	11 - 4
11.3 Electromagnetic brake .....	11 - 5
11.4 Servo motors with special shafts.....	11 - 6
11.5 Wiring option .....	11 - 6
11.6 Outline dimension drawings .....	11 - 7
11.6.1 Standard (without an electromagnetic brake) .....	11 - 7
11.6.2 With an electromagnetic brake .....	11 - 9
11.7 Servo motor with oil seal.....	11 -12

<b>12. HF-JP SERIES</b>	<b>12 - 1 to 12 -28</b>
-------------------------	-------------------------

12.1 Model name make up .....	12 - 1
12.2 Standard specifications.....	12 - 2
12.2.1 Standard specifications list .....	12 - 2
12.2.2 Torque characteristics.....	12 - 6
12.3 Electromagnetic brake .....	12 - 8
12.4 Servo motors with special shafts.....	12 - 9
12.5 Wiring option .....	12 - 9
12.6 Outline dimension drawings .....	12 -10
12.6.1 Standard (without an electromagnetic brake) .....	12 -10
12.6.2 With an electromagnetic brake .....	12 -19
12.7 Servo motor with oil seal.....	12 -28

<b>13. HG-AK SERIES</b>	<b>13 - 1 to 13 -10</b>
-------------------------	-------------------------

13.1 Model name make up .....	13 - 1
13.2 Standard specifications.....	13 - 2
13.2.1 Standard specifications list .....	13 - 2
13.2.2 Torque characteristics.....	13 - 4
13.3 Electromagnetic brake characteristics .....	13 - 5
13.4 Servo motors with special shafts.....	13 - 6

13.5 Wiring option ..... 13 - 6

13.6 Dimensions..... 13 - 6

    13.6.1 Standard (without an electromagnetic brake) ..... 13 - 7

    13.6.2 With an electromagnetic brake ..... 13 - 8

APPENDIX	App.- 1 to App.- 4
----------	--------------------

App. 1 Servo motor ID codes.....App.- 1

App. 2 Compliance with the CE marking.....App.- 3

App. 3 Conformance with UL/cUL standard.....App.- 4



# 1. INTRODUCTION

## 1. INTRODUCTION

### 1.1 Features of servo motor

The following table indicates the main features of the servo motor. The items marked ○ are supported as standard. For detailed specifications, refer to the chapter of the servo motor series.

Item		Servo motor series			
		HF-MP	HF-KP	HF-SP	HA-LP
Feature		Ultra-Low inertia/Small capacity	Low inertia/Small capacity	Medium inertia/medium capacity	Low inertia/Middle large capacity
Rated speed	1000r/min			○	○
	1500r/min				○
	2000r/min			○	○
	3000r/min	○	○		
Encoder resolution [pulse/rev]		262144	262144	262144	262144
Rated output [kW]		0.05 to 0.75	0.05 to 0.75	0.5 to 7.0	5.0 to 55.0
Power supply voltage of compatible servo amplifier (Note 1)	One-phase 200 to 230VAC	○	○	○ (Note 5)	
	Three-phase 200 to 230VAC	○	○	○	○
	Three-phase 380 to 480VAC			○	○
	One-phase 100 to 120VAC	(Note 2)	(Note 2)		
Electromagnetic Brake		(Note 2)	(Note 2)	(Note 2)	(Note 2)
Special shaft		(Note 2)	(Note 2)	(Note 2)	(Note 2)
Reduction Gear		(Note 2)	(Note 2)	(Note 2)	
Absolute Encoder		○	○	○	○
Compliance with Overseas Standards	EN Standard	○	○	○ (Note 6)	○ (Note 9)
	UL/cUL Standard	○	○	○	○
IP rating		IP65 (Note 3 * 4)	IP65 (Note 3 * 4)	IP67 (Note 3)	IP44 (Note 3)
Interchangeable servo motor		HC-KFS HC-MFS HC-KF HC-MF	HC-KFS HC-MFS HC-KF HC-MF	HC-SFS HC-SF HA-SH HA-SE	HA-LFS * HA-LH HA-LF



# 1. INTRODUCTION

Item		Servo motor series				
		HC-RP	HC-UP	HC-LP	HF-JP	HG-AK
Feature		Low inertia/Middle capacity	Flat type/Middle capacity	Low inertia/Middle capacity	Low inertia/Middle capacity	Compact size/Small capacity
Rated speed	2000r/min		○	○		
	3000r/min	○			○	○
Encoder resolution [pulse/rev]		262144	262144	262144	262144	262144
Rated output [kW]		1.0 to 5.0	0.75 to 5.0	0.5 to 3.0	0.5 to 15.0	0.01 to 0.03
Power supply voltage of compatible servo amplifier (Note 1)	One-phase 200 to 230VAC		○ (Note 7)	○ (Note 8)		
	Three-phase 200 to 230VAC	○	○	○	○	
	Three-phase 380 to 480VAC				○	
	One-phase 100 to 120VAC					
	48VDC/24VDC					○
Electromagnetic Brake		(Note 2)	(Note 2)	(Note 2)	(Note 2)	(Note 2)
Special shaft		(Note 2)	(Note 2)	(Note 2)	(Note 2)	(Note 2)
Reduction Gear		(Note 2)				
Absolute Encoder		○	○	○	○	○
Compliance with Overseas Standards	EN Standard	○	○	○	○	○
	UL/cUL Standard	○	○	○	○	○
IP rating		IP65 (Note 3)	IP65 (Note 3)	IP65 (Note 3)	IP67 (Note 3)	IP55 (Note 10)
Interchangeable servo motor		HC-RFS · HC-RF	HC-UFS · HC-UF	HC-LFS		

Note 1. Some power supply voltages may not be usable depending on the servo amplifier (for the HA-LP servo motor of 30kW or more, converter unit and drive unit) capacity.

For the power supply voltage range, refer to the Servo Amplifier Instruction Manual.

2. Compatible products are available. For details, refer to the chapter of the servo motor series.

3. Except for the shaft-through portion.

4. Except for the connector.

5. Only HF-SP51, 52 corresponds.

6. HF-SP301, 421, and 524 to 7024 will be supported.

7. Only HC-UP72 corresponds.

8. Only HC-LP52 corresponds.

9. The following models will be supported: HA-LP25K1 to 37K1, 30K1M, 37K1M, 30K2 and 37K2.

10. Except for the shaft-through, connector, and power cable outlet portion.

# 1. INTRODUCTION

## 1.2 Rating plate

(1) HF-MP series/HF-KP series/HF-SP series/HA-LP series/HC-RP series/HC-UP series/HC-LP series/HF-JP series servo motor

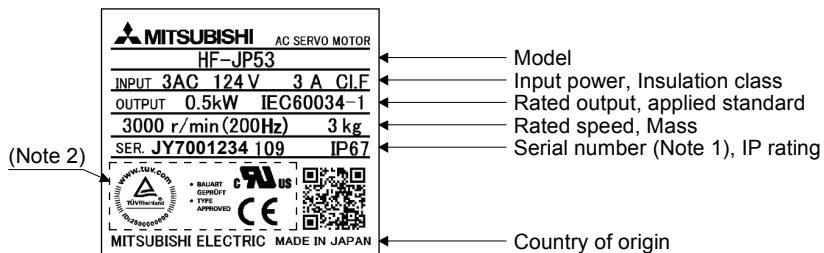

Note 1. Production year and month of the servo motor are indicated in a serial number on the rating plate. The year and month are indicated by the last two digits of the year and one digit of the month [1 to 9, X(10), Y(11), and Z(12)]. For January 2012, the Serial No. is like, "SER. □□□□□□□□121".

2. Products, which are certificated applications to standards by certification bodies, display approval marks. The design of the marks depends on its certification body.

(2) HG-AK series servo motor

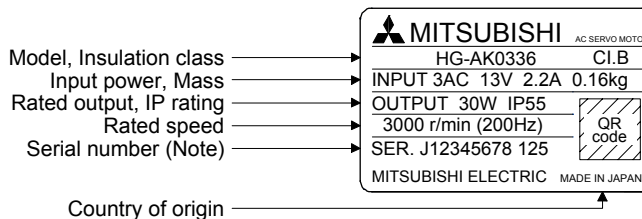

Note. Production year and month of the servo motor are indicated in a serial number on the rating plate. The year and month are indicated by the last two digits of the year and one digit of the month [1 to 9, X(10), Y(11), and Z(12)]. For January 2012, the Serial No. is like, "SER. □□□□□□□□121".

# 1. INTRODUCTION

## 1.3 Parts identification

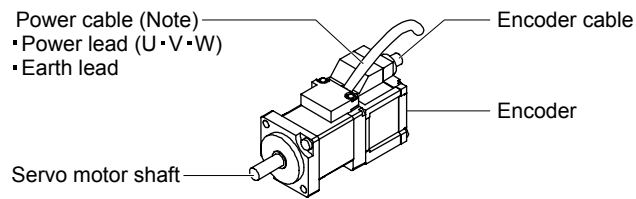

Note. The servo motor with an electromagnetic brake has an electromagnetic brake lead.

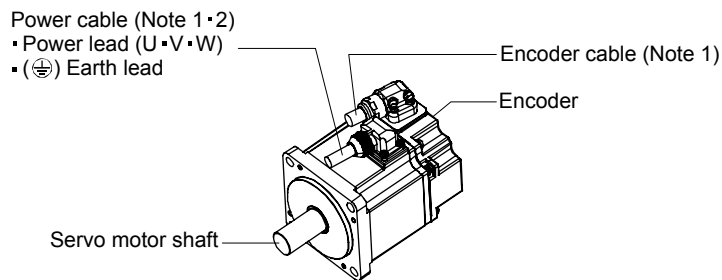

Note 1. The encoder cable and power supply cable are options.

2. An electromagnetic brake cable is separately required for the servo motor with an electromagnetic brake.

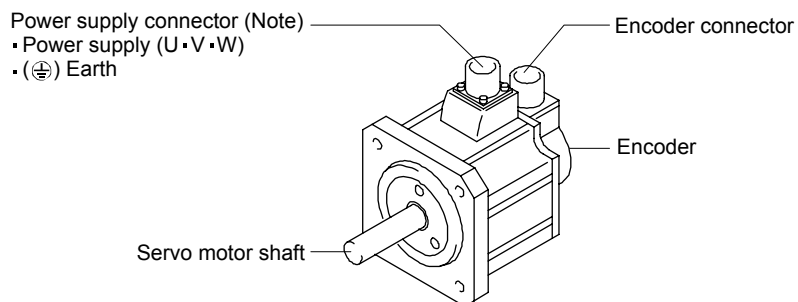

Note. The servo motor with an electromagnetic brake has the electromagnetic brake connector separately.

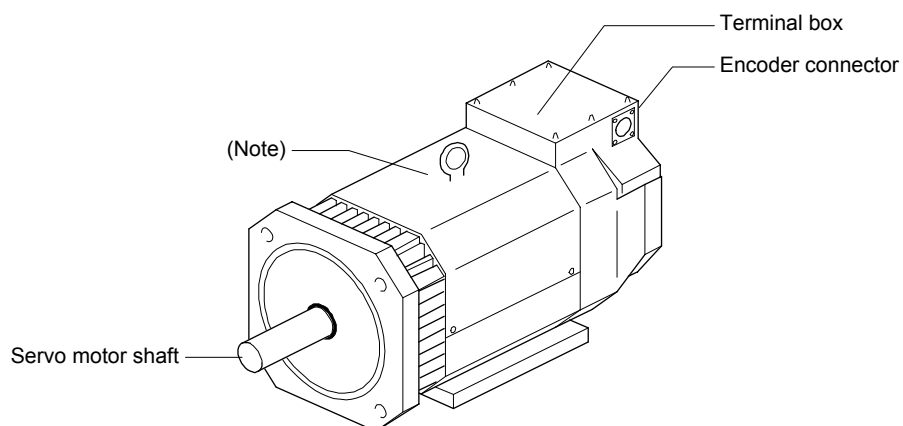

Note. The servo motor with an electromagnetic brake has the electromagnetic brake connector separately.

# 1. INTRODUCTION

## 1.4 Electromagnetic brake



### CAUTION

- The electromagnetic brake is provided to prevent a drop at a power failure or servo alarm occurrence during vertical drive or to hold a shaft at a stop. Do not use it for normal braking (including braking at servo lock).
- The electromagnetic brake has a time lag. Use the electromagnetic brake so that servo motor control starts after the electromagnetic brake has completely opened. Be sure to check the time lag of the braking with a real machine.
- Configure an electromagnetic brake circuit so that it is activated also by an external EMG stop switch.
- For details of the circuit configuration and timing chart, refer to the Servo Amplifier Instruction Manual.
- While the electromagnetic brake is opened, the motor may be raised to high temperature regardless of driving.
- The life will be shortened under sudden acceleration/deceleration conditions.

The servo motor with an electromagnetic brake can be used to prevent a drop in vertical lift applications or to ensure double safety at an emergency stop, for example. When performing servo motor operation, supply power to the electromagnetic brake to release the brake. Switching power off makes the brake effective.

### (1) Electromagnetic brake power supply

Prepare the following power supply for use with the electromagnetic brake only. The electromagnetic brake terminals (B1, B2) have no polarity.

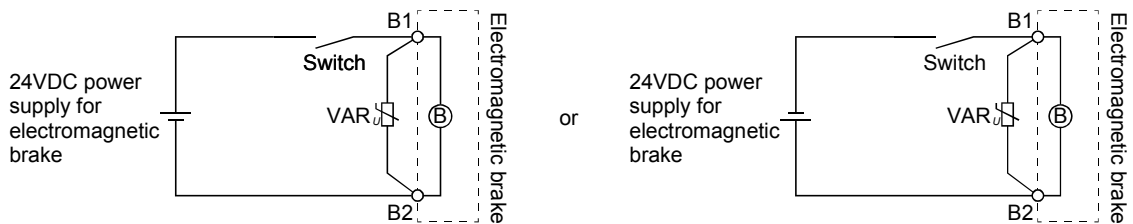

The surge absorber (VAR) must be installed across B1-B2. For the selection and selection example of the surge absorber, refer to "Electromagnetic brake characteristic" in the chapter of each servo motor series. When you use a diode for a surge absorber, the electromagnetic braking time will be longer.

### (2) Sound generation

Though the brake lining may rattle during operation, it poses no functional problem.

If braking sound occurs, it may be improved by setting the machine resonance suppression filter or adaptive vibration suppression control in the servo amplifier (drive unit) parameters. For details, refer to the servo amplifier instruction manual.

### (3) Selection of surge absorbers for electromagnetic brake circuit

The following shows an example how to select a varistor with a surge absorber.

#### (a) Selection conditions

Item	Conditions
Electromagnetic brake specification	R[Ω]: Resistance L[H]: Inductance Vb[V]: Power supply voltage
Desired suppression voltage	Vs[V] or less
Durable surge application time	N times

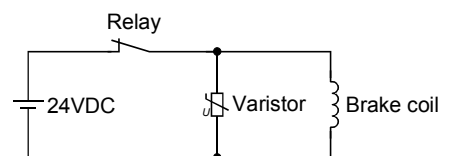

## 1. INTRODUCTION

---

(b) Tentative selection and verification of surge absorber

1) Maximum allowable circuit voltage of varistor

Tentatively select a varistor whose maximum allowable voltage is larger than  $V_b$  [V].

2) Brake current ( $I_b$ )

$$I_b = \frac{V_b}{R} \text{ [A]}$$

3) Energy ( $E$ ) generated by brake coil

$$E = \frac{L \times I_b^2}{2} \text{ [J]}$$

4) Varistor limit voltage ( $V_i$ )

From the energy ( $E$ ) generated in the brake coil and the varistor characteristic diagram, calculate the varistor limit voltage ( $V_i$ ) when the brake current ( $I_b$ ) flows into the tentatively selected varistor during opening of the circuit.

$V_i$  is favorable when the varistor limit voltage ( $V_i$ ) [V] is smaller than the desired suppressed voltage ( $V_s$ ) [V].

If  $V_i$  is not smaller than  $V_s$ , reselect a varistor or improve the withstand voltage of devices.

5) Surge current width ( $\tau$ )

Given that the varistor absorbs all energies, the surge current width ( $\tau$ ) is as follows.

$$\tau = \frac{E}{V_i \times I_b} \text{ [s]}$$

6) Inspection of surge life of varistor

From the varistor characteristic diagram, the guaranteed current value ( $I_p$ ) in which the number of the surge application life is  $N$  at the surge current width ( $\tau$ ).

Calculate the guaranteed current value ( $I_p$ ) to the brake current ( $I_b$ ) ratio ( $I_p/I_b$ ).

If an enough margin is ensured for  $I_p/I_b$ , the number of the surge application life  $N$  [Time] can be considered as favorable.

(4) Others

A leakage magnetic flux will occur at the shaft end of the servo motor equipped with an electromagnetic brake. Note that chips, screws and other magnetic substances are attracted.

# 1. INTRODUCTION

## 1.5 Servo motor shaft shapes

In addition to the straight shaft, the keyway shaft and D cut shaft are available as the servo motor shafts. Except HG-AK series servo motors, the key shaft and D cut shaft cannot be used in very frequent start/stop applications. Since we cannot warrant the servo motor against fracture and similar accidents attributable to a loose key, use a friction coupling, etc. when coupling the shaft with a machine.

The shaft shape of the standard servo motor changes depending on the series and capacity. Refer to the chapter of the servo motor series.

The keyway shaft (with single pointed key) applies to only the servo motor with a reduction gear for precision application.

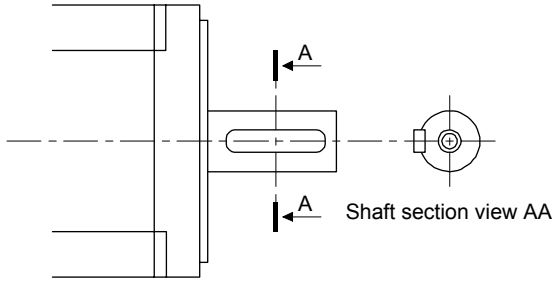

Key shaft (with 2 round end key)

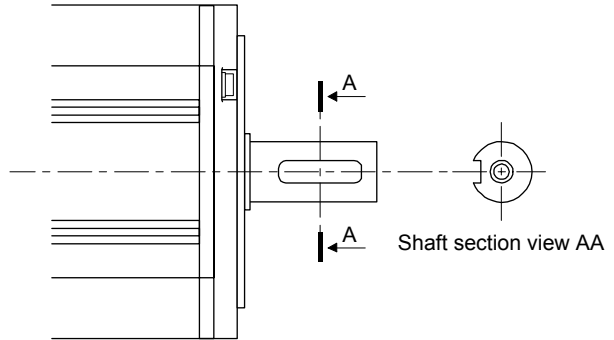

Key shaft (without key)

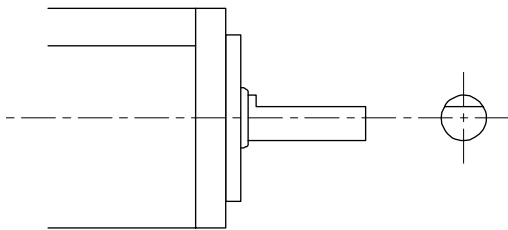

D cut shaft

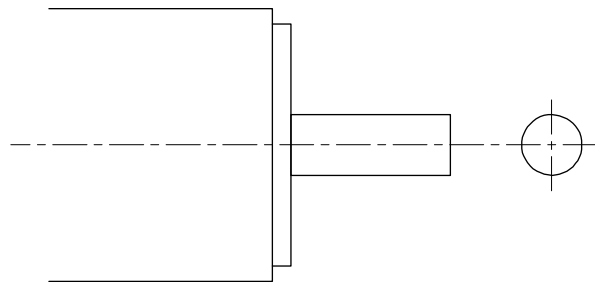

Straight shaft

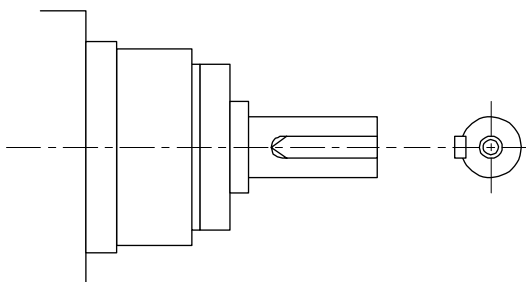

Key shaft (with single pointed key)



## 2. INSTALLATION

---

### 2. INSTALLATION



#### WARNING

- To prevent electric shock, ground each equipment securely.



#### CAUTION

- Stacking in excess of the limited number of products is not allowed.
- Install the equipment to incombustibles. Installing it directly or close to combustibles will led to a fire.
- Install the equipment in a load-bearing place in accordance with this Instruction Manual.
- Do not get on or put heavy load on the equipment to prevent injury.
- Use the equipment within the specified environmental condition range. Refer to the specifications of the servo motor series.
- Do not subject the servo motor to drop impact or shock loads as they are precision equipment.
- Do not hold the cable, shaft or encoder to carry the servo motor. Otherwise, it may cause a malfunction or injury.
- The lifting eyebolts of the servo motor may only be used to transport the servo motor. They must not be used to transport the servo motor when it is mounted on a machine.
- The servo motor with a reduction gear must be installed in the specified direction. Otherwise, it can leak oil, leading to a fire or fault.
- Securely fix the servo motor to the machine. If fixed insecurely, the servo motor will come off during operation, leading to injury.
- Be sure to measure the motor vibration level with the servo motor mounted to the machine when checking the vibration level. A great vibration may cause the early damage of a bearing, encoder, brake, and reduction gear. The great vibration may also cause the poor connector connection or bolt looseness.
- For the gain adjustment at the equipment startup, check the torque waveform and the speed waveform by using a measurement device, and then check that no vibration occurs. If the vibration occurs due to high gain, the vibration may cause the early damage of the servo motor.
- When coupling the shaft end of the servo motor, do not subject the shaft end to impact, such as hammering. The encoder may become faulty.
- When coupling a load to the servo motor, do not use a rigid coupling. Doing so can cause the shaft to break and the bearing to wear out.
- Balance the load to the extent possible. Failure to do so can cause vibration during servo motor operation or damage the bearings and encoder.
- Take safety measures, e.g. provide covers, to prevent accidental access to the rotating parts of the servo motor during operation.
- Do not subject the servo motor shaft to more than the permissible load. Otherwise, the shaft may break, leading to injury.
- When the product has been stored for an extended period of time, contact your local sales office.
- When treating the servo motor, be careful about the edged parts such as the corners of the servo motor.



## 2. INSTALLATION

### 2.1 Installation orientation

#### (1) Standard servo motor

The following table indicates the installation orientation of the standard servo motor.

Servo Motor Series	Direction of Installation	Remarks
HF-MP HC-RP HF-KP HC-UP HF-SP HC-LP HF-JP	May be installed in any direction.	For installation in the horizontal direction, it is recommended to set the connector section downward.
HA-LP(Flange Type) HG-AK		
HA-LP(Flange · leg type)		For installation in the horizontal direction, make the legs face down and use the legs or flange as an installation reference. When using the flange as an installation reference, however, also fix the legs supplementary.

For installation in the horizontal direction, it is recommended to set the connector section downward.  
When installing the servo motor vertically or obliquely, provide a connection and trap for the cable.

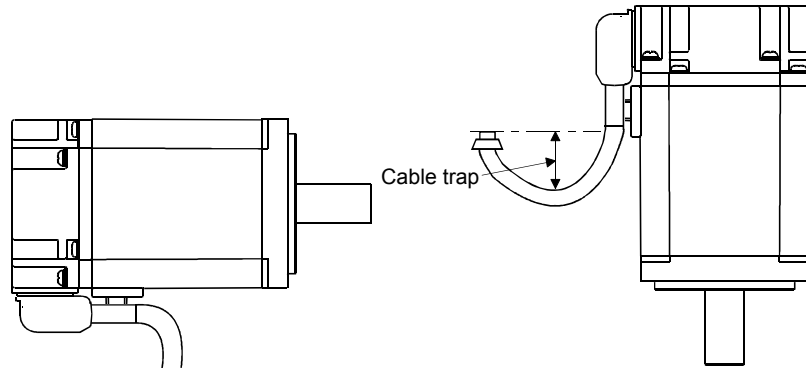

#### (2) Servo motor with an electromagnetic brake

The servo motor with an electromagnetic brake can also be installed in the same orientation as the standard servo motor.

When the servo motor with an electromagnetic brake is installed with the shaft end at top, the brake plate may generate sliding sound but it is not a fault.

#### (3) Servo motor with a reduction gear

The orientation of installing the servo motor with a reduction gear changes depending on the reduction gear type. Be sure to install it in the specified orientation. Refer to the chapter of the servo motor series for details.

### 2.2 Cooling fan

For the servo motor with a cooling fan, ensure to put enough space for the distance L between intake port and wall surface.

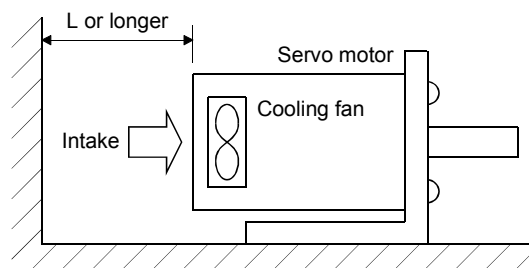

## 2. INSTALLATION

### 2.3 Load remove precautions

• During assembling, the shaft end must not be hammered. Doing so can cause the encoder to fail.

 CAUTION

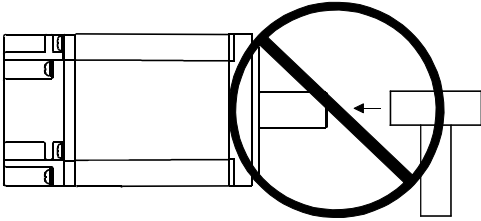

- (1) When mounting a pulley to the servo motor shaft provided with a keyway, use the screw hole in the shaft end. To fit the pulley, first insert a double-end stud into the screw hole of the shaft, put a washer against the end face of the coupling, and insert and tighten a nut to force the pulley in.

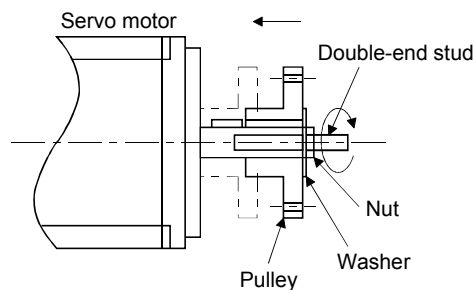

- (2) For the shaft without a keyway, use a friction coupling or the like.
- (3) When removing the pulley, use a pulley remover to protect the shaft from hard load and or impact.
- (4) To ensure safety, fit a protective cover or the like on the rotary area, such as the pulley, mounted to the shaft.
- (5) When a threaded shaft end part is needed to mount a pulley on the shaft, please contact your local sales office.
- (6) The orientation of the encoder on the servo motor cannot be changed.
- (7) For installation of the servo motor, use spring washers, etc. and fully tighten the bolts so that they do not become loose due to vibration.

## 2. INSTALLATION

### 2.4 Permissible load for the shaft



#### CAUTION

- Do not use a rigid coupling as it may apply excessive bending load to the shaft of the servo motor, leading the shaft to break and the bearing to wear out.

For the permissible shaft load specific to the servo motor, refer to the chapter of the servo motor series.

- (1) Use a flexible coupling and make sure that the misalignment of the shaft is less than the permissible radial load.
- (2) When using a pulley, sprocket or timing belt, select a diameter that will fit into the permissible radial load.
- (3) Excess of the permissible load can cause the bearing life to reduce and the shaft to break.
- (4) The load indicated in this section is static load in a single direction and does not include eccentric load. Make eccentric load as small as possible. Not doing so can cause the servo motor to be damaged.

### 2.5 Protection from oil and water

Provide adequate protection to prevent foreign matter, such as oil from entering the servo motor shaft. When installing the servo motor, consider the items in this section.

- (1) Do not use the servo motor with its cable soaked in oil or water.

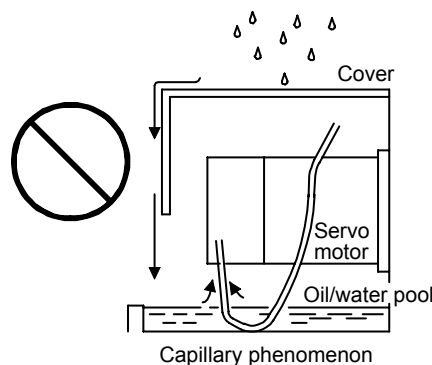

- (2) When the servo motor is to be installed with the shaft end at top, provide measures so that it is not exposed to oil and water entering from the machine side, gear box, etc.

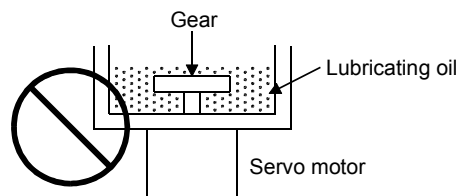

- (3) If the servo motor is exposed to oil such as coolant, the sealant, packing, cable and others may be affected depending on the oil type.
- (4) In the environment where the servo motor is exposed to oil mist, oil, water, grease and/or like, a standard specifications servo motor may not be usable. Please contact your local sales office.

## 2. INSTALLATION

### 2.6 Cable

The power supply and encoder cables routed from the servo motor should be fixed to the servo motor to keep them unmovable. Otherwise, cable breaks may occur. In addition, do not modify the connectors, terminals and others at the ends of the cables.

### 2.7 Servo motor with oil seal

For the servo motor with oil seal, the oil seal prevents the entry of oil into the servo motor. Make sure to install it according in this section. The functions have no problem even if the servo motor with oil seal may sound during operation.

#### (1) Pressure and oil level

Install the servo motor horizontally, and set the oil level in the gear box to be lower than the oil seal lip always. If the oil level is higher than the oil seal lip, the oil that entered into the servo motor may cause any failure.

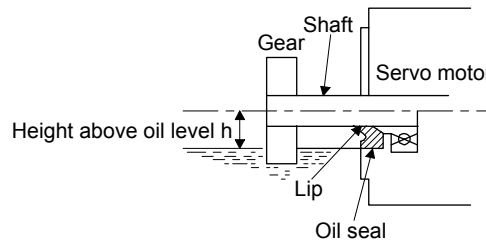

High pressure against the oil seal causes the abrasion and makes the life be short. Keep constant internal pressure by equipping a ventilator to the gear box.

#### (2) Temperature

High temperature against the oil seal lip makes the life be short. Avoid exposing the oil seal lip to high temperature oil since applicable temperature of the material is up to 100°C (212°F) and temperature of the oil seal lip rises within 10 to 15°C (50 to 59°F) at maximum rotation.

### 2.8 Inspection



#### WARNING

- Before starting maintenance and/or inspection, turn off the power and wait for 15 minutes or more (20 minutes or for drive unit 30kW or more) until the charge lamp turns off. Then, confirm that the voltage between P(+) and N(-) (L+ and L- for drive unit 30kW or more) is safe with a voltage tester and others. Otherwise, an electric shock may occur. In addition, always confirm from the front of the servo amplifier (converter unit), whether the charge lamp is off or not.
- To avoid an electric shock, only qualified personnel should attempt inspections. For repair and parts replacement, contact your safes representative.



#### CAUTION

- Do not disassemble and/or repair the equipment on customer side.

It is recommended to make the following checks periodically.

## 2. INSTALLATION

- (a) Check the servo motor bearings, brake section, etc. for unusual noise.
- (b) Check the cables and the like for scratches and cracks. Especially when the junction cable is movable, perform periodic inspection according to operating conditions.
- (c) Check the servo motor shaft and coupling for misalignment.
- (d) Check the power supply connector and encoder connector tightening screws for looseness.

### 2.9 Life

The following parts must be changed periodically as listed below. If any part is found faulty, it must be changed immediately even when it has not yet reached the end of its life, which depends on the operating method and environmental conditions. For parts replacement, please contact your local sales office.

Part name	Guideline of life
Bearings	20,000 to 30,000 hours
Encoder	20,000 to 30,000 hours
Cooling fan	20,000 hours
Oil seal	5,000 hours

#### (a) Bearings

When the servo motor is run at rated speed under rated load, bearings change the bearings in 20,000 to 30,000 hours as a guideline. This differs on the operating conditions. The bearings must also be changed if unusual noise or vibration is found during inspection.

#### (b) Oil seal (including oil seal used on the reduction gear)

Must be changed in 5,000 hours of operation at rated speed as a guideline. These parts must also be changed if oil leakage, etc. is found during inspection.

### 2.10 Machine accuracies

The following table indicates the machine accuracies of the servo motor around the output shaft and mounting. (except the optional products)

Accuracy [mm]	Measuring position	Flange size			
		Less than □100	□130	□176 to □250	280 or more
Runout of flange surface to output shaft	a)	0.05	0.06	0.08	0.08
Runout of fitting OD of flange surface	b)	0.04	0.04	0.06	0.08
Runout of output shaft end	c)	0.02	0.02	0.03	0.03

Reference diagram

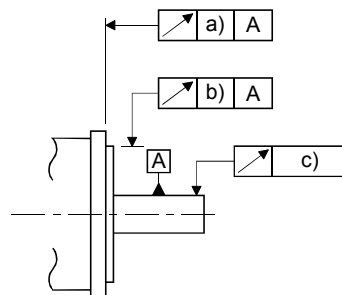

### 3. CONNECTORS USED FOR SERVO MOTOR WIRING

#### 3. CONNECTORS USED FOR SERVO MOTOR WIRING

POINT
<ul style="list-style-type: none"> <li>The IP rating indicated is the connector's protection against ingress of dust and water when the connector is connected to a servo amplifier or servo motor. If the IP rating of the connector, servo amplifier and servo motor vary, the overall IP rating depends on the lowest IP rating of all components.</li> </ul>

##### 3.1 Selection of connectors

Use the connector configuration products given in the table as the connectors for connection with the servo motor. Refer to section 3.2 for the compatible connector configuration products.

##### (1) HF-MP Series • HF-KP Series

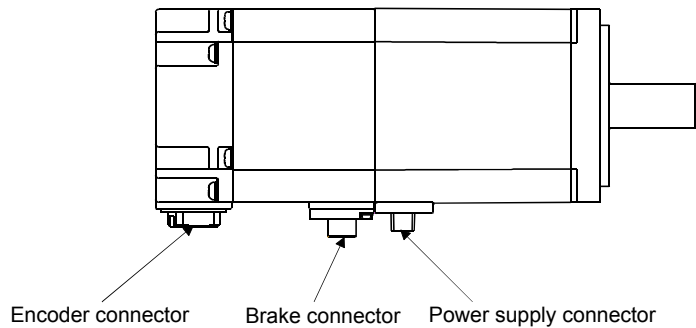

Servo motor	Wiring connector		
	For encoder	For power supply	For brake
HF-MP□	Connector configuration A	Connector configuration B	Connector configuration C
HF-KP□			

##### (2) HF-SP Series

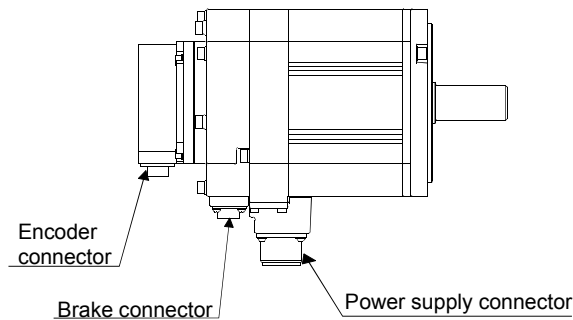

Servo motor	Wiring connector		
	For encoder	For power supply	For brake
HF-SP51 • 81	Connector configuration D	Connector configuration E	Connector configuration F
HF-SP52 to 152			
HF-SP524 to 1524		Connector configuration G	
HF-SP121 to 301			
HF-SP202 to 502			
HF-SP2024 to 5024		Connector configuration H	
HF-SP421			
HF-SP702			
HF-SP7024			

### 3. CONNECTORS USED FOR SERVO MOTOR WIRING

#### (3) HA-LP Series

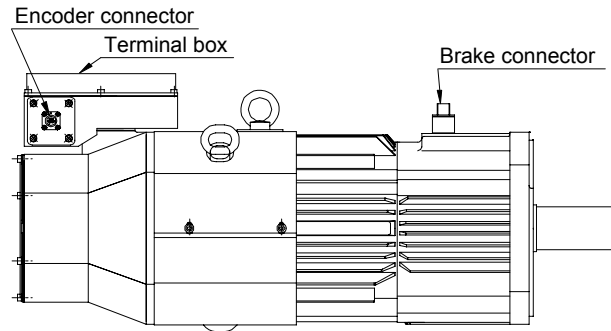

Servo motor	Wiring connector		
	For encoder	For power supply	For brake
HA-LP502	Connector configuration D	Connector configuration K	/
HA-LP702		Connector configuration H	
HA-LP601 to 12K1		None(Terminal box)	Connector configuration J
HA-LP701M to 15K1M			
HA-LP11K2 to 22K2			
HA-LP11K24 to 22K24			
HA-LP15K1 to 37K1			
HA-LP22K1M to 37K1M			
HA-LP30K2 · 37K2			
HA-LP25K14 to 37K14			
HA-LP30K1M4 to 50K1M4			
HA-LP30K24 to 55K24			

#### (4) HC-RP Series

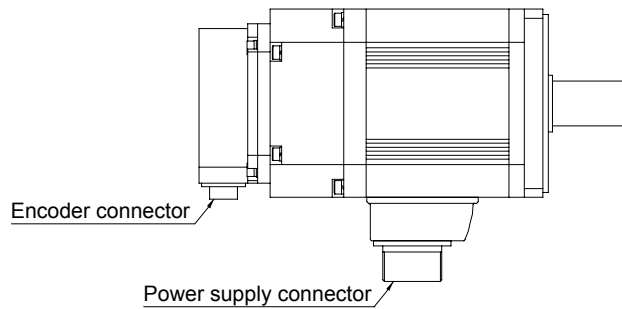

Servo motor	Wiring connector		
	For encoder	For power supply	For brake
HC-RP103 to 203	Connector configuration D	Connector configuration L	Sharing for power supply (Note)
HC-RP353 · 503		Connector configuration K	

Note. Brake connector is not required since the power supply connector has a pin assigned for electromagnetic brake.

### 3. CONNECTORS USED FOR SERVO MOTOR WIRING

#### (5) HC-UP Series

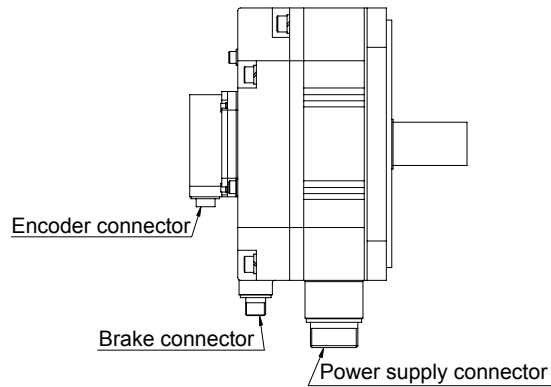

Servo motor	Wiring connector		
	For encoder	For power supply	For brake
HC-UP72 · 152	Connector configuration D	Connector configuration L	Sharing for power supply (Note)
HC-UP202 to 502		Connector configuration K	Connector configuration J

Note. Brake connector is not required since the power supply connector has a pin assigned for electromagnetic brake.

#### (6) HC-LP Series

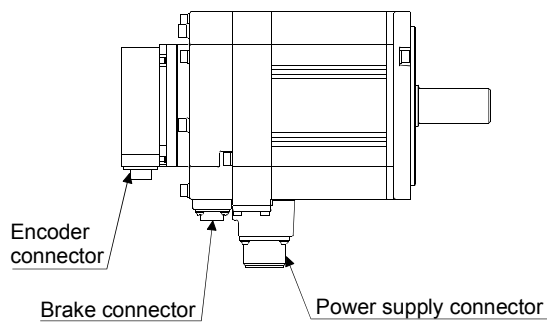

Servo motor	Wiring connector		
	For encoder	For power supply	For brake
HC-LP52 to 152	Connector configuration D	Connector configuration L	Sharing for power supply (Note)
HC-LP202 · 302		Connector configuration K	Connector configuration J

Note. Brake connector is not required since the power supply connector has a pin assigned for electromagnetic brake.



### 3. CONNECTORS USED FOR SERVO MOTOR WIRING

#### (7) HF-JP Series

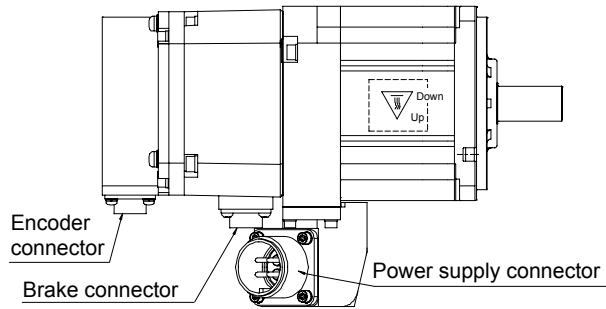

Servo motor	Wiring connector		
	For encoder	For power supply	For brake
HF-JP53 to 203	Connector configuration D	Connector configuration E	Connector configuration F
HF-JP534 to 5034		Connector configuration G	
HF-JP353 · 503		Connector configuration H	
HF-JP703 · 903			
HF-JP7034 · 9034	Connector configuration M, N	Connector configuration J	
HF-JP11K1M · 15K1M			
HF-JP11K1M4 · 15K1M4			

#### (8) HG-AK Series

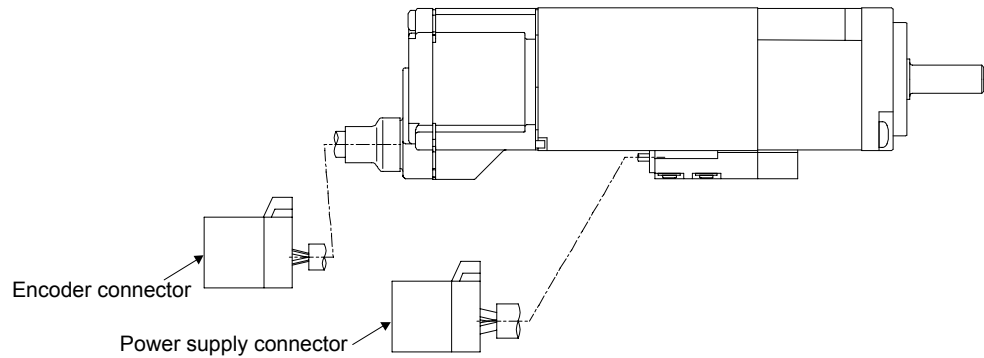

Servo motor	Wiring connector		
	For encoder	For power supply	For brake
HG-AK0136 to 0336	Connector configuration P	Connector configuration Q	Sharing for power supply

### 3. CONNECTORS USED FOR SERVO MOTOR WIRING

#### 3.2 Wiring connectors (Connector configurations A • B • C)

These connectors support EN standards or UL/cUL standards.

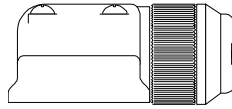

Connector configuration	Feature	Connector	Crimping tool	Servo motor encoder connector
A	IP65	Connector: 2174053-1 (TE Connectivity)	For ground clip: 1596970-1 For REC. contact: 1596847-1 (TE Connectivity)	1674339-1 (TE Connectivity)

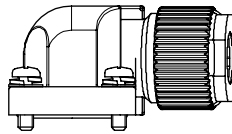

Connector configuration	Feature	Connector	Crimping tool	Servo motor power supply connector
B	IP65	Connector: KN4FT04SJ1-R HOOD/SOCKET INSULATOR/ BUSHING/GROUND NUT Contact: ST-TMH-S-C1B-100 (A534G) (JAE)	CT160-3-TMH5B (JAE)	JN4AT04NJ1 (JAE)

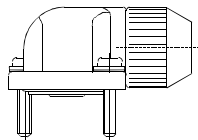

Connector configuration	Feature	Connector	Crimping tool	Servo motor electromagnetic brake connector
C	IP65	Connector: JN4FT02SJ1-R HOOD/SOCKET INSULATOR/ BUSHING/GROUND NUT Contact: ST-TMH-S-C1B-100 (A534G) (JAE)	CT160-3-TMH5B (JAE)	JN4AT02PJ1 (JAE)

### 3. CONNECTORS USED FOR SERVO MOTOR WIRING

#### 3.3 Wiring connectors (Connector configurations D · E · F · G · H)

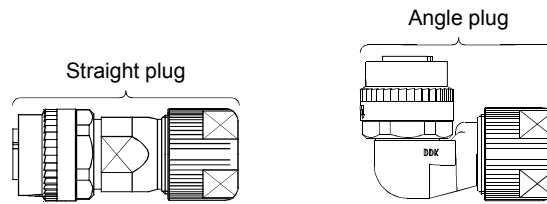

Connector configuration	Feature	Plug (DDK)					Servo motor encoder connector
		Type	Plug	Socket contact	Contact shape	Cable OD [mm]	
D	IP67	Straight	CMV1-SP10S-M1 (one-touch connection type)	CMV1-#22ASC-S1-100	Soldering type Applicable wire size: AWG20 or less	φ5.5 to φ7.5	CM10-R10P
				CMV1-#22ASC-C1-100	Crimping type Applicable wire size: AWG24 to 20 The crimping tool (357J-53162T) is required.		
				CMV1-#22ASC-C2-100	Crimping type Applicable wire size: AWG28 to 24 The crimping tool (357J-53163T) is required.		
			CMV1-SP10S-M2 (one-touch connection type)	CMV1-#22ASC-S1-100	Soldering type Applicable wire size: AWG20 or less	φ7.0 to φ9.0	
				CMV1-#22ASC-C1-100	Crimping type Applicable wire size: AWG24 to 20 The crimping tool (357J-53162T) is required.		
				CMV1-#22ASC-C2-100	Crimping type Applicable wire size: AWG28 to 24 The crimping tool (357J-53163T) is required.		
		CM10-SP10S-VP-M (Note)	CM10-#22SC(S1)(D8)-100	Soldering type Applicable wire size: AWG20 or less	φ6.0 to φ9.0		
			CM10-#22SC(C1)(D8)-100	Crimping type Applicable wire size: AWG22 to 20 Connection tool (357J-50446T) is necessary.			
			CM10-#22SC(C2)(D8)-100	Crimping type Applicable wire size: AWG28 to 23 Connection tool (357J-50447T) is necessary.			

### 3. CONNECTORS USED FOR SERVO MOTOR WIRING

Connector configuration	Feature	Plug (DDK)					Servo motor encoder connector
		Type	Plug	Socket contact	Contact shape	Cable OD [mm]	
D	IP67	Angle	CMV1-AP10S-M1 (one-touch connection type)	CMV1-#22ASC-S1-100	Soldering type Applicable wire size: AWG20 or less	φ5.5 to φ7.5	CM10-R10P
				CMV1-#22ASC-C1-100	Crimping type Applicable wire size: AWG24 to 20 The crimping tool (357J-53162T) is required.		
				CMV1-#22ASC-C2-100	Crimping type Applicable wire size: AWG28 to 24 The crimping tool (357J-53163T) is required.		
			CMV1-AP10S-M2 (one-touch connection type)	CMV1-#22ASC-S1-100	Soldering type Applicable wire size: AWG20 or less	φ7.0 to φ9.0	
				CMV1-#22ASC-C1-100	Crimping type Applicable wire size: AWG24 to 20 The crimping tool (357J-53162T) is required.		
				CMV1-#22ASC-C2-100	Crimping type Applicable wire size: AWG28 to 24 The crimping tool (357J-53163T) is required.		
		CM10-AP10S-VP-M (Note)	CM10-#22SC(S1)(D8)-100	Soldering type Applicable wire size: AWG20 or less	φ6.0 to φ9.0		
			CM10-#22SC(C1)(D8)-100	Crimping type Applicable wire size: AWG22 to 20 Connection tool (357J-50446T) is necessary.			
			CM10-#22SC(C2)(D8)-100	Crimping type Applicable wire size: AWG28 to 23 Connection tool (357J-50447T) is necessary.			

Note. Use this connector if there is a potential risk that a high vibration may be applied to connectors. The connector on the servo motor side can be disconnected up to 5 times. Use dedicated tool 357J-52780T (DDK) or a spanner with a jaw size of 21mm.

### 3. CONNECTORS USED FOR SERVO MOTOR WIRING



Connector configuration	Feature	Plug (DDK)		Cable clamp (DDK)		Servo motor power supply connector
		Type	Model name	Cable OD [mm] (Reference)	Model name	
E	IP67 EN compliant	Straight	CE05-6A18-10SD-D-BSS	$\phi 8.5$ to $\phi 11$	CE3057-10A-2-D	MS3102A18-10P
			Applicable wire size: AWG14 to 12	$\phi 10.5$ to $\phi 14.1$	CE3057-10A-1-D	
		Angle	CE05-8A18-10SD-D-BAS	$\phi 8.5$ to $\phi 11$	CE3057-10A-2-D	
			Applicable wire size: AWG14 to 12	$\phi 10.5$ to $\phi 14.1$	CE3057-10A-1-D	
	(Note) General environment	Straight	D/MS3106B18-10S	$\phi 14.3$	D/MS3057-10A	
			Applicable wire size: AWG14 to 12	(Bushing ID)		
Angle	D/MS3108B18-10S	$\phi 14.3$	D/MS3057-10A			
	Applicable wire size: AWG14 to 12	(Bushing ID)				

Note. Not compliant with the EN.

### 3. CONNECTORS USED FOR SERVO MOTOR WIRING

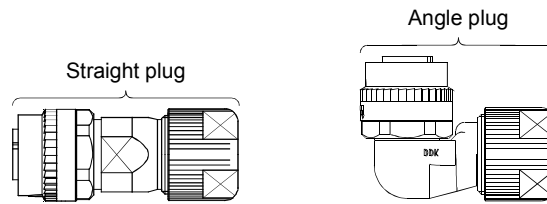

Connector configuration	Feature	Plug (DDK)					Servo motor brake connector
		Type	Straight plug	Socket contact	Contact shape	Cable OD [mm] (Reference)	
F	IP67	Straight	CMV1-SP2S-S (one-touch connection type)	CMV1-#22BSC-S2-100	Soldering type Applicable wire size: AWG16 or less	φ4.0 to φ6.0	CM10-R2P
				CMV1-#22BSC-C3-100	Crimping type Applicable wire size: AWG20 to 16 The crimping tool (357J-53164T) is required.		
			CMV1-SP2S-M1 (one-touch connection type)	CMV1-#22BSC-S2-100	Soldering type Applicable wire size: AWG16 or less	φ5.5 to φ7.5	
				CMV1-#22BSC-C3-100	Crimping type Applicable wire size: AWG20 to 16 The crimping tool (357J-53164T) is required.		
			CMV1-SP2S-M2 (one-touch connection type)	CMV1-#22BSC-S2-100	Soldering type Applicable wire size: AWG16 or less	φ7.0 to φ9.0	
				CMV1-#22BSC-C3-100	Crimping type Applicable wire size: AWG20 to 16 The crimping tool (357J-53164T) is required.		
			CMV1-SP2S-L (one-touch connection type)	CMV1-#22BSC-S2-100	Soldering type Applicable wire size: AWG16 or less	φ9.0 to φ11.6	
				CMV1-#22BSC-C3-100	Crimping type Applicable wire size: AWG20 to 16 The crimping tool (357J-53164T) is required.		
			CM10-SP2S-VP-S (Note)	CM10-#22SC(S2)(D8)-100	Soldering type Applicable wire size: AWG16 or less	φ4.0 to φ6.0	
			CM10-SP2S-VP-M (Note)	CM10-#22SC(S2)(D8)-100		φ6.0 to φ9.0	
			CM10-SP2S-VP-L (Note)	CM10-#22SC(S2)(D8)-100		φ9.0 to φ11.6	
			CM10-SP2S-VP-S (Note)	CM10-#22SC(C3)(D8)-100	Crimping type Applicable wire size: AWG20 to 16 Connection tool (357J-50448T) is necessary.	φ4.0 to φ6.0	
			CM10-SP2S-VP-M (Note)	CM10-#22SC(C3)(D8)-100		φ6.0 to φ9.0	
			CM10-SP2S-VP-L (Note)	CM10-#22SC(C3)(D8)-100		φ9.0 to φ11.6	

### 3. CONNECTORS USED FOR SERVO MOTOR WIRING

Connector configuration	Feature	Plug (DDK)					Servo motor brake connector
		Type	Straight plug	Socket contact	Contact shape	Cable OD [mm] (Reference)	
F	IP67	Angle	CMV1-AP2S-S (one-touch connection type)	CMV1-#22BSC-S2-100	Soldering type Applicable wire size: AWG16 or less	φ4.0 to φ6.0	CM10-R2P
				CMV1-#22BSC-C3-100	Crimping type Applicable wire size: AWG20 to 16 The crimping tool (357J-53164T) is required.		
			CMV1-AP2S-M1 (one-touch connection type)	CMV1-#22BSC-S2-100	Soldering type Applicable wire size: AWG16 or less	φ5.5 to φ7.5	
				CMV1-#22BSC-C3-100	Crimping type Applicable wire size: AWG20 to 16 The crimping tool (357J-53164T) is required.		
			CMV1-AP2S-M2 (one-touch connection type)	CMV1-#22BSC-S2-100	Soldering type Applicable wire size: AWG16 or less	φ7.0 to φ9.0	
				CMV1-#22BSC-C3-100	Crimping type Applicable wire size: AWG20 to 16 The crimping tool (357J-53164T) is required.		
			CMV1-AP2S-L (one-touch connection type)	CMV1-#22BSC-S2-100	Soldering type Applicable wire size: AWG16 or less	φ9.0 to φ11.6	
				CMV1-#22BSC-C3-100	Crimping type Applicable wire size: AWG20 to 16 The crimping tool (357J-53164T) is required.		
			CM10-AP2S-VP-S (Note)	CM10-#22SC(S2)(D8)-100	Soldering type Applicable wire size: AWG16 or less	φ4.0 to φ6.0	
			CM10-AP2S-VP-M (Note)	CM10-#22SC(S2)(D8)-100		φ6.0 to φ9.0	
			CM10-AP2S-VP-L (Note)	CM10-#22SC(S2)(D8)-100		φ9.0 to φ11.6	
			CM10-AP2S-VP-S (Note)	CM10-#22SC(C3)(D8)-100	Crimping type Applicable wire size: AWG20 to 16 Connection tool (357J-50448T) is necessary.	φ4.0 to φ6.0	
			CM10-AP2S-VP-M (Note)	CM10-#22SC(C3)(D8)-100		φ6.0 to φ9.0	
			CM10-AP2S-VP-L (Note)	CM10-#22SC(C3)(D8)-100		φ9.0 to φ11.6	

Note. Use this connector if there is a potential risk that a high vibration may be applied to connectors. The connector on the servo motor side can be disconnected up to 5 times. Use dedicated tool 357J-52780T (DDK) or a spanner with a jaw size of 21mm.

### 3. CONNECTORS USED FOR SERVO MOTOR WIRING



Connector configuration	Feature	Plug (DDK)		Cable clamp (DDK)		Servo motor power supply connector
		Type	Model name	Cable OD [mm] (Reference)	Model name	
G	IP67 EN compliant	Straight	CE05-6A22-22SD-D-BSS Applicable wire size: AWG10 to 8	$\phi 9.5$ to $\phi 13$	CD3057-12A-2-D	MS3102A22-22P
			CE05-8A22-22SD-D-BAS Applicable wire size: AWG10 to 8	$\phi 9.5$ to $\phi 13$	CD3057-12A-1-D	
	(Note) General environment	Angle	D/MS3106B22-22S Applicable wire size: AWG10 to 8	$\phi 12.5$ to $\phi 16$	CD3057-12A-2-D	
			D/MS3108B22-22S Applicable wire size: AWG10 to 8	$\phi 12.5$ to $\phi 16$	CD3057-12A-1-D	

Note. Not compliant with the EN.



Connector configuration	Feature	Plug (DDK)		Backshell	Cable clamp (DDK)		Servo motor power supply connector
		Type	Model name	Model name	Cable OD [mm] (Reference)	Model name	
H	IP67 EN compliant	Straight	(Note 2) CE05-6A32-17SD-D Applicable wire size: AWG4	CE05-32BS-S-D-OB	$\phi 30$ to $\phi 32.5$	CE3057-24A-1-D	CE05-2A32-17PD-B
			CE05-6A32-17SD-D-BSS Applicable wire size: AWG6 to 4		$\phi 27.5$ to $\phi 29.6$	CE3057-24A-2-D	
		Angle	CE05-8A32-17SD-D-BAS Applicable wire size: AWG6 to 4	$\phi 22$ to $\phi 23.8$	CD3057-20A-1-D		
			(Note 1) General environment	Straight	D/MS3106B32-17S Applicable wire size: AWG6 to 4	$\phi 23.8$ or less (Bushing ID)	
	Angle	D/MS3108B32-17S Applicable wire size: AWG6 to 4					

Note 1. Not compliant with the EN.

2. This connector is applicable for the HF-JP15K1M's cable that has an outer diameter more than 23.8mm.



### 3. CONNECTORS USED FOR SERVO MOTOR WIRING

#### 3.4 Wiring connectors (Connector configurations J · K · L · M · N)

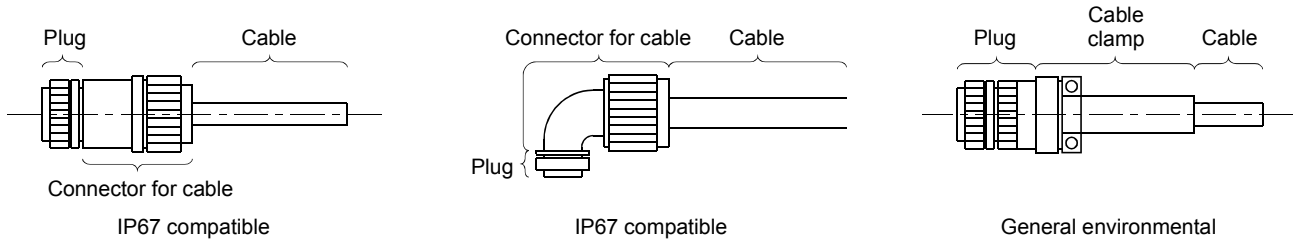

Connector configuration	Feature	Cable side connector					Servo motor brake connector
		Plug (DDK)	Connector for cable				
			Type	Manufacturer	Cable OD [mm] (Reference)	Model name	
J	IP65 EN UL/cUL Standard compliant	D/MS3106A10SL-4S(D190) Applicable wire size: AWG22 to 16	Straight	Nippon Flex	$\phi 4$ to $\phi 8$	ACS-08RL-MS10F	MS3102A10SL-4P
				Daiwa Dengyo	$\phi 5$ to $\phi 8.3$	YSO10-5 to 8	
			Angle	Nippon Flex	$\phi 4$ to $\phi 8$	ACA-08RL-MS10F	
				Daiwa Dengyo	$\phi 8$ to $\phi 12$	ACA-12RL-MS10F	
	(Note) General environment	D/MS3106A10SL-4S Applicable wire size: AWG22 to 16	Straight		$\phi 5.6$ or less (Bushing ID)	D/MS3057-4A	

Note. Not compliant with the EN.

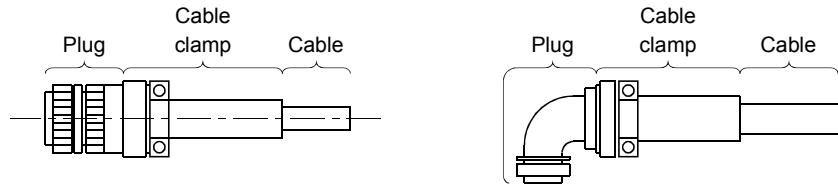

Connector configuration	Feature	Plug (DDK)		Cable clamp (DDK)		Servo motor power supply connector
		Type	Model name	Cable OD [mm] (Reference)	Model name	
K	IP65, EN UL/cUL Standard compliant	Straight	CE05-6A24-10SD-D-BSS	$\phi 13$ to $\phi 15.5$	CE3057-16A-2-D	CE05-2A24-10P
			CE05-8A24-10SD-D-BAS	$\phi 15$ to $\phi 19.1$	CE3057-16A-1-D	
	General environment UL/cUL Standard compliant	Straight	D/MS3106B24-10S	$\phi 13$ to $\phi 15.5$	CE3057-16A-2-D	
			D/MS3108B24-10S	$\phi 15$ to $\phi 19.1$	CE3057-16A-1-D	
		Angle	D/MS3106B24-10S	$\phi 19.1$ (Bushing ID)	D/MS3057-16A	
		Angle	D/MS3108B24-10S			

### 3. CONNECTORS USED FOR SERVO MOTOR WIRING

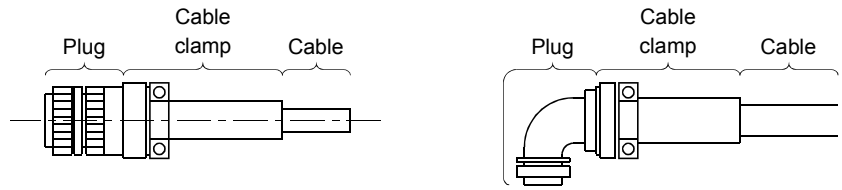

Connector configuration	Feature	Plug (DDK)		Cable clamp (DDK)		Servo motor power supply connector
		Type	Model name	Cable OD [mm] (Reference)	Model name	
L	IP65, EN UL/cUL Standard compliant	Straight	CE05-6A22-23SD-D-BSS	$\phi 9.5$ to $\phi 13$	CE3057-12A-2-D	CE05-2A22-23P
			Applicable wire size: AWG14 to 12	$\phi 12.5$ to $\phi 16$	CE3057-12A-1-D	
	Angle	CE05-8A22-23SD-D-BAS	$\phi 9.5$ to $\phi 13$	CE3057-12A-2-D		
		Applicable wire size: AWG14 to 12	$\phi 12.5$ to $\phi 16$	CE3057-12A-1-D		
General environment UL/cUL Standard compliant	Straight	D/MS3106B22-23S	$\phi 15.9$ (Bushing ID)	D/MS3057-12A		
		Applicable wire size: AWG14 to 12				
		Angle	D/MS3108B22-23S			
			Applicable wire size: AWG14 to 12			

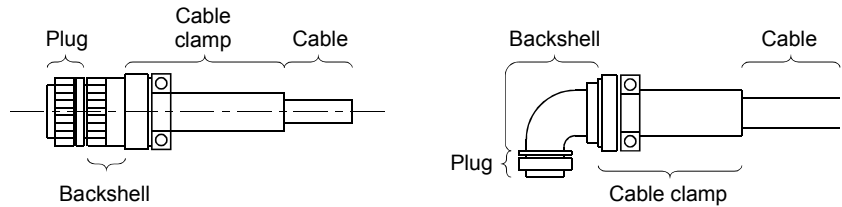

Connector configuration	Feature	Plug (DDK)		Backshell (DDK)	Cable clamp (DDK)		Servo motor encoder connector
		Type	Model name		Cable OD [mm]	Model name	
M	IP67 EN compliant	Straight	D/MS3106A20-29S	CE02-20BS-D	$\phi 6.8$ to $\phi 10$	CE3057-12A-3-D	D/MS3102A20-29P
			Angle				

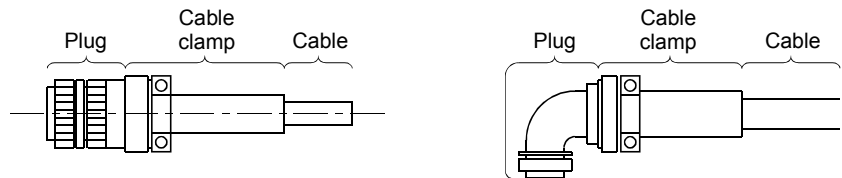

Connector configuration	Feature	Plug (DDK)		Cable clamp (DDK)		Servo motor encoder connector
		Type	Model name	Cable OD [mm]	Model name	
N	(Note) General environment	Straight	D/MS3106B20-29S	$\phi 15.9$ or less (Bushing ID)	D/MS3057-12A	D/MS3102A20-29P
			Angle			

Note. Not compliant with the EN.

### 3. CONNECTORS USED FOR SERVO MOTOR WIRING

#### 3.5 Wiring connectors (Connector configurations P · Q)

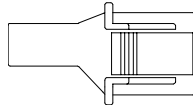

Connector configuration	Connector (JST)					Servo motor encoder connector
	Tab housing	Tab contact	Applicable wire size	Insulator OD [mm]	Crimping tool	
P	J21DPM-10V-KX	SJ2M-01GF-M1.0N	0.20mm <sup>2</sup> to 0.50mm <sup>2</sup> (AWG24 to 20)	φ1.11 to φ1.53	YRS-8861	J21DF-10V-KX-L

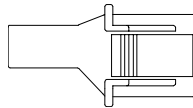

Connector configuration	Connector (JST)					Servo motor encoder connector
	Tab housing	Tab contact	Applicable wire size	Insulator OD [mm]	Crimping tool	
Q	J21DPM-06V-KX	SJ2M-21GF-M1.0N	0.30mm <sup>2</sup> to 0.75mm <sup>2</sup>	φ1.30 to φ1.90	YRF-1120	J21DF-06V-KX-L

# 4. CONNECTOR OUTLINE DRAWINGS

## 4. CONNECTOR OUTLINE DRAWINGS

The connector outline drawings for wiring the servo motor are shown below.

### (1) TE Connectivity 2174053-1

[Unit: mm]

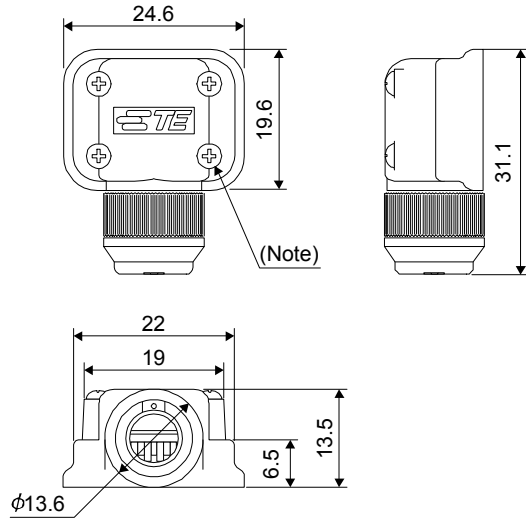

Note. The recommended screw tightening torque is 0.1N · m.

Crimping tool: 1596970-1 (for ground clip)  
1596847-1 (for receptacle contact)

### (2) JAE JN4FT02SJ1-R

[Unit: mm]

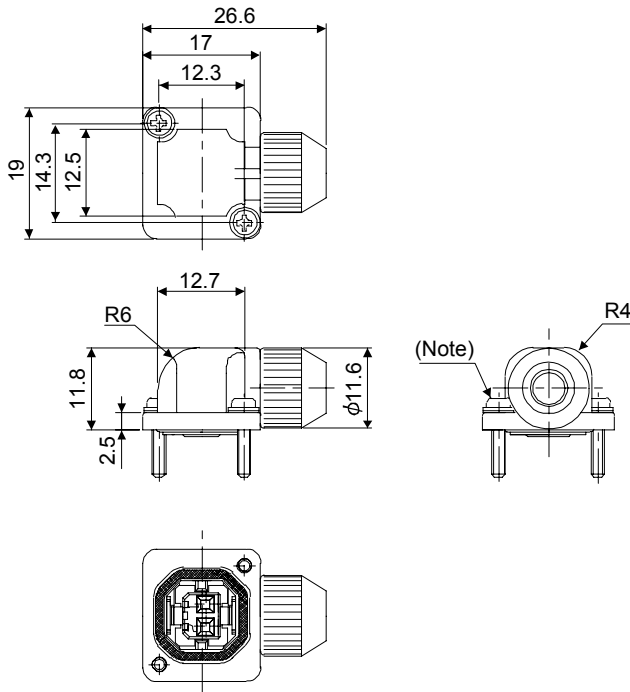

Note. The recommended screw tightening torque is 0.2N · m.

Crimping tool: CT160-3-TMH5B

## 4. CONNECTOR OUTLINE DRAWINGS

KN4FT04SJ1-R

[Unit: mm]

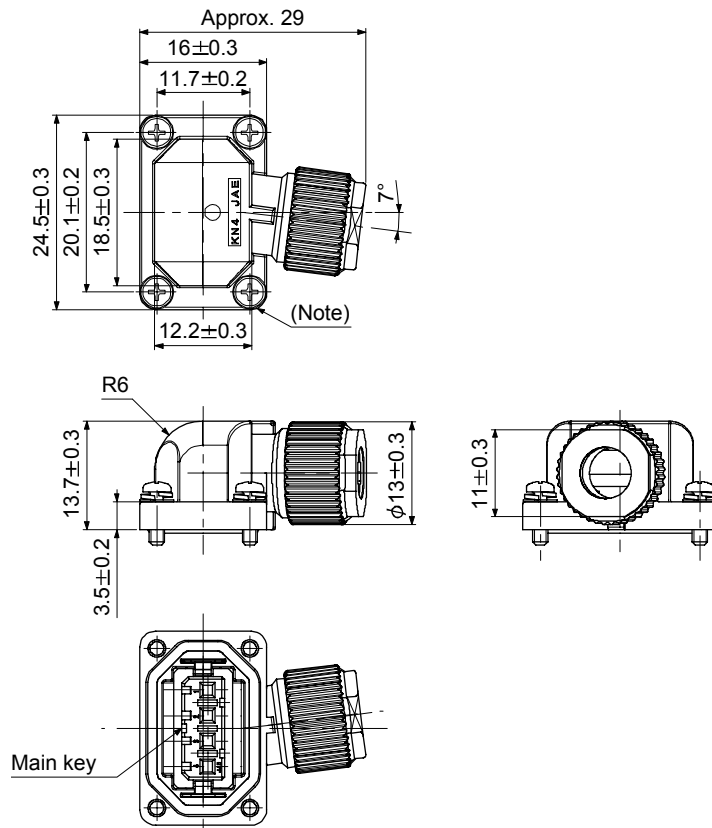

Note. The recommended screw tightening torque is 0.2N · m.

Crimping tool: CT160-3-TMH5B

### (3) DDK

(a) CMV1-SP10S-M□/CMV1-SP2S-□

Refer to section 3.3 for details of crimping tools.

[Unit: mm]

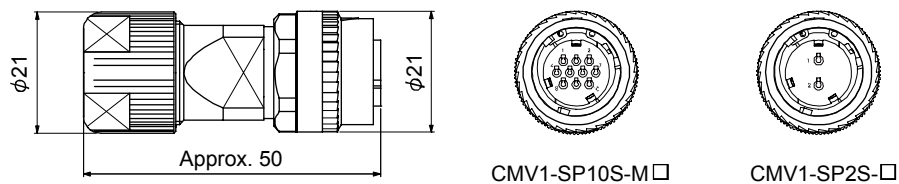

CMV1-SP10S-M□

CMV1-SP2S-□

## 4. CONNECTOR OUTLINE DRAWINGS

### (b) CMV1-AP10S-M□/CMV1-AP2S-□

Refer to section 3.3 for details of crimping tools.

[Unit: mm]

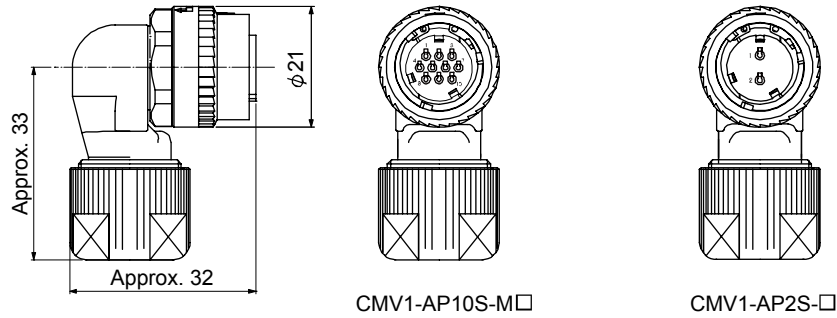

### (c) CE05-6A□-□SD-D-BSS

[Unit: mm]

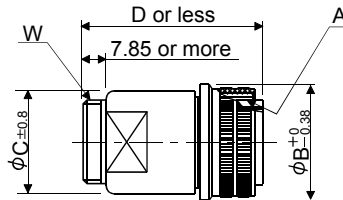

Model name	A	B	C	D	W
CE05-6A18-10SD-D-BSS	1 1/8-18UNEF-2B	34.13	32.1	57	1-20UNEF-2A
CE05-6A22-22SD-D-BSS	1 3/8-18UNEF-2B	40.48	38.3	61	1 3/16-18UNEF-2A
CE05-6A22-23SD-D-BSS	1 3/8-18UNEF-2B	40.48	38.3	61	1 3/16-18UNEF-2A
CE05-6A24-10SD-D-BSS	1 1/2-18UNEF-2B	43.63	42.0	68	1 7/16-18UNEF-2A
CE05-6A32-17SD-D-BSS	2-18UNS-2B	56.33	54.20	79	1 3/4-18UNS-2A

### (d) CE05-8A□-□SD-D-BAS

[Unit: mm]

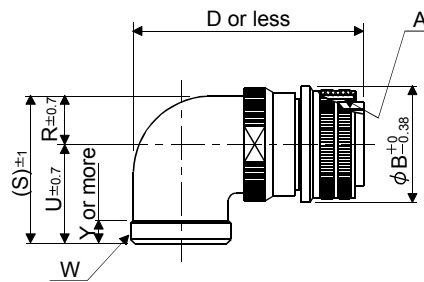

Model name	A	B	D	W	R	U	(S)	Y
CE05-8A18-10SD-D-BAS	1 1/8-18UNEF-2B	34.13	69.5	1-20UNEF-2A	13.2	30.2	43.4	7.5
CE05-8A22-22SD-D-BAS	1 3/8-18UNEF-2B	40.48	75.5	1 3/16-18UNEF-2A	16.3	33.3	49.6	7.5
CE05-8A22-23SD-D-BAS	1 3/8-18UNEF-2B	40.48	75.5	1 3/16-18UNEF-2A	16.3	33.3	49.6	7.5
CE05-8A24-10SD-D-BAS	1 1/2-18UNEF-2B	43.63	86.3	1 7/16-18UNEF-2A	18.2	36.5	54.7	7.5
CE05-8A32-17SD-D-BAS	2-18UNS-2B	56.33	93.5	1 3/4-18UNS-2A	24.6	44.5	61.9	8.5

## 4. CONNECTOR OUTLINE DRAWINGS

(e) CE3057-□A-□-D

[Unit: mm]

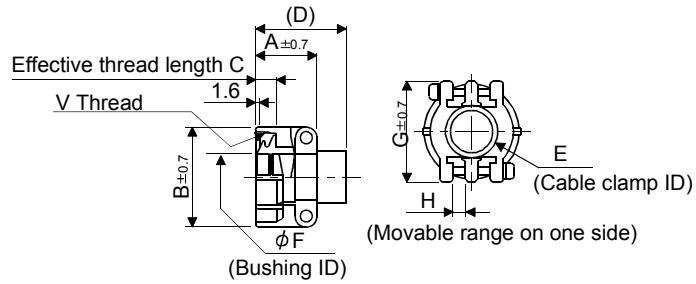

Model name	Shell size	A	B	C	D	E	F	G	H	V	Bushing	Cable range
CE3057-10A-1-D	18	23.8	30.1	10.3	41.3	15.9	14.1	31.7	3.2	1-20UNEF	CE3420-10-1	φ10.5 to φ14.1
CE3057-10A-2-D							11.0				CE3420-10-2	φ8.5 to φ11
CE3057-12A-1-D	22	23.8	35	10.3	41.3	19	16.0	37.3	4.0	1 3/16-18UNEF	CE3420-12-1	φ12.5 to φ16
CE3057-12A-2-D							13.0				CE3420-12-2	φ9.5 to φ13
CE3057-16A-1-D	24	26.2	42.1	10.3	41.3	23.8	19.1	42.9	4.8	1 7/16-18UNEF	CE3420-16-1	φ15 to φ19.1
CE3057-16A-2-D							15.5				CE3420-16-2	φ13 to φ15.5
CE3057-20A-1-D	32	27.8	51.6	11.9	43	31.7	23.8	51.6	6.3	1 3/4-18UNS-2B	CE3420-20-1	φ22 to φ23.8

(f) D/MS3106B□-□S

[Unit: mm]

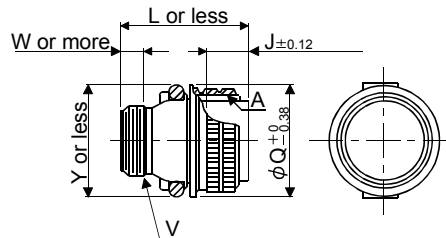

Model name	A	J	L	Q	V	W	Y
D/MS3106B18-10S	1 1/8-18UNEF	18.26	52.37	34.13	1-20UNEF	9.53	42
D/MS3106B20-29S	1 1/4-18UNEF	18.26	55.57	37.28	1 3/16-18UNEF	9.53	47
D/MS3106B22-22S	1 3/8-18UNEF	18.26	56.57	40.48	1 3/16-18UNEF	9.53	50
D/MS3106B22-23S	1 3/8-18UNEF	18.26	55.57	40.48	1 3/16-18UNEF	9.53	50
D/MS3106B24-10S	1 1/2-18UNEF	18.26	58.72	43.63	1 7/16-18UNEF	9.53	53
D/MS3106B32-17S	2-18UNS	18.26	61.92	56.33	1 3/4-18UNS	11.13	66

## 4. CONNECTOR OUTLINE DRAWINGS

(g) D/MS3108B□-□S

[Unit: mm]

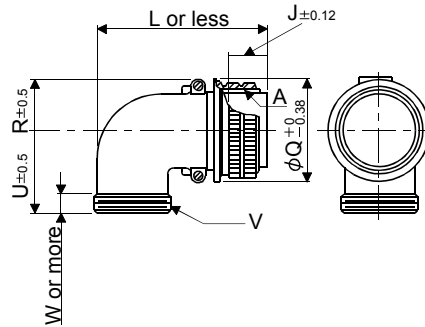

Model name	A	J	L	Q	R	U	V	W
D/MS3108B18-10S	1 1/8-18UNEF	18.26	68.27	34.13	20.5	30.2	1-20UNEF	9.53
D/MS3108B20-29S	1 1/4-18UNEF	18.26	76.98	37.28	22.5	33.3	1 3/16-18UNEF	9.53
D/MS3108B22-22S	1 3/8-18UNEF	18.26	76.98	40.48	24.1	33.3	1 3/16-18UNEF-2A	9.53
D/MS3108B22-23S	1 3/8-18UNEF	18.26	76.98	40.48	24.1	33.3	1 3/16-18UNEF	9.53
D/MS3108B24-10S	1 1/2-18UNEF	18.26	86.51	43.63	25.6	36.5	1 7/16-18UNEF	9.53
D/MS3108B32-17S	2-18UNS	18.26	95.25	56.33	32.8	44.4	1 3/4-18UNS	11.13

(h) D/MS3057-□A

[Unit: mm]

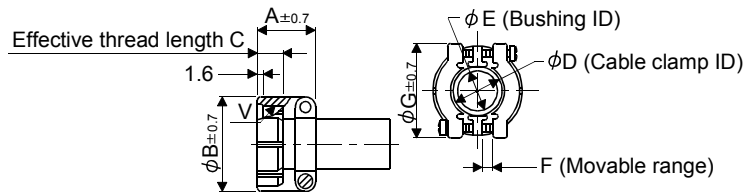

Model name	Shell size	A	B	C	D	E	F	G	V	Bushing
D/MS3057-10A	18	23.8	30.1	10.3	15.9	14.3	3.2	31.7	1-20UNEF	AN3420-10
D/MS3057-12A	22	23.8	35.0	10.3	19.0	15.9	4.0	37.3	1 3/16-18UNEF-2A	AN3420-12
D/MS3057-16A	24 · 28	26.2	42.1	10.3	23.8	19.1	4.8	42.9	1 7/16-18UNEF	AN3420-16
D/MS3057-20A	32	27.8	51.6	11.9	31.7	23.8	6.3	51.6	1 3/4-18UNS	AN3420-20



## 4. CONNECTOR OUTLINE DRAWINGS

(i) D/MS3106□-□S(D190)

[Unit: mm]

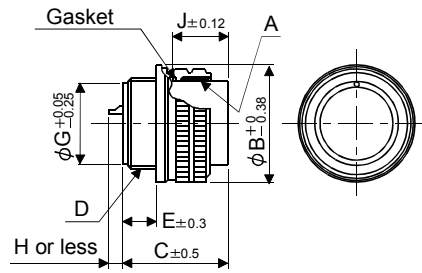

Model name	A	B	C	D	E	G	J
D/MS3106A10SL-4S(D190)	5/8-24UNEF-2B	22.22	23.3	9/16-24UNEF-2A	7.5	12.5	13.49
D/MS3106A20-29S(D190)	1 1/4-18UNEF-2B	37.28	34.11	1 1/8-18UNEF-2A	12.16	26.8	18.26

H	Contact size
	#16
8 or less	

(j) CM10-SP10S-VP-M • CM10-SP2S-VP-S/M/L

[Unit: mm]

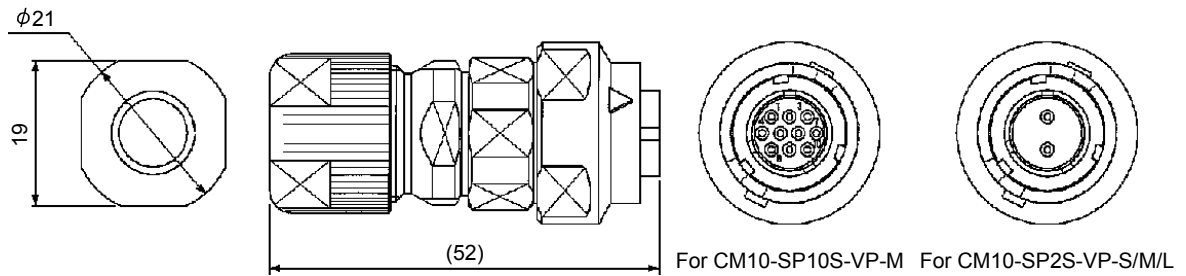

(k) CM10-AP10S-VP-M • CM10-AP2S-VP-S/M/L

[Unit: mm]

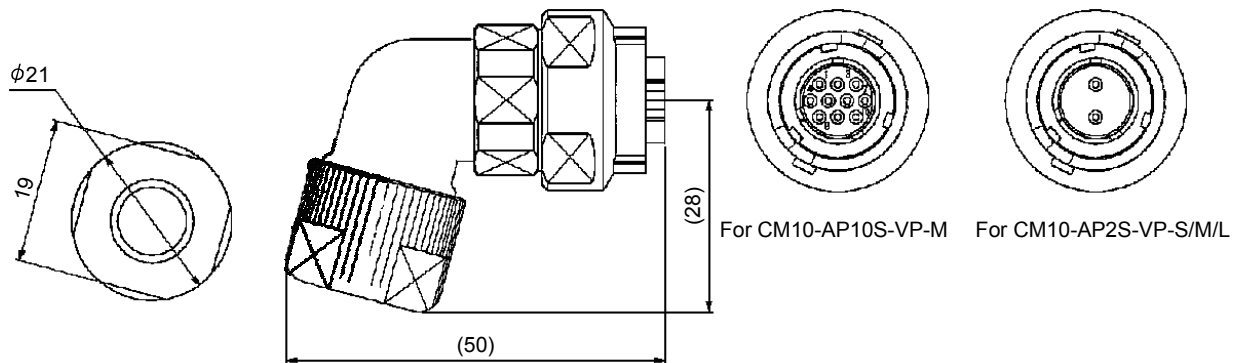

## 4. CONNECTOR OUTLINE DRAWINGS

(I) CE05-6A32-17SD-D

[Unit: mm]

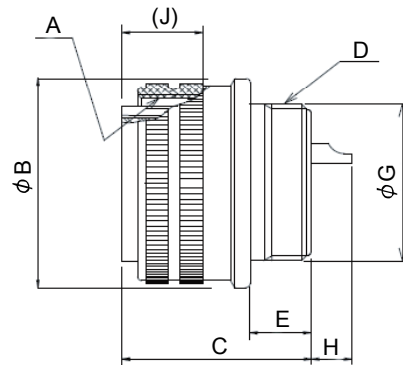

Model name	A	B	C	D	E	G	H	J
CE05-6A32-17SD-D	2-18UNS-2B	56.33	37.0	1 7/8-16UN-2A	13.14	45.3	9.2	19.4

<Daiwa Dengyo> YSO10-5 to 8 · YLO10-5 to 8

[Unit: mm]

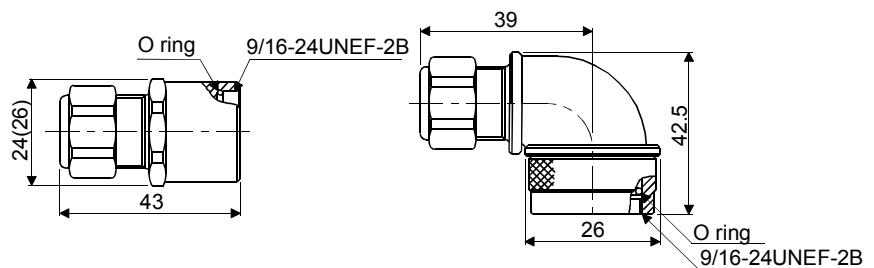

<Nippon Flex>

[Unit: mm]

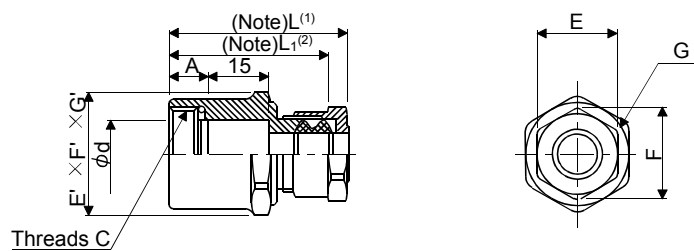

Model	Threads C	Applicable cable diameter	A	d	Tightening nut			Nipple body			L	L <sub>1</sub>
					E Width across flats	F Width across corners	G Number of corners	E' Width across flats	F' Width across corners	G' Number of corners		
ACS-08RL-MS10F	9/16-24UNEF-2B	φ4.0 to φ8.0	6	11.0	20	22.0	6	20	22.0	6	45	40
ACS-12RL-MS10F	9/16-24UNEF-2B	φ8.0 to φ12.0	6	11.0	24	26.4	6	24	26.4	6	46	41

Note. (1) indicates the reference dimension before assembling, and (2) the reference dimension after assembling.

## 4. CONNECTOR OUTLINE DRAWINGS

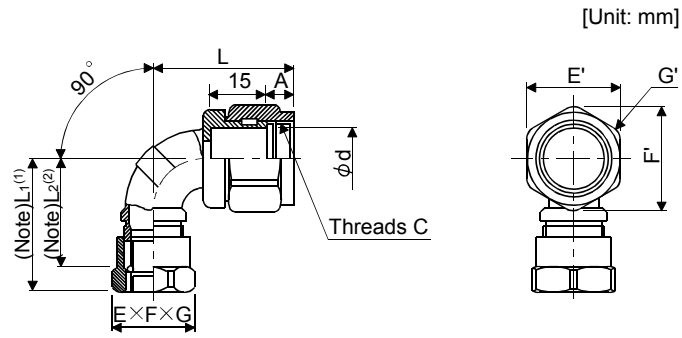

Model	Threads C	Applicable cable diameter	A	d	Tightening nut			Nipple body			L	L <sub>1</sub>	L <sub>2</sub>
					E Width across flats	F Width across corners	G Number of corners	E' Width across flats	F' Width across corners	G' Number of corners			
ACA-08RL-MS10F	9/16-24UNE-F-2B	φ4.0 to φ8.0	6	10.0	20	22.0	6	20	22.0	6	35	37	32
ACA-12RL-MS10F	9/16-24UNE-F-2B	φ8.0 to φ12.0	6	10.0	24	26.4	6	20	22.0	6	40	43	38

Note. (1) indicates the reference dimension before assembling, and (2) the reference dimension after assembling.

## 5. CALCULATION METHODS FOR DESIGNING

### 5. CALCULATION METHODS FOR DESIGNING

#### 5.1 Specification symbol list

The following symbols are required for selecting the proper servo.

$T_a$	: Acceleration torque	[N · m]	$\mu$	: Friction coefficient	
$T_d$	: Deceleration torque	[N · m]	$\pi$	: Circle ratio (3.14)	
$T_{Ma}$	: Servo motor torque necessary for acceleration	[N · m]	$P_t$	: Number of feedback pulses in position control mode	[pulse/rev]
$T_{Md}$	: Servo motor torque necessary for deceleration	[N · m]	$f$	: Input pulse frequency in position control mode	[pps]
$T_L$	: Load torque converted into equivalent value on servo motor shaft	[N · m]	$f_0$	: Input pulse frequency during fast feed in position control mode	[pps]
$T_{LM}$	: Load torque converted into equivalent value on servo motor shaft during stop	[N · m]	$t_{psa}$	: Acceleration time constant of pulse frequency command in position control mode	[s]
$T_U$	: Unbalance torque	[N · m]	$t_{psd}$	: Deceleration time constant of pulse frequency command in position control mode	[s]
$T_F$	: Load friction torque	[N · m]	$K_p$	: Position control gain 1	[rad/s]
$T_B$	: Brake static friction torque		$T_p$	: Position control time constant ( $T_p=1/K_p$ )	[s]
$T_{L0}$	: Load torque on load shaft	[N · m]	$\Delta \ell$	: Feed per feedback pulse in position control mode	[mm/pulse]
$T_{rms}$	: Continuous effective load torque converted into equivalent value on servo motor shaft	[N · m]	$\Delta \ell_0$	: Feed per command pulse in position control mode	[mm/pulse]
$J_L$	: Load inertia moment converted into equivalent value on servo motor shaft	$[\times 10^{-4} \text{kg} \cdot \text{m}^2]$	$\ell$	: Feed	[mm]
$J_{L0}$	: Load inertia moment on load shaft	$[\times 10^{-4} \text{kg} \cdot \text{m}^2]$	$P$	: Number of internal command pulses	[pulse]
$J_M$	: Servo motor's rotor inertia moment	$[\times 10^{-4} \text{kg} \cdot \text{m}^2]$	$t_s$	: Internal settling time	[s]
$N$	: Servo motor speed	[r/min]	$t_o$	: Positioning time	[s]
$N_0$	: Servo motor speed during fast feed	[r/min]	$t_c$	: Time at constant speed of servo motor in 1 cycle	[s]
$N_{L0}$	: Load shaft speed during fast feed	[r/min]	$t_{\ell}$	: Stopping time in 1 cycle	[s]
$V$	: Moving part speed	[mm/min]	$\Delta \varepsilon$	: Positioning accuracy	[mm]
$V_0$	: Moving part speed during fast feed	[mm/min]	$\varepsilon$	: Number of droop pulses	[pulse]
$P_b$	: Ball screw lead	[mm]	$\Delta S$	: Feed per servo motor revolution	[mm/rev]
$Z_1$	: Number of gear teeth on servo motor shaft		$W$	: Mass	[kg]
$Z_2$	: Number of gear teeth on load gear		$L_{max}$	: Maximum coasting distance	[mm]
$n$	: Gear ratio $n = \frac{Z_2}{Z_1}$ Speed reduced when $n > 1$ , Speed increased when $n < 1$				
$\eta$	: Drive system efficiency				
$g$	: Gravitational acceleration (9.8[m/s <sup>2</sup> ])				

## 5. CALCULATION METHODS FOR DESIGNING

### 5.2 Position resolution and electronic gear setting

Position resolution (travel distance per pulse  $\Delta \ell$ ) is determined by travel distance per servo motor revolution  $\Delta S$  and the number of encoder feedback pulses  $P_t$ , and is represented by Equation 5.1. As the number of feedback pulses depends on the servo motor series, Refer to "Standard specifications list" in the chapter of each servo motor series.

$$\Delta \ell = \frac{\Delta S}{P_t} \dots\dots\dots(5.1)$$

$\Delta \ell$  : Travel distance per pulse [mm/pulse]  
 $\Delta S$  : Travel distance per servo motor revolution [mm/rev]  
 $P_t$  : Number of feedback pulses [pulse/rev]

Since  $\Delta \ell$  has the relationship represented by Equation 5.1, its value is fixed in the control system after the drive system and encoder have been determined. However, travel distance per command pulse can be set as desired using the parameters.

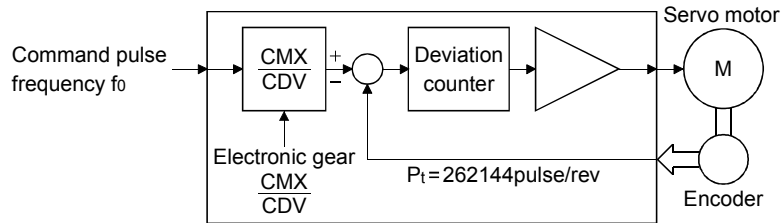

As shown above, command pulses are multiplied by CMX/CDV set in the parameters to be position control pulses. Travel distance per command pulse  $\Delta \ell_0$  is expressed by Equation 5.2.

$$\Delta \ell_0 = \frac{P_t}{\Delta S} \cdot \frac{CMX}{CDV} = \Delta \ell \cdot \frac{CMX}{CDV} \dots\dots\dots(5.2)$$

CMX : Electronic gear (Command pulse multiplication numerator)  
 CDV : Electronic gear (Command pulse multiplication denominator)

Using the above relationship, travel distance per command pulse can be set to a value without fraction.

[Setting example]

Find a parameter value for  $\Delta \ell_0 = 0.01$  [mm] in a drive system where ball screw lead  $PB = 10$  [mm/pulse] and reduction ratio  $1/n = 1$ .

The encoder feedback pulses  $P_t$  of the HF-KP = 262144 [pulses/rev].

Since  $\Delta s = 10$  [mm/rev], the following is obtained according to Equation 5.2.

$$\frac{CMX}{CDV} = \Delta \ell_0 \cdot \frac{P_t}{\Delta S} = 0.01 \cdot \frac{262144}{10} = \frac{32768}{125}$$

<Relationship between position resolution  $\Delta \ell$  and overall accuracy>

Positioning accuracy of machine is the sum of electrical errors and mechanical errors. Normally, provisions should be made so that positioning accuracy are not affected by electrical system errors. As a guideline, Equation 5.3 should be satisfied.

$$\Delta \ell < \left[ \frac{1}{5} \text{ to } \frac{1}{10} \right] \cdot D \varepsilon \dots\dots\dots(5.3)$$

where,  $\Delta \ell$  : Travel distance per feedback pulse [mm/pulse]  
 $D \varepsilon$  : Positioning accuracy [mm]

## 5. CALCULATION METHODS FOR DESIGNING

### 5.3 Speed and command pulse frequency

The servo motor is run at a speed where the command pulses and feedback pulses are equivalent. Therefore, the command pulse frequency and feedback pulse frequency are equivalent. The relation including the parameter settings (CMX, CDV) is as indicated below (refer to the following diagram).

$$f_0 \cdot \frac{CMX}{CDV} = P_t \cdot \frac{N_0}{60} \dots\dots\dots (5.4)$$

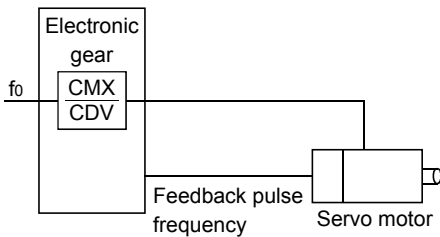

- f<sub>0</sub> : Command pulse frequency (Differential line driver) [pps]
- CMX : Electronic gear (Commanded pulse multiplication numerator)
- CDV : Electronic gear (Commanded pulse multiplication denominator)
- N<sub>0</sub> : Servo motor speed [r/min]
- P<sub>t</sub> : Number of feedback pulses [pulses/rev] (P<sub>t</sub> = 262144 for HF-KP)

According to Equation 5.4, the following equations may be used to obtain the electronic gear and command pulse frequency to rotate the servo motor at N<sub>0</sub>.

• Electronic gear

$$\frac{CMX}{CDV} = P_t \cdot \frac{N_0}{60} \cdot \frac{1}{f_0} \dots\dots\dots (5.5)$$

• Command pulse frequency

$$f_0 = P_t \cdot \frac{N_0}{60} \cdot \frac{CDV}{CMX} \dots\dots\dots (5.6)$$

[Setting example]

Obtain the command pulse frequency required to run the HF-KP at 3000r/min.

When the electronic gear ratio 1 (initial parameter value) is used, the following result is found according to Equation 5.6.

$$f_0 = 262144 \cdot \frac{N_0}{60} \cdot \frac{CDV}{CMX}$$

(Command pulse frequency)

$$= 262144 \cdot \frac{3000}{60} \cdot 1$$

$$= 13107200[\text{pps}]$$

However, as the maximum input command pulse frequency in the differential line driver type is 1Mpps, for general-purpose servo 13107200pps cannot be entered.

To run the servo motor at the speed of 3000r/min at not more than 1Mpps, the electronic gear setting must be changed. This electronic gear is found by Equation 5.5.

$$\frac{CMX}{CDV} = 262144 \cdot \frac{3000}{60} \cdot \frac{1}{1 \cdot 10^6}$$

(Electronic gear)

$$= \frac{8192}{625}$$

Therefore, the parameters are set to CMX = 8192 and CDV = 625.

## 5. CALCULATION METHODS FOR DESIGNING

### 5.4 Stopping characteristics

#### (1) Droop pulses ( $\varepsilon$ )

When a pulse train command is used to run the servo motor, there is a relationship between the command pulse frequency and servo motor speed as shown in the figure. The difference between the command pulses and feedback pulses during acceleration are called droop pulses, which are accumulated in the servo amplifier (drive unit) deviation counter. Equation 5.7 defines a relationship between the command pulse frequency ( $f$ ) and position control gain  $1(K_p)$ .

$$\varepsilon \cong \frac{f_0}{K_p} [\text{pulse}] \dots \dots \dots (5.7)$$

Supposing that the value of position control gain  $1$  is  $70$  [rad/s], the droop pulses during operation will be as follows at the command pulse frequency of  $200$  [kpps] according to Equation 5.7.

$$\varepsilon \cong \frac{200 \cdot 10^3}{1} \cong 2858 [\text{pulse}]$$

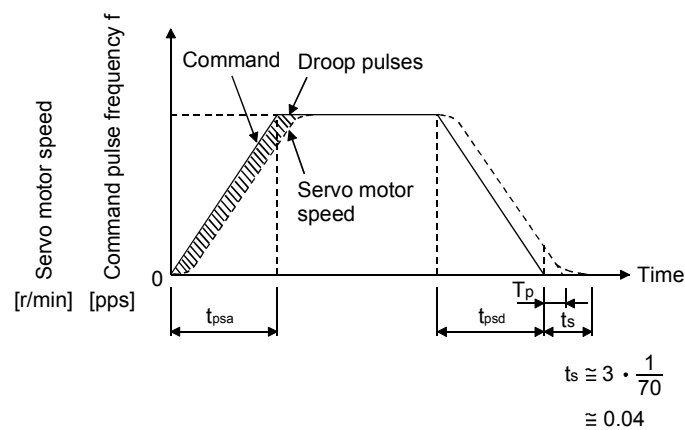

#### (2) Settling time ( $t_s$ ) during linear acceleration/deceleration

Since droop pulses still exist when there are no command pulses, settling time ( $t_s$ ) is required until the servo motor stops. Set the operation pattern in consideration for the settling time. The settling time ( $t_s$ ) value is obtained according to Equation 5.8.

$$\begin{aligned} t_s &\cong 3 \cdot T_p \\ &= 3 \cdot \frac{1}{K_p} [\text{s}] \dots \dots \dots (5.8) \end{aligned}$$

\*When  $K_p = 70$  [rad/s],  $t_s \cong 0.04$  [s]. (Refer to the above diagram.)

The settling time ( $t_s$ ) indicates the time required for the servo motor to stop in the necessary positioning accuracy range. This does not always mean that the servo motor has stopped completely. Thus, especially when the servo motor is used in high-duty operation and positioning accuracy has no margin for travel distance per pulse ( $\Delta \ell$ ), the value obtained by Equation 5.8 must be increased.

The settling time ( $t_s$ ) will vary with the moving part conditions. Especially when the load friction torque is large, movement may be unstable near the stopping position.

## 5. CALCULATION METHODS FOR DESIGNING

### 5.5 Capacity selection

As a first step, confirm the load conditions and temporarily select the servo motor capacity. Then, determine the operation pattern, calculate required torques according to the following equations, and check that the servo motor of the initially selected capacity may be used for operation .

#### (1) Initial selection of servo motor capacity

After calculating the load torque ( $T_L$ ) and load inertia moment ( $J_L$ ), select a servo motor which will satisfy the following two relationships.

Servo motor's rated torque  $> T_L$

Servo motor  $J_M > J_L/m$

$m = 3$	: High duty (more than 100 times/min.) Settling time 40ms or less
$m = 5$	: Middle duty (60 to 100 times/min.) Settling time 100ms or less
$m = \text{permissible load inertia moment}$	: Low duty (less than 60 times/min.) Settling time more than 100ms

Find the acceleration and deceleration torques and continuous effective load torque as described in (2) to make a final selection. For high-duty positioning, the load inertia moment ( $J_L$ ) value should be as small as possible. If positioning is infrequent as in line control, the load inertia moment ( $J_L$ ) value may be slightly larger than in the above conditions.

#### (2) Acceleration and deceleration torques

The following equations are used to calculate the acceleration and deceleration torques in the following operation pattern.

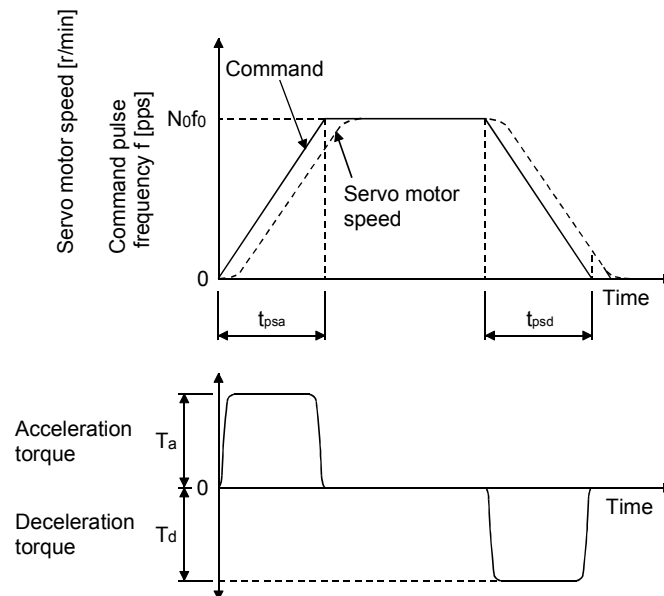

$$\bullet \text{ Acceleration torque } T_a = \frac{(J_L + J_M) \cdot N_0}{9.55 \cdot 10^4} \cdot \frac{1}{t_{psa}} \dots \dots \dots (5.9)$$

$$\bullet \text{ Deceleration torque } T_b = \frac{(J_L + J_M) \cdot N_0}{9.55 \cdot 10^4} \cdot \frac{1}{t_{psd}} \dots \dots \dots (5.10)$$



## 5. CALCULATION METHODS FOR DESIGNING

### (3) Torques required for operation

POINT
<ul style="list-style-type: none"> <li>Consider individual machine differences, and do not adjust gain too strictly. It is recommended to keep the servo motor torque to 90% or less of the maximum torque of the servo motor during the operation.</li> </ul>

Torques required for the servo motor are the highest during acceleration. If the servo motor torque found with equation 5.11 to 5.13 exceed the maximum torque, the motor will not accelerate as commands. Set the calculated value within the servo motor's maximum torque. Since a friction load is normally applied during deceleration, only the acceleration torque needs to be considered. In the regenerative mode, the value found by equation 5.13 is negative.

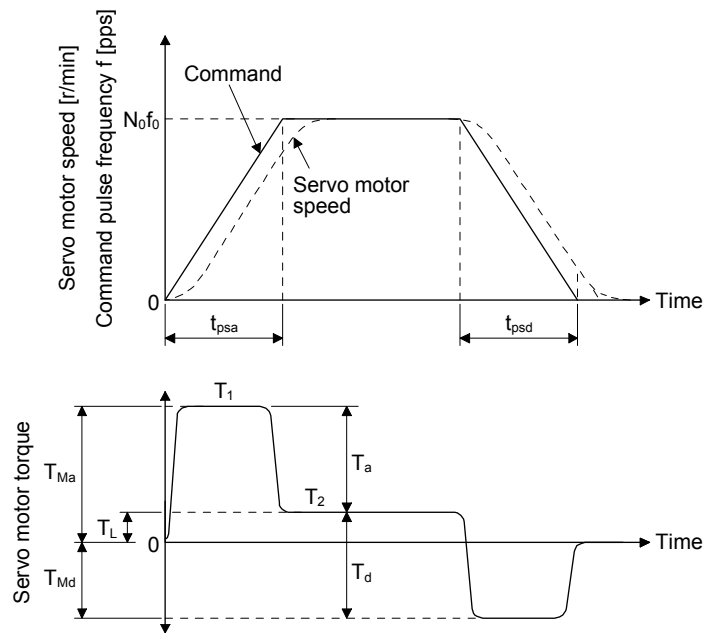

$$T_1 = T_{Ma} = T_a + T_L \dots\dots\dots (5.11)$$

$$T_2 = T_L \dots\dots\dots (5.12)$$

$$T_3 = T_{Md} = -T_d + T_L \dots\dots\dots (5.13)$$

## 5. CALCULATION METHODS FOR DESIGNING

### (4) Continuous effective load torque

If the torque required for the servo motor changes with time, the continuous effective load torque should be lower than the rated torque of the servo motor. There may be a servo motor torque delay at the start of acceleration or deceleration due to a delay in the control system. To simplify the calculation, however, it is assumed that constant acceleration and deceleration torques are applied during  $t_{psa}$  and  $t_{psd}$ . The following equation is used to calculate the continuous effective load torque in the following operation pattern.  $T_{LH}$  indicates the torque applied during a servo motor stop. A large torque may be applied especially during a stop in vertical motion applications, and this must be fully taken into consideration. During vertical drive, the unbalanced torque  $T_U$  will become  $T_{LH}$ .

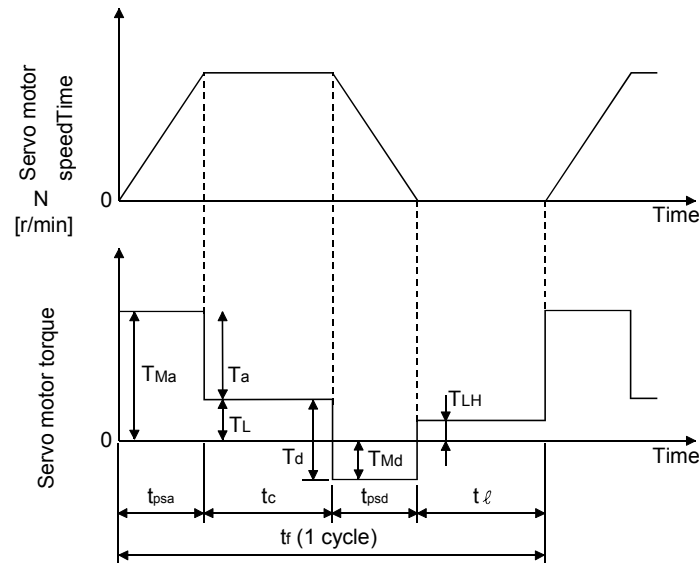

$$T_{rms} = \sqrt{\frac{T_{Ma}^2 \cdot t_{psa} + T_L^2 \cdot t_c + T_{Md}^2 \cdot t_{psd} + T_{LH}^2 \cdot t_l}{t_f}} \dots\dots\dots (5.14)$$

## 5. CALCULATION METHODS FOR DESIGNING

### 5.6 Load torque equations

Typical load torque equations are indicated below.

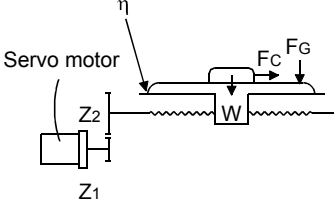
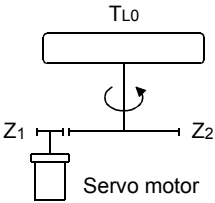
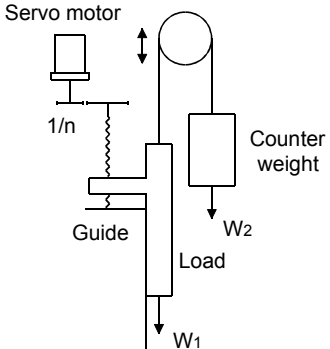
Type	Mechanism	Equation
Linear movement		$T_L = \frac{F}{2 \cdot 10^3 \cdot \pi \cdot \eta} \cdot \frac{V}{N} = \frac{F \cdot \Delta S}{2 \cdot 10^3 \cdot \pi \cdot \eta} \dots\dots\dots (5.15)$ <p>F : Force in the axial direction of the machine in linear motion [N]  F in Equation 5.15 is obtained with Equation 5.16 when the table is moved, for example, as shown in the left diagram.</p> $F = F_c + \mu \cdot (W \cdot g + F_G) \dots\dots\dots (5.16)$ <p>F<sub>c</sub>: Force applied in the axial direction of the moving part [N]  F<sub>G</sub>: Tightening force of the table guide surface [N]  W : Full mass of the moving part [kg]</p>
Rotary movement		$T_L + \frac{1}{n} \cdot \frac{1}{\eta} \cdot T_{L0} + T_F \dots\dots\dots (5.17)$ <p>T<sub>F</sub> : Load friction torque converted into equivalent value on servo motor shaft [N · m]</p>
Vertical movement		<p>During rise</p> $T_L = T_U + T_F \dots\dots\dots (5.18)$ <p>During fall</p> $T_L = -T_U \cdot \eta^2 + T_F \dots\dots\dots (5.19)$ <p>T<sub>F</sub>: Friction torque of the moving part [N · m]</p> $T_U = \frac{(W_1 - W_2) \cdot g}{2 \cdot 10^3 \cdot \pi \cdot \eta} \cdot \frac{V}{N} = \frac{(W_1 - W_2) \cdot g \cdot \Delta S}{2 \cdot 10^3 \cdot \pi \cdot \eta} \dots\dots\dots (5.20)$ $T_F = \frac{\mu (W_1 + W_2) \cdot g \cdot \Delta S}{2 \cdot 10^3 \cdot \pi \cdot \eta} \dots\dots\dots (5.21)$ <p>W<sub>1</sub>: Mass of load [kg]  W<sub>2</sub>: Mass of counterweight [kg]</p>

## 5. CALCULATION METHODS FOR DESIGNING

### 5.7 Load inertia moment equations

Typical load inertia moment equations are indicated below.

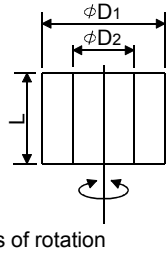
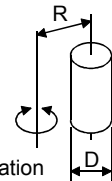
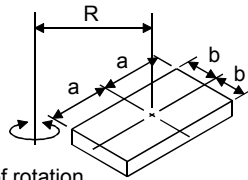
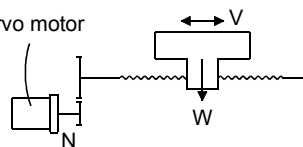
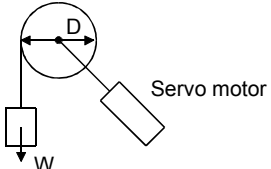
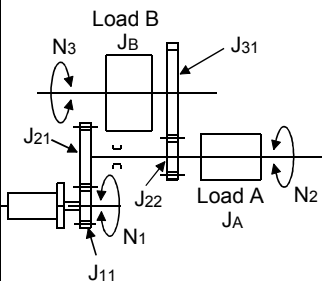
Type	Mechanism	Equation
Cylinder	<p>Axis of rotation is on the cylinder center</p> 	$J_{L0} = \frac{\pi \cdot \rho \cdot L}{32} \cdot (D_1^4 - D_2^4) = \frac{W}{8} \cdot (D_1^2 + D_2^2) \dots \dots \dots (5.22)$ <p> <math>\rho</math> : Cylinder material density [kg/cm<sup>3</sup>]                      L : Cylinder length [cm]                      D1: Cylinder outside diameter [cm]                      D2: Cylinder inside diameter [cm]                      W : Cylinder mass [kg]                 </p> <p>Reference data: material density                      Iron : <math>7.8 \cdot 10^{-3}</math> [kg/cm<sup>3</sup>]                      Aluminum : <math>2.7 \cdot 10^{-3}</math> [kg/cm<sup>3</sup>]                      Copper : <math>8.96 \cdot 10^{-3}</math> [kg/cm<sup>3</sup>]</p>
	<p>Axis of rotation is off the cylinder center</p> 	$J_{L0} = \frac{W}{8} \cdot (D^2 + 8R^2) \dots \dots \dots (5.23)$
Square block		$J_{L0} = W \cdot \left( \frac{a^2 + b^2}{3} + R^2 \right) \dots \dots \dots (5.24)$ <p>                     W : Square block mass [kg]                      a, b, R : Left diagram [cm]                 </p>
Object which moves linearly	<p>Servo motor</p> 	$J_L = W \cdot \frac{V}{600 \cdot \omega} = W \cdot \left( \frac{1}{2 \cdot \pi \cdot N} \cdot \frac{V}{10} \right)^2 = W \cdot \left( \frac{\Delta S}{20 \cdot \pi} \right)^2 \dots \dots \dots (5.25)$ <p>                     V : Speed of object moving linearly [mm/min]                      ΔS : Moving distance of object moving linearly per servo motor revolution [mm/rev]                      W : Object mass [kg]                 </p>
Object that is hung with pulley		$J_L = W \cdot \left( \frac{D}{2} \right)^2 + J_p \dots \dots \dots (5.26)$ <p>                     J<sub>p</sub> : Pulley inertia moment [<math>\times 10^{-4}</math>kg · m<sup>2</sup>]                      D : Pulley diameter [cm]                      W : Object mass [kg]                 </p>
Converted load		$J_L = J_{11} + (J_{21} + J_{22} + J_A) \cdot \left( \frac{N_2}{N_1} \right)^2 + (J_{31} + J_B) \cdot \left( \frac{N_3}{N_1} \right)^2 \dots \dots \dots (5.27)$ <p>                     J<sub>A</sub>, J<sub>B</sub> : Inertia moments of loads A, B [<math>\times 10^{-4}</math>kg · m<sup>2</sup>]                      J<sub>11</sub> to J<sub>31</sub> : Inertia moments [<math>\times 10^{-4}</math>kg · m<sup>2</sup>]                      N<sub>1</sub> to N<sub>3</sub> : Speed of each shaft [r/min]                 </p>

## 5. CALCULATION METHODS FOR DESIGNING

### 5.8 Precautions for home position return

When a general positioning unit is used, the sequence of events is as shown in the following figure.

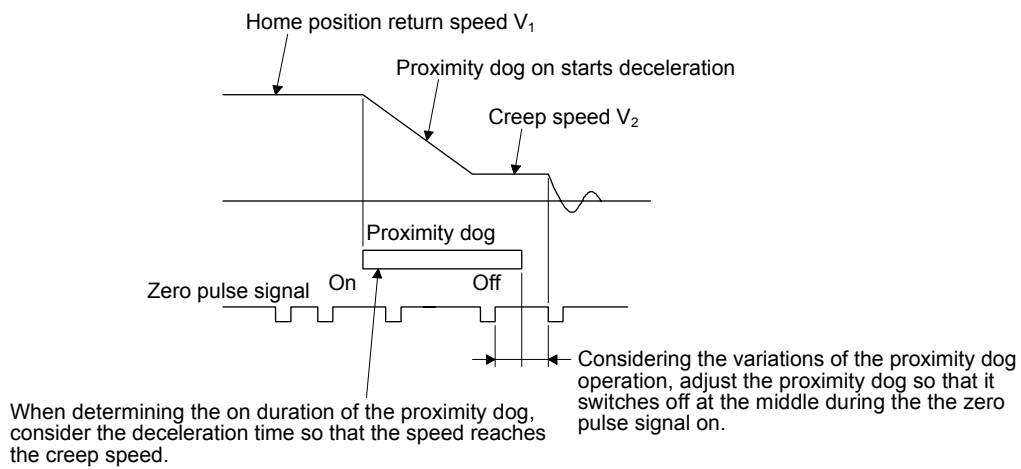

- (1) When determining the on duration of the proximity dog, consider the delay time of the control section and the deceleration time so that the creep speed is attained. If the proximity dog signal switches off during deceleration, precise home position return cannot be performed.

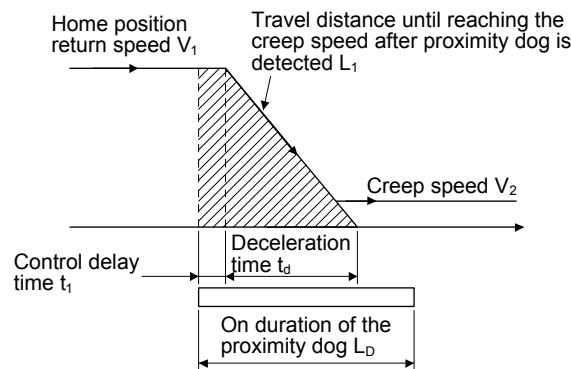

Travel distance  $L_1$  in the chart can be obtained by equation 5.28.

$$L_1 = \frac{1}{60} \cdot V_1 \cdot t_1 + \frac{1}{120} \cdot V_1 \cdot t_d \cdot \left\{ 1 - \left[ \frac{V_2}{V_1} \right]^2 \right\} + \frac{1}{60} \cdot V_1 \cdot T_p \dots \dots \dots (5.28)$$

ON duration of the actuator  $L_D$  [mm] must be longer than  $L_1$  obtained by Equation 5.28, as indicated in Equation 5.29.

$$L_D > L_1 \dots \dots \dots (5.29)$$

where,

$V_1, V_2$  : As shown in the chart [mm/min]

$t_1, t_d$  : As shown in the chart [s]

$L_1$  : As shown in the chart [mm]

$L_D$  : As shown in the chart [mm]

## 5. CALCULATION METHODS FOR DESIGNING

(2) Set the end (OFF position) of the actuator signal at the middle of two ON positions (Lows) of the zero pulse signal. If it is set near either ON position of the zero pulse signal, the positioning unit is liable to misdetect the zero pulse signal. In this case, a fault will occur, e.g. the home position will shift by one revolution of the servo motor.

The zero pulse output position can be confirmed by OP (encoder Z-phase pulse) on the external I/O signal display.

### 5.9 Selection example

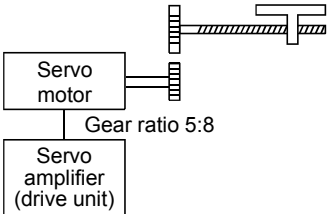
Machine specifications	Speed of moving part during fast feed	$V_0$	= 30000[mm/min]
	Feed per command pulse	$\Delta \ell$	= 10[ $\mu$ m]
	Travel	$\ell$	= 400[mm]
	Positioning time	$t_0$	= within 1[s]
	Number of feeds		40[times/min]
	Operation cycle	$t_f$	= 1.5[s]
	Gear ratio	$n$	= 8/5
	Moving part mass	$W$	= 60[kg]
	Drive system efficiency	$\eta$	= 0.8
	Friction coefficient	$\mu$	= 0.2
	Ball screw lead	$P_b$	= 16[mm]
Ball screw diameter		20[mm]	
Ball screw length		500[mm]	
Gear diameter (servo motor)		25[mm]	
Gear diameter (load shaft)		40[mm]	
Gear face width		10[mm]	

#### (1) Selection of control parameters

Setting of electronic gear (command pulse multiplication numerator, denominator)

There is the following relationship between the multiplication setting and travel per pulse  $\Delta \ell$ .

$$\Delta \ell = \frac{(\text{ball screw lead})}{262144 \cdot (\text{gear ration})} \cdot \left( \frac{\text{CMX}}{\text{CDV}} \right)$$

When the above machining specifications are substituted in the above equation.

$$10 \cdot 10^{-3} = \frac{16}{262144 \cdot 8/5} \cdot \frac{\text{CMX}}{\text{CDV}}$$

$$\frac{\text{CMX}}{\text{CDV}} = \frac{10}{1000} \cdot \frac{262144 \cdot 8/5}{16} = \frac{262144}{1000} = \frac{32768}{125}$$

Acceptable as CMX/CDV is within 1/10 to 2000.

#### (2) Servo motor speed

$$N_0 = \frac{V_0}{P_b} \cdot n = \frac{30000}{16} \cdot \frac{8}{5} = 3000[\text{r/min}]$$

## 5. CALCULATION METHODS FOR DESIGNING

(3) Acceleration/deceleration time constant

$$t_{psa} = t_{psd} = t_0 - \frac{\ell}{V_0/60} - t_s = 0.05[\text{s}]$$

$t_s$ : settling time. (Here, this is assumed to be 0.15s.)

(4) Operation pattern

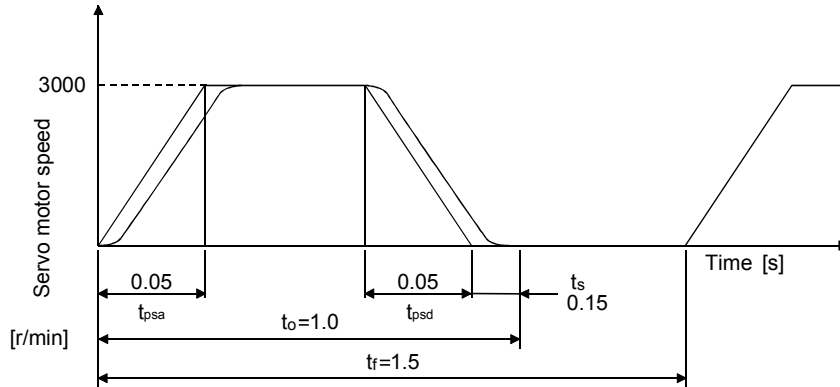

(5) Load torque (converted into equivalent value on servo motor shaft)

Travel distance per servo motor revolution

$$\Delta S = P_b \cdot \frac{1}{n} = 16 \cdot \frac{5}{8} = 10[\text{mm}]$$

$$T_L = \frac{\mu \cdot W \cdot g \cdot \Delta S}{2 \cdot 10^3 \cdot \pi \cdot \eta} = \frac{0.2 \cdot 60 \cdot 9.8 \cdot 10}{2 \cdot 10^3 \cdot 3.14 \cdot 0.8} = 0.23[\text{N} \cdot \text{m}]$$

## 5. CALCULATION METHODS FOR DESIGNING

---

(6) Load inertia moment (converted into equivalent value on servo motor shaft)

Moving part

$$J_{L1} = W \cdot \left( \frac{\Delta S}{20\pi} \right)^2 = 1.52 [\times 10^{-4} \text{kg} \cdot \text{m}^2]$$

Ball screw

$$J_{L2} = \frac{\pi \cdot \rho \cdot L}{32} \cdot D^4 \cdot \left( \frac{1}{n} \right)^2 = 0.24 [\times 10^{-4} \text{kg} \cdot \text{m}^2]$$

$$\rho = 7.8 \times 10^{-3} [\text{kg} \cdot \text{cm}^3]$$

Gear (servo motor shaft)

$$J_{L3} = \frac{\pi \cdot \rho \cdot L}{32} \cdot D^4 = 0.03 [\times 10^{-4} \text{kg} \cdot \text{m}^2]$$

Gear (load shaft)

$$J_{L4} = \frac{\pi \cdot \rho \cdot L}{32} \cdot D^4 \cdot \left( \frac{1}{n} \right)^2 = 0.08 [\times 10^{-4} \text{kg} \cdot \text{m}^2]$$

Full load inertia moment (converted into equivalent value on servo motor shaft)

$$J_L = J_{L1} + J_{L2} + J_{L3} + J_{L4} = 1.87 [\times 10^{-4} \text{kg} \cdot \text{m}^2]$$

(7) Temporary selection of servo motor

Selection conditions

(a) Load torque < servo motor's rated torque

(b) Full load inertia moment < 24 · servo motor inertia moment

From the above, the HF-KP23 (200W) is temporarily selected.

(8) Acceleration and deceleration torques

Torque required for servo motor during acceleration

$$T_{Ma} = \frac{(J_L/\eta + J_M) \cdot N_0}{9.55 \cdot 10^4 \cdot T_{psa}} + T_L = 1.85 [\text{N} \cdot \text{m}]$$

Torque required for servo motor during deceleration

$$T_{Md} = \frac{-(J_L/\eta + J_M) \cdot N_0}{9.55 \cdot 10^4 \cdot T_{psd}} + T_L = -0.86 [\text{N} \cdot \text{m}]$$

The torque required for the servo motor during deceleration must be lower than the servo motor's maximum torque.



## 5. CALCULATION METHODS FOR DESIGNING

(9) Continuous effective load torque

$$T_{rms} = \sqrt{\frac{T_{Ma}^2 \cdot t_{psa} + T_L^2 \cdot t_c + T_{Md}^2 \cdot t_{psd}}{t_f}} = 0.41 [\text{N} \cdot \text{m}]$$

The continuous effective load torque must be lower than the servo motor's rated torque.

(10) Torque pattern

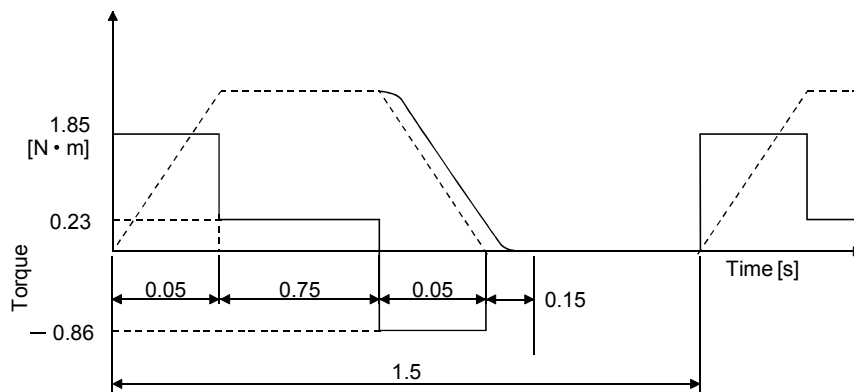

(11) Selection results

The HF-KP23 servo motor and MR-J3-20A servo amplifier are selected.

(a) Electronic gear setting

$$CMX = 32768$$

$$CDV = 125$$

(b) During rapid feed

$$\text{Servo motor speed} \quad N_0 = 3000 [\text{r}/\text{min}]$$

(c) Acceleration/deceleration time constant

$$t_{psa} = t_{psd} = 0.05[\text{s}]$$

## 5. CALCULATION METHODS FOR DESIGNING

### 5.10 Coasting distance of electromagnetic brake

At an emergency stop, the servo motor with an electromagnetic brake stops in the pattern shown in the following diagram. Here, the maximum coasting distance (during fast feed),  $L_{max}$ , will be the area shown with the diagonal line in the figure and can be calculated approximately with Equation 5.30. The effect of the load torque is greater near the stopping area. When the load torque is large, the servo motor will stop faster than the value obtained in the equation.

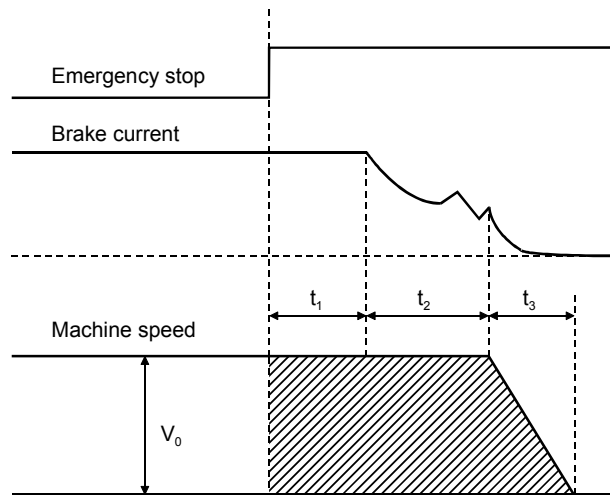

$$L_{max} = \frac{V_0}{60} \cdot \left( t_1 + t_2 + \frac{t_3}{2} \right) \dots \dots \dots (5.30)$$

Where,

- $L_{max}$  : Maximum coasting distance [mm]
- $V_0$ : Machine's fast feed speed [mm/min]
- $t_1$ : Delay time of control section [s]
- $t_2$ : Braking delay time of brake (Note) [s]
- $t_3$ : Braking time [s]

$$t_3 = \frac{(J_L + J_M) \cdot N_0}{9.55 \cdot 10^4 \cdot (T_L + 0.8T_B)}$$

- $J_L$  : Load inertia moment converted into equivalent value on servo motor shaft [ $\times 10^{-4} \text{kg} \cdot \text{m}^2$ ]
- $J_M$  : Servo motor's rotor inertia moment [ $\times 10^{-4} \text{kg} \cdot \text{m}^2$ ]
- $N_0$  : Servo motor speed during fast feed [r/min]
- $T_L$  : Load torque converted into equivalent value on servo motor shaft [ $\text{N} \cdot \text{m}$ ]
- $T_B$  : Brake static friction torque (Note) [ $\text{N} \cdot \text{m}$ ]

Note.  $t_2$  and  $T_B$  are Refer to the chapter of Servo Motor Series.  $J_L$  is the machine's inertia moment at the servo motor shaft.

### 5.11 Expression for calculating the electromagnetic brake workload

Calculate the brake workload  $E_b$  [J] at an emergency stop with the following expression.

$$E_b = \frac{(J_M + J_L) \cdot N^2}{182} \cdot 10^{-4}$$

- $N$ : Servo motor speed [r/min]
- $J_M$ : Servo motor's rotor inertia moment [ $\times 10^{-4} \text{kg} \cdot \text{m}^2$ ]
- $J_L$ : Load inertia moment converted into equivalent value on servo motor shaft [ $\times 10^{-4} \text{kg} \cdot \text{m}^2$ ]



# 6. HF-MP SERIES · HF-KP SERIES

## 6. HF-MP SERIES · HF-KP SERIES

This chapter provides information on the servo motor specifications and characteristics. When using the HF-MP series · HF-KP series servo motor, always read the Safety Instructions in the beginning of this manual and chapters 1 to 4, in addition to this chapter.

### 6.1 Model name make up

The following describes what each block of a model name indicates. Note that not all the combinations of the symbols exist.

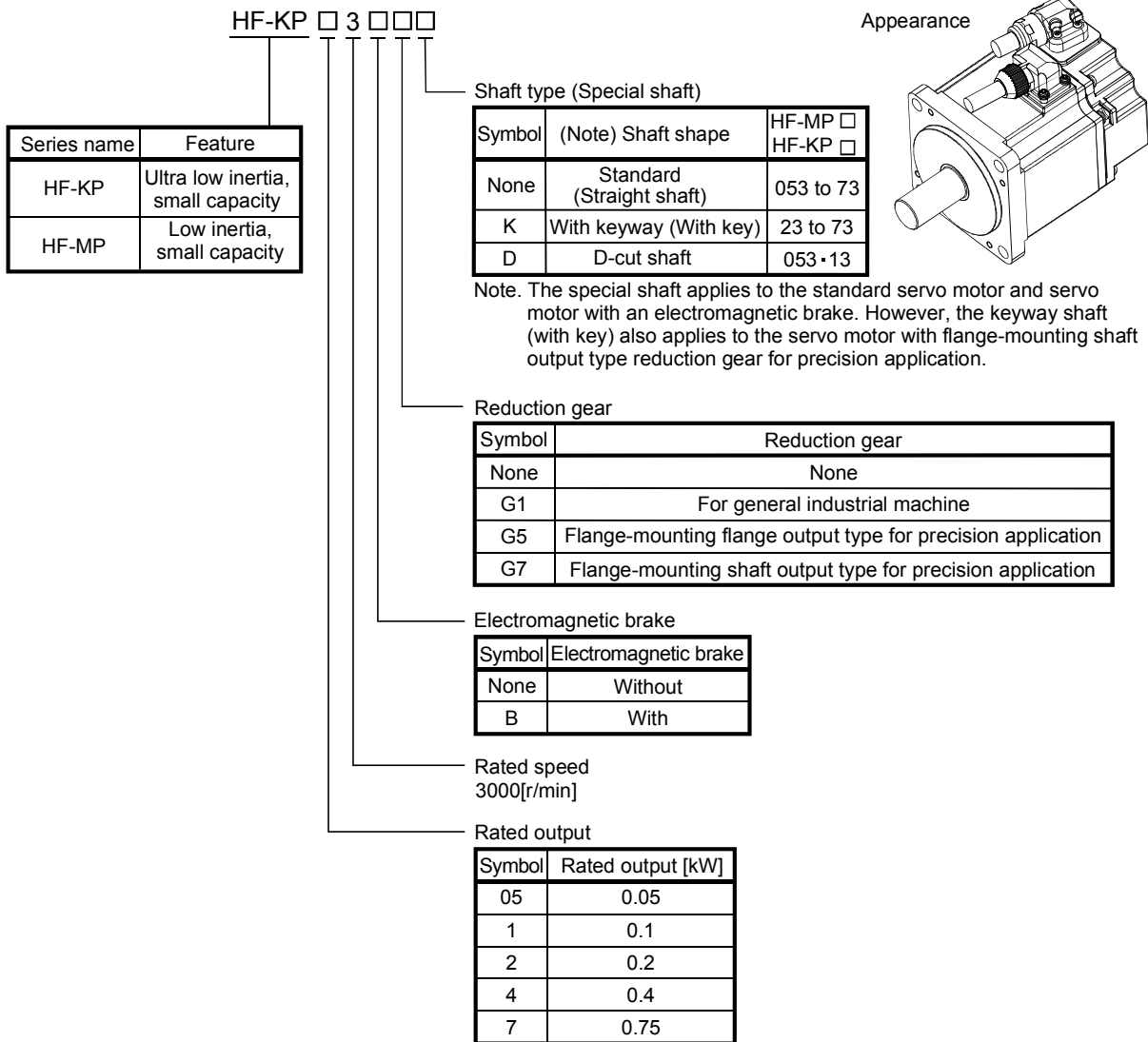

## 6. HF-MP SERIES · HF-KP SERIES

### 6.2 Standard specifications

#### 6.2.1 Standard specifications list

Item		Servo motor	HF-MP series (Ultra-low inertia * small capacity)					HF-KP series (Low inertia * small capacity)				
			053	13	23	43	73	053	13	23	43	73
Applicable servo amplifier/drive unit	MR-J3-□A/B/B-RJ006/T		10	20	40	70	10	20	40	70		
	MR-J3-□A1/B1/B1-RJ006/T1		10	20	40	70	10	20	40	70		
Continuous running duty (Note 1)	Rated output	[kW]	0.05	0.1	0.2	0.4	0.75	0.05	0.1	0.2	0.4	0.75
		Rated torque	[N · m]	0.16	0.32	0.64	1.3	2.4	0.16	0.32	0.64	1.3
			[oz · in]	22.7	45.3	90.6	184	340	22.7	45.3	90.6	184
Rated speed (Note 1)		[r/min]	3000					3000				
Maximum speed (Note 10)		[r/min]	6000					6000				
Instantaneous permissible speed		[r/min]	6900					6900				
Maximum torque Values in parentheses are at the maximum torque of 350% (note 11)		[N · m]	0.48	0.95	1.9	3.8	7.2	0.48 (0.56)	0.95 (1.11)	1.9 (2.23)	3.8 (4.46)	7.2 (8.36)
		[oz · in]	68.0	135	269	538	1020	68.0 (79.3)	135 (157)	269 (316)	538 (632)	1020 (1180)
Power rate at continuous rated torque		[kW/s]	13.3	31.7	46.1	111.6	95.5	4.87	11.5	16.9	38.6	39.9
Inertia moment (Note 3)	J	[ $\times 10^{-4}$ kg · m <sup>2</sup> ]	0.019	0.032	0.088	0.15	0.60	0.052	0.088	0.24	0.42	1.43
	WK <sup>2</sup>	[oz · in <sup>2</sup> ]	0.104	0.175	0.481	0.82	3.28	0.284	0.481	1.31	2.30	7.82
Recommended ratio of load inertia moment to servo motor shaft inertia moment (Note 2, 10)			30 times or less					15 times or less	24 times or less	22 times or less	15 times or less	
Power supply capacity			Refer to "Power supply equipment capacity and generated loss of servo amplifiers" in Servo Amplifier Instruction Manual.									
Rated current		[A]	1.1	0.9	1.6	2.7	5.6	0.9	0.8	1.4	2.7	5.2
Maximum current Values in parentheses are at the maximum torque of 350% (note 11)		[A]	3.2	2.8	5.0	8.6	16.7	2.7 (3.1)	2.4 (2.8)	4.2 (4.9)	8.1 (9.5)	15.6 (18.2)
Speed/position detector			Encoder common to absolute position and incremental detection systems (Resolution per servo motor 1 rotation: 262144pulse/rev)									
Accessory												
Insulation class			130(B)									
Structure			Totally - enclosed, natural-cooling (IP rating: IP65 (Note 4, 9))									
Environmental conditions (Note 5)	Ambient temperature	Operation	[°C]	0 to 40 (non-freezing)								
			[°F]	32 to 104 (non-freezing)								
		Storage	[°C]	-15 to 70 (non-freezing)								
			[°F]	5 to 158 (non-freezing)								
	Ambient humidity	Operation	80%RH or less (non-condensing)									
		Storage	90%RH or less (non-condensing)									
	Ambience	Indoors (no direct sunlight) Free from corrosive gas, flammable gas, oil mist, dust and dirt.										
	Altitude	Max.1000m above sea level										
Vibration resistance (Note 6)		[m/s <sup>2</sup> ]	X, Y: 49									
Vibration rank (Note 7)			V10									
Permissible load for the shaft (Note 8, 10)	L	[mm]	25	30	40	25	30	40				
		Radial	[N]	88	245	392	88	245	392			
	[lb]		19.8	55.1	88.1	19.8	55.1	88.1				
	Thrust	[N]	59	98	147	59	98	147				
[lb]		13.3	22.0	33.0	13.3	22.0	33.0					
Mass (Note 3)		[kg]	0.35	0.56	0.94	1.5	2.9	0.35	0.56	0.94	1.5	2.9
		[lb]	0.77	1.24	2.07	3.31	6.39	0.77	1.24	2.07	3.31	6.39

Note 1. When the power supply voltage drops, the out.

2. If the load inertia moment ratio exceeds the indicated value, please consult us.

## 6. HF-MP SERIES · HF-KP SERIES

3. Refer to the outline dimension drawing for the servo motors with an electromagnetic brake and with a reduction gear.
4. Except for the shaft-through portion.
5. In the environment where the servo motor is exposed to oil mist, oil and/or water, the servo motor of the standard specifications may not be usable. Contact your local sales office.
6. The vibration direction is as shown in the figure. The value is the one at the part that indicates the maximum value (normally the opposite-to-load side bracket). When the servo motor stops, fretting is likely to occur at the bearing. Therefore, suppress the vibration to about half of the permissible value. Note that this does not apply to the servo motor with a reduction gear.

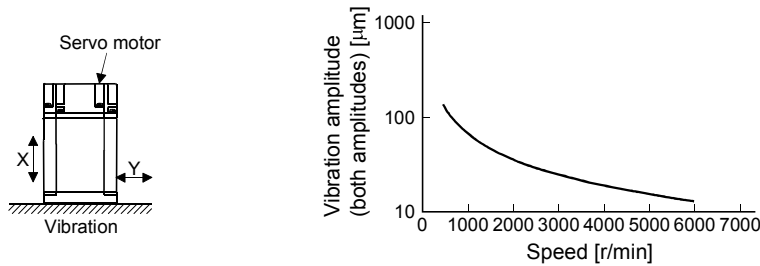

7. V10 indicates that the amplitude of a single servo motor is 10µm or less. The following figure shows the servo motor installation position for measurement and the measuring position.

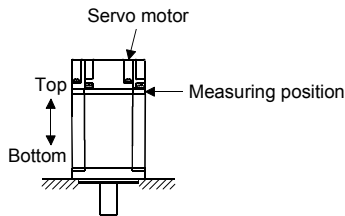

8. For the symbols in the table, refer to the following diagram: Do not subject the shaft to load greater than this value. The values in the table assume that the loads work singly.

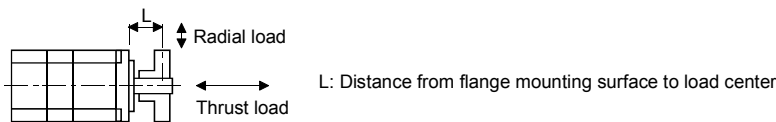

9. For the servo motor with a reduction gear, the reduction gear area is IP44-equivalent.
10. Refer to section 6.5 for the servo motor with a reduction gear.
11. The maximum torque of 350% is enabled when HF-KP servo motor (excluding the motors with a reduction gear) is used with following combinations. The maximum torque of the HF-KP servo motor (excluding motors with a reduction gear) can be increased from 300% to 350% of the rated torque by setting servo amplifier's parameter.

	Series or type	Date of manufacture	Servo amplifier software version
Servo motor	HF-KP (except reducer-mounted motors)	June 2009 or later	
Servo amplifier	MR-J3-A(1)	January 2010 or later	C6 or later
	MR-J3-B(1)/B(1)-RJ006/BS(1)	August 2009 or later	C4 or later
	MR-J3-T(1)	April 2010 or later	A8 or later

## 6. HF-MP SERIES · HF-KP SERIES

### 6.2.2 Torque characteristics

POINT
<ul style="list-style-type: none"> <li>For machines which produce unbalance torque, e.g. vertical lift applications, it is recommended to use the servo motor so that the unbalance torque will be within 70% of the rated torque.</li> </ul>

When the power input of the servo amplifier are 3-phase 200VAC or 1-phase 230VAC, the torque characteristic is indicated by the heavy line.

For the 1-phase 200VAC power supply, part of the torque characteristic is indicated by the thin line. For the 1-phase 100VAC power supply, part of the torque characteristic is indicated by the broken line.

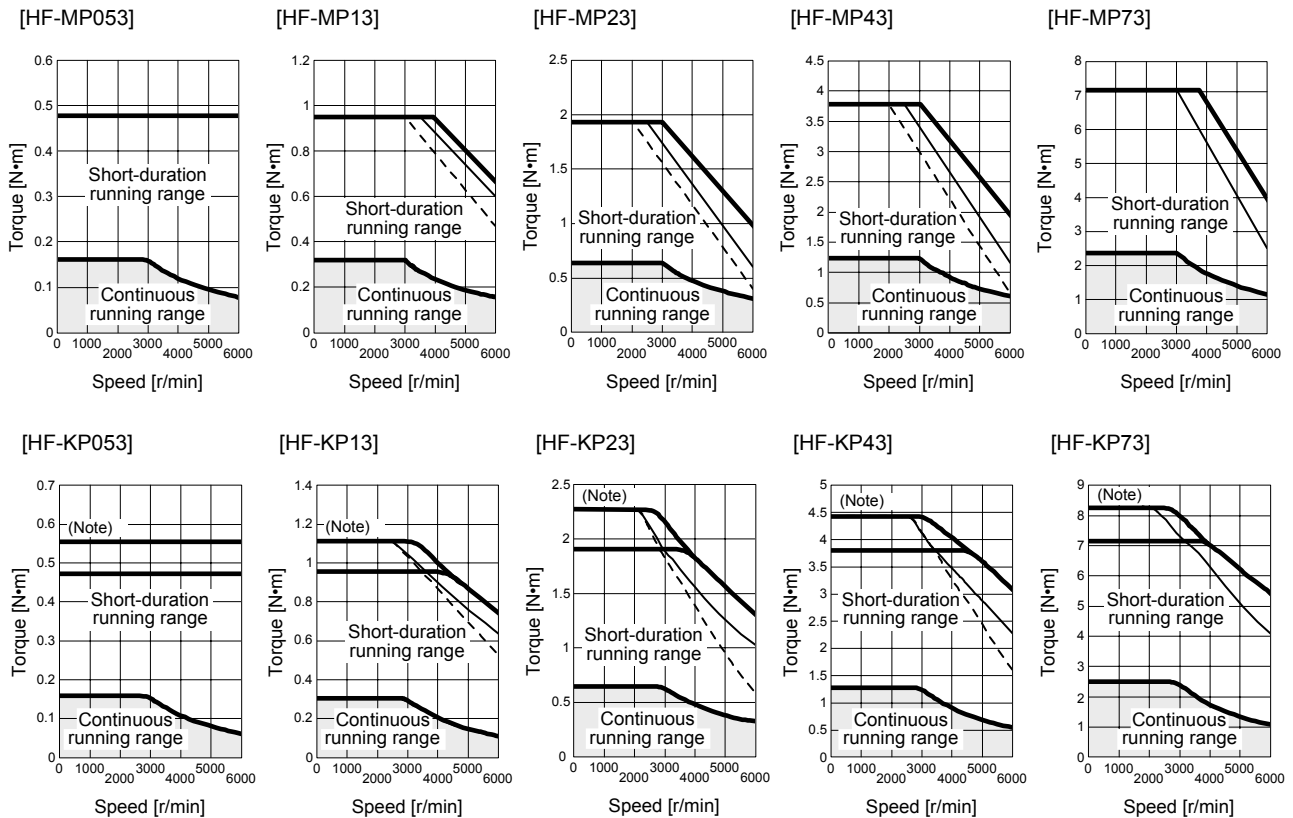

Note. Value at the maximum torque 350%.

## 6. HF-MP SERIES · HF-KP SERIES

### 6.3 Electromagnetic brake



#### CAUTION

- The electromagnetic brake is provided to prevent a drop at a power failure or servo alarm occurrence during vertical drive or to hold a shaft at a stop. Do not use it for normal braking (including braking at servo lock).
- Before performing the operation, be sure to confirm that the electromagnetic brake operates properly.
- The operation time of the electromagnetic brake differs depending on the power supply circuit you use. Be sure to check the operation delay time with a real machine.

The characteristics of the electromagnetic brake provided for the servo motor with an electromagnetic brake are indicated below.

Item	Servo motor	HF-MP series · HF-KP series				
		053B	13B	23B	43B	73B
Type (Note 1)		Spring-loaded safety brake				
Rated voltage (Note 4)		24V <sup>0</sup> <sub>-10%</sub> DC				
Capacity	[W] at 20°C (68°F)	6.3		7.9		10
Coil resistance (Note 6)	[Ω]	91.0		73.0		57.0
Inductance (Note 6)	[H]	0.15		0.18		0.13
Brake static friction torque	[N · m]	0.32		1.3		2.4
	[oz · in]	45.3		184		340
Release delay time (Note 2)	[s]	0.03		0.03		0.04
Braking delay time (Note 2)	[s] DC off	0.01		0.02		0.02
Permissible braking work	Per braking [J]	5.6		22		64
	Per hour [J]	56		220		640
Brake looseness at servo motor shaft (Note 5)	[degrees]	2.5		1.2		0.9
Brake life (Note 3)	Number of braking cycles [times]	20000		20000		20000
	Work per braking [J]	5.6		22		64
Selection example of surge absorbers to be used (Note 7, 8)	For the suppressed voltage 125V	TND20V-680KB				
	For the suppressed voltage 350V	TND10V-221KB				

Note 1. There is no manual release mechanism. When it is necessary to hand-turn the servo motor shaft for machine centering, etc., use a separate 24VDC power supply to release the brake electrically.

2. The value for initial ON gap at 20°C (68°F).

3. The brake gap will increase as the brake lining wears, but the gap is not adjustable. The brake life indicated is the number of braking cycles after which adjustment will be required.

4. Always prepare a power supply exclusively used for the electromagnetic brake.

5. The above values are typical initial values and not guaranteed values.

6. These values are measured values and not guaranteed values.

7. Select the electromagnetic brake control relay properly, considering the characteristics of the electromagnetic brake and surge absorber.

8. Manufactured by Nippon Chemi-Con Corporation.



## 6. HF-MP SERIES · HF-KP SERIES

### 6.4 Servo motors with special shafts

The servo motors with special shafts indicated by the symbols (K · D) in the table are available. K and D are the symbols attached to the servo motor model names.

Refer to section 6.5.2 (4) for geared servo motors with special shaft.

Servo motor	Shaft shape	
	Keyway shaft (with key)	D cut shaft
HF-MP053(B)□ · 13(B)□ HF-KP053(B)□ · 13(B)□		D
HF-MP23(B)□ to 73(B)□ HF-KP23(B)□ to 73(B)□	K	

#### 6.4.1 Keyway shaft (with key)

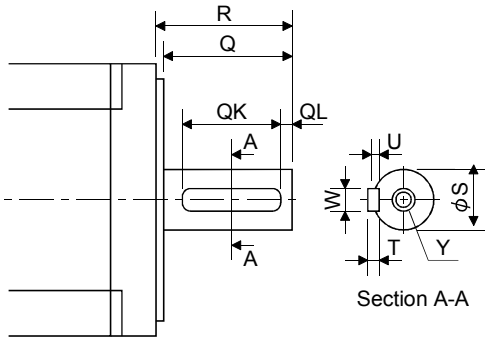

Variable dimension table

[Unit: mm]

Servo motor	Variable dimensions								
	S	R	Q	W	QK	QL	U	T	Y
HF- MP23(B)K · 43(B)K HF- KP23(B)K · 43(B)K	14h6	30	27	5	20	3	3	5	M4 Depth 15
HF- MP73(B)K HF- KP73(B)K	19h6	40	37	6	25	5	3.5	6	M5 Depth 20

#### 6.4.2 D cut shaft

[Unit: mm]

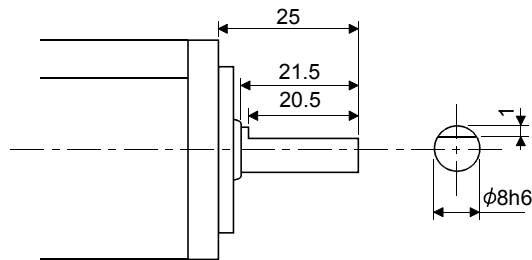

## 6. HF-MP SERIES · HF-KP SERIES

### 6.5 Servo motors with a reduction gear



**CAUTION**

- The servo motor with a reduction gear must be installed in the specified direction. Otherwise, it can leak oil, leading to a fire or fault.
- For the servo motor with a reduction gear, transport it in the same status as in the installation method. Tipping it over can cause oil leakage.

Servo motors are available with a reduction gear designed for general industrial machines compliant and precision applications compliant.

Servo motors with an electromagnetic brake are also available.

#### 6.5.1 For general industrial machines compliant (G1)

##### (1) Manufacturing range

The following table indicates the reduction ratios and actual reduction ratios of the servo motors with a reduction gear for general industrial machines compliant. The servo motors with a reduction gear of the following reduction ratios are available.

Servo motor	Nominal reduction ratio	Actual reduction ratio
HF-MP053(B)G1 HF-KP053(B)G1	1/5	9/44
	1/12	49/576
	1/20	25/484
HF-MP13(B)G1 HF-KP13(B)G1	1/5	9/44
	1/12	49/576
	1/20	25/484
HF-MP23(B)G1 HF-KP23(B)G1	1/5	19/96
	1/12	25/288
	1/20	253/5000
HF-MP43(B)G1 HF-KP43(B)G1	1/5	19/96
	1/12	25/288
	1/20	253/5000
HF-MP73(B)G1 HF-KP73(B)G1	1/5	1/5
	1/12	525/6048
	1/20	625/12544

## 6. HF-MP SERIES · HF-KP SERIES

### (2) Specifications

Item		Description				
Servo motor		HF-KP□(B)G1/HF-MP□(B)G1				
Mounting method		Flange mounting				
Mounting direction		In any directions				
Lubrication method		Grease lubrication (Already packed) (Note 1)				
Packed with	50W · 100W	200W · 400W 1/12, 1/20	750W 1/12	200W · 400W	750W 1/5, 1/20	
	Mobilplex 46 Exxon Mobil	Molynoc AP2 JX Nippon Oil & Energy		Mobil Grease SP Exxon Mobil		
Output shaft rotating direction		Same as the servo motor output shaft direction.				
With an electromagnetic brake		Available				
Backlash		60 minutes or less at reduction gear output shaft				
Permissible load inertia moment ratio (when converting into the servo motor shaft) (Note 2)		HF-KP When 50W · 100W · 750W · used: 5 times or less When 200W · 400W used: 7 times or less HF-MP: 25 times or less				
Permissible speed (at servo motor shaft)		4500 r/min				
IP rating (reduction gear area)		IP44 equivalent				
Reduction gear efficiency (Note 3)		45 to 75%				

Note 1. Already packed with grease.

2. If the above indicated value is exceeded, please consult your local sales office.

3. The reduction gear efficiency differs depending on the reduction ratio.

Also, it changes depending on the use conditions such as the output torque, speed and rotation, temperature, etc. The numerical value in the table is a typical value in the rated torque, rated speed and rotation and typical temperature, and not a guaranteed value.

### (3) Permissible loads of servo motor shaft

The permissible radial load in the table is the value measured at the center of the reduction gear output shaft.

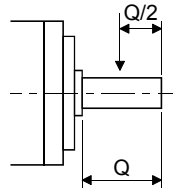

Q: Length of axis  
(Refer to section 6.8.3, 6.8.4)

Servo motor	Reduction ratio	Permissible load (Note)			
		Permissible radial load		Permissible thrust load	
		[N]	[lb]	[N]	[lb]
HF-MP053(B)G1 HF-KP053(B)G1	1/5	150	33.7	200	45.0
	1/12	240	54.0	320	71.9
	1/20	370	83.2	450	101
HF-MP13(B)G1 HF-KP13(B)G1	1/5	150	33.7	200	45.0
	1/12	240	54.0	320	71.9
	1/20	370	83.2	450	101
HF-MP23(B)G1 HF-KP23(B)G1	1/5	330	74.2	350	78.7
	1/12	710	160	720	162
	1/20	780	175	780	175
HF-MP43(B)G1 HF-KP43(B)G1	1/5	330	74.2	350	78.7
	1/12	710	160	720	162
	1/20	760	171	760	171
HF-MP73(B)G1 HF-KP73(B)G1	1/5	430	96.7	430	96.7
	1/12	620	139	620	139
	1/20	970	218	960	216

Note. The load above this value should not be applied to the shaft.

The value in the table assumes that the load is applied independently.

## 6. HF-MP SERIES · HF-KP SERIES

### 6.5.2 For precision applications compliant (G5/G7)

#### (1) Manufacturing range

The symbols (14A, 20A, 32A) in the following table indicate the model numbers of the reduction gears assembled to the servo motors.

Servo motors with a reduction gear having the indicated reduction gear model numbers are available.

The reduction gear model number indicates □□□ of the reduction number model name HPG-□□□-05...

Servo motor		Reduction ratio				
		1/5	1/11	1/21	1/33	1/45
HF-MP053(B)G5	HF-KP053(B)G5					
HF-MP053(B)G7	HF-KP053(B)G7					
HF-MP13(B)G5	HF-KP13(B)G5		14A			
HF-MP13(B)G7	HF-KP13(B)G7					
HF-MP23(B)G5	HF-KP23(B)G5			20A		
HF-MP23(B)G7	HF-KP23(B)G7					
HF-MP43(B)G5	HF-KP43(B)G5					
HF-MP43(B)G7	HF-KP43(B)G7					
HF-MP73(B)G5	HF-KP73(B)G5				32A	
HF-MP73(B)G7	HF-KP73(B)G7					

#### (2) Specifications

Item		Description	
Servo motor		HF-MP□(B)G5 HF-MP□(B)G7	HF-KP□(B)G5 HF-KP□(B)G7
Mounting method		Flange mounting	
Mounting direction		In any directions	
Lubrication method		Grease lubrication (Already packed) (Note 1)	
Packed with		Harmonic grease SK-2 (Harmonic Drive Systems)	
Output shaft rotating direction		Same as the servo motor output shaft direction.	
With an electromagnetic brake		Available	
Backlash		3 minutes or less at reduction gear output shaft	
Permissible load inertia moment ratio (when converting into the servo motor shaft) (Note 2)		25 times or less	50, 100 or 750W: 10 times or less 200 or 400W: 14 times or less
Permissible speed (at servo motor shaft)		6000r/min	
IP rating (reduction gear area)		IP44 equivalent	
Reduction gear efficiency (Note 3)		58 to 87% (Note 4)	

Note 1. Already packed with grease.

2. If the above indicated value is exceeded, please consult your local sales office.

3. The reduction gear efficiency differs depending on the reduction ratio.

Also, it changes depending on the use conditions such as the output torque, speed and rotation, temperature, etc. The numerical value in the table is a typical value in the rated torque, rated speed and rotation and typical temperature, and not a guaranteed value.

4. The reduction gear efficiency of the HF-MP053 · HF-KP053 is 22 to 41%.

## 6. HF-MP SERIES · HF-KP SERIES

### (3) Permissible loads of servo motor shaft

The radial load point of a precision reduction gear is as shown below.

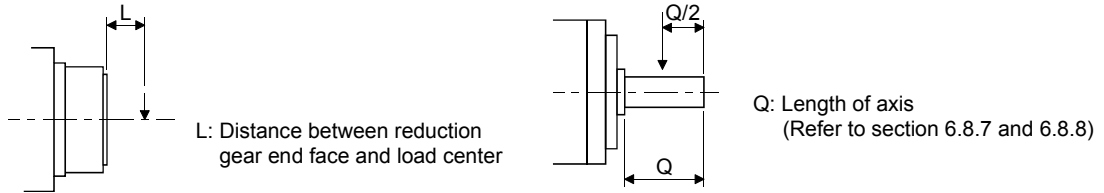

Flange-mounting flange output type for precision application compliant (G5)

Flange-mounting shaft output type for precision application compliant (G7)

Servo motor	Reduction ratio	Radio load point L [mm]	Permissible load (Note)			
			Permissible radial load		Permissible thrust load	
			[N]	[lb]	[N]	[lb]
HF-MP053(B)G5 HF-KP053(B)G5 HF-MP053(B)G7 HF-KP053(B)G7	1/5	23	177	39.8	706	159
	1/11	23	224	50.4	895	201
	1/21	23	272	61.1	1087	224
	1/33	23	311	69.9	1244	280
	1/45	23	342	76.9	1366	307
HF-MP13(B)G5 HF-KP13(B)G5 HF-MP13(B)G7 HF-KP13(B)G7	1/5	23	177	39.8	706	159
	1/11	23	224	50.4	895	201
	1/21	23	272	61.1	1087	224
	1/33	32	733	165	2581	570
	1/45	32	804	181	2833	637
HF-MP23(B)G5 HF-KP23(B)G5 HF-MP23(B)G7 HF-KP23(B)G7	1/5	23	177	39.8	706	159
	1/11	23	224	50.4	895	201
	1/21	32	640	144	2254	507
	1/33	32	733	165	2581	570
	1/45	32	804	181	2833	637
HF-MP43(B)G5 HF-KP43(B)G5 HF-MP43(B)G7 HF-KP43(B)G7	1/5	23	177	39.8	706	159
	1/11	32	527	118	1856	4170
	1/21	32	640	309	2254	1230
	1/33	57	1252	281	4992	1120
	1/45	57	1374	309	5478	1230
HF-MP73(B)G5 HF-KP73(B)G5 HF-MP73(B)G7 HF-KP73(B)G7	1/5	32	416	93.5	1465	3290
	1/11	32	527	118	1856	4170
	1/21	57	1094	246	4359	9800
	1/33	57	1252	281	4992	1120
	1/45	57	1374	309	5478	1230

Note. The load above this value should not be applied to the shaft.

The value in the table assumes that the load is applied independently.

## 6. HF-MP SERIES · HF-KP SERIES

### (4) Special shaft servo motors

Servo motors with special shafts having keyway (with single pointed keys) are available for the flange-mounting shaft output type for precision applications compliant (G7).

[Unit: mm]

Servo motor	Reduction gear model number	Q	$\phi S$	W	T	QK	U	Y
HC-MP□(B)G7K HC-KP□(B)G7K	14A	28	16h7	5	5	25	3	M4 Depth 8
	20A	42	25h7	8	7	36	4	M6 Depth 12
	32A	82	40h7	12	8	70	5	M10 Depth 20

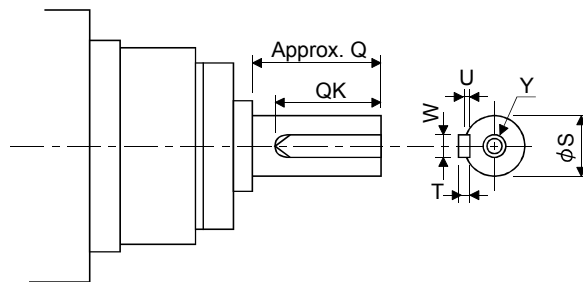

### 6.6 Wiring option

Connector sets to use in power supply connector or brake connector are available as option.

For details of each cable, cable and connector set to use in wiring to encoder, refer to the Servo Amplifier Instruction Manual for using.

Make sure to use the following power supply cable for conforming to the EN compliant.

Servo motor	Servo motor power cable	Electromagnetic brake cable
HF-MP HF-KP	MR-PWS1CBL□M-A1-L	MR-BKS1CBL□M-A1-L
	MR-PWS1CBL□M-A1-H	MR-BKS1CBL□M-A1-H
	MR-PWS1CBL□M-A2-L	MR-BKS1CBL□M-A2-L
	MR-PWS1CBL□M-A2-H	MR-BKS1CBL□M-A2-H
	MR-PWS2CBL03M-A1-L	MR-BKS2CBL03M-A1-L
	MR-PWS2CBL03M-A2-L	MR-BKS2CBL03M-A2-L

## 6. HF-MP SERIES · HF-KP SERIES

### 6.7 Connector installation

If the connector is not fixed securely, it may come off or may not produce a splash-proof effect during operation.

To achieve the IP rating IP65, pay attention to the following points and install the connectors.

(1) When screwing the connector, hold the connector still and gradually tighten the screws in a crisscross pattern.

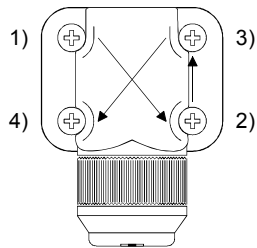

Tightening sequence  
1) → 2) → 3) → 4)

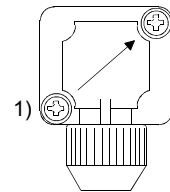

2) Tightening sequence  
1) → 2)

Connector for power supply, connector for encoder

Connector for brake

(2) Tighten the screws evenly.

Tightening torques are as indicated below.

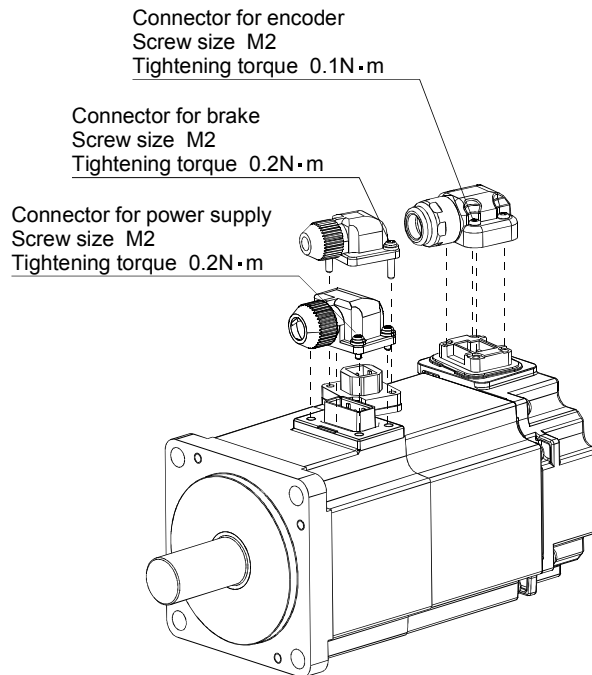

(3) The servo motor fitting part of each connector is provided with a splash-proof seal (O ring). When installing the connector, use care to prevent the seal (O ring) from dropping and being pinched. If the seal (O ring) has dropped or is pinched, a splash-proof effect is not produced.

## 6. HF-MP SERIES · HF-KP SERIES

### 6.8 Outline dimension drawings

The outer frame of the reduction gear is a material surface such as casting. Its actual dimensions may be 1 to 3mm larger than the drawing dimensions. Design the machine side with allowances.

When running the cables to the load side, take care to avoid interference with the machine. The dimensions without tolerances are reference dimensions.

Inertia moment on the table is the value calculated by converting the total value of inertia moment for servo motor, electromagnetic brake and decelerator with servo motor shaft.

#### 6.8.1 Standard (without an electromagnetic brake, without a reduction gear)

Model	Output [W]	Inertia moment J [ $\times 10^{-4} \text{kg} \cdot \text{m}^2$ ] (WK <sup>2</sup> [oz · in <sup>2</sup> ])	Mass [kg] ([lb])
HF-MP053	50	0.019 (0.104)	0.35 (0.77)
HF-KP053	50	0.052 (0.284)	0.35 (0.77)

[Unit: mm]

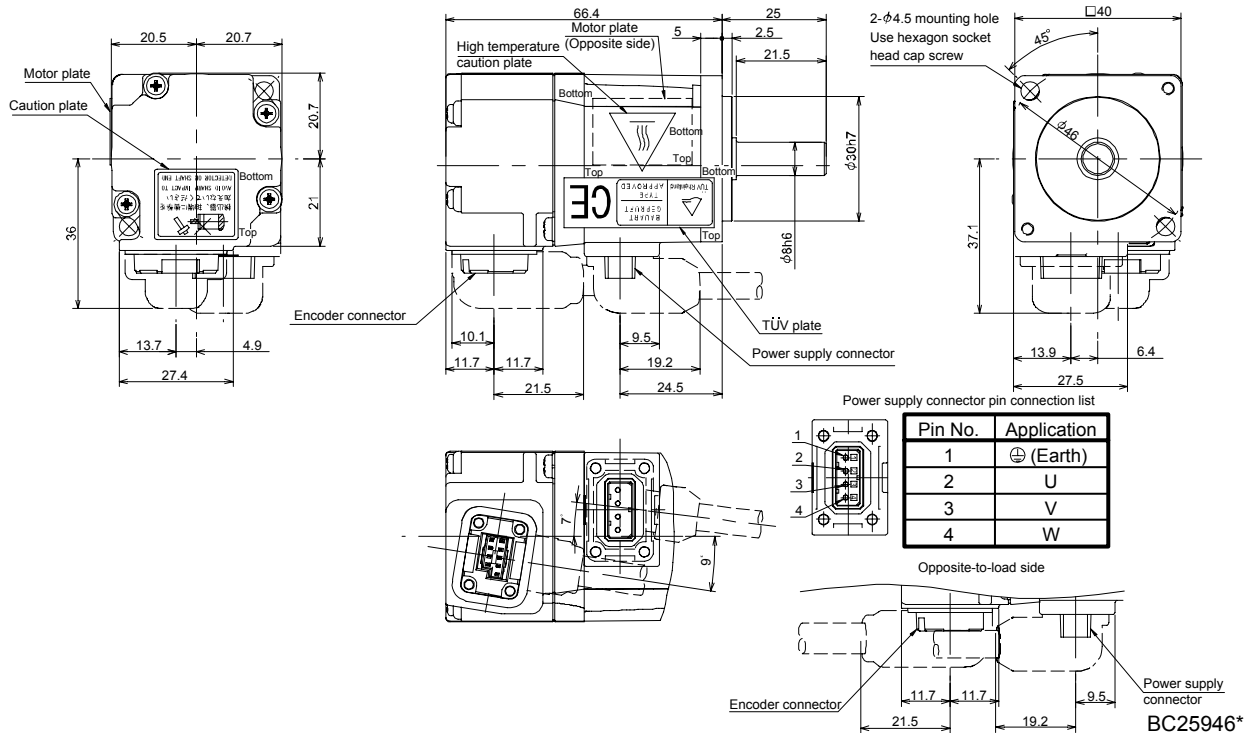



## 6. HF-MP SERIES · HF-KP SERIES

Model	Output [W]	Inertia moment J [ $\times 10^{-4}$ kg · m <sup>2</sup> ] (WK <sup>2</sup> [oz · in <sup>2</sup> ])	Mass [kg] (lb)
HF-MP13	100	0.032 (0.175)	0.56 (1.24)
HF-KP13	100	0.088 (0.481)	0.56 (1.24)

[Unit: mm]

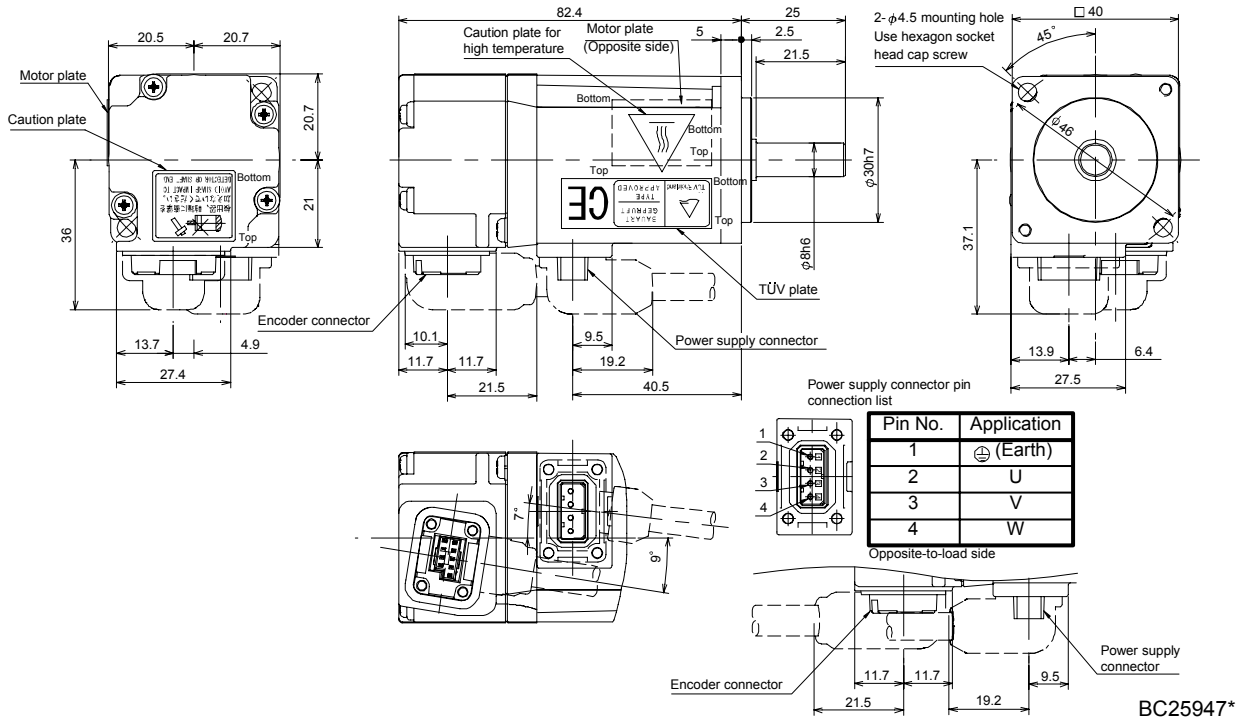

Model	Output [W]	Inertia moment J [ $\times 10^{-4}$ kg · m <sup>2</sup> ] (WK <sup>2</sup> [oz · in <sup>2</sup> ])	Mass [kg] (lb)
HF-MP23	200	0.088 (0.481)	0.94 (2.07)
HF-KP23	200	0.24 (1.31)	0.94 (2.07)

[Unit: mm]

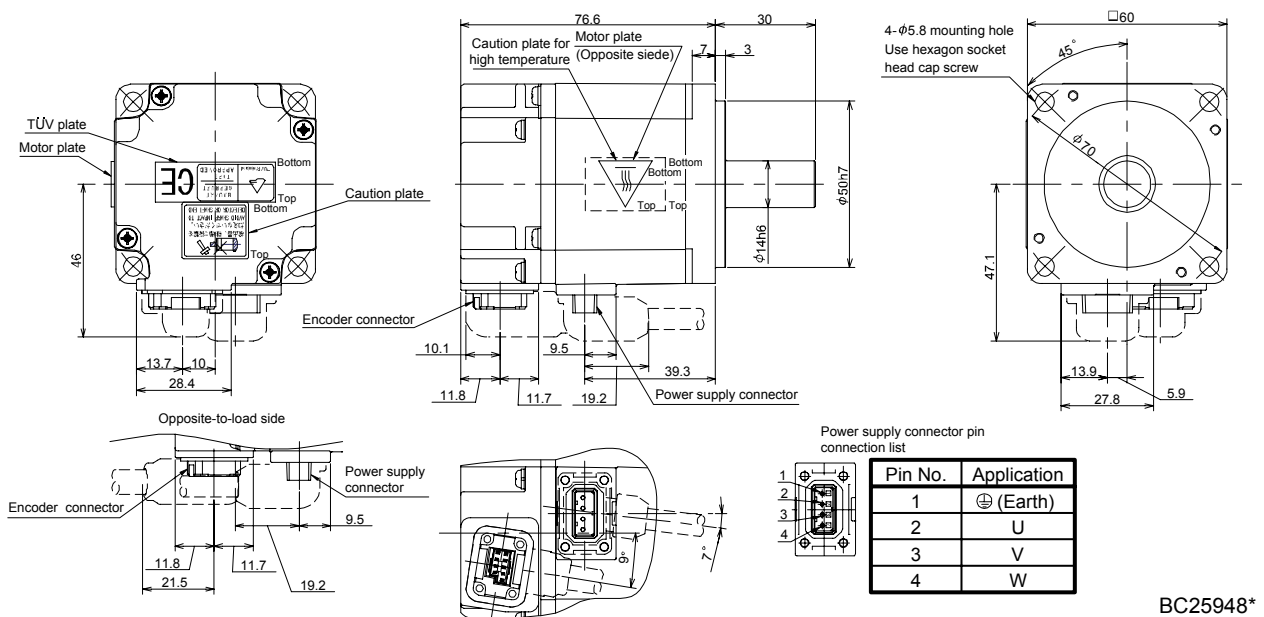

## 6. HF-MP SERIES • HF-KP SERIES

Model	Output [W]	Inertia moment J [ $\times 10^{-4} \text{kg} \cdot \text{m}^2$ ] ( $\text{WK}^2$ [oz · in <sup>2</sup> ])	Mass [kg] ([lb])
HF-MP43	400	0.15 (0.82)	1.5 (3.31)
HF-KP43	400	0.42 (2.30)	1.5 (3.31)

[Unit: mm]

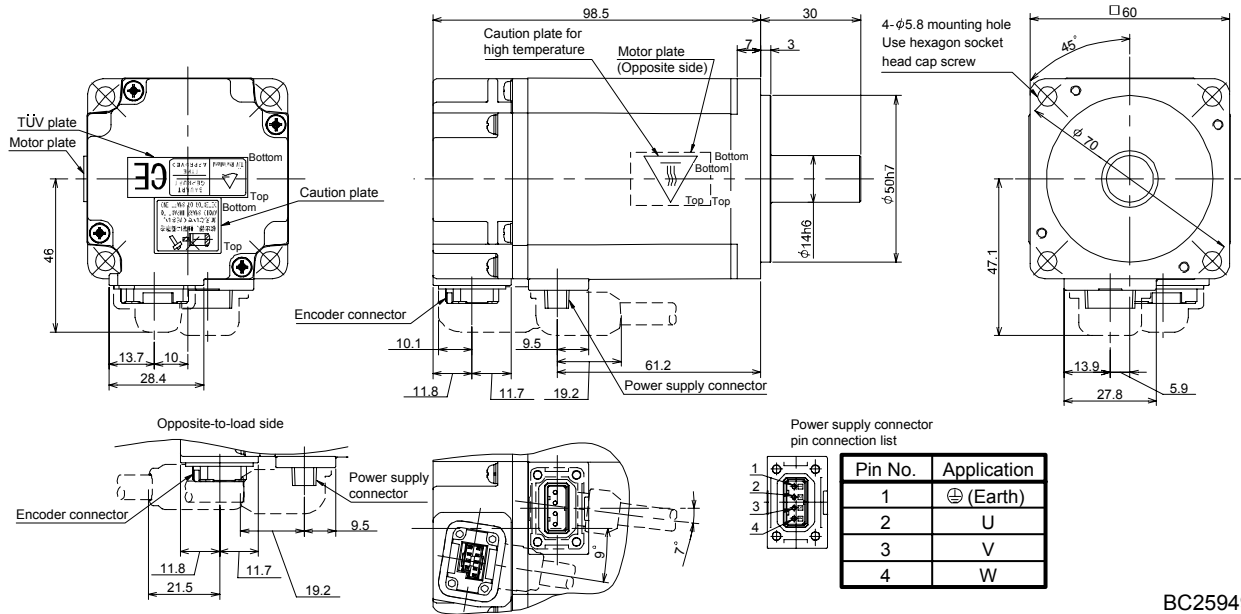

BC25949\*

Model	Output [W]	Inertia moment J [ $\times 10^{-4} \text{kg} \cdot \text{m}^2$ ] ( $\text{WK}^2$ [oz · in <sup>2</sup> ])	Mass [kg] ([lb])
HF-MP73	750	0.60 (3.28)	2.9 (6.39)
HF-KP73	750	1.43 (7.82)	2.9 (6.39)

[Unit: mm]

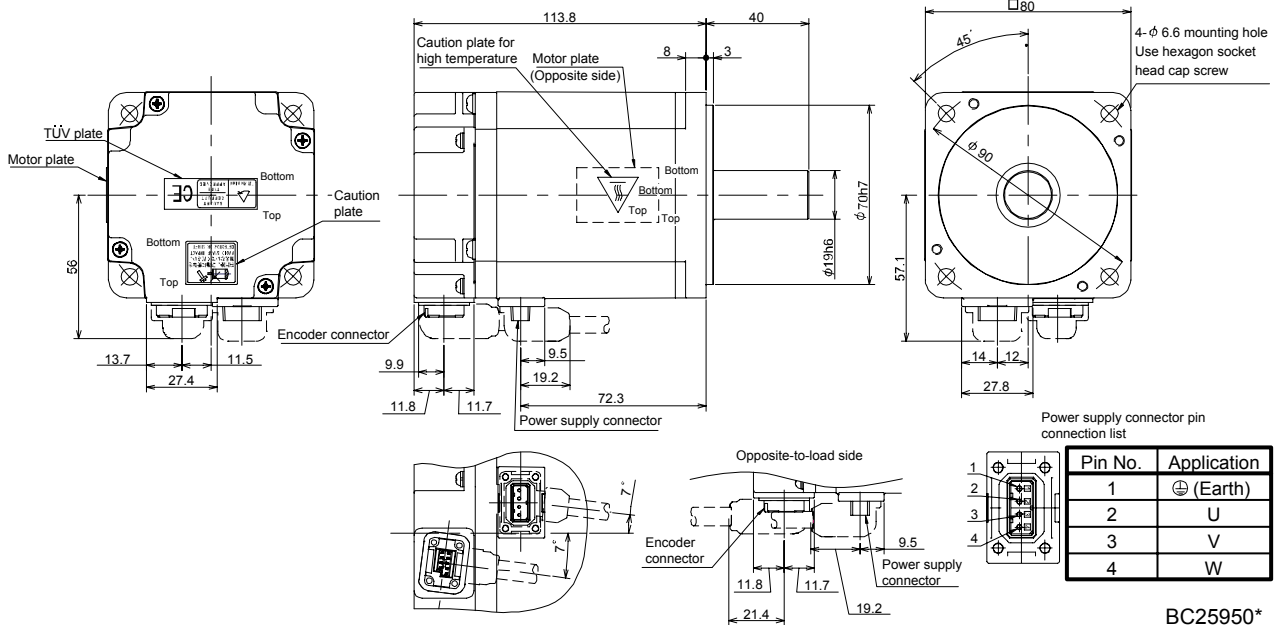

BC25950\*

# 6. HF-MP SERIES · HF-KP SERIES

## 6.8.2 With an electromagnetic brake

Model	Output [W]	Brake static friction torque [N · m] ([oz · in])	Inertia moment J [ $\times 10^{-4} \text{kg} \cdot \text{m}^2$ ] ( $\text{WK}^2$ [oz · in <sup>2</sup> ])	Mass [kg] ([lb])
HF-MP053B	50	0.32 (45.3)	0.025 (0.137)	0.65 (1.43)
HF-KP053B	50	0.32 (45.3)	0.054 (0.295)	0.65 (1.43)

[Unit: mm]

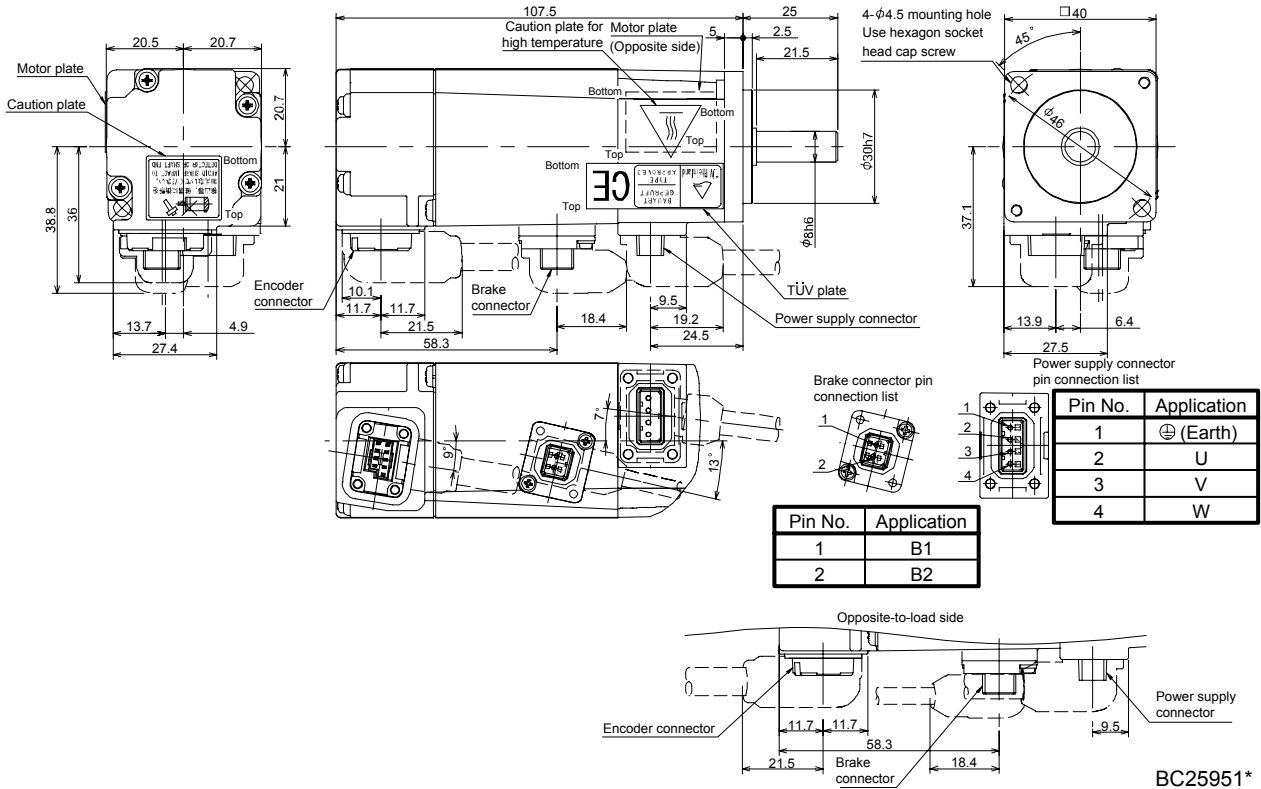

## 6. HF-MP SERIES · HF-KP SERIES

Model	Output [W]	Brake static friction torque [N · m] (oz · in)	Inertia moment J [ $\times 10^{-4}$ kg · m <sup>2</sup> ] (WK <sup>2</sup> [oz · in <sup>2</sup> ])	Mass [kg] ([lb])
HF-MP13B	100	0.32 (45.3)	0.039 (0.213)	0.86 (1.90)
HF-KP13B	100	0.32 (45.3)	0.090 (0.492)	0.86 (1.90)

[Unit: mm]

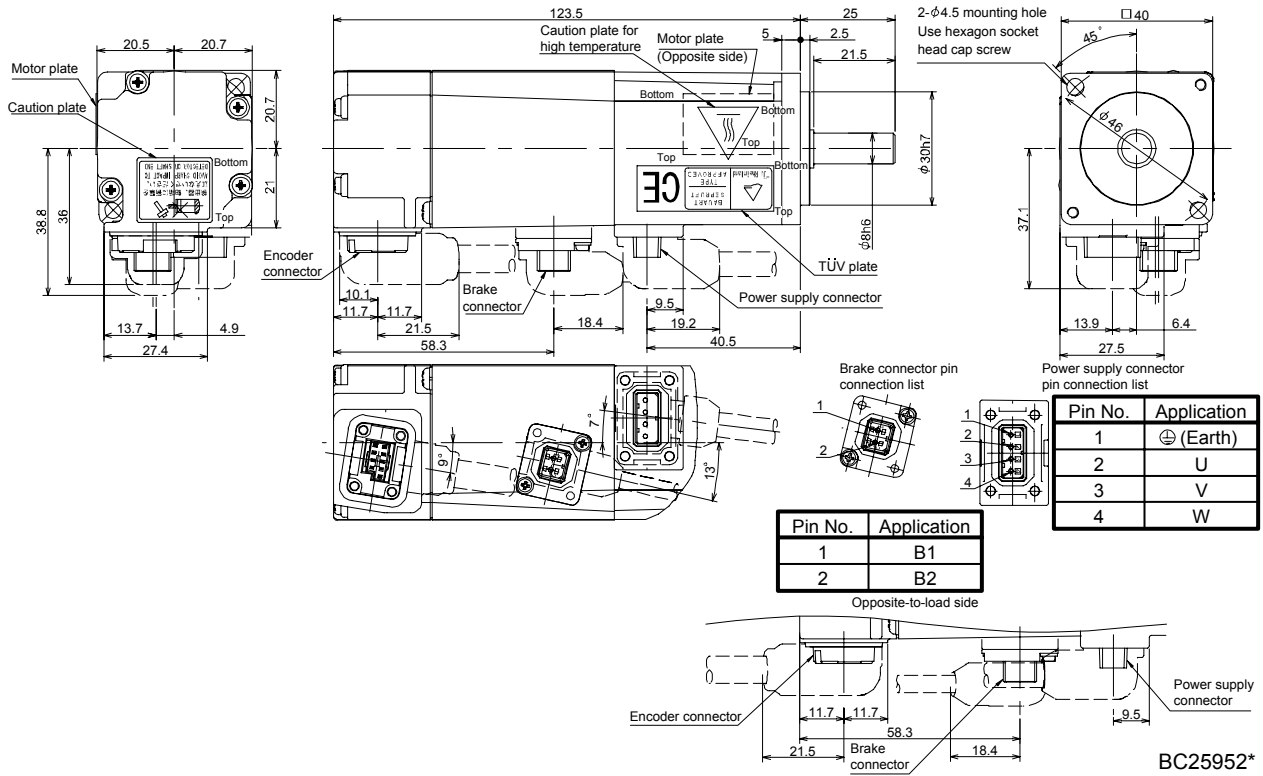

## 6. HF-MP SERIES · HF-KP SERIES

Model	Output [W]	Brake static friction torque [N · m] (oz · in)	Inertia moment J [ $\times 10^{-4}$ kg · m <sup>2</sup> ] (WK <sup>2</sup> [oz · in <sup>2</sup> ])	Mass [kg] (lb)
HF-MP23B	200	1.3 (184)	0.12 (0.656)	1.6(3.53)
HF-MP23B	200	1.3 (184)	0.31 (1.70)	1.6(3.53)

[Unit: mm]

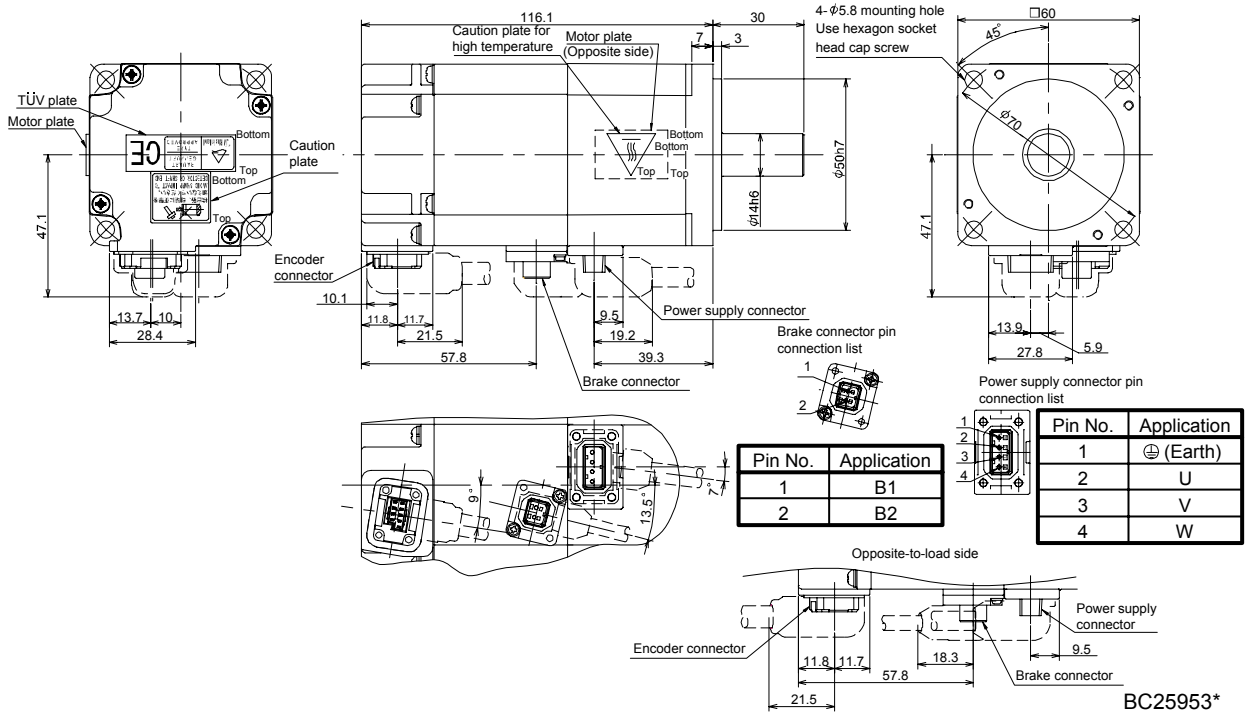

BC25953\*

## 6. HF-MP SERIES · HF-KP SERIES

Model	Output [W]	Brake static friction torque [N · m] (oz · in)	Inertia moment J [ $\times 10^{-4}$ kg · m <sup>2</sup> ] (WK <sup>2</sup> [oz · in <sup>2</sup> ])	Mass [kg] ([lb])
HF-MP43B	400	1.3 (184)	0.18 (0.984)	2.1 (4.63)
HF-MP43B	400	1.3 (184)	0.50 (2.73)	2.1 (4.63)

[Unit: mm]

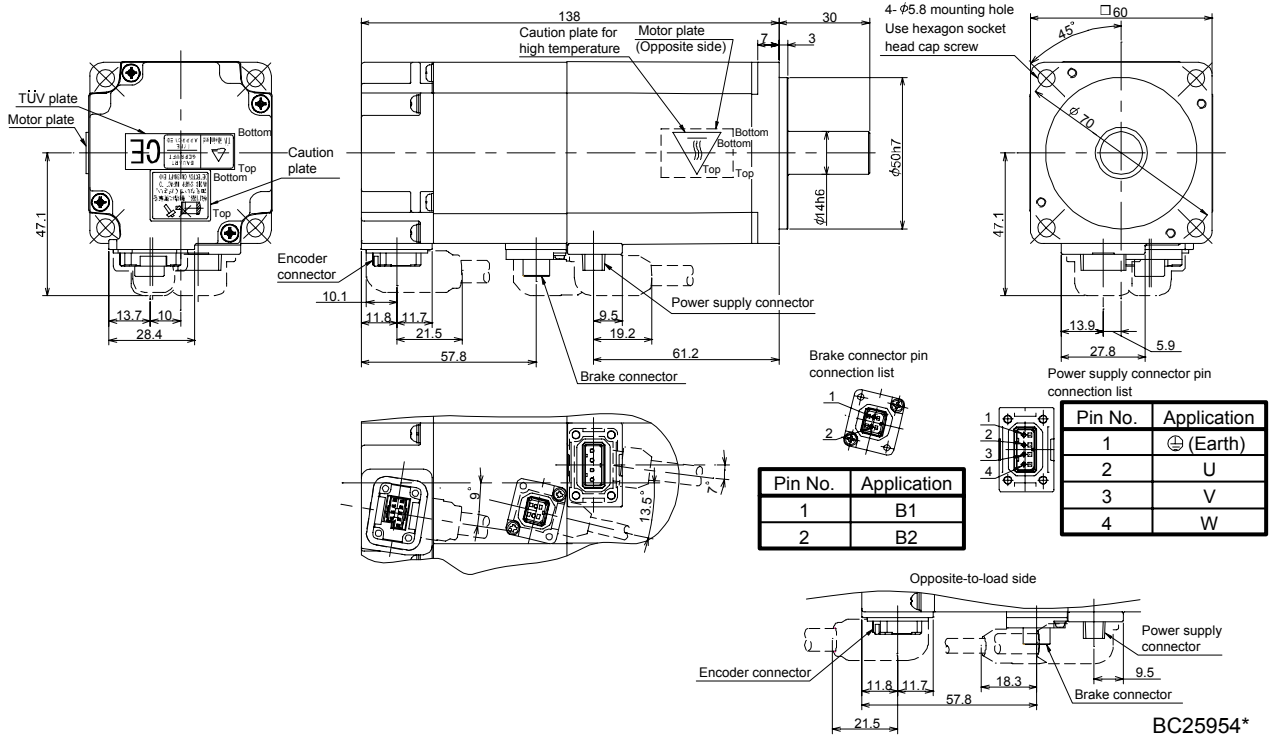

## 6. HF-MP SERIES · HF-KP SERIES

Model	Output [W]	Brake static friction torque [N · m] ([oz · in])	Inertia moment J [ $\times 10^{-4}$ kg · m <sup>2</sup> ] (WK <sup>2</sup> [oz · in <sup>2</sup> ])	Mass [kg] ([lb])
HF-MP73B	750	2.4 (340)	0.70 (3.83)	3.9 (8.60)
HF-KP73B	750	2.4 (340)	1.63 (8.91)	3.9 (8.60)

[Unit: mm]

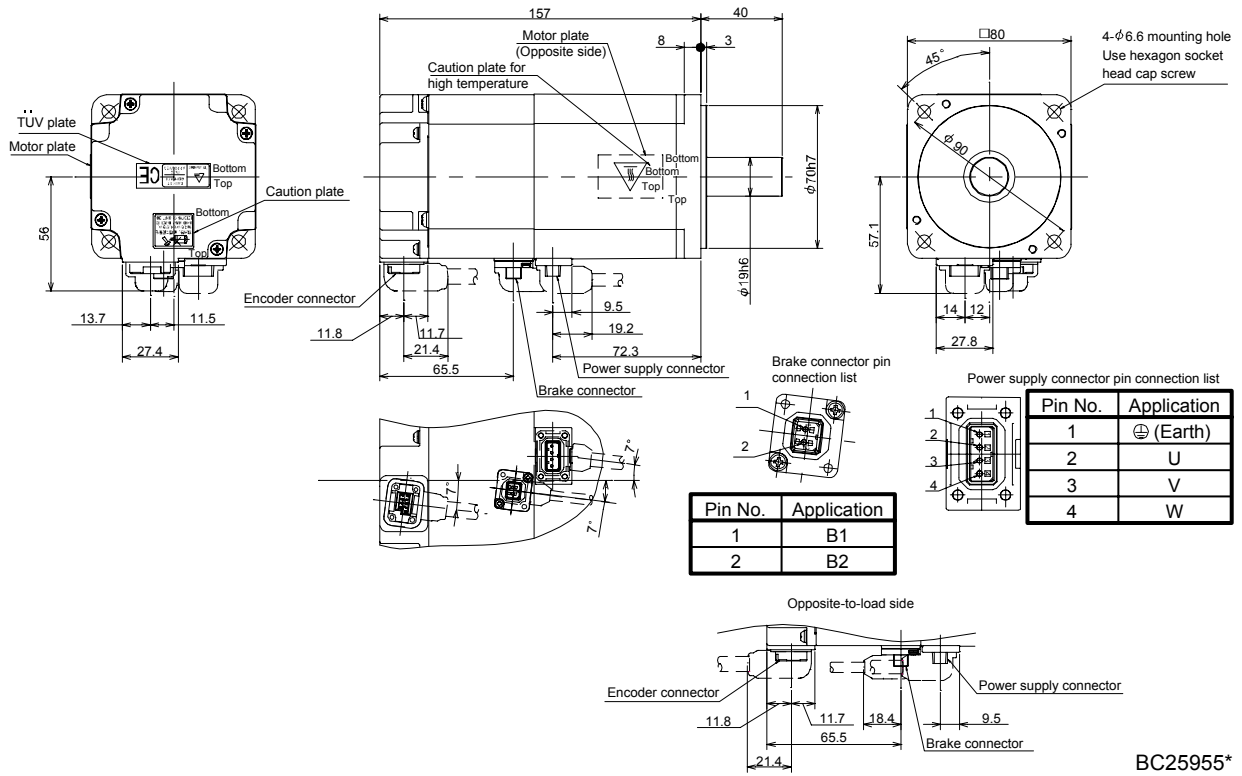

BC25955\*

## 6. HF-MP SERIES · HF-KP SERIES

### 6.8.3 For general industrial machine with a reduction gear (without an electromagnetic brake)

Model	Output [W]	Reduction gear model	Reduction ratio (Actual reduction ratio)	Inertia moment $J [\times 10^{-4} \text{kg} \cdot \text{m}^2]$ ( $\text{WK}^2$ [oz · in <sup>2</sup> ])	Mass [kg] ([lb])
HF-MP053G1	50	K6505	1/5 (9/44)	0.056 (0.306)	1.4 (3.09)
HF-KP053G1	50	K6505	1/5 (9/44)	0.089 (0.487)	1.4 (3.09)

[Unit: mm]

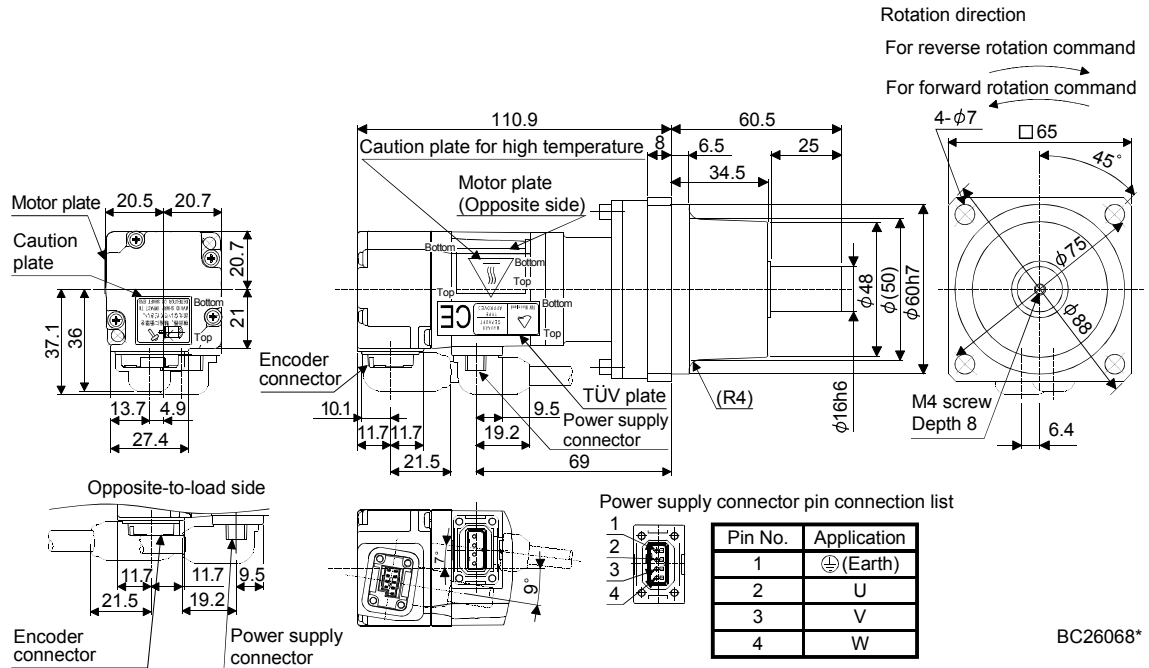

Model	Output [W]	Reduction gear model	Reduction ratio (Actual reduction ratio)	Inertia moment $J [\times 10^{-4} \text{kg} \cdot \text{m}^2]$ ( $\text{WK}^2$ [oz · in <sup>2</sup> ])	Mass [kg] ([lb])
HF-MP053G1	50	K6512	1/12 (49/576)	0.078 (0.426)	1.8 (3.97)
		K6520	1/20 (25/484)	0.060 (0.328)	
HF-KP053G1	50	K6512	1/12 (49/576)	0.111 (0.607)	1.8 (3.97)
		K6520	1/20 (25/484)	0.093 (0.508)	

[Unit: mm]

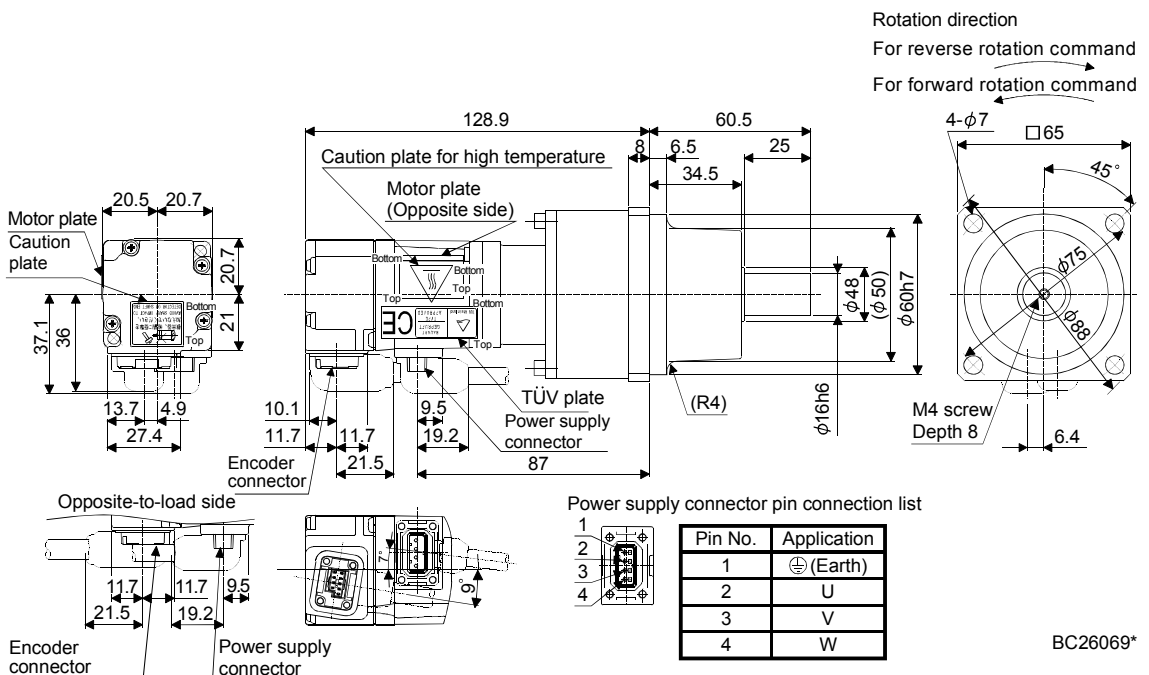



## 6. HF-MP SERIES · HF-KP SERIES

Model	Output [W]	Reduction gear model	Reduction ratio (Actual reduction ratio)	Inertia moment $J [\times 10^{-4} \text{kg} \cdot \text{m}^2] (\text{WK}^2 [\text{oz} \cdot \text{in}^2])$	Mass [kg] ([lb])
HF-MP13G1	100	K6505	1/5 (9/44)	0.069 (0.377)	1.6 (3.53)
HF-KP13G1	100	K6505	1/5 (9/44)	0.125 (0.683)	1.6 (3.53)

[Unit: mm]

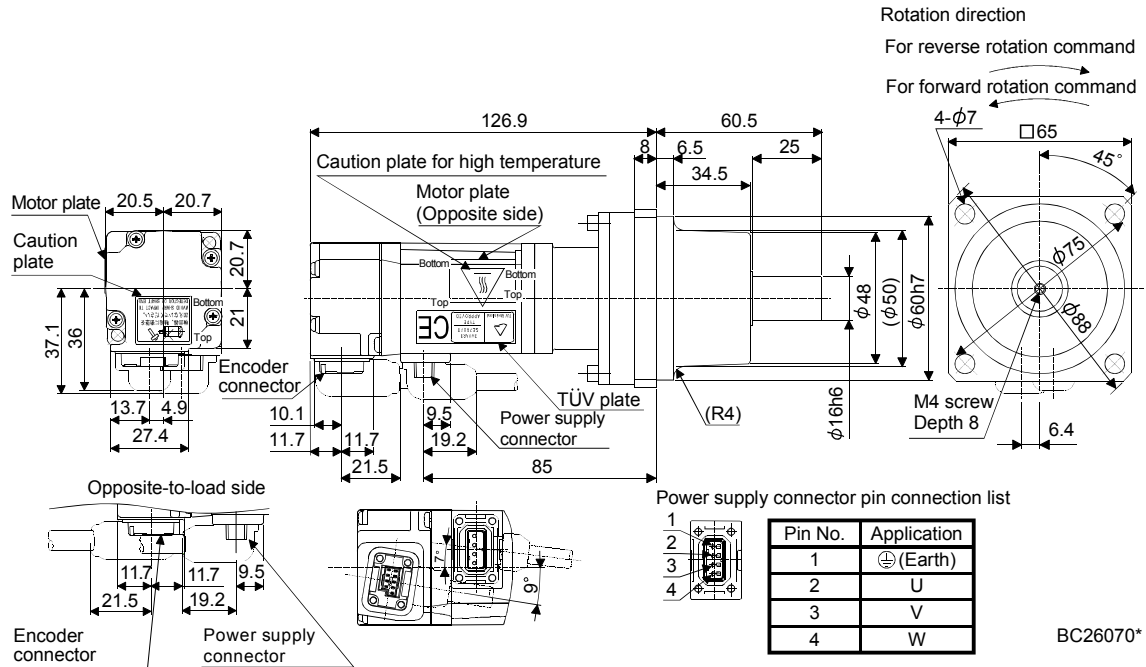

Model	Output [W]	Reduction gear model	Reduction ratio (Actual reduction ratio)	Inertia moment $J [\times 10^{-4} \text{kg} \cdot \text{m}^2] (\text{WK}^2 [\text{oz} \cdot \text{in}^2])$	Mass [kg] ([lb])
HF-MP13G1	100	K6512	1/12 (49/576)	0.091 (0.498)	2.0 (4.19)
		K6520	1/20 (25/484)	0.073 (0.399)	
HF-KP13G1	100	K6512	1/12 (49/576)	0.147 (0.804)	2.0 (4.19)
		K6520	1/20 (25/484)	0.129 (0.705)	

[Unit: mm]

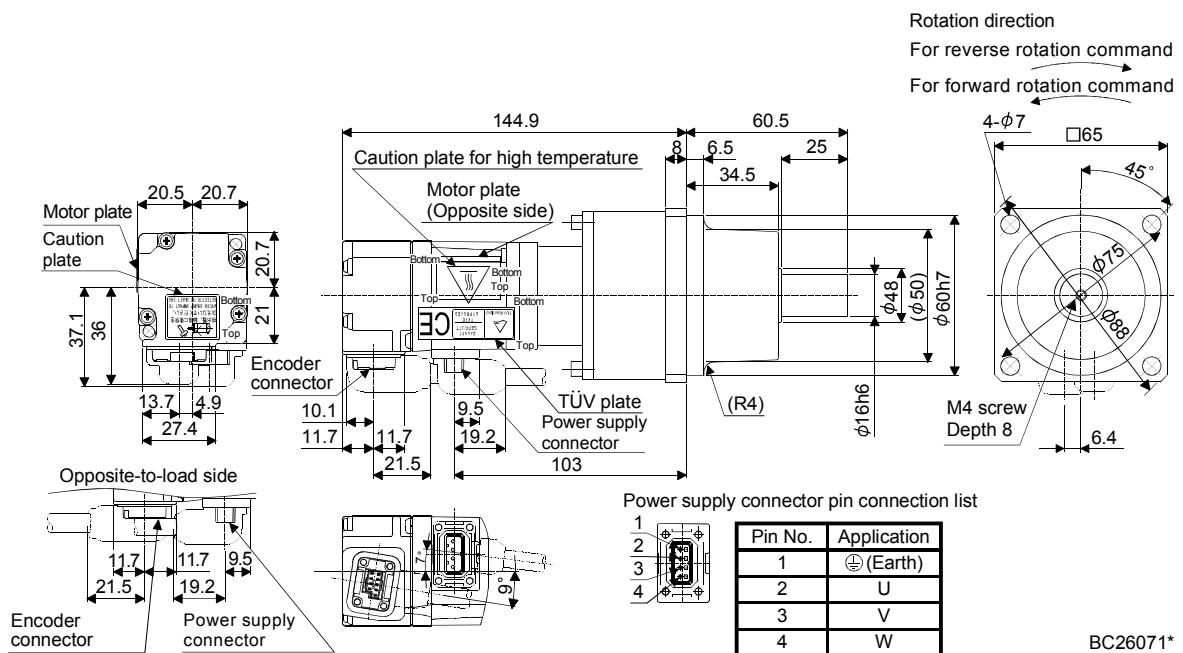

## 6. HF-MP SERIES · HF-KP SERIES

Model	Output [W]	Reduction gear model	Reduction ratio (Actual reduction ratio)	Inertia moment $J [\times 10^{-4} \text{kg} \cdot \text{m}^2] (\text{WK}^2 [\text{oz} \cdot \text{in}^2])$	Mass [kg] ([lb])
HF-MP23G1	200	K9005	1/5 (19/96)	0.248 (1.36)	3.3 (7.28)
HF-KP23G1	200	K9005	1/5 (19/96)	0.400 (2.19)	3.3 (7.28)

[Unit: mm]

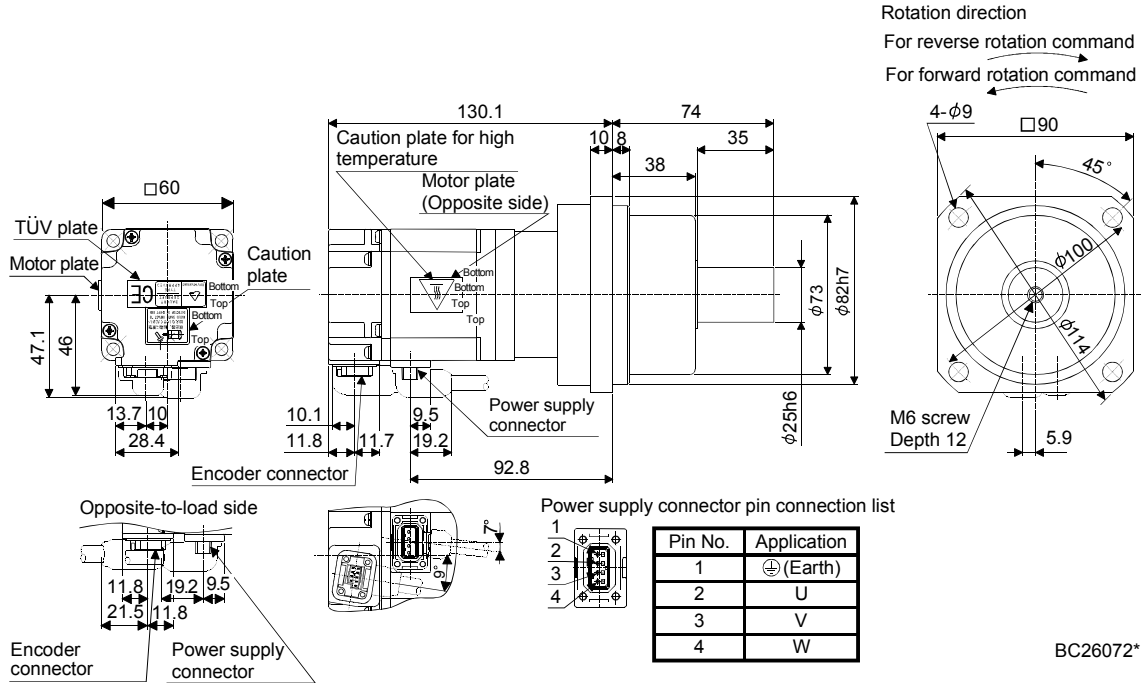

Model	Output [W]	Reduction gear model	Reduction ratio (Actual reduction ratio)	Inertia moment $J [\times 10^{-4} \text{kg} \cdot \text{m}^2] (\text{WK}^2 [\text{oz} \cdot \text{in}^2])$	Mass [kg] ([lb])
HF-MP23G1	200	K9012	1/12 (25/288)	0.298 (1.63)	3.9 (8.60)
		K9020	1/20 (253/5000)	0.268 (1.47)	
HF-KP23G1	200	K9012	1/12 (25/288)	0.450 (2.46)	3.9 (8.60)
		K9020	1/20 (253/5000)	0.420 (2.30)	

[Unit: mm]

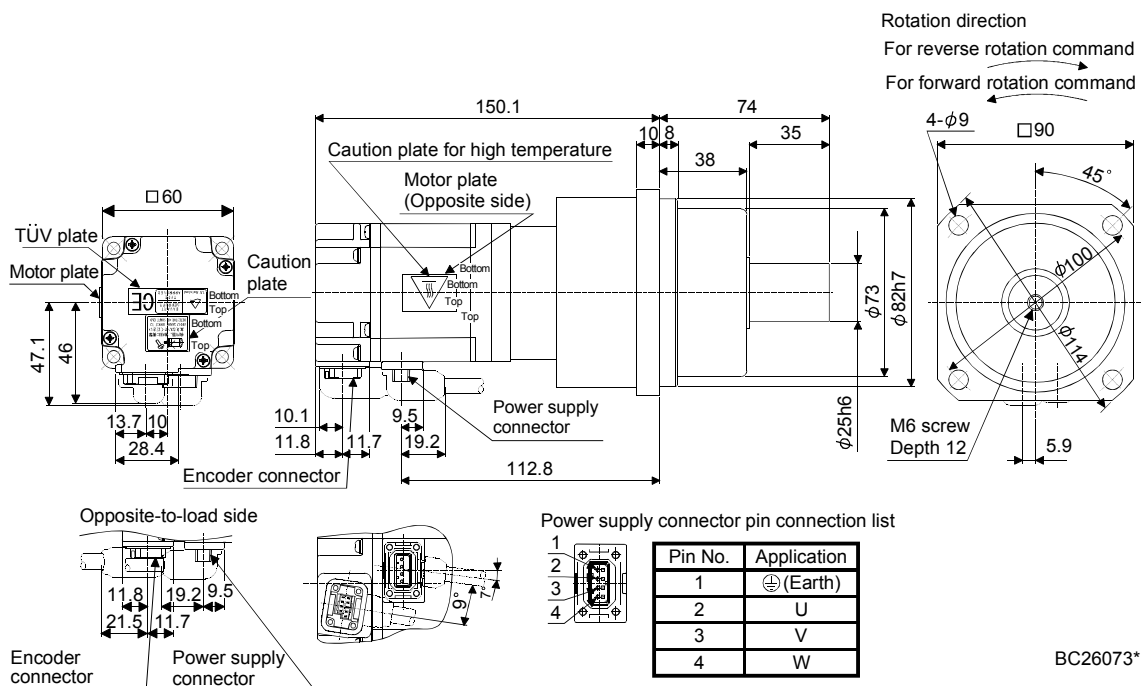

## 6. HF-MP SERIES · HF-KP SERIES

Model	Output [W]	Reduction gear model	Reduction ratio (Actual reduction ratio)	Inertia moment $J [ \times 10^{-4} \text{kg} \cdot \text{m}^2 ] ( \text{WK}^2 [\text{oz} \cdot \text{in}^2] )$	Mass [kg] ([lb])
HF-MP43G1	400	K9005	1/5 (19/96)	0.300 (1.64)	3.9 (8.60)
HF-KP43G1	400	K9005	1/5 (19/96)	0.570 (3.12)	3.9 (8.60)

[Unit: mm]

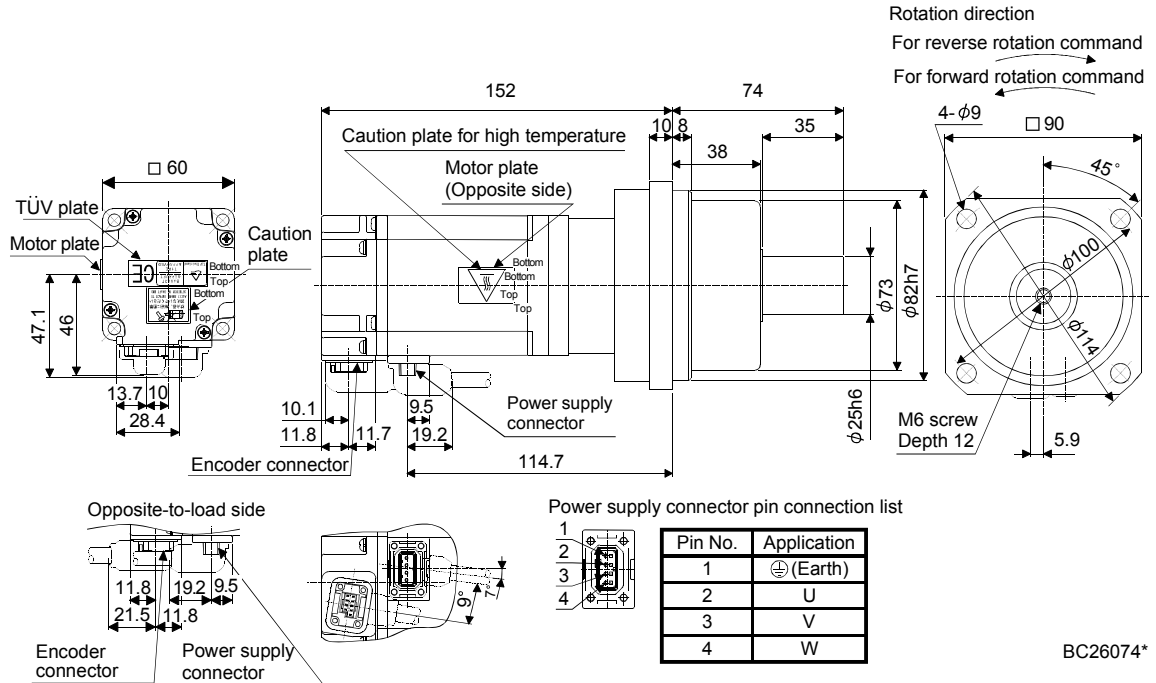

Model	Output [W]	Reduction gear model	Reduction ratio (Actual reduction ratio)	Inertia moment $J [ \times 10^{-4} \text{kg} \cdot \text{m}^2 ] ( \text{WK}^2 [\text{oz} \cdot \text{in}^2] )$	Mass [kg] ([lb])
HF-MP43G1	400	K9012	1/12 (25/288)	0.350 (1.91)	4.5 (9.92)
HF-KP43G1	400	K9012	1/12 (25/288)	0.620 (3.39)	4.5 (9.92)

[Unit: mm]

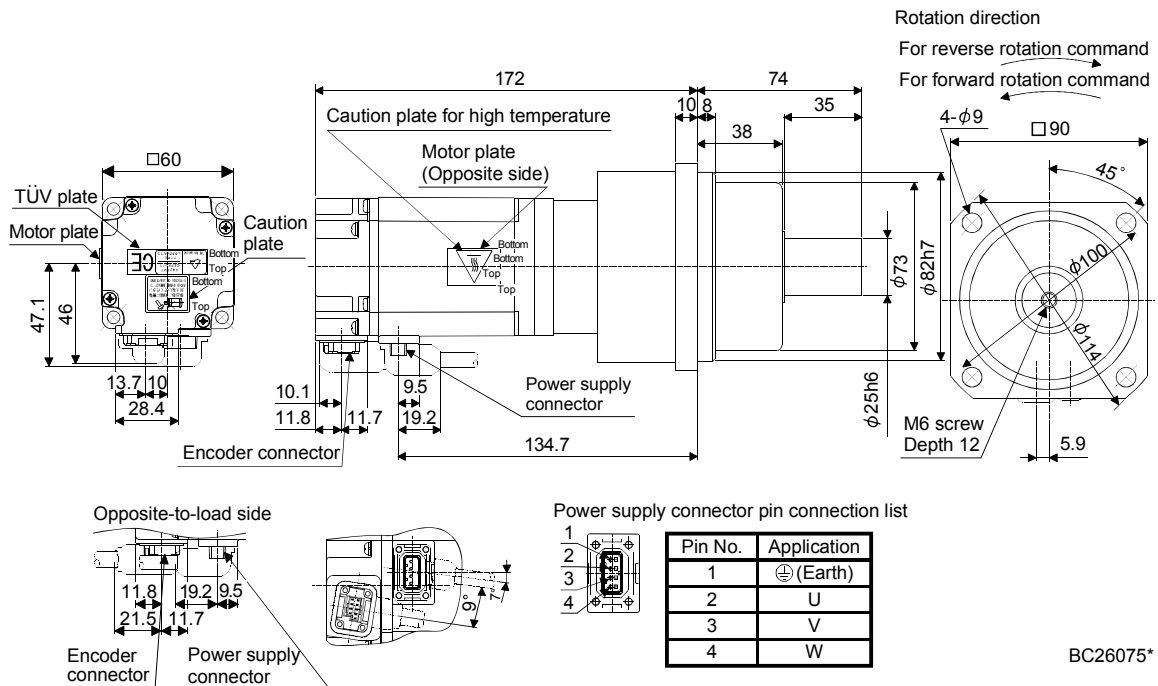

## 6. HF-MP SERIES · HF-KP SERIES

Model	Output [W]	Reduction gear model	Reduction ratio (Actual reduction ratio)	Inertia moment $J [\times 10^{-4} \text{kg} \cdot \text{m}^2]$ ( $\text{WK}^2$ [oz · in <sup>2</sup> ])	Mass [kg] ([lb])
HF-MP43G1	400	K10020	1/20 (253/5000)	0.660 (3.61)	5.6 (12.3)
HF-KP43G1	400	K10020	1/20 (253/5000)	0.930 (5.09)	5.6 (12.3)

[Unit: mm]

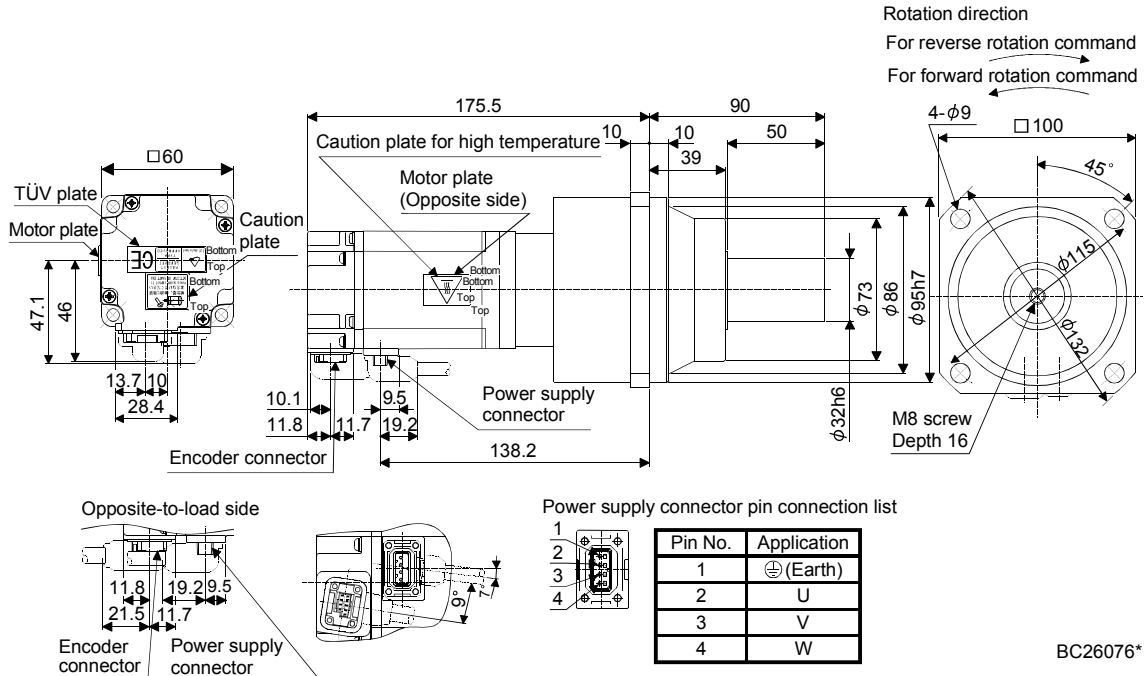

Model	Output [W]	Reduction gear model	Reduction ratio (Actual reduction ratio)	Inertia moment $J [\times 10^{-4} \text{kg} \cdot \text{m}^2]$ ( $\text{WK}^2$ [oz · in <sup>2</sup> ])	Mass [kg] ([lb])
HF-MP73G1	750	K10005	1/5 (1/5)	1.02 (5.58)	6.1 (13.4)
HF-KP73G1	750	K10005	1/5 (1/5)	1.85 (10.1)	6.1 (13.4)

[Unit: mm]

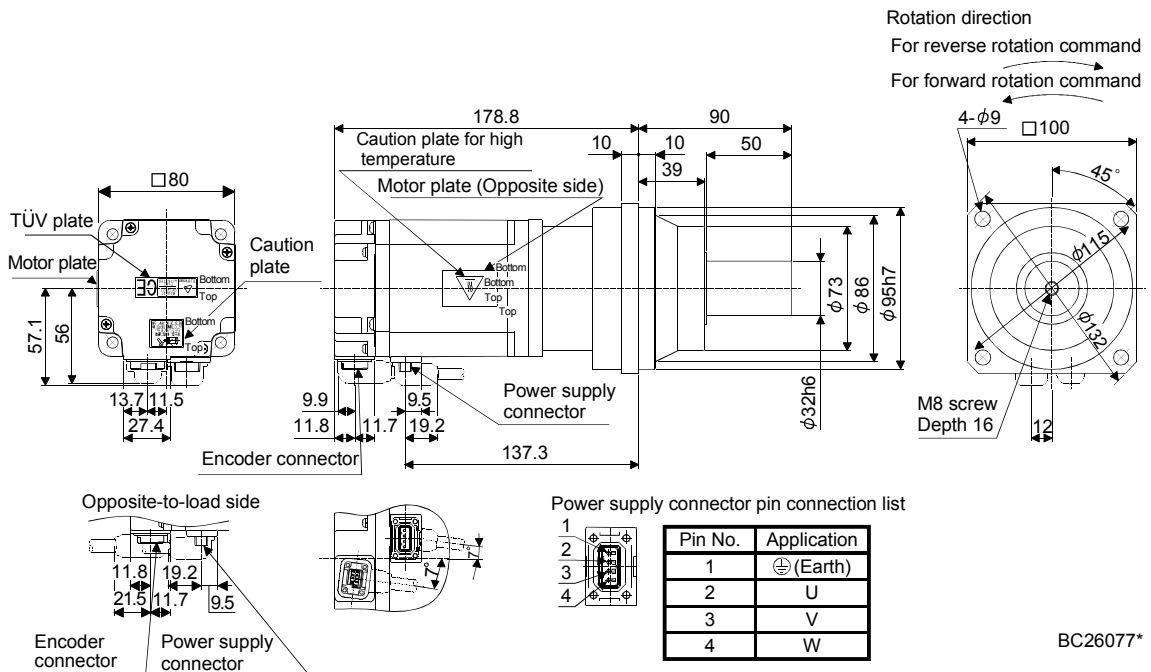

## 6. HF-MP SERIES · HF-KP SERIES

Model	Output [W]	Reduction gear model	Reduction ratio (Actual reduction ratio)	Inertia moment $J [\times 10^{-4} \text{kg} \cdot \text{m}^2] (\text{WK}^2 [\text{oz} \cdot \text{in}^2])$	Mass [kg] ([lb])
HF-MP73G1	750	K10012	1/12 (525/6048)	1.69 (9.24)	7.2 (15.9)
HF-KP73G1	750	K10012	1/12 (525/6048)	2.52 (13.8)	7.2 (15.9)

[Unit: mm]

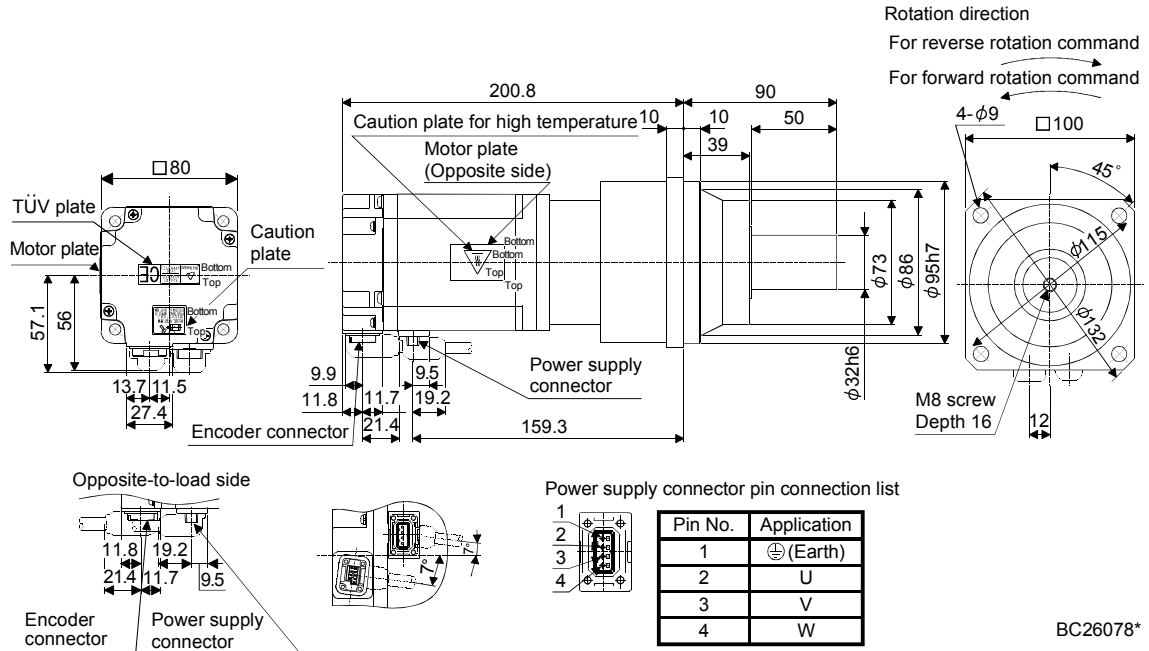

Model	Output [W]	Reduction gear model	Reduction ratio (Actual reduction ratio)	Inertia moment $J [\times 10^{-4} \text{kg} \cdot \text{m}^2] (\text{WK}^2 [\text{oz} \cdot \text{in}^2])$	Mass [kg] ([lb])
HF-MP73G1	750	K12020	1/20 (625/12544)	1.75 (9.57)	10 (22.0)
HF-KP73G1	750	K12020	1/20 (625/12544)	2.58 (14.1)	10 (22.0)

[Unit: mm]

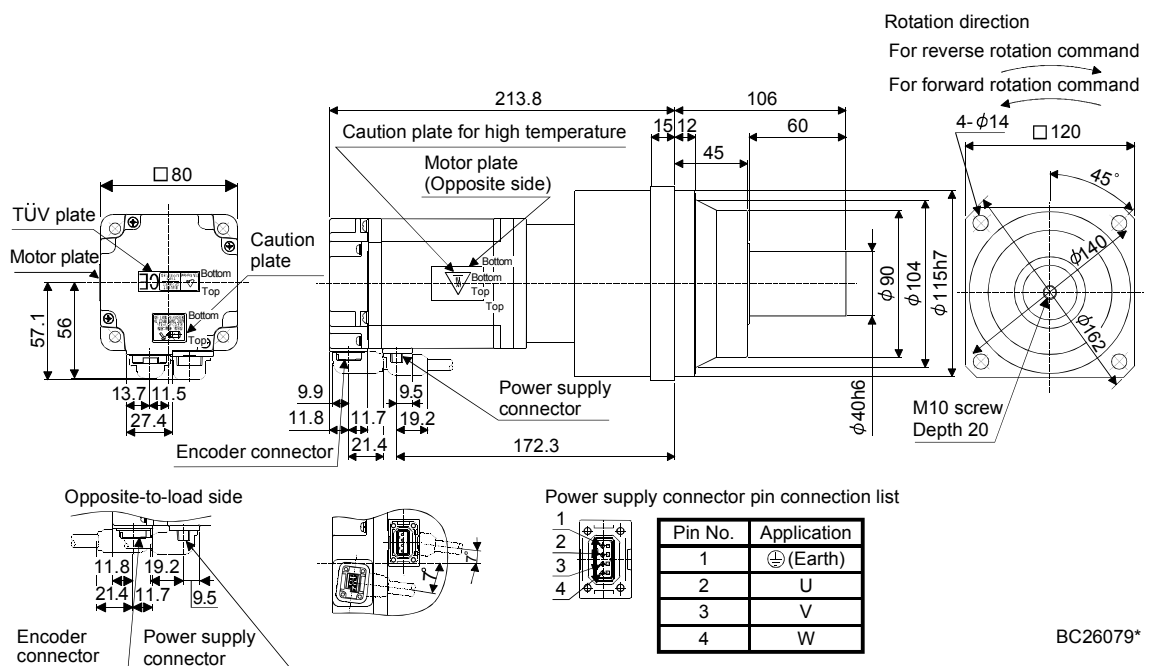

## 6. HF-MP SERIES · HF-KP SERIES

### 6.8.4 For general industrial machine with a reduction gear (with an electromagnetic brake)

Model	Output [W]	Brake static friction torque [N · m] (oz · in)	Reduction gear model	Reduction ratio (Actual reduction ratio)	Inertia moment J [ $\times 10^{-4}$ kg · m <sup>2</sup> ] (WK <sup>2</sup> [oz · in <sup>2</sup> ])	Mass [kg] (lb)
HF-MP053BG1	50	0.32 (45.3)	K6505	1/5 (9/44)	0.062 (0.339)	1.7 (3.75)
HF-KP053BG1	50	0.32 (45.3)	K6505	1/5 (9/44)	0.091 (0.498)	1.7 (3.75)

[Unit: mm]

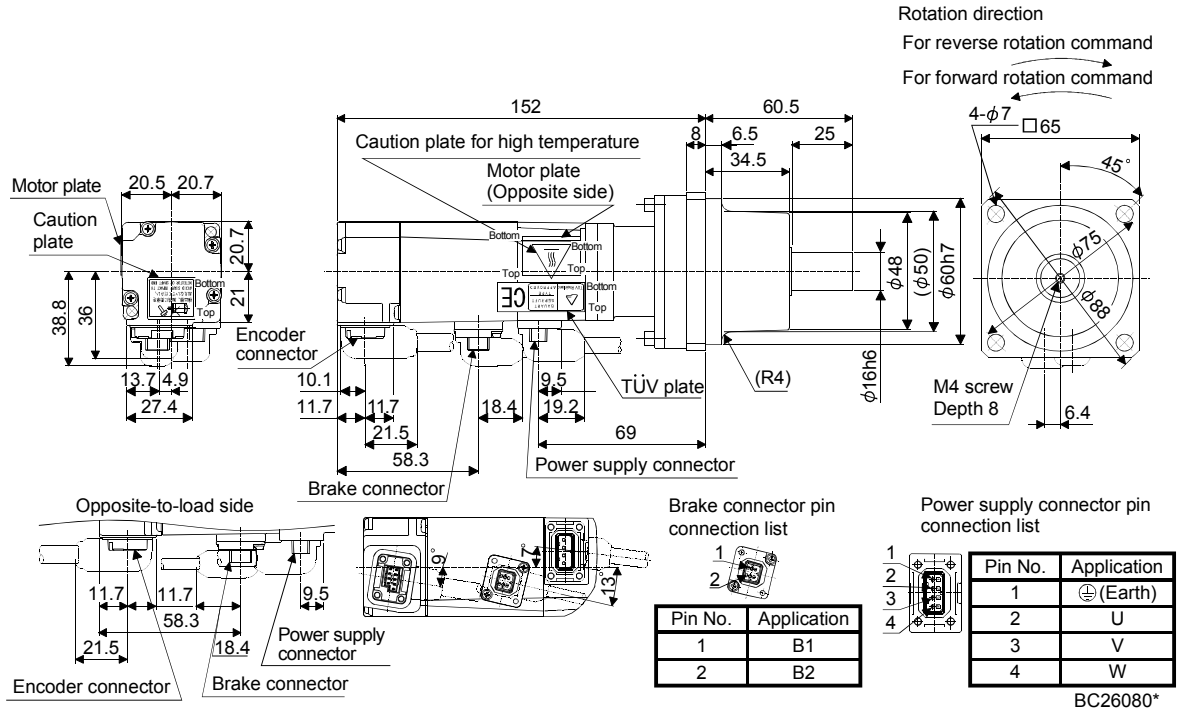

Model	Output [W]	Brake static friction torque [N · m] (oz · in)	Reduction gear model	Reduction ratio (Actual reduction ratio)	Inertia moment J [ $\times 10^{-4}$ kg · m <sup>2</sup> ] (WK <sup>2</sup> [oz · in <sup>2</sup> ])	Mass [kg] (lb)
HF-MP053BG1	50	0.32 (45.3)	K6512	1/12 (49/576)	0.084 (0.459)	2.1 (4.63)
			K6520	1/20 (25/484)	0.066 (0.361)	
HF-KP053BG1	50	0.32 (45.3)	K6512	1/12 (49/576)	0.113 (0.618)	2.1 (4.63)
			K6520	1/20 (25/484)	0.095 (0.519)	

[Unit: mm]

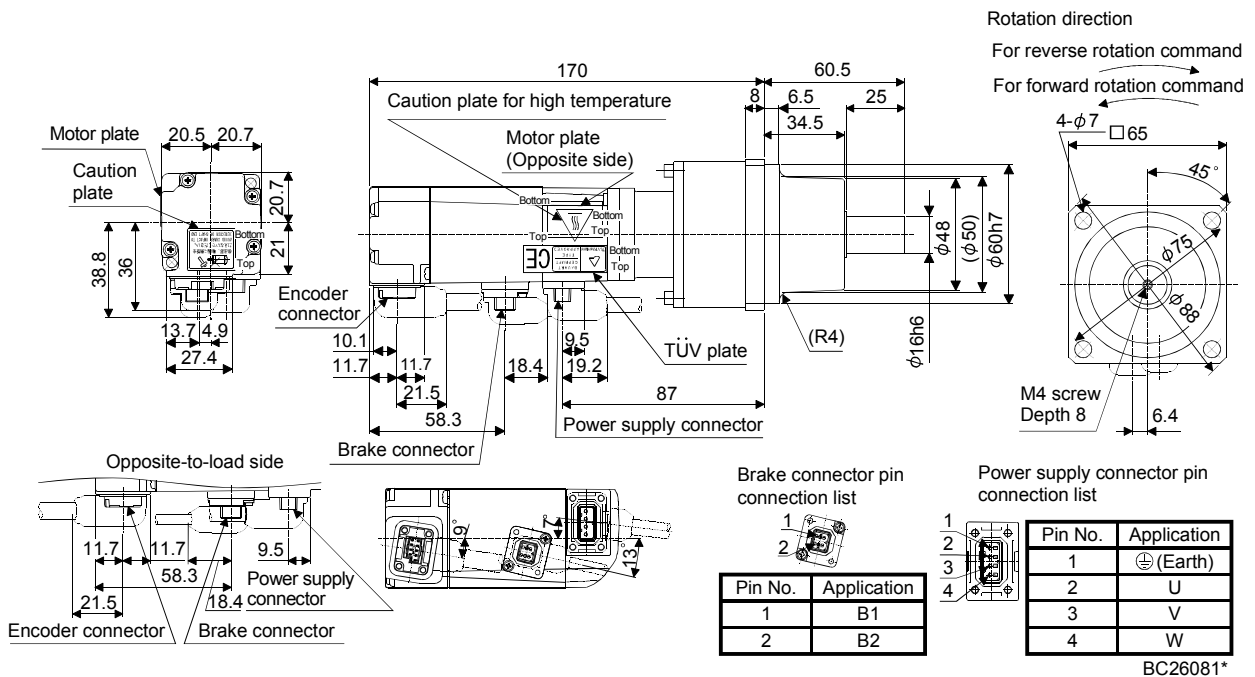

## 6. HF-MP SERIES · HF-KP SERIES

Model	Output [W]	Brake static friction torque [N · m] ([oz · in])	Reduction gear model	Reduction ratio (Actual reduction ratio)	Inertia moment $J [\times 10^{-4} \text{kg} \cdot \text{m}^2] (\text{WK}^2 [\text{oz} \cdot \text{in}^2])$	Mass [kg] ([lb])
HF-MP13BG1	100	0.32 (45.3)	K6505	1/5 (9/44)	0.076 (0.416)	1.9 (4.19)
HF-KP13BG1	100	0.32 (45.3)	K6505	1/5 (9/44)	0.127 (0.694)	1.9 (4.19)

[Unit: mm]

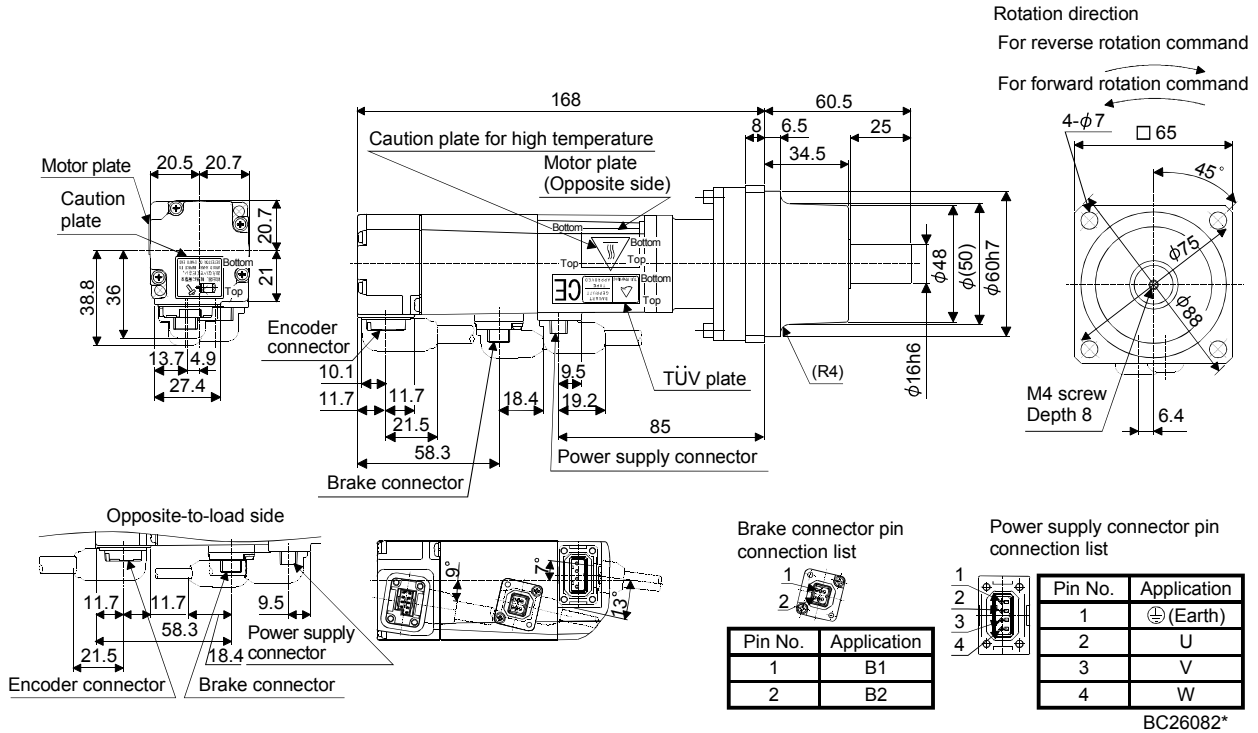

Model	Output [W]	Brake static friction torque [N · m] ([oz · in])	Reduction gear model	Reduction ratio (Actual reduction ratio)	Inertia moment $J [\times 10^{-4} \text{kg} \cdot \text{m}^2] (\text{WK}^2 [\text{oz} \cdot \text{in}^2])$	Mass [kg] ([lb])
HF-MP13BG1	100	0.32 (45.3)	K6512	1/12 (49/576)	0.098 (0.536)	2.3 (5.07)
			K6520	1/20 (25/484)	0.080 (0.437)	
HF-KP13BG1	100	0.32 (45.3)	K6512	1/12 (49/576)	0.149 (0.815)	2.3 (5.07)
			K6520	1/20 (25/484)	0.131 (0.716)	

[Unit: mm]

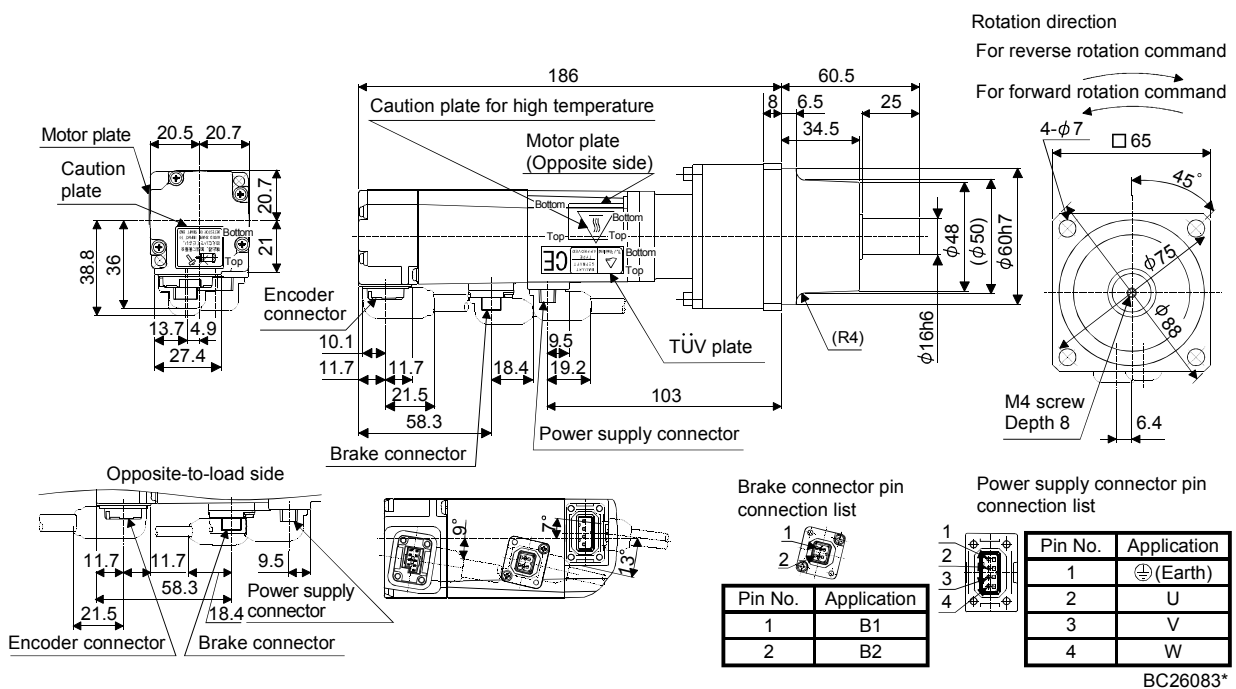

## 6. HF-MP SERIES · HF-KP SERIES

Model	Output [W]	Brake static friction torque [N · m] (oz · in)	Reduction gear model	Reduction ratio (Actual reduction ratio)	Inertia moment $J [ \times 10^{-4} \text{kg} \cdot \text{m}^2 ] ( \text{WK}^2 [ \text{oz} \cdot \text{in}^2 ] )$	Mass [kg] (lb)
HF-MP23BG1	200	1.3 (184)	K9005	1/5 (19/96)	0.280 (1.53)	3.9 (8.60)
HF-KP23BG1	200	1.3 (184)	K9005	1/5 (19/96)	0.470 (2.57)	3.9 (8.60)

[Unit: mm]

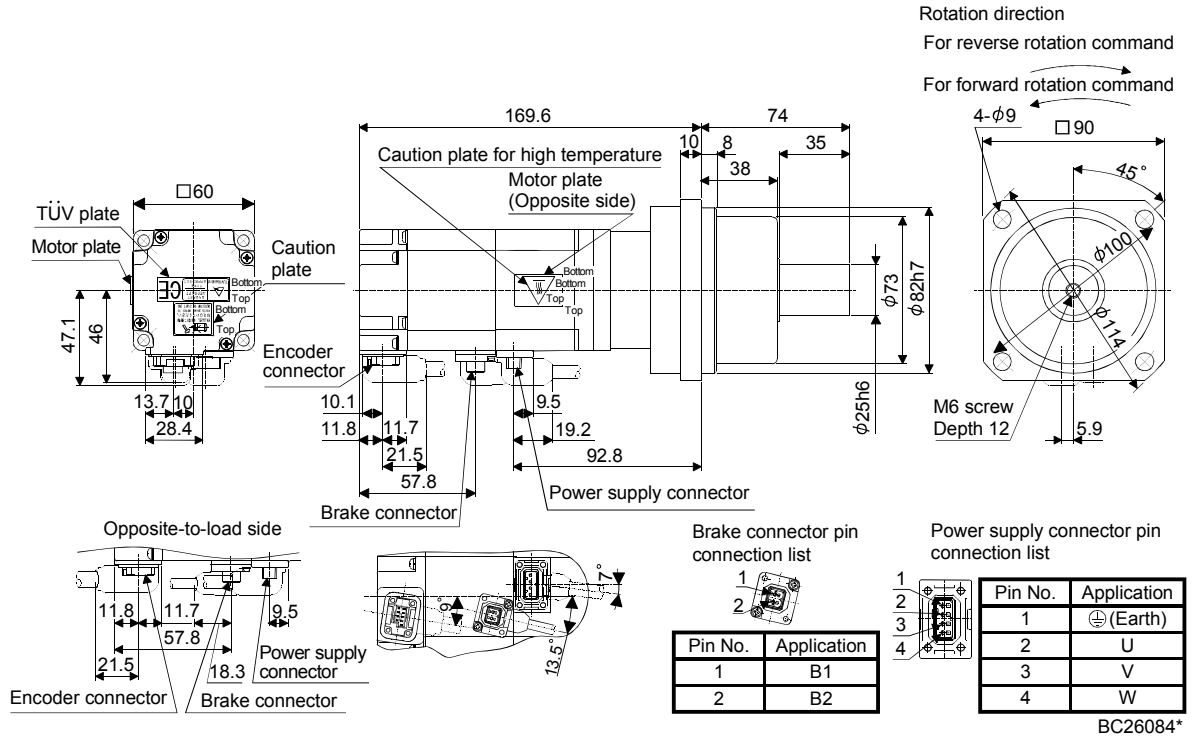



## 6. HF-MP SERIES · HF-KP SERIES

Model	Output [W]	Brake static friction torque [N · m] (oz · in)	Reduction gear model	Reduction ratio (Actual reduction ratio)	Inertia moment J [ $\times 10^{-4}$ kg · m <sup>2</sup> ] (WK <sup>2</sup> [oz · in <sup>2</sup> ])	Mass [kg] (lb)
HF-MP23BG1	200	1.3 (184)	K9012	1/12 (25/288)	0.330 (1.80)	4.5 (9.92)
			K9020	1/20 (253/5000)	0.300 (1.64)	
HF-KP23BG1	200	1.3 (184)	K9012	1/12 (25/288)	0.520 (2.84)	4.5 (9.92)
			K9020	1/20 (253/5000)	0.490 (2.68)	

[Unit: mm]

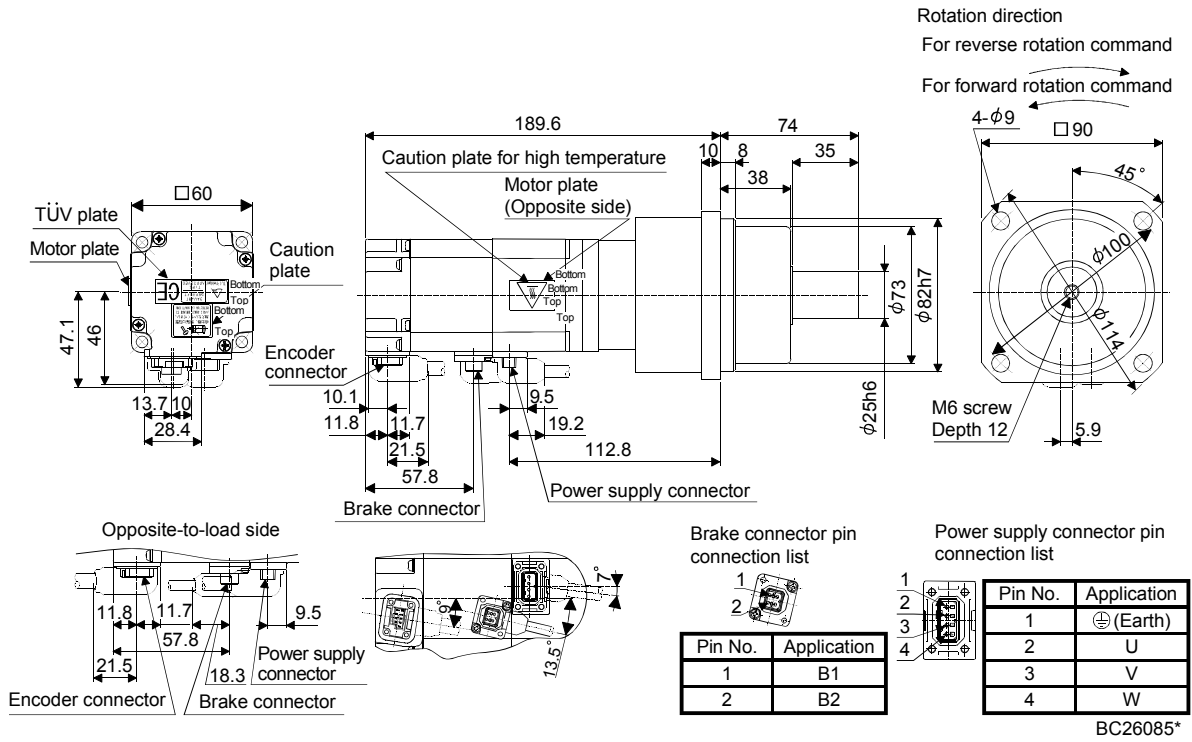

## 6. HF-MP SERIES · HF-KP SERIES

Model	Output [W]	Brake static friction torque [N · m] ([oz · in])	Reduction gear model	Reduction ratio (Actual reduction ratio)	Inertia moment $J [\times 10^{-4} \text{kg} \cdot \text{m}^2] (\text{WK}^2 [\text{oz} \cdot \text{in}^2])$	Mass [kg] ([lb])
HF-MP43BG1	400	1.3 (184)	K9005	1/5 (19/96)	0.330 (1.80)	4.4 (9.7)
HF-KP43BG1	400	1.3 (184)	K9005	1/5 (19/96)	0.650 (3.55)	4.4 (9.7)

[Unit: mm]

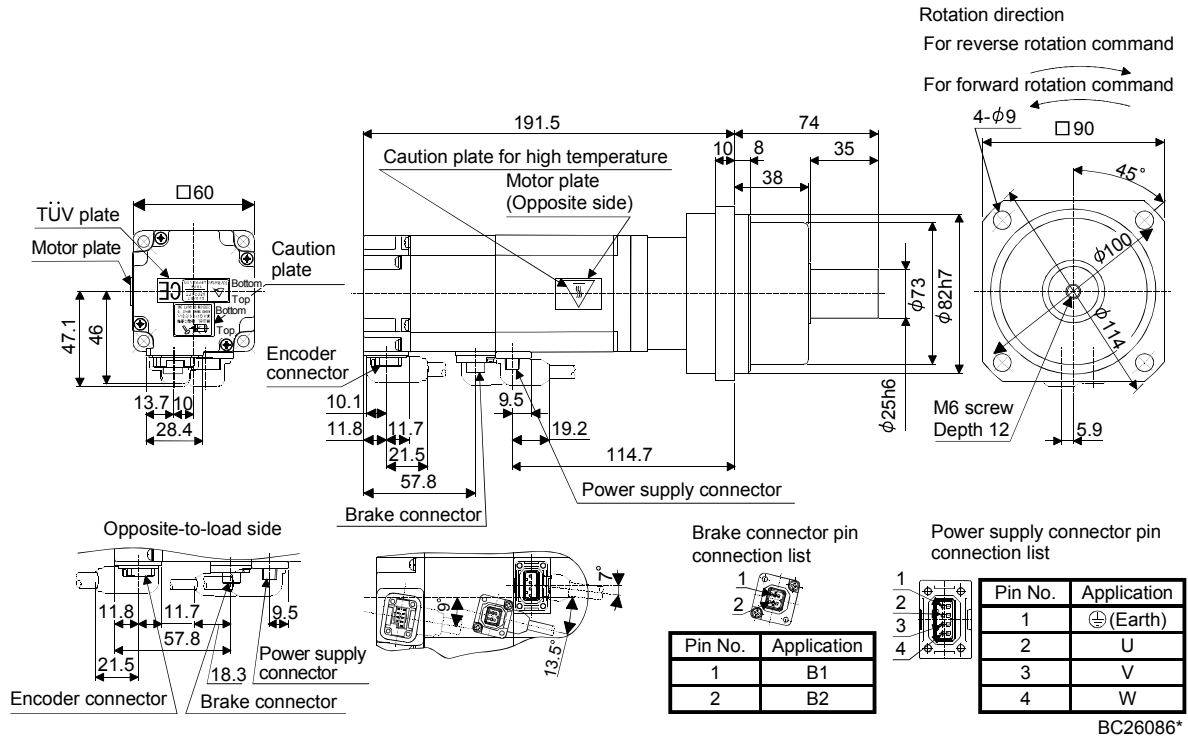

Model	Output [W]	Brake static friction torque [N · m] ([oz · in])	Reduction gear model	Reduction ratio (Actual reduction ratio)	Inertia moment $J [\times 10^{-4} \text{kg} \cdot \text{m}^2] (\text{WK}^2 [\text{oz} \cdot \text{in}^2])$	Mass [kg] ([lb])
HF-MP43BG1	400	1.3 (184)	K9012	1/12 (25/288)	0.380 (2.08)	5.0 (11.0)
HF-KP43BG1	400	1.3 (184)	K9012	1/12 (25/288)	0.700 (3.83)	5.0 (11.0)

[Unit: mm]

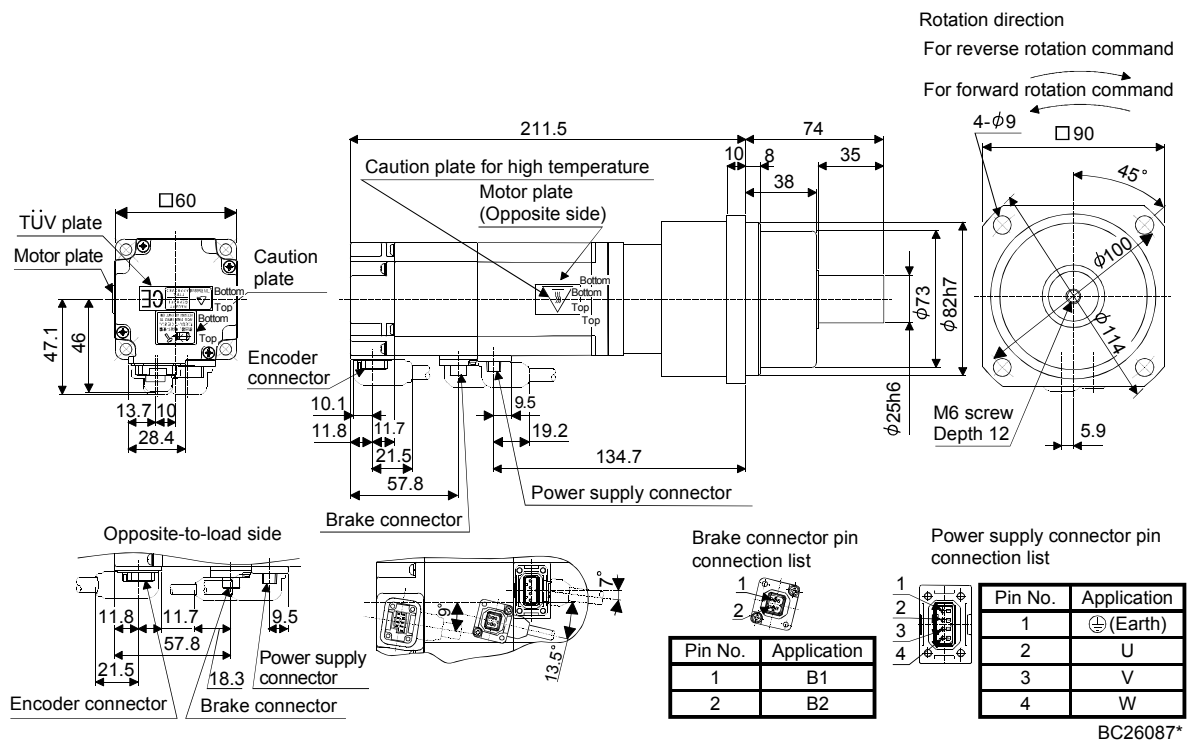

## 6. HF-MP SERIES · HF-KP SERIES

Model	Output [W]	Brake static friction torque [N · m] (oz · in)	Reduction gear model	Reduction ratio (Actual reduction ratio)	Inertia moment $J$ [ $\times 10^{-4}$ kg · m <sup>2</sup> ] (WK <sup>2</sup> [oz · in <sup>2</sup> ])	Mass [kg] (lb)
HF-MP43BG1	400	1.3 (184)	K10020	1/20 (253/5000)	0.690 (3.77)	6.1 (13.4)
HF-KP43BG1	400	1.3 (184)	K10020	1/20 (253/5000)	1.01 (5.52)	6.1 (13.4)

[Unit: mm]

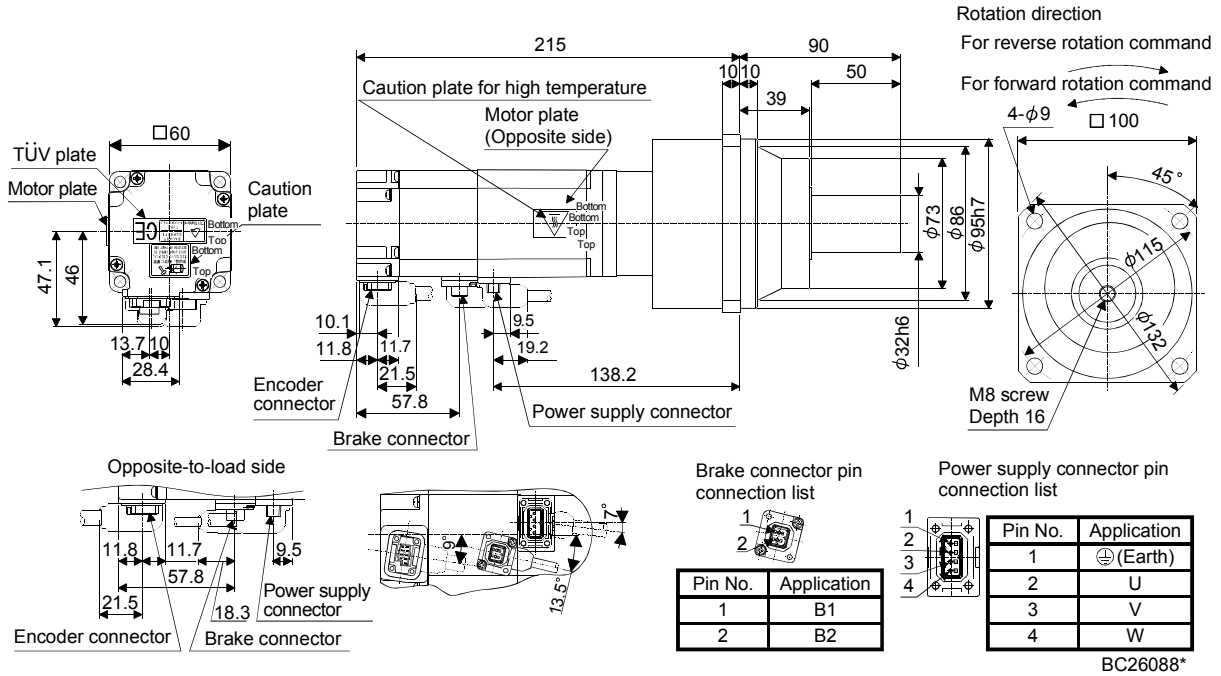

Model	Output [W]	Brake static friction torque [N · m] (oz · in)	Reduction gear model	Reduction ratio (Actual reduction ratio)	Inertia moment $J$ [ $\times 10^{-4}$ kg · m <sup>2</sup> ] (WK <sup>2</sup> [oz · in <sup>2</sup> ])	Mass [kg] (lb)
HF-MP73BG1	750	2.4 (340)	K10005	1/5 (1/5)	1.12 (6.12)	7.1 (15.7)
HF-KP73BG1	750	2.4 (340)	K10005	1/5 (1/5)	2.05 (11.2)	7.1 (15.7)

[Unit: mm]

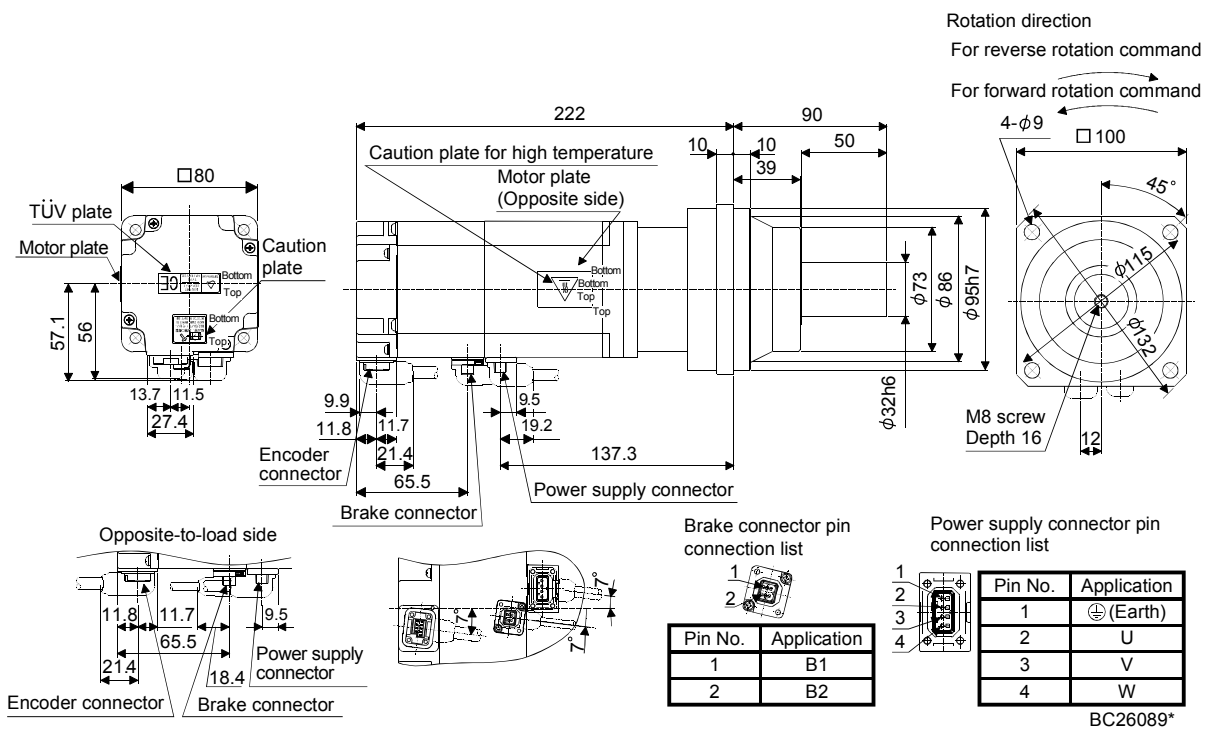

## 6. HF-MP SERIES · HF-KP SERIES

Model	Output [W]	Brake static friction torque [N · m] ([oz · in])	Reduction gear model	Reduction ratio (Actual reduction ratio)	Inertia moment $J$ [ $\times 10^{-4} \text{kg} \cdot \text{m}^2$ ] ( $\text{WK}^2$ [oz · in $^2$ ])	Mass [kg] ([lb])
HF-MP73BG1	750	2.4 (340)	K10012	1/12 (6048)	1.79 (8.79)	8.2 (18.1)
HF-KP73BG1	750	2.4 (340)	K10012	1/12 (6048)	2.72 (14.9)	8.2 (18.1)

[Unit: mm]

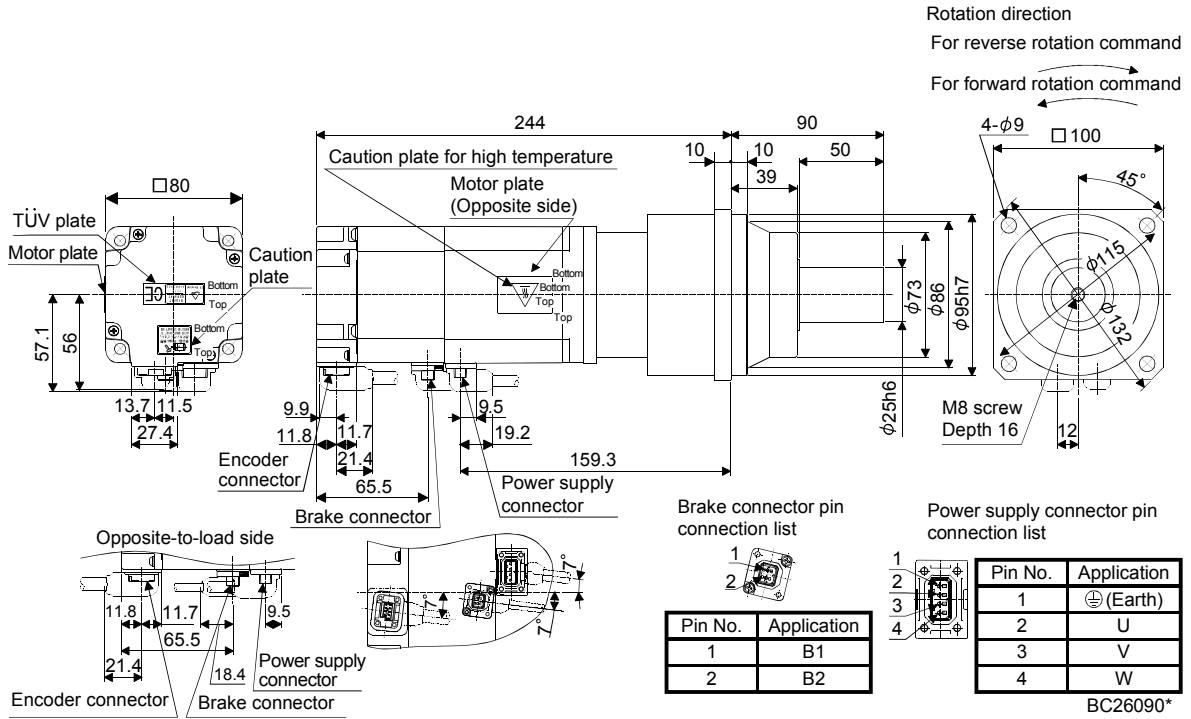

Model	Output [W]	Brake static friction torque [N · m] ([oz · in])	Reduction gear model	Reduction ratio (Actual reduction ratio)	Inertia moment $J$ [ $\times 10^{-4} \text{kg} \cdot \text{m}^2$ ] ( $\text{WK}^2$ [oz · in $^2$ ])	Mass [kg] ([lb])
HF-MP73BG1	750	2.4 (340)	K12020	1/20 (625/12544)	1.85 (10.1)	11 (24.3)
HF-KP73BG1	750	2.4 (340)	K12020	1/20 (625/12544)	2.78 (15.2)	11 (24.3)

[Unit: mm]

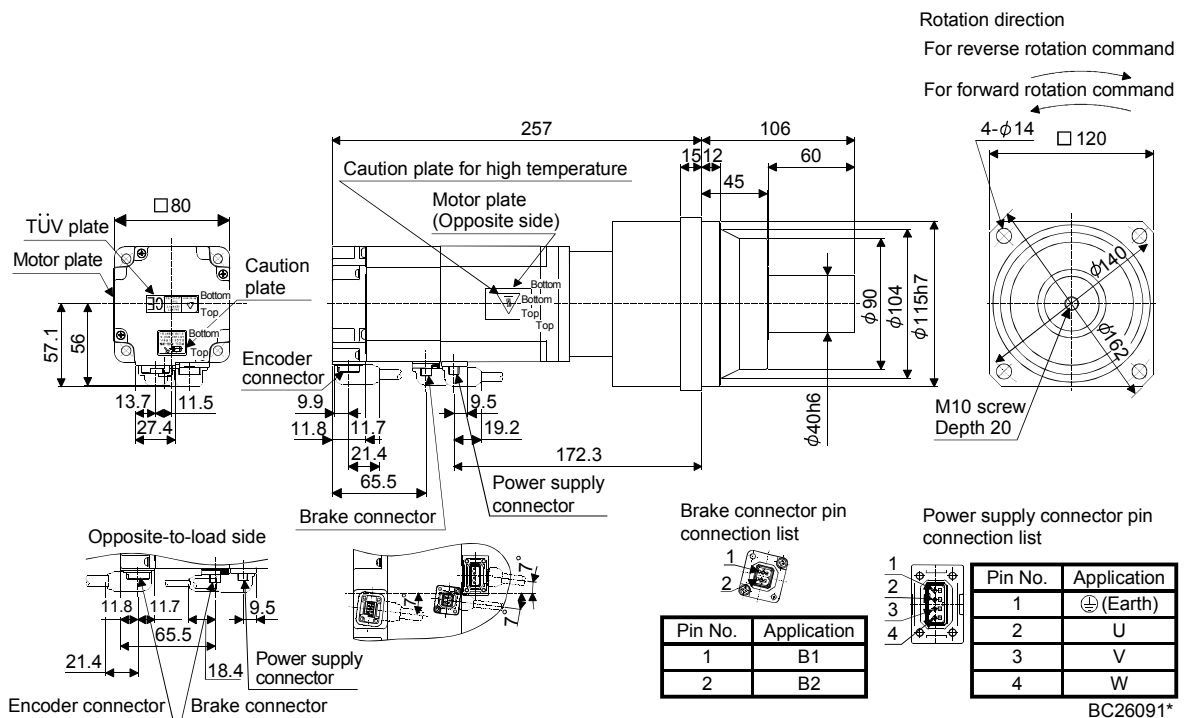

## 6. HF-MP SERIES · HF-KP SERIES

### 6.8.5 For precision application with flange mounting, flange output type reduction gear (without an electromagnetic brake)

Model	Output [W]	Reduction gear model	Reduction ratio	Inertia moment J [ $\times 10^{-4} \text{kg} \cdot \text{m}^2$ ] ( $\text{WK}^2 [\text{oz} \cdot \text{in}^2]$ )	Mass [kg] ([lb])
HF-MP053G5	50	HPG-14A-05-F0CBJS-S	1/5	0.087 (0.476)	1.1 (2.43)
		HPG-14A-11-F0CBKS-S	1/11	0.079 (0.432)	
		HPG-14A-21-F0CBKS-S	1/21	0.070 (0.383)	1.2 (2.64)
		HPG-14A-33-F0CBLS-S	1/33	0.064 (0.35)	
		HPG-14A-45-F0CBLS-S	1/45	0.064 (0.35)	
HF-KP053G5	50	HPG-14A-05-F0CBJS-S	1/5	0.120 (0.656)	1.1 (2.42)
		HPG-14A-11-F0CBKS-S	1/11	0.112 (0.612)	
		HPG-14A-21-F0CBKS-S	1/21	0.103 (0.563)	1.2 (2.65)
		HPG-14A-33-F0CBLS-S	1/33	0.097 (0.53)	
		HPG-14A-45-F0CBLS-S	1/45	0.097 (0.53)	

[Unit: mm]

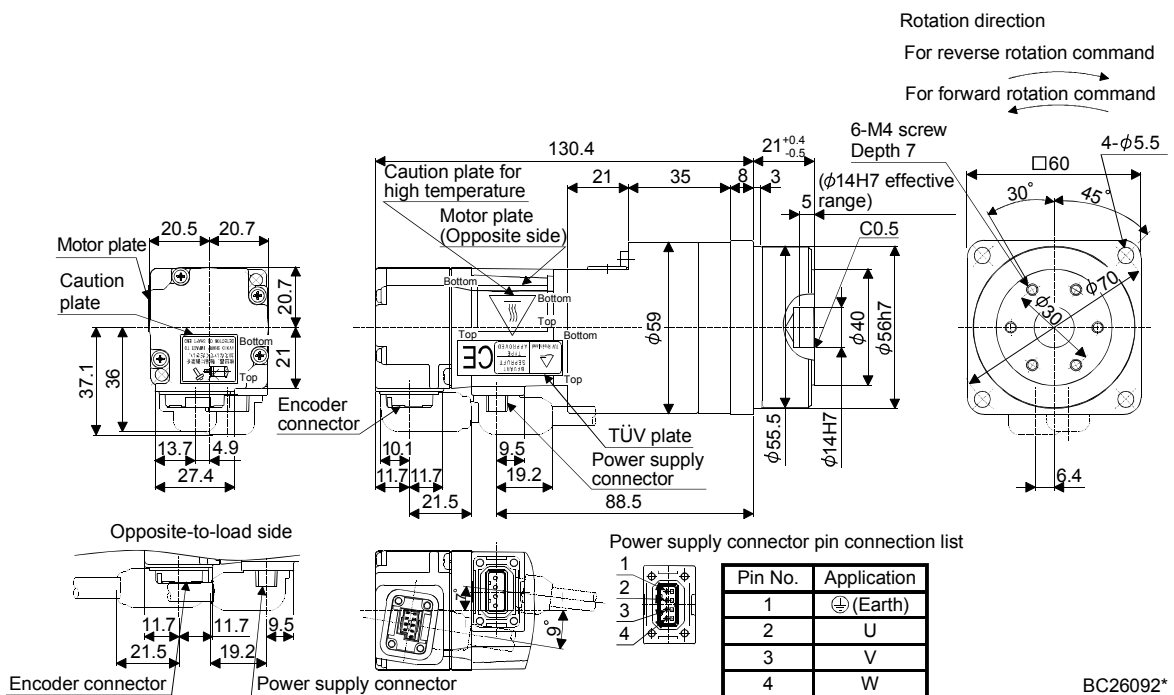

BC26092\*

## 6. HF-MP SERIES · HF-KP SERIES

Model	Output [W]	Reduction gear model	Reduction ratio	Inertia moment J [ $\times 10^{-4} \text{kg} \cdot \text{m}^2$ ] (WK <sup>2</sup> [oz · in <sup>2</sup> ])	Mass [kg] ([lb])
HF-MP13G5	100	HPG-14A-05-F0CBJS-S	1/5	0.100 (0.547)	1.3 (2.87)
		HPG-14A-11-F0CBKS-S	1/11	0.095 (0.519)	1.4 (3.09)
		HPG-14A-21-F0CBKS-S	1/21	0.083 (0.454)	1.4 (3.09)
HF-KP13G5	100	HPG-14A-05-F0CBJS-S	1/5	0.156 (0.853)	1.3 (2.87)
		HPG-14A-11-F0CBKS-S	1/11	0.148 (0.809)	1.4 (3.09)
		HPG-14A-21-F0CBKS-S	1/21	0.139 (0.76)	1.4 (3.09)

[Unit: mm]

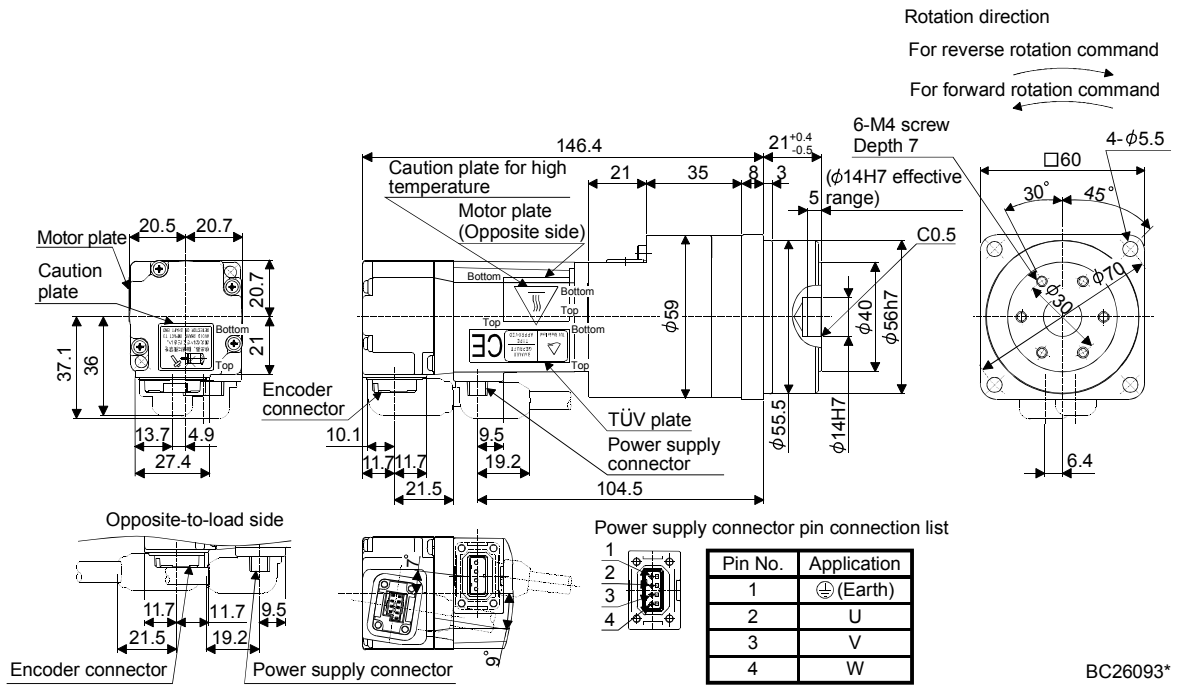

BC26093\*

## 6. HF-MP SERIES · HF-KP SERIES

Model	Output [W]	Reduction gear model	Reduction ratio	Inertia moment J [ $\times 10^{-4} \text{kg} \cdot \text{m}^2$ ] (WK <sup>2</sup> [oz · in <sup>2</sup> ])	Mass [kg] ([lb])
HF-MP13G5	100	HPG-20A-33-F0JMLAS-S	1/33	0.094 (0.514)	2.6 (5.73)
		HPG-20A-45-F0JMLAS-S	1/45	0.093 (0.508)	
HF-KP13G5	100	HPG-20A-33-F0JMLAS-S	1/33	0.150 (0.82)	2.6 (5.73)
		HPG-20A-45-F0JMLAS-S	1/45	0.149 (0.815)	

[Unit: mm]

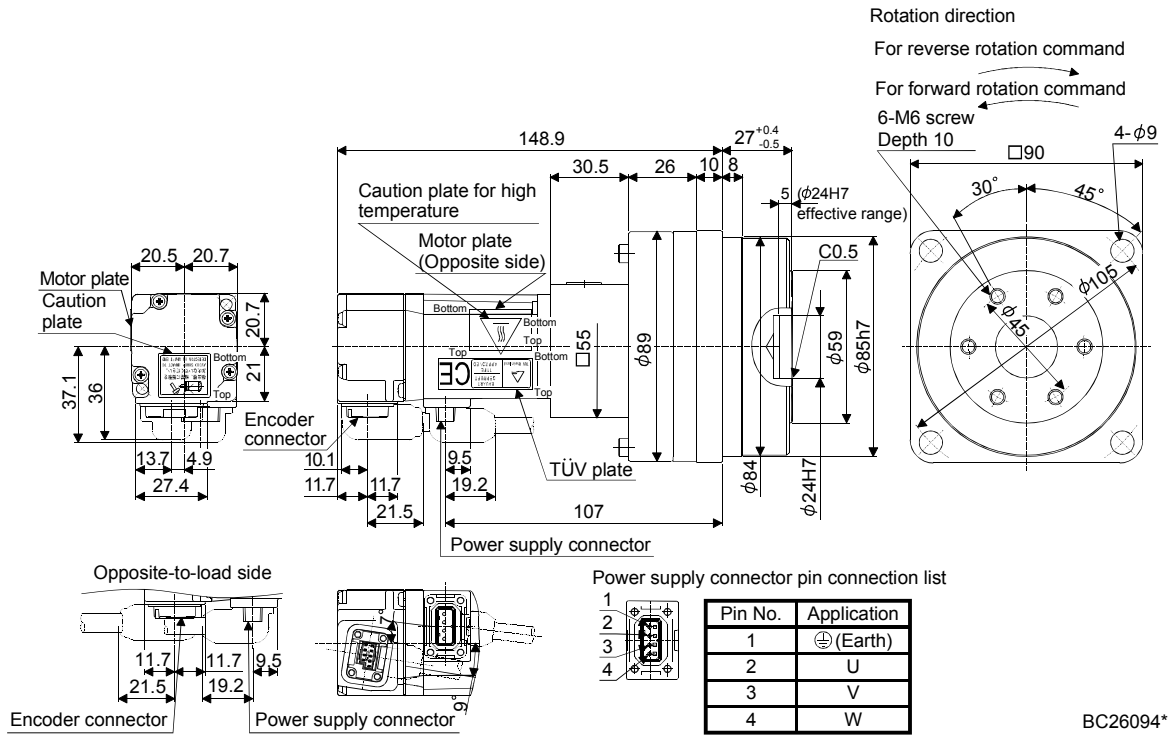

BC26094\*

## 6. HF-MP SERIES · HF-KP SERIES

Model	Output [W]	Reduction gear model	Reduction ratio	Inertia moment J [ $\times 10^{-4} \text{kg} \cdot \text{m}^2$ ] ( $\text{WK}^2 [\text{oz} \cdot \text{in}^2]$ )	Mass [kg] ([lb])
HF-MP23G5	200	HPG-14A-05-F0AZW-S	1/5	0.289 (1.58)	1.8 (3.97)
		HPG-14A-11-F0AZX-S	1/11	0.297 (1.59)	1.9 (4.19)
HF-KP23G5	200	HPG-14A-05-F0AZW-S	1/5	0.441 (2.41)	1.8 (3.97)
		HPG-14A-11-F0AZX-S	1/11	0.443 (2.42)	1.9 (4.19)

[Unit: mm]

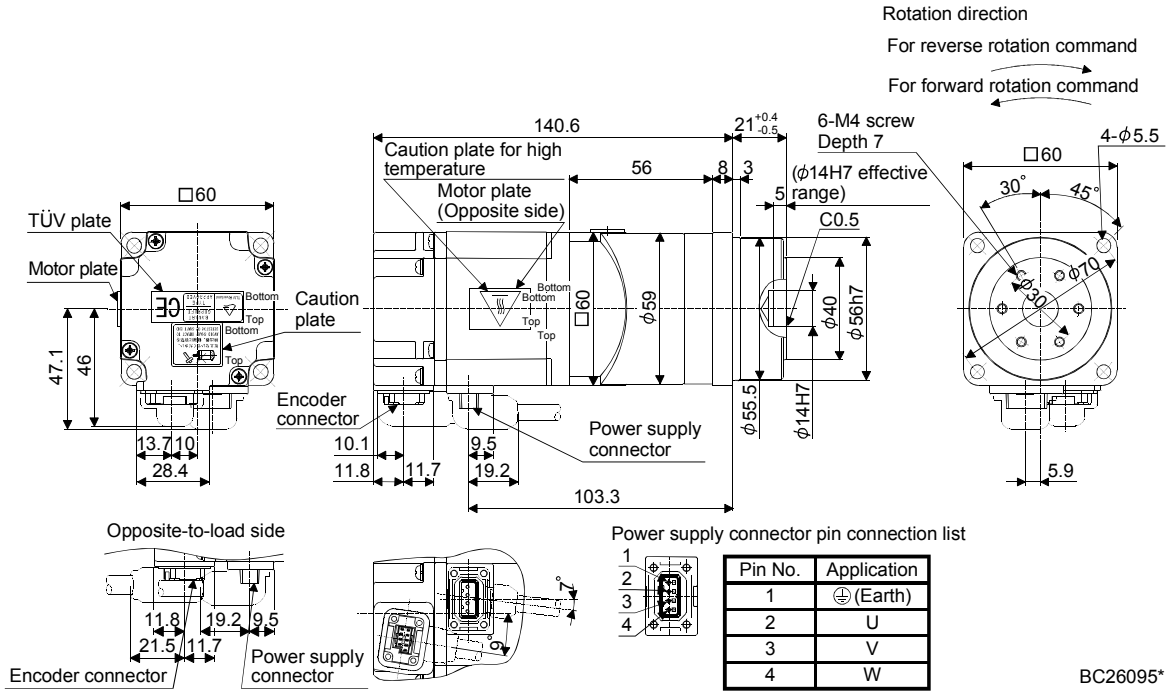

BC26095\*



## 6. HF-MP SERIES · HF-KP SERIES

Model	Output [W]	Reduction gear model	Reduction ratio	Inertia moment J [ $\times 10^{-4} \text{kg} \cdot \text{m}^2$ ] ( $\text{WK}^2 [\text{oz} \cdot \text{in}^2]$ )	Mass [kg] ([lb])
HF-MP23G5	200	HPG-20A-21-F0EKS-S	1/21	0.586 (3.20)	3.4 (7.50)
		HPG-20A-33-F0ELS-S	1/33	0.540 (2.95)	
		HPG-20A-45-F0FLS-S	1/45	0.539 (2.95)	
HF-KP23G5	200	HPG-20A-21-F0EKS-S	1/21	0.738 (4.04)	3.4 (7.50)
		HPG-20A-33-F0ELS-S	1/33	0.692 (3.78)	
		HPG-20A-45-F0FLS-S	1/45	0.691 (3.78)	

[Unit: mm]

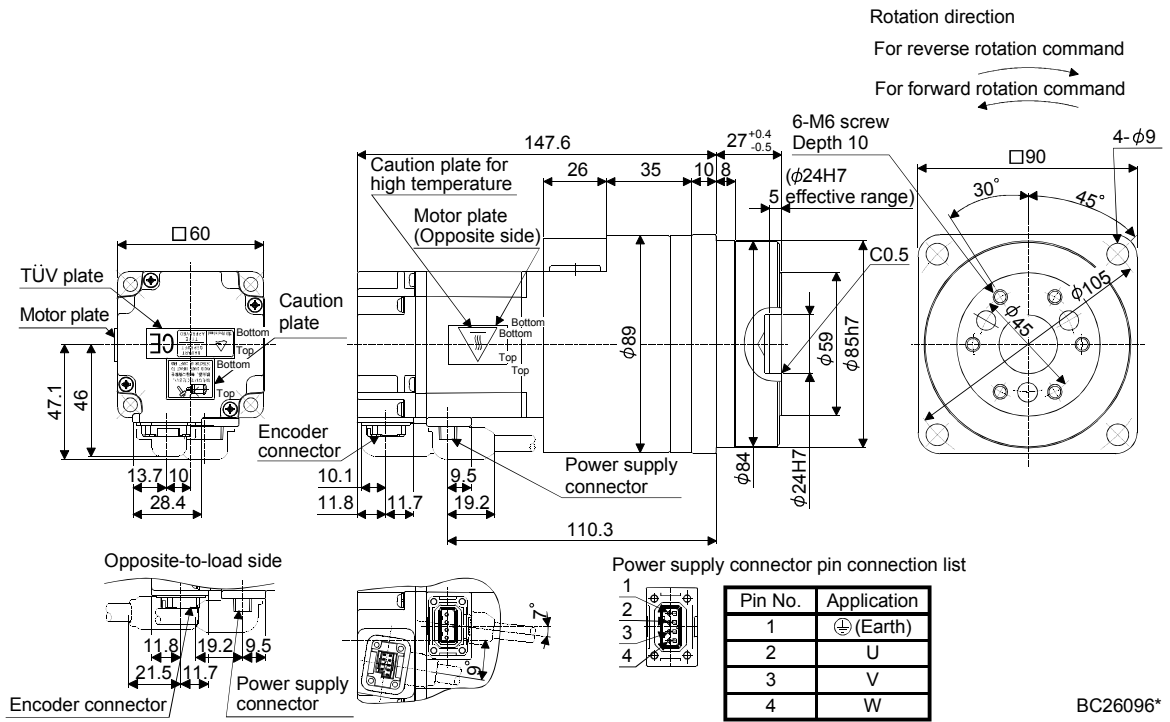

BC26096\*

## 6. HF-MP SERIES · HF-KP SERIES

Model	Output [W]	Reduction gear model	Reduction ratio	Inertia moment $J [\times 10^{-4} \text{kg} \cdot \text{m}^2] (\text{WK}^2 [\text{oz} \cdot \text{in}^2])$	Mass [kg] ([lb])
HF-MP43G5	400	HPG-14A-05-F0AZW-S	1/5	0.351 (1.92)	2.3 (5.07)
HF-KP43G5	400	HPG-14A-05-F0AZW-S	1/5	0.621 (3.40)	2.3 (5.07)

[Unit: mm]

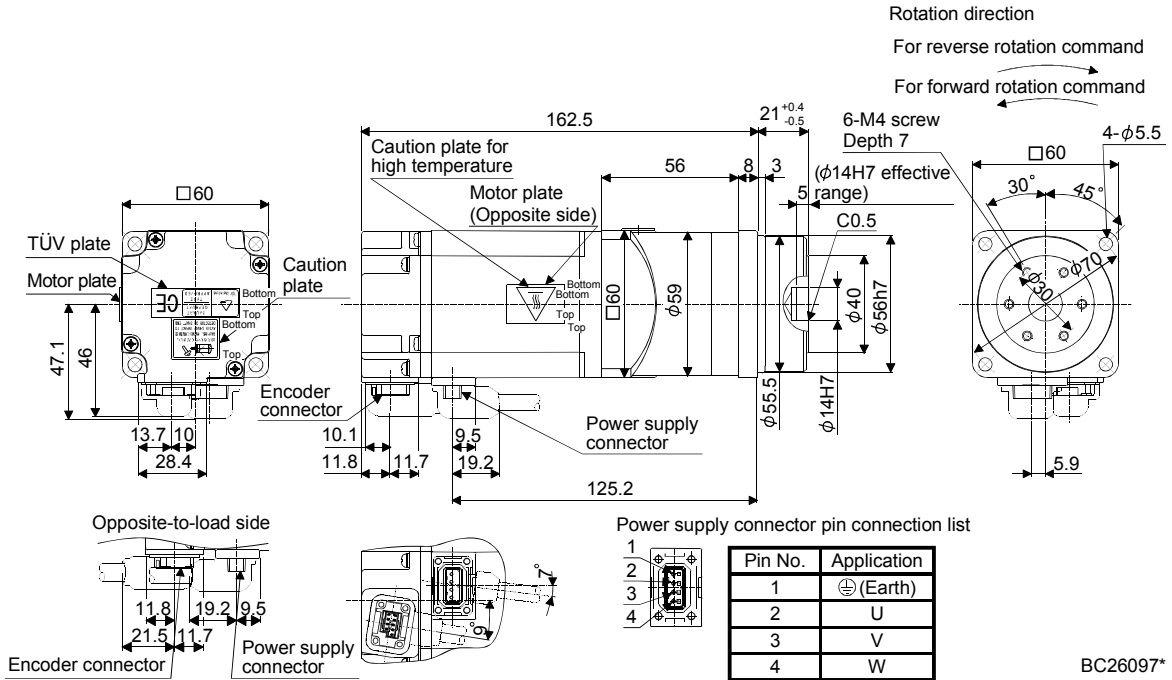

Model	Output [W]	Reduction gear model	Reduction ratio	Inertia moment $J [\times 10^{-4} \text{kg} \cdot \text{m}^2] (\text{WK}^2 [\text{oz} \cdot \text{in}^2])$	Mass [kg] ([lb])
HF-MP43G5	400	HPG-20A-11-F0EKS-S	1/11	0.726 (3.97)	4.0 (8.82)
		HPG-20A-21-F0EKS-S	1/21	0.648 (3.54)	
HF-KP43G5	400	HPG-20A-11-F0EKS-S	1/11	0.996 (5.45)	4.0 (8.82)
		HPG-20A-21-F0EKS-S	1/21	0.918 (5.02)	

[Unit: mm]

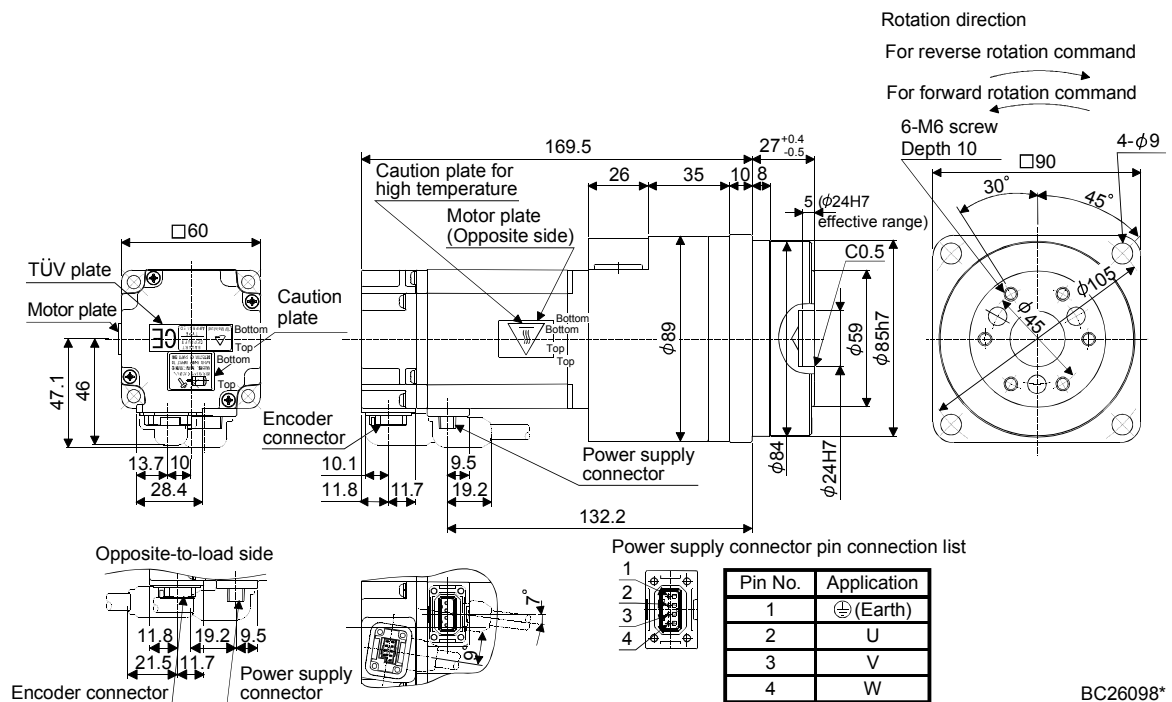

## 6. HF-MP SERIES · HF-KP SERIES

Model	Output [W]	Reduction gear model	Reduction ratio	Inertia moment J [ $\times 10^{-4} \text{kg} \cdot \text{m}^2$ ] (WK <sup>2</sup> [oz · in <sup>2</sup> ])	Mass [kg] ([lb])
HF-MP43G5	400	HPG-32A-33-F0RLAS-S	1/33	0.700 (3.83)	6.1 (13.4)
		HPG-32A-45-F0RLAS-S	1/45	0.694 (3.79)	
HF-KP43G5	400	HPG-32A-33-F0RLAS-S	1/33	0.970 (5.30)	6.1 (13.4)
		HPG-32A-45-F0RLAS-S	1/45	0.964 (5.27)	

[Unit: mm]

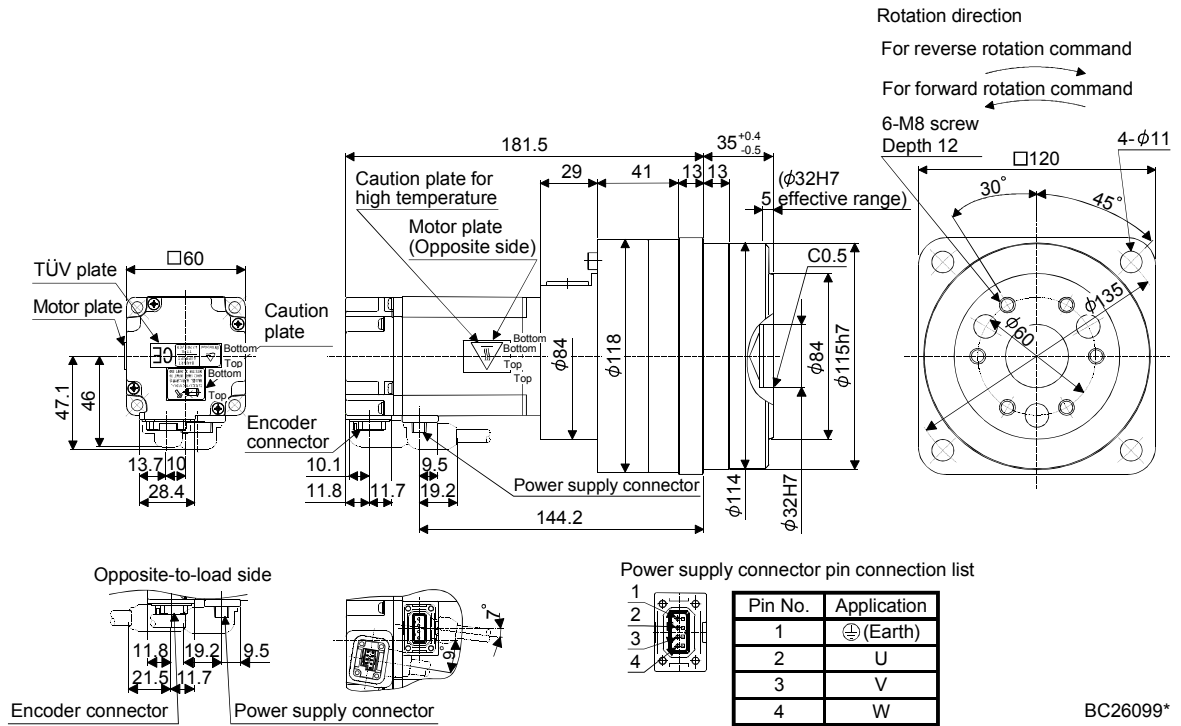

BC26099\*

## 6. HF-MP SERIES · HF-KP SERIES

Model	Output [W]	Reduction gear model	Reduction ratio	Inertia moment J [ $\times 10^{-4} \text{kg} \cdot \text{m}^2$ ] ( $\text{WK}^2$ [oz · in <sup>2</sup> ])	Mass [kg] ([lb])
HF-MP73G5	750	HPG-20A-05-F0FEOS-S	1/5	1.25 (6.84)	4.9 (10.8)
		HPG-20A-11-F0FEPS-S	1/11	1.16 (6.34)	5.2 (11.5)
HF-KP73G5	750	HPG-20A-05-F0FEOS-S	1/5	2.08 (11.4)	4.9 (10.8)
		HPG-20A-11-F0FEPS-S	1/11	1.99 (10.9)	5.2 (11.5)

[Unit: mm]

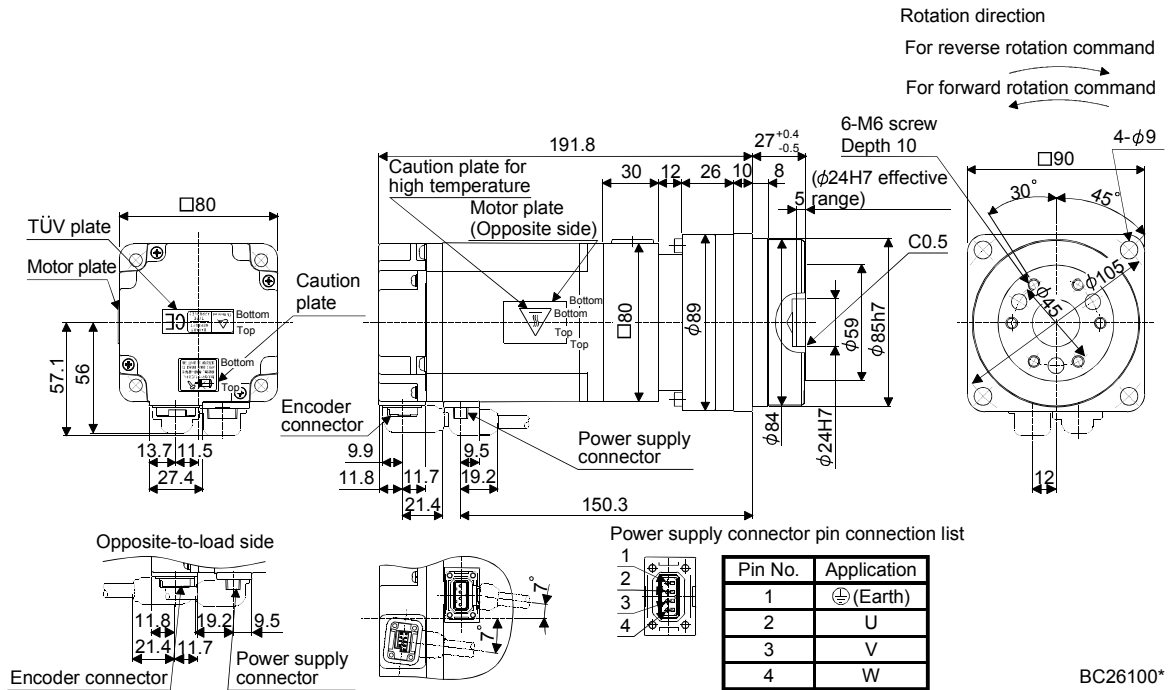

## 6. HF-MP SERIES · HF-KP SERIES

Model	Output [W]	Reduction gear model	Reduction ratio	Inertia moment J [ $\times 10^{-4} \text{kg} \cdot \text{m}^2$ ] ( $\text{WK}^2$ [oz · in <sup>2</sup> ])	Mass [kg] ([lb])
HF-MP73G5	750	HPG-32A-21-F0SEIS-S	1/21	1.35 (7.38)	7.3 (16.1)
		HPG-32A-33-F0SEJS-S	1/33	1.13 (6.18)	
		HPG-32A-45-F0SEJS-S	1/45	1.13 (6.18)	
HF-KP73G5	750	HPG-32A-21-F0SEIS-S	1/21	2.18 (11.9)	7.3 (16.1)
		HPG-32A-33-F0SEJS-S	1/33	1.96 (10.7)	
		HPG-32A-45-F0SEJS-S	1/45	1.96 (10.7)	

[Unit: mm]

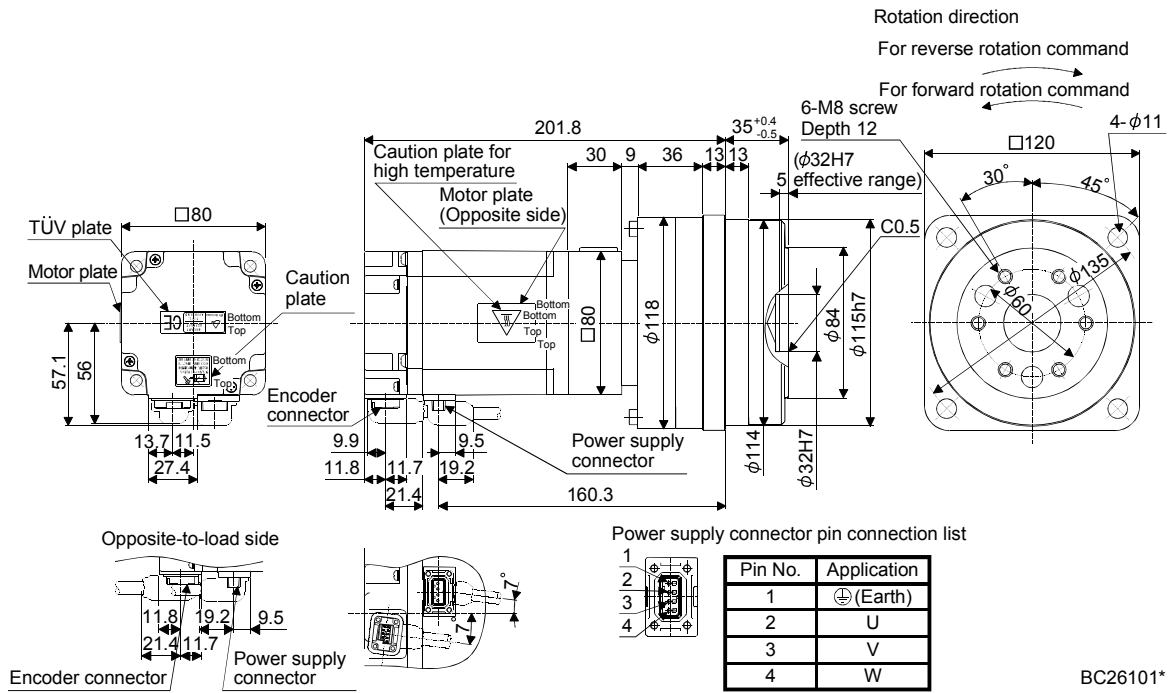

BC26101\*

## 6. HF-MP SERIES · HF-KP SERIES

### 6.8.6 For precision application with flange mounting, flange output type reduction gear (with an electromagnetic brake)

Model	Output [W]	Brake static friction torque [N · m] (oz · in)	Reduction gear model	Reduction ratio	Inertia moment $J$ [ $\times 10^{-4}$ kg · m <sup>2</sup> ] (WK <sup>2</sup> [oz · in <sup>2</sup> ])	Mass [kg] (lb)
HF-MP053BG5	50	0.32 (45.3)	HPG-14A-05-F0CBJS-S	1/5	0.093 (0.508)	1.4 (3.09)
			HPG-14A-11-F0CBKS-S	1/11	0.085 (0.465)	1.5 (3.31)
			HPG-14A-21-F0CBKS-S	1/21	0.076 (0.416)	
			HPG-14A-33-F0CBLS-S	1/33	0.070 (0.383)	
			HPG-14A-45-F0CBLS-S	1/45	0.070 (0.383)	
HF-KP053BG5	50	0.32 (45.3)	HPG-14A-05-F0CBJS-S	1/5	0.122 (0.667)	1.4 (3.09)
			HPG-14A-11-F0CBKS-S	1/11	0.114 (0.623)	1.5 (3.31)
			HPG-14A-21-F0CBKS-S	1/21	0.105 (0.574)	
			HPG-14A-33-F0CBLS-S	1/33	0.099 (0.541)	
			HPG-14A-45-F0CBLS-S	1/45	0.099 (0.541)	

[Unit: mm]

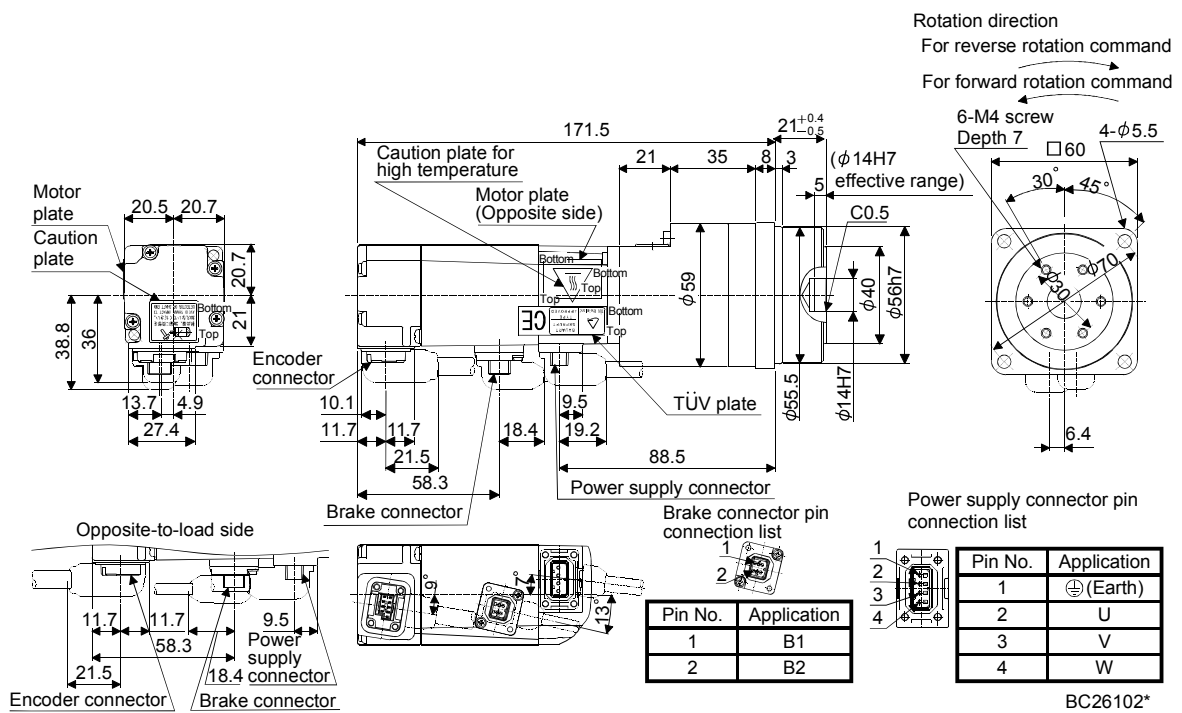

## 6. HF-MP SERIES · HF-KP SERIES

Model	Output [W]	Brake static friction torque [N · m] (oz · in)	Reduction gear model	Reduction ratio	Inertia moment J [ $\times 10^{-4}$ kg · m <sup>2</sup> ] (WK <sup>2</sup> [oz · in <sup>2</sup> ])	Mass [kg] (lb)
HF-MP13BG5	100	0.32 (45.3)	HPG-14A-05-F0CBJS-S	1/5	0.107 (0.585)	1.6 (3.53)
			HPG-14A-11-F0CBKS-S	1/11	0.099 (0.541)	1.7 (3.75)
			HPG-14A-21-F0CBKS-S	1/21	0.090 (0.492)	1.7 (3.75)
HF-KP13BG5	100	0.32 (45.3)	HPG-14A-05-F0CBJS-S	1/5	0.158 (0.864)	1.6 (3.53)
			HPG-14A-11-F0CBKS-S	1/11	0.150 (0.82)	1.7 (3.75)
			HPG-14A-21-F0CBKS-S	1/21	0.141 (0.771)	1.7 (3.75)

[Unit: mm]

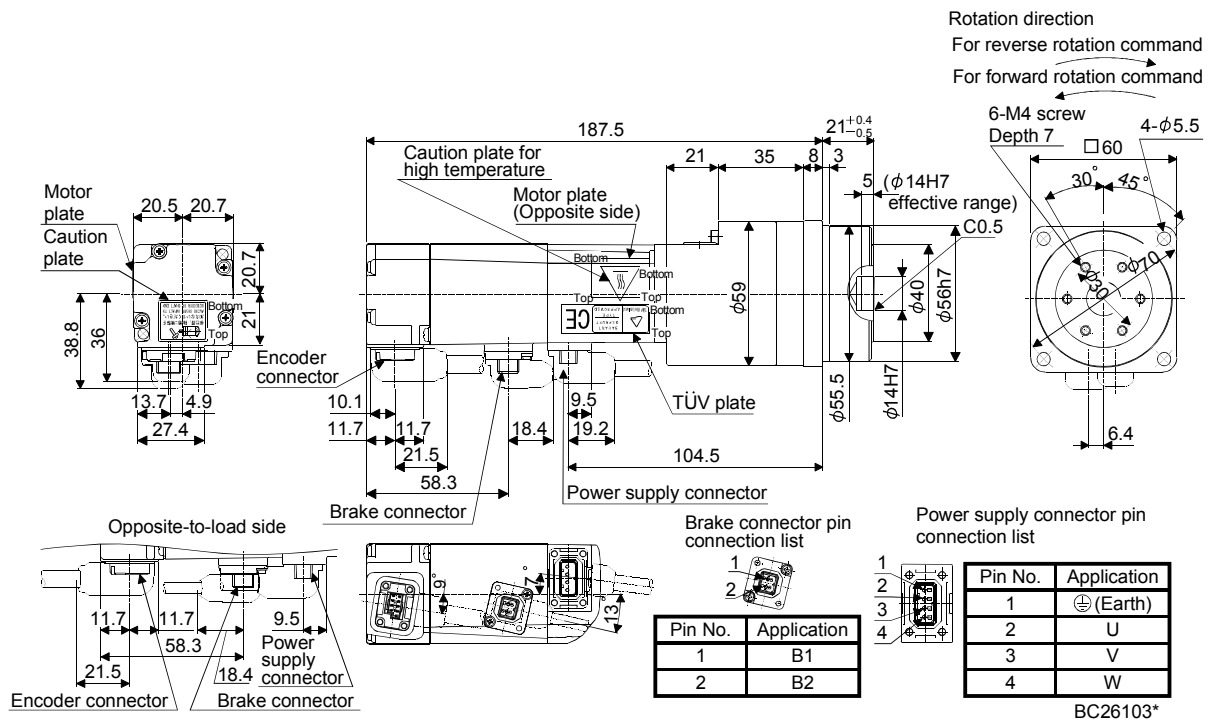

## 6. HF-MP SERIES · HF-KP SERIES

Model	Output [W]	Brake static friction torque [N · m] (oz · in)	Reduction gear model	Reduction ratio	Inertia moment J [ $\times 10^{-4}$ kg · m <sup>2</sup> ] (WK <sup>2</sup> [oz · in <sup>2</sup> ])	Mass [kg] (lb)
HF-MP13BG5	100	0.32 (45.3)	HPG-20A-33-F0JMLAS-S	1/33	0.101 (0.552)	2.9 (6.39)
			HPG-20A-45-F0JMLAS-S	1/45	0.100 (0.547)	
HF-KP13BG5	100	0.32 (45.3)	HPG-20A-33-F0JMLAS-S	1/33	0.152 (0.831)	2.9 (6.39)
			HPG-20A-45-F0JMLAS-S	1/45	0.151 (0.826)	

[Unit: mm]

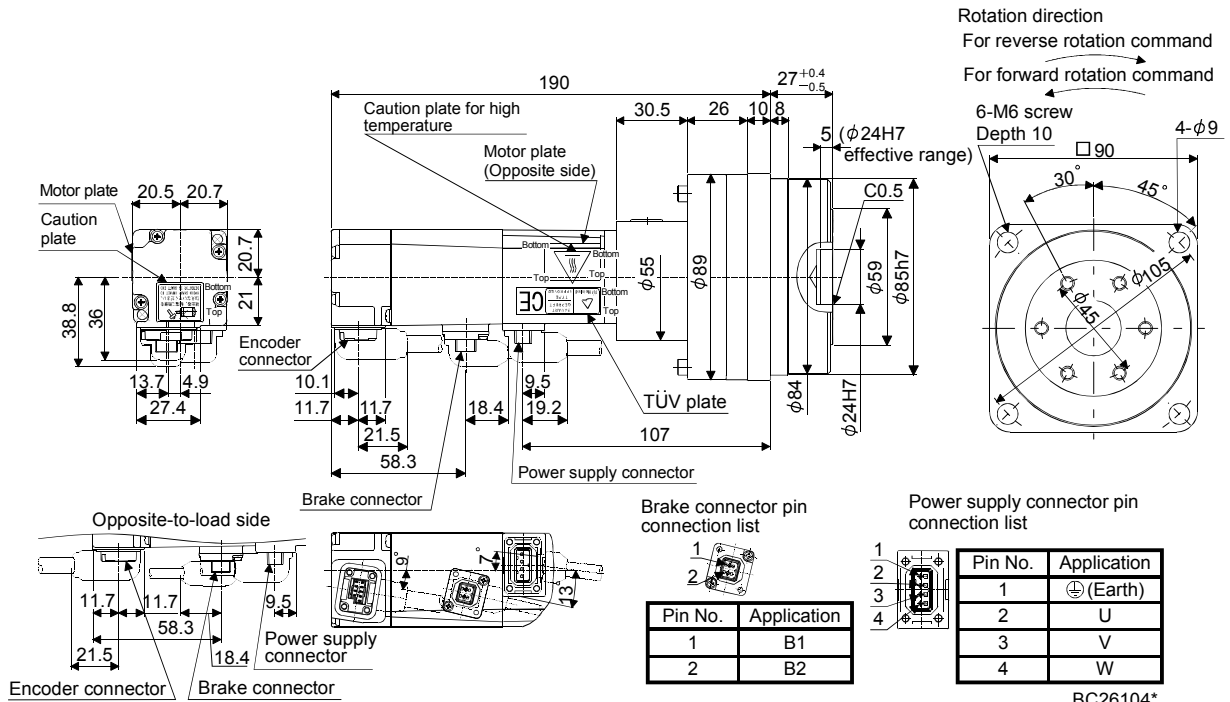



## 6. HF-MP SERIES · HF-KP SERIES

Model	Output [W]	Brake static friction torque [N · m] (oz · in)	Reduction gear model	Reduction ratio	Inertia moment J [ $\times 10^{-4}$ kg · m <sup>2</sup> ] (WK <sup>2</sup> [oz · in <sup>2</sup> ])	Mass [kg] (lb)
HF-MP23BG5	200	1.3 (184)	HPG-14A-05-F0AZW-S	1/5	0.321 (1.76)	2.4 (5.29)
			HPG-14A-11-F0AZX-S	1/11	0.323 (1.77)	2.5 (5.51)
HF-KP23BG5	200	1.3 (184)	HPG-14A-05-F0AZW-S	1/5	0.511 (2.79)	2.4 (5.29)
			HPG-14A-11-F0AZX-S	1/11	0.513 (2.81)	2.5 (5.51)

[Unit: mm]

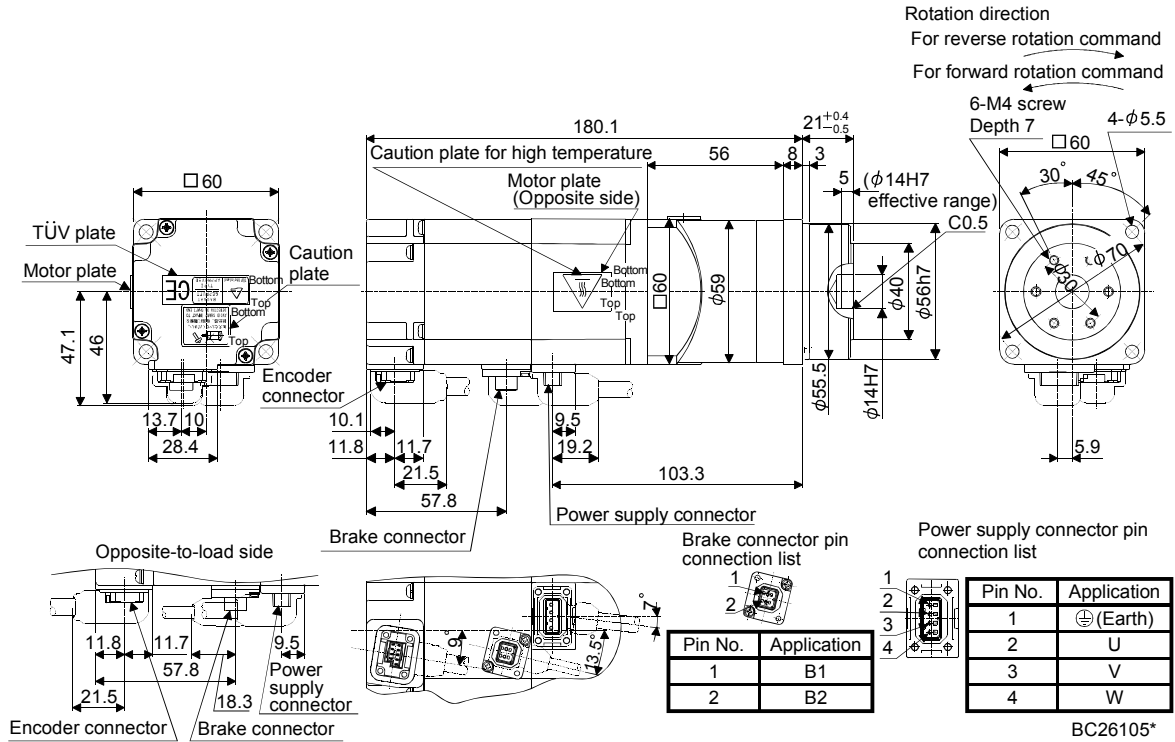

## 6. HF-MP SERIES · HF-KP SERIES

Model	Output [W]	Brake static friction torque [N · m] ((oz · in))	Reduction gear model	Reduction ratio	Inertia moment J [ $\times 10^{-4}$ kg · m <sup>2</sup> ] (WK <sup>2</sup> [oz · in <sup>2</sup> ])	Mass [kg] ((lb))
HF-MP23BG5	200	1.3 (184)	HPG-20A-21-F0EKS-S	1/21	0.618 (3.38)	4.1 (9.04)
			HPG-20A-33-F0ELS-S	1/33	0.572 (3.18)	
			HPG-20A-45-F0ELS-S	1/45	0.571 (3.12)	
HF-KP23BG5	200	1.3 (184)	HPG-20A-21-F0EKS-S	1/21	0.808 (4.42)	4.1 (9.04)
			HPG-20A-33-F0ELS-S	1/33	0.762 (4.17)	
			HPG-20A-45-F0ELS-S	1/45	0.761 (4.16)	

[Unit: mm]

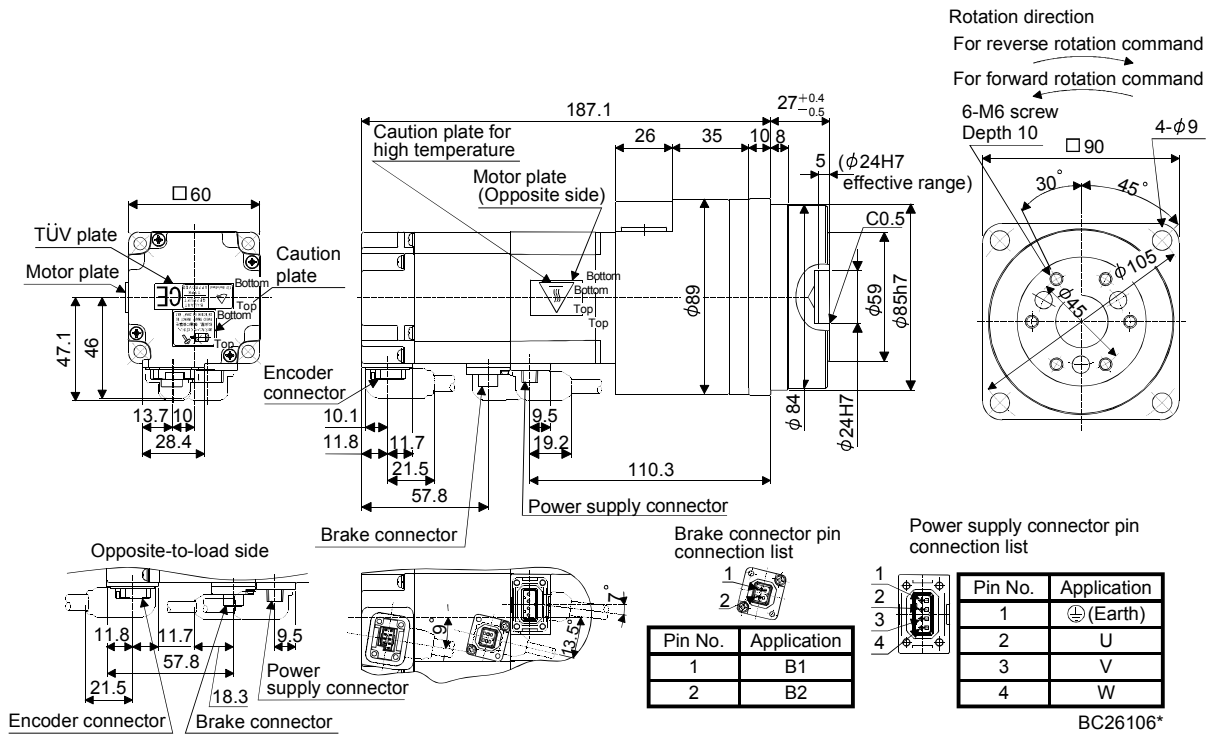

## 6. HF-MP SERIES · HF-KP SERIES

Model	Output [W]	Brake static friction torque [N · m] (oz · in)	Reduction gear model	Reduction ratio	Inertia moment J [ $\times 10^{-4}$ kg · m <sup>2</sup> ] (WK <sup>2</sup> [oz · in <sup>2</sup> ])	Mass [kg] (lb)
HF-MP43BG5	400	1.3 (184)	HPG-14A-05-F0AZSW-S	1/5	0.381 (2.08)	2.9 (6.39)
HF-KP43BG5	400	1.3 (184)	HPG-14A-05-F0AZSW-S	1/5	0.701 (3.83)	2.9 (6.39)

[Unit: mm]

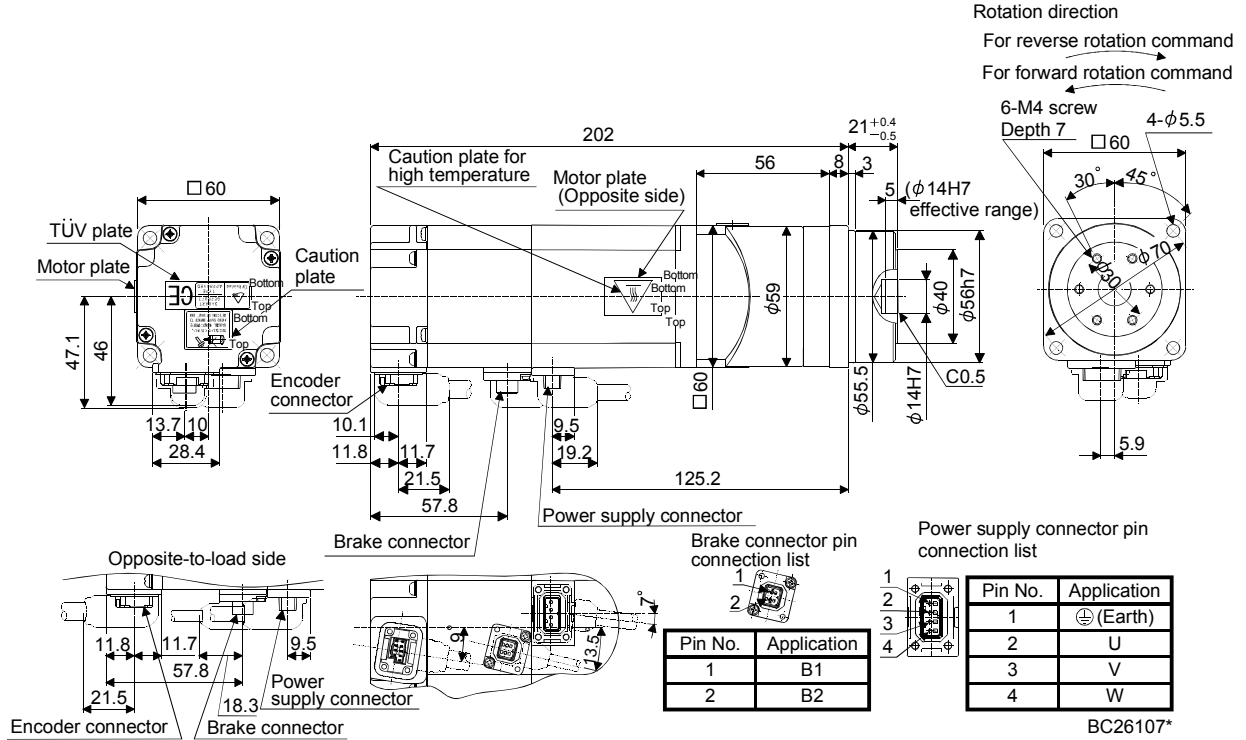

## 6. HF-MP SERIES · HF-KP SERIES

Model	Output [W]	Brake static friction torque [N · m] (oz · in)	Reduction gear model	Reduction ratio	Inertia moment J [ $\times 10^{-4}$ kg · m <sup>2</sup> ] (WK <sup>2</sup> [oz · in <sup>2</sup> ])	Mass [kg] (lb)
HF-MP43BG5	400	1.3 (184)	HPG-20A-11-F0EKS-S	1/11	0.756 (4.13)	4.6 (10.1)
			HPG-20A-21-F0EKS-S	1/21	0.678 (3.71)	
HF-KP43BG5	400	1.3 (184)	HPG-20A-11-F0EKS-S	1/11	1.08 (5.91)	4.6 (10.1)
			HPG-20A-21-F0EKS-S	1/21	0.998 (5.46)	

[Unit: mm]

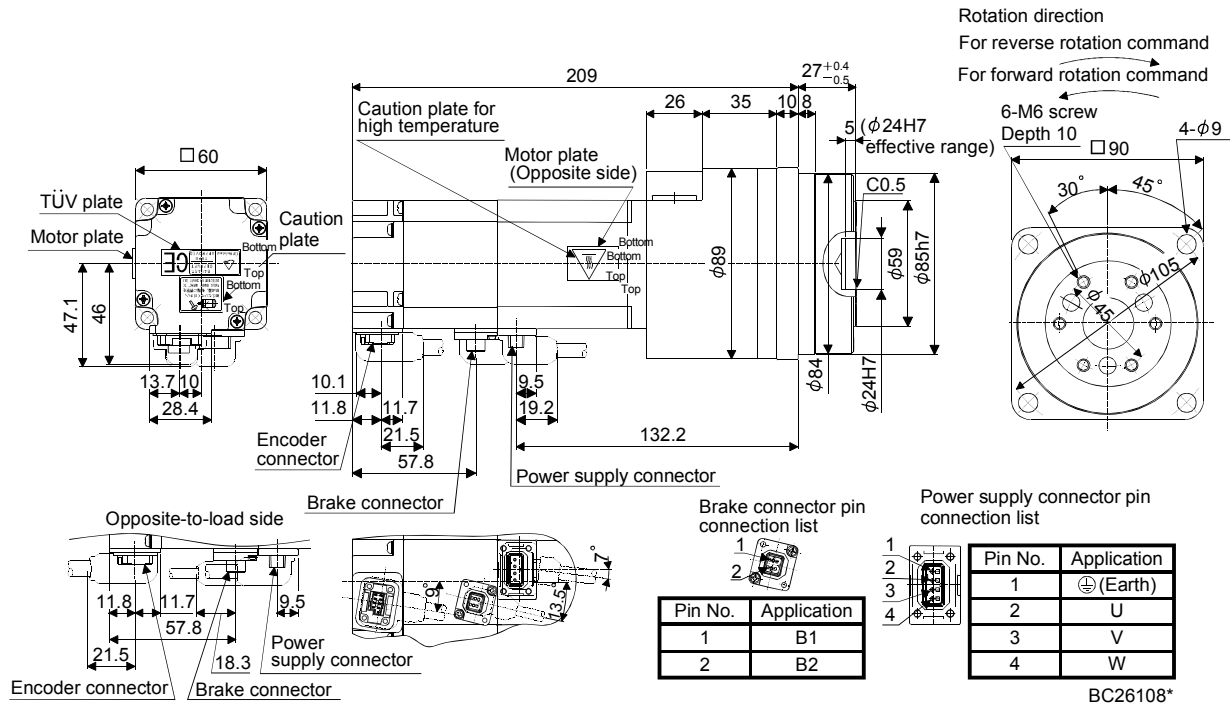

## 6. HF-MP SERIES · HF-KP SERIES

Model	Output [W]	Brake static friction torque [N · m] (oz · in)	Reduction gear model	Reduction ratio	Inertia moment J [ $\times 10^{-4}$ kg · m <sup>2</sup> ] (WK <sup>2</sup> [oz · in <sup>2</sup> ])	Mass [kg] ([lb])
HF-MP43BG5	400	1.3 (184)	HPG-32A-33-F0RLAS-S	1/33	0.730 (3.99)	6.7 (14.8)
			HPG-32A-45-F0RLAS-S	1/45	0.724 (3.94)	
HF-KP43BG5	400	1.3 (184)	HPG-32A-33-F0RLAS-S	1/33	1.05 (5.74)	6.7 (14.8)
			HPG-32A-45-F0RLAS-S	1/45	1.04 (5.69)	

[Unit: mm]

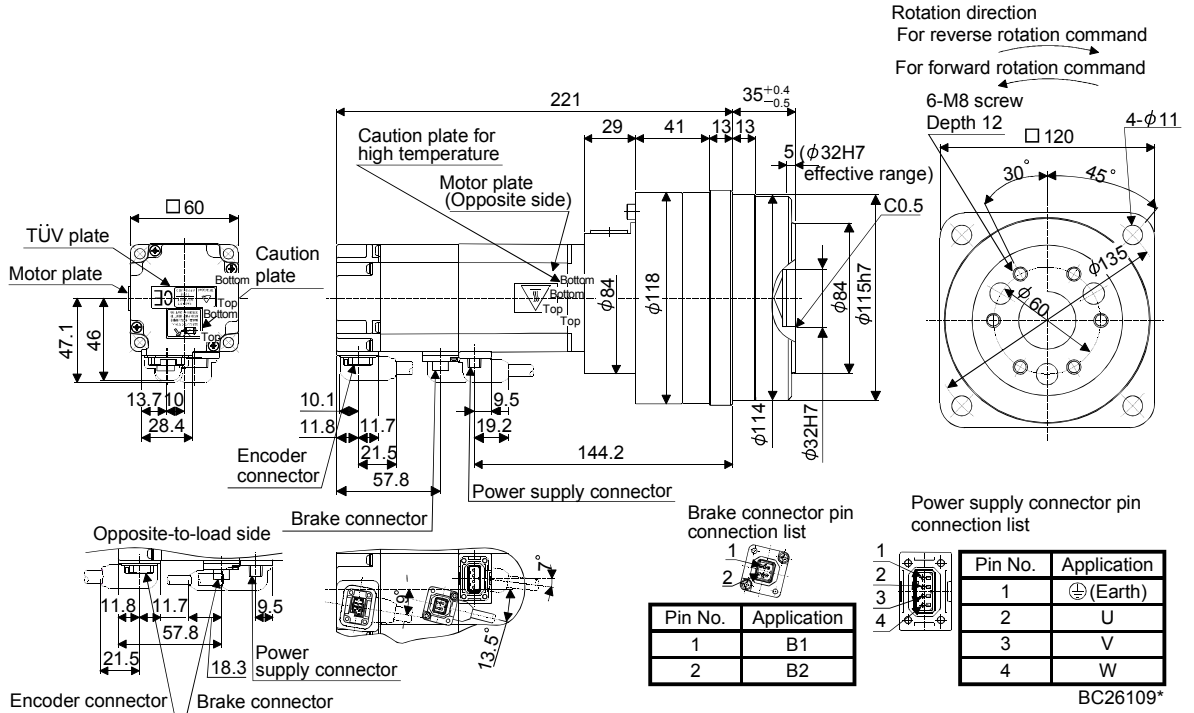

## 6. HF-MP SERIES · HF-KP SERIES

Model	Output [W]	Brake static friction torque [N · m] (oz · in)	Reduction gear model	Reduction ratio	Inertia moment J [ $\times 10^{-4}$ kg · m <sup>2</sup> ] (WK <sup>2</sup> [oz · in <sup>2</sup> ])	Mass [kg] (lb)
HF-MP73BG5	750	2.4 (340)	HPG-20A-05-F0FEOS-S	1/5	1.35 (7.38)	5.9 (13.0)
			HPG-20A-11-F0FEPS-S	1/11	1.26 (6.89)	6.2 (13.7)
HF-KP73BG5	750	2.4 (340)	HPG-20A-05-F0FEOS-S	1/5	2.28 (12.5)	5.9 (13.0)
			HPG-20A-11-F0FEPS-S	1/11	2.19 (12.0)	6.2 (13.7)

[Unit: mm]

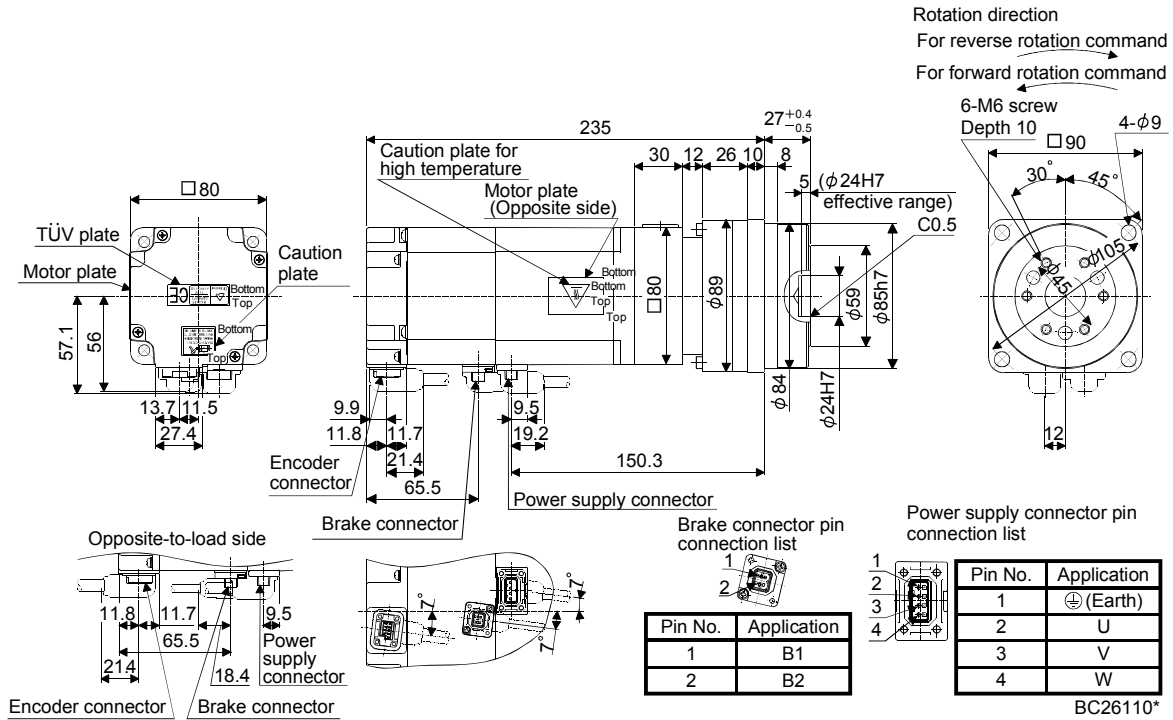

## 6. HF-MP SERIES · HF-KP SERIES

Model	Output [W]	Brake static friction torque [N · m] (oz · in)	Reduction gear model	Reduction ratio	Inertia moment J [ $\times 10^{-4} \text{kg} \cdot \text{m}^2$ ] ( $\text{WK}^2$ [oz · in <sup>2</sup> ])	Mass [kg] (lb)
HF-MP73BG5	750	2.4 (340)	HPG-32A-21-F0SEIS-S	1/21	1.45 (7.93)	8.3 (18.3)
			HPG-32A-33-F0SEJS-S	1/33	1.23 (6.73)	
			HPG-32A-45-F0SEJS-S	1/45	1.23 (6.73)	
HF-KP73BG5	750	2.4 (340)	HPG-32A-21-F0SEIS-S	1/21	2.38 (13.0)	8.3 (18.3)
			HPG-32A-33-F0SEJS-S	1/33	2.16 (11.8)	
			HPG-32A-45-F0SEJS-S	1/45	2.16 (11.8)	

[Unit: mm]

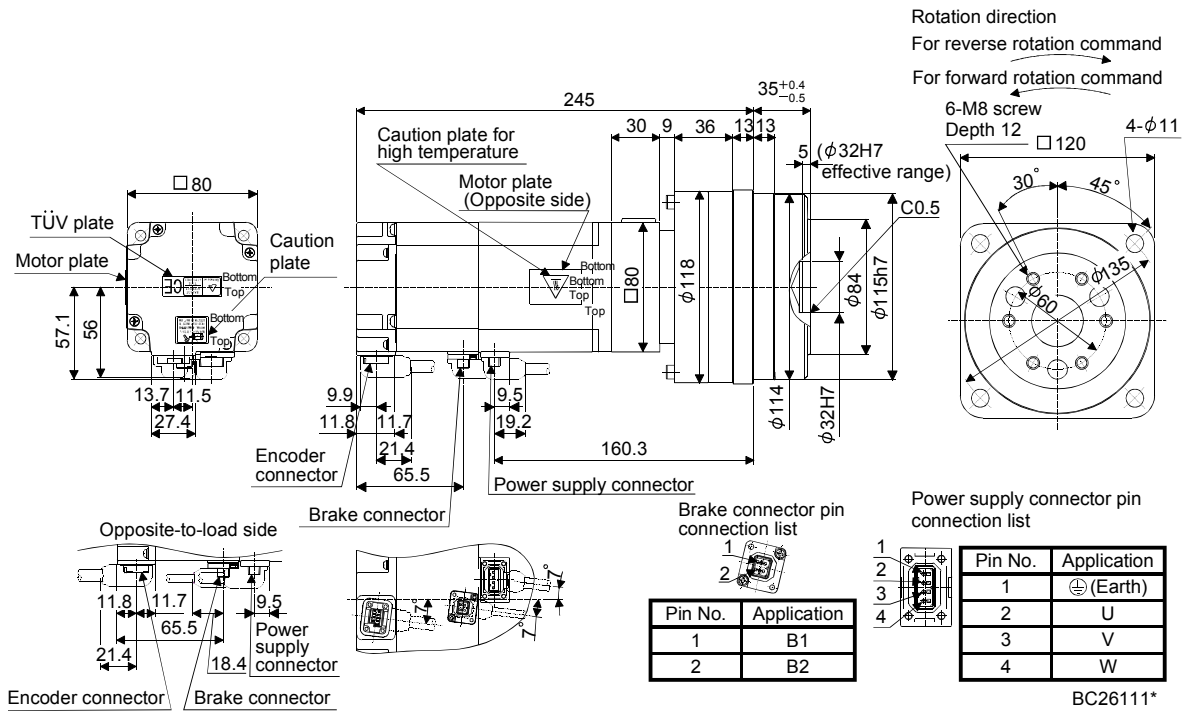

## 6. HF-MP SERIES · HF-KP SERIES

6.8.7 For precision application with flange mounting, shaft output type reduction gear (without an electromagnetic brake)

Model	Output [W]	Reduction gear model	Reduction ratio	Inertia moment J [ $\times 10^{-4} \text{kg} \cdot \text{m}^2$ ] ( $\text{WK}^2 [\text{oz} \cdot \text{in}^2]$ )	Mass [kg] ([lb])
HF-MP053G7	50	HPG-14A-05-J2CBJS-S	1/5	0.093 (0.508)	1.2 (2.65)
		HPG-14A-11-J2CBKS-S	1/11	0.080 (0.437)	
		HPG-14A-21-J2CBKS-S	1/21	0.070 (0.383)	
		HPG-14A-33-J2CBLS-S	1/33	0.064 (0.35)	
		HPG-14A-45-J2CBLS-S	1/45	0.064 (0.35)	
HF-KP053G7	50	HPG-14A-05-J2CBJS-S	1/5	0.126 (0.689)	1.2 (2.65)
		HPG-14A-11-J2CBKS-S	1/11	0.113 (0.618)	
		HPG-14A-21-J2CBKS-S	1/21	0.103 (0.563)	
		HPG-14A-33-J2CBLS-S	1/33	0.097 (0.53)	
		HPG-14A-45-J2CBLS-S	1/45	0.097 (0.53)	

[Unit: mm]

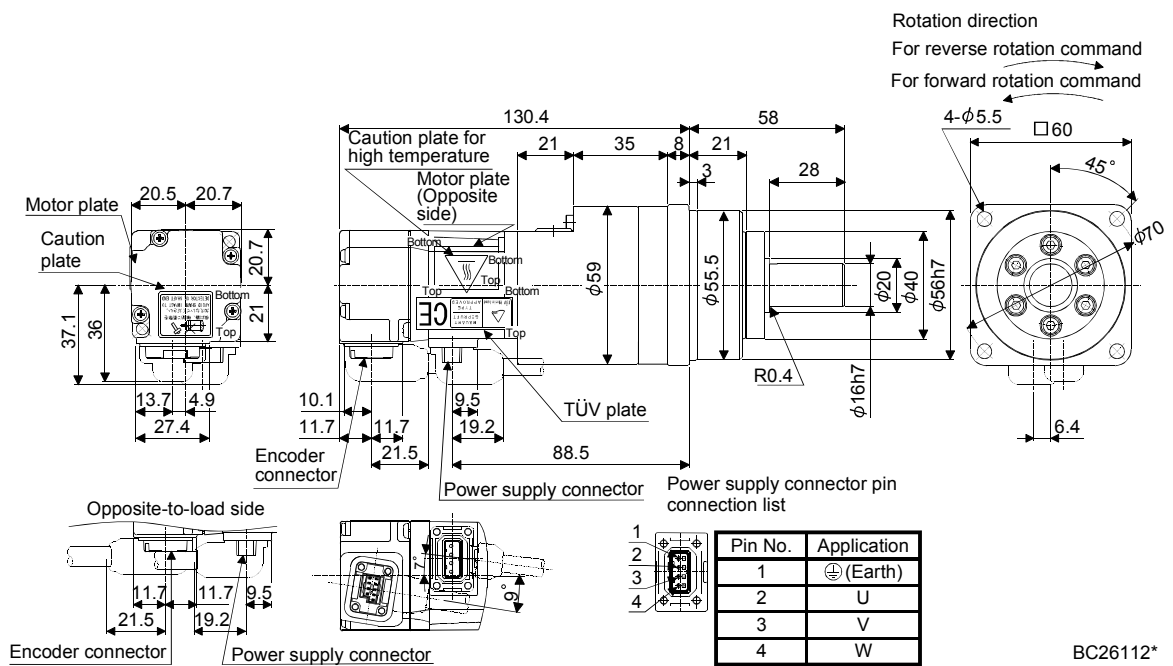



## 6. HF-MP SERIES · HF-KP SERIES

Model	Output [W]	Reduction gear model	Reduction ratio	Inertia moment J [ $\times 10^{-4} \text{kg} \cdot \text{m}^2$ ] ( $\text{WK}^2$ [oz · in <sup>2</sup> ])	Mass [kg] ([lb])
HF-MP13G7	100	HPG-14A-05-J2CBJS-S	1/5	0.106 (0.58)	1.4 (3.09)
		HPG-14A-11-J2CBKS-S	1/11	0.093 (0.508)	1.5 (3.31)
		HPG-14A-21-J2CBKS-S	1/21	0.083 (0.454)	1.5 (3.31)
HF-KP13G7	100	HPG-14A-05-J2CBJS-S	1/5	0.162 (0.886)	1.4 (3.09)
		HPG-14A-11-J2CBKS-S	1/11	0.149 (0.815)	1.5 (3.31)
		HPG-14A-21-J2CBKS-S	1/21	0.139 (0.76)	1.5 (3.31)

[Unit: mm]

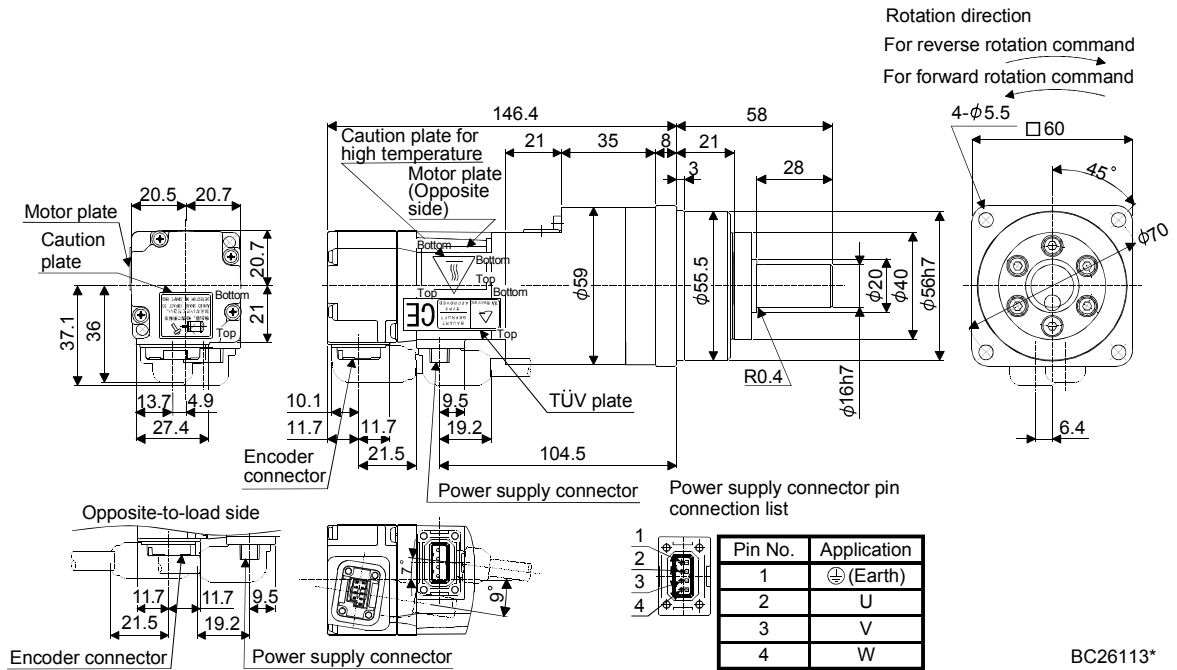

## 6. HF-MP SERIES · HF-KP SERIES

Model	Output [W]	Reduction gear model	Reduction ratio	Inertia moment J [ $\times 10^{-4} \text{kg} \cdot \text{m}^2$ ] ( $\text{WK}^2$ [oz · in <sup>2</sup> ])	Mass [kg] ([lb])
HF-MP13G7	100	HPG-20A-33-J2JMLAS-S	1/33	0.095 (0.519)	3.0 (6.61)
		HPG-20A-45-J2JMLAS-S	1/45	0.093 (0.508)	
HF-KP13G7	100	HPG-20A-33-J2JMLAS-S	1/33	0.151 (0.826)	3.0 (6.61)
		HPG-20A-45-J2JMLAS-S	1/45	0.149 (0.815)	

[Unit: mm]

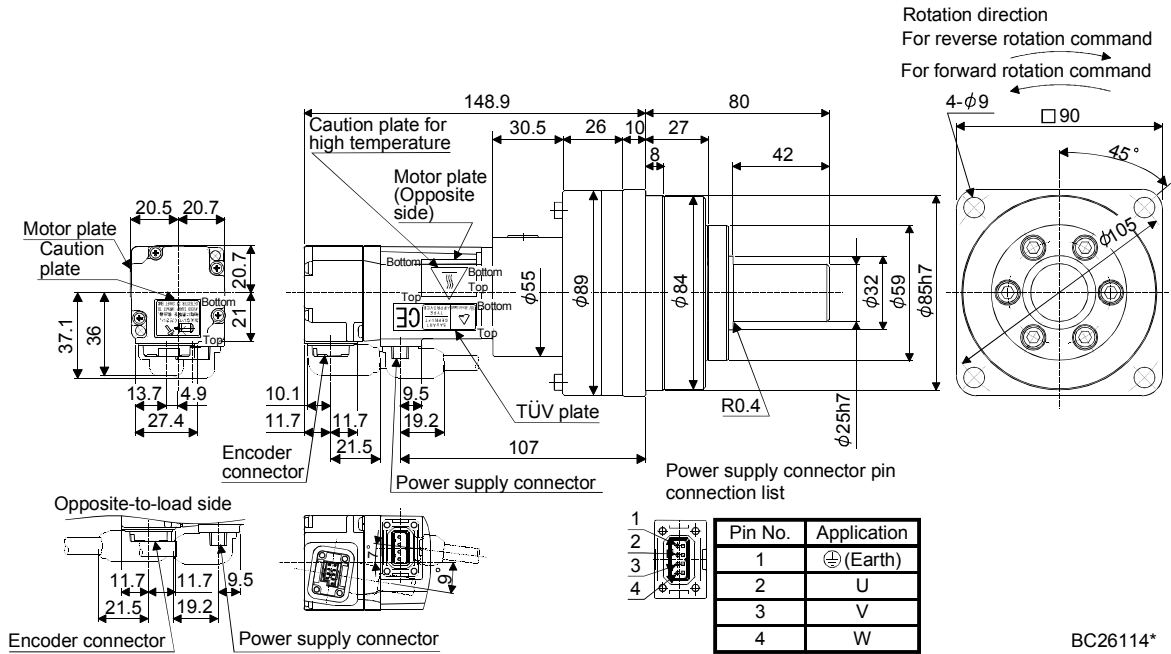

BC26114\*

## 6. HF-MP SERIES · HF-KP SERIES

Model	Output [W]	Reduction gear model	Reduction ratio	Inertia moment J [ $\times 10^{-4}$ kg · m <sup>2</sup> ] (WK <sup>2</sup> [oz · in <sup>2</sup> ])	Mass [kg] ([lb])
HF-MP23G7	200	HPG-14A-05-J2AZW-S	1/5	0.295 (1.61)	1.9 (4.19)
		HPG-14A-11-J2AZX-S	1/11	0.291 (1.59)	2.0 (4.41)
HF-KP23G7	200	HPG-14A-05-J2AZW-S	1/5	0.447 (2.44)	1.9 (4.19)
		HPG-14A-11-J2AZX-S	1/11	0.443 (2.42)	2.0 (4.41)

[Unit: mm]

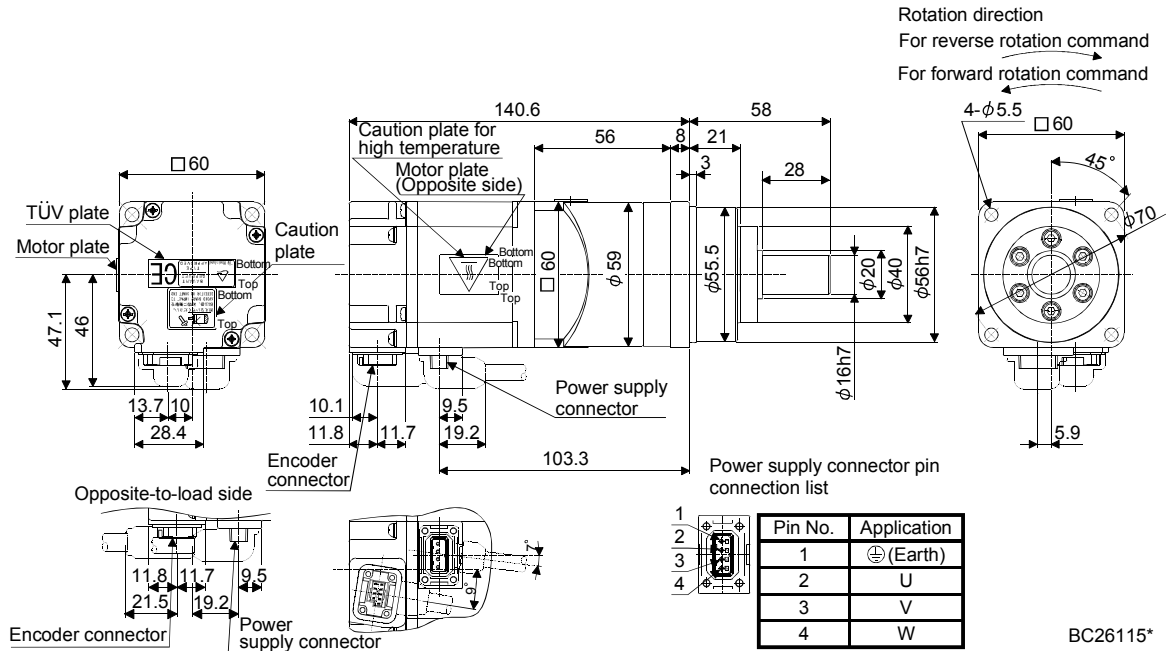

BC26115\*

## 6. HF-MP SERIES · HF-KP SERIES

Model	Output [W]	Reduction gear model	Reduction ratio	Inertia moment J [ $\times 10^{-4} \text{kg} \cdot \text{m}^2$ ] (WK <sup>2</sup> [oz · in <sup>2</sup> ])	Mass [kg] ([lb])
HF-MP23G7	200	HPG-20A-21-J2EKS-S	1/21	0.588 (3.22)	3.8 (8.38)
		HPG-20A-33-J2ELS-S	1/33	0.541 (2.96)	
		HPG-20A-45-J2ELS-S	1/45	0.539 (2.95)	
HF-KP23G7	200	HPG-20A-21-J2EKS-S	1/21	0.740 (4.05)	3.8 (8.38)
		HPG-20A-33-J2ELS-S	1/33	0.693 (3.79)	
		HPG-20A-45-J2ELS-S	1/45	0.691 (3.78)	

[Unit: mm]

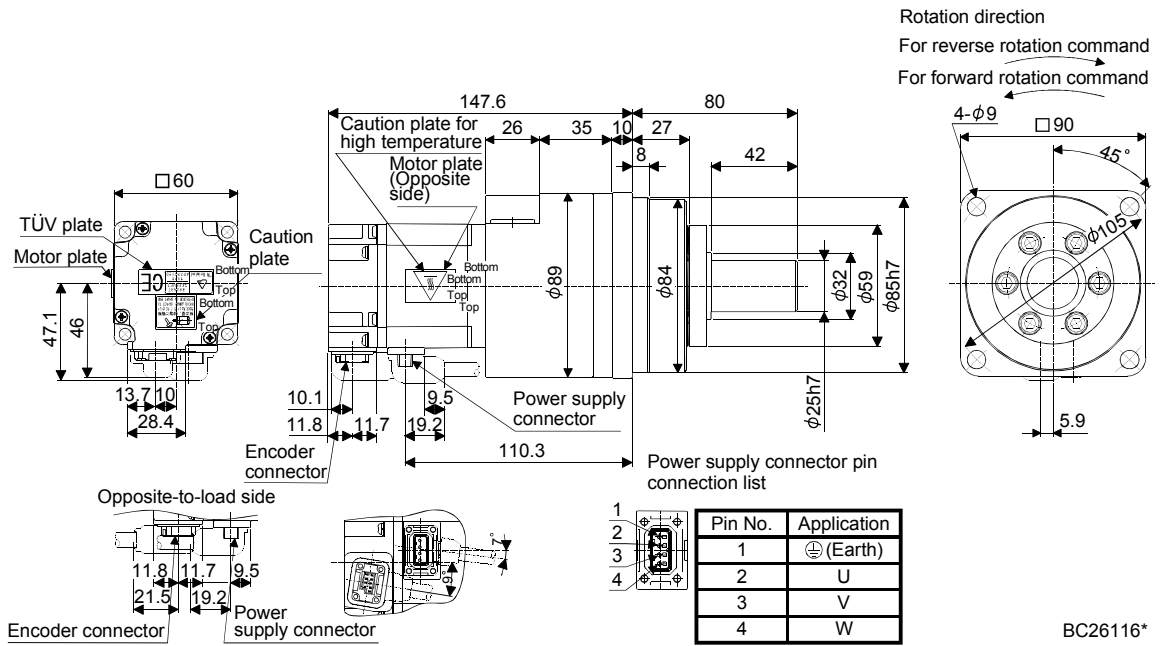

## 6. HF-MP SERIES · HF-KP SERIES

Model	Output [W]	Reduction gear model	Reduction ratio	Inertia moment $J [\times 10^{-4} \text{kg} \cdot \text{m}^2] (\text{WK}^2 [\text{oz} \cdot \text{in}^2])$	Mass [kg] ([lb])
HF-MP43G7	400	HPG-14A-05-J2AZW-S	1/5	0.357 (1.95)	2.4 (5.29)
HF-KP43G7	400	HPG-14A-05-J2AZW-S	1/5	0.627 (3.43)	2.4 (5.29)

[Unit: mm]

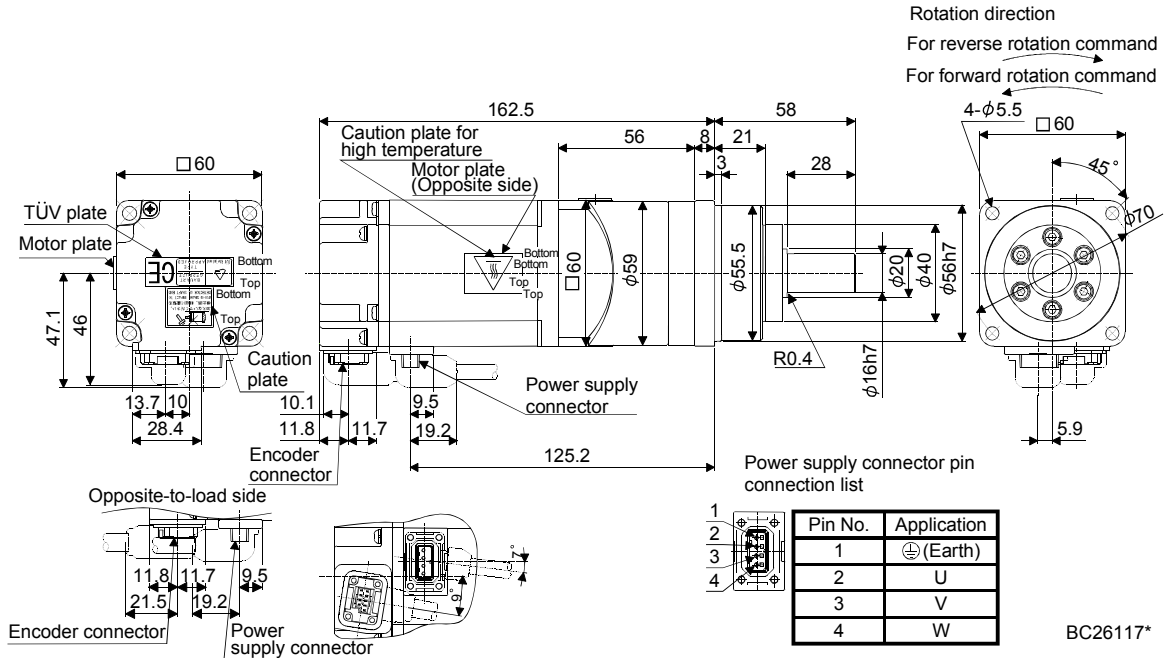

Model	Output [W]	Reduction gear model	Reduction ratio	Inertia moment $J [\times 10^{-4} \text{kg} \cdot \text{m}^2] (\text{WK}^2 [\text{oz} \cdot \text{in}^2])$	Mass [kg] ([lb])
HF-MP43G7	400	HPG-20A-11-J2EKS-S	1/11	0.734 (4.01)	4.4 (9.7)
		HPG-20A-21-J2EKS-S	1/21	0.650 (3.55)	
HF-KP43G7	400	HPG-20A-11-J2EKS-S	1/11	1.00 (5.47)	4.4 (9.7)
		HPG-20A-21-J2EKS-S	1/21	0.920 (5.03)	

[Unit: mm]

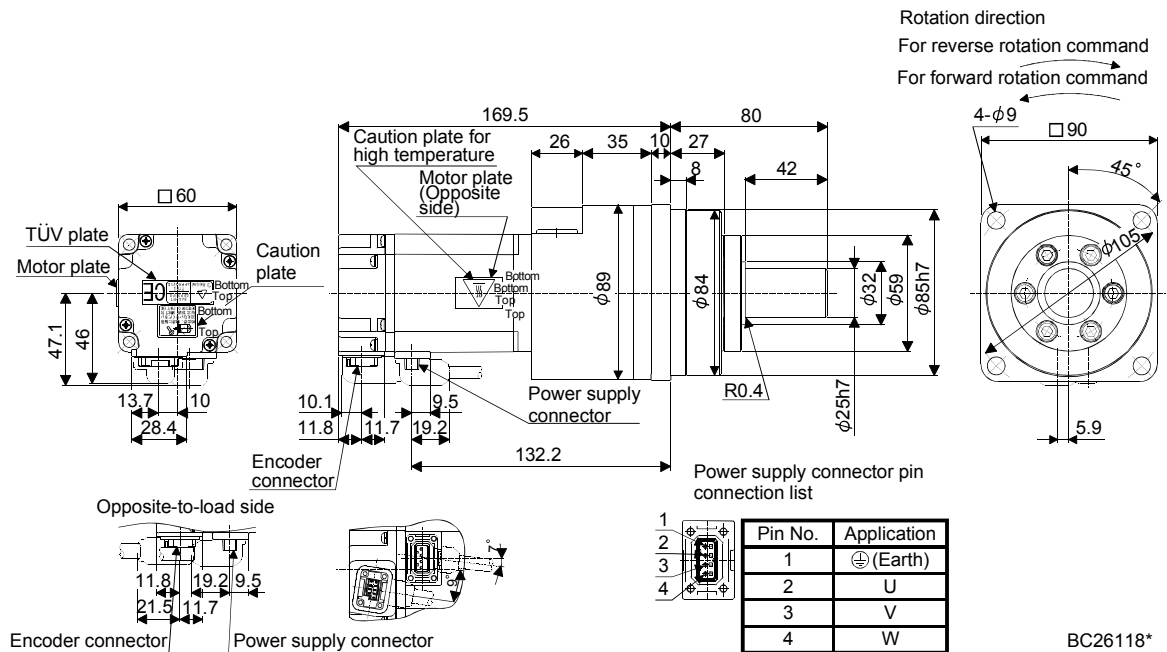

## 6. HF-MP SERIES · HF-KP SERIES

Model	Output [W]	Reduction gear model	Reduction ratio	Inertia moment $J [\times 10^{-4} \text{kg} \cdot \text{m}^2] (\text{WK}^2 [\text{oz} \cdot \text{in}^2])$	Mass [kg] (lb)
HF-MP43G7	400	HPG-32A-33-J2RLAS-S	1/33	0.706 (3.86)	7.5 (16.5)
		HPG-32A-45-J2RLAS-S	1/45	0.697 (3.81)	
HF-KP43G7	400	HPG-32A-33-J2RLAS-S	1/33	0.976 (5.34)	7.5 (16.5)
		HPG-32A-45-J2RLAS-S	1/45	0.967 (5.29)	

[Unit: mm]

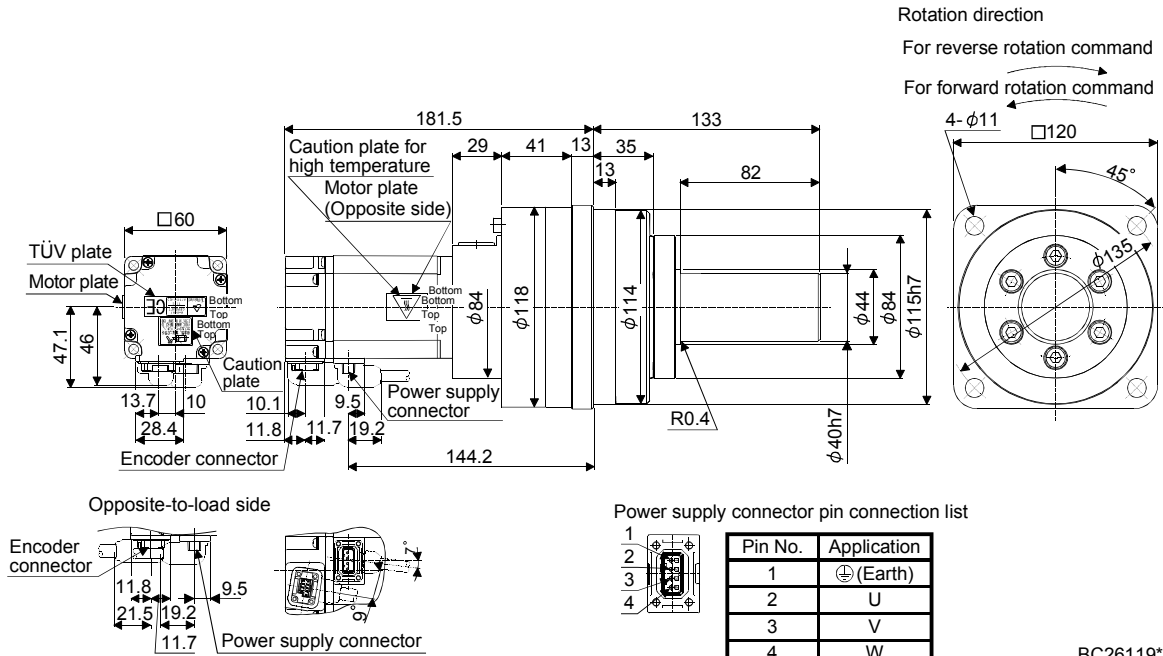

BC26119\*

Model	Output [W]	Reduction gear model	Reduction ratio	Inertia moment $J [\times 10^{-4} \text{kg} \cdot \text{m}^2] (\text{WK}^2 [\text{oz} \cdot \text{in}^2])$	Mass [kg] (lb)
HF-MP73G7	750	HPG-20A-05-J2FEOS-S	1/5	1.29 (7.0)	5.3 (11.7)
		HPG-20A-11-J2FEPS-S	1/11	1.17 (6.40)	5.6 (12.3)
HF-KP73G7	750	HPG-20A-05-J2FEOS-S	1/5	2.12 (11.6)	5.3 (11.7)
		HPG-20A-11-J2FEPS-S	1/11	2.00 (10.9)	5.6 (12.3)

[Unit: mm]

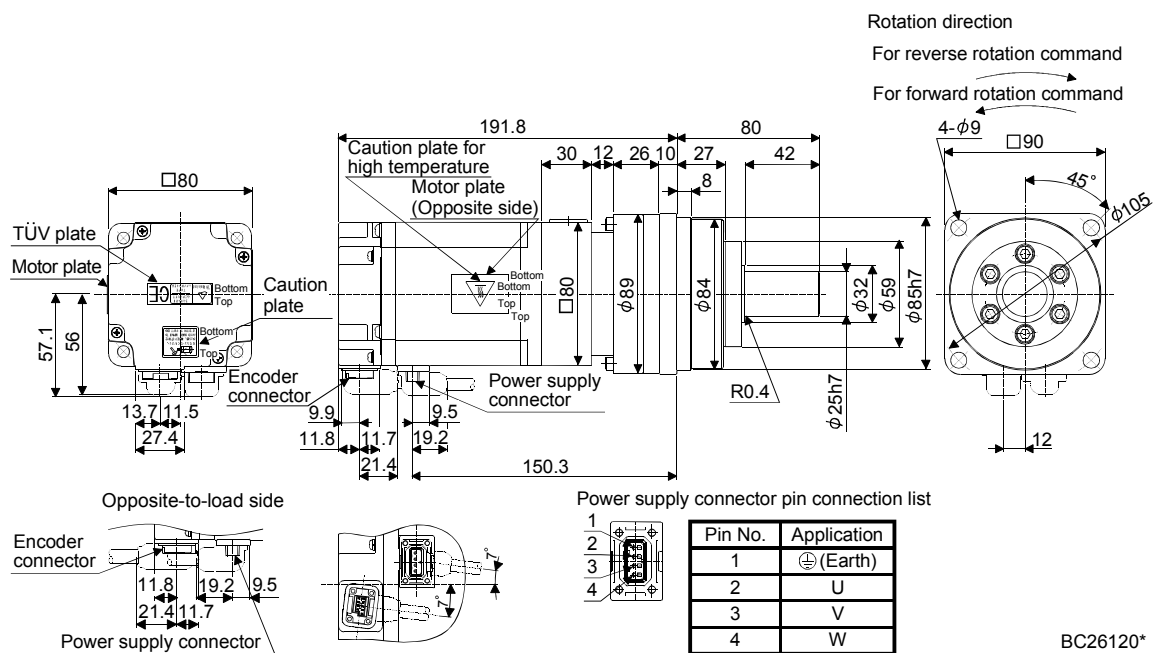

BC26120\*

## 6. HF-MP SERIES · HF-KP SERIES

Model	Output [W]	Reduction gear model	Reduction ratio	Inertia moment J [ $\times 10^{-4} \text{kg} \cdot \text{m}^2$ ] ( $\text{WK}^2$ [oz · in <sup>2</sup> ])	Mass [kg] ([lb])
HF-MP73G7	750	HPG-32A-21-J2SEIS-S	1/21	1.37 (7.49)	8.7 (19.2)
		HPG-32A-33-J2SEJS-S	1/33	1.14 (6.23)	
		HPG-32A-45-J2SEJS-S	1/45	1.13 (6.18)	
HF-KP73G7	750	HPG-32A-21-J2SEIS-S	1/21	2.20 (12.0)	8.7 (19.2)
		HPG-32A-33-J2SEJS-S	1/33	1.97 (10.8)	
		HPG-32A-45-J2SEJS-S	1/45	1.96 (10.7)	

[Unit: mm]

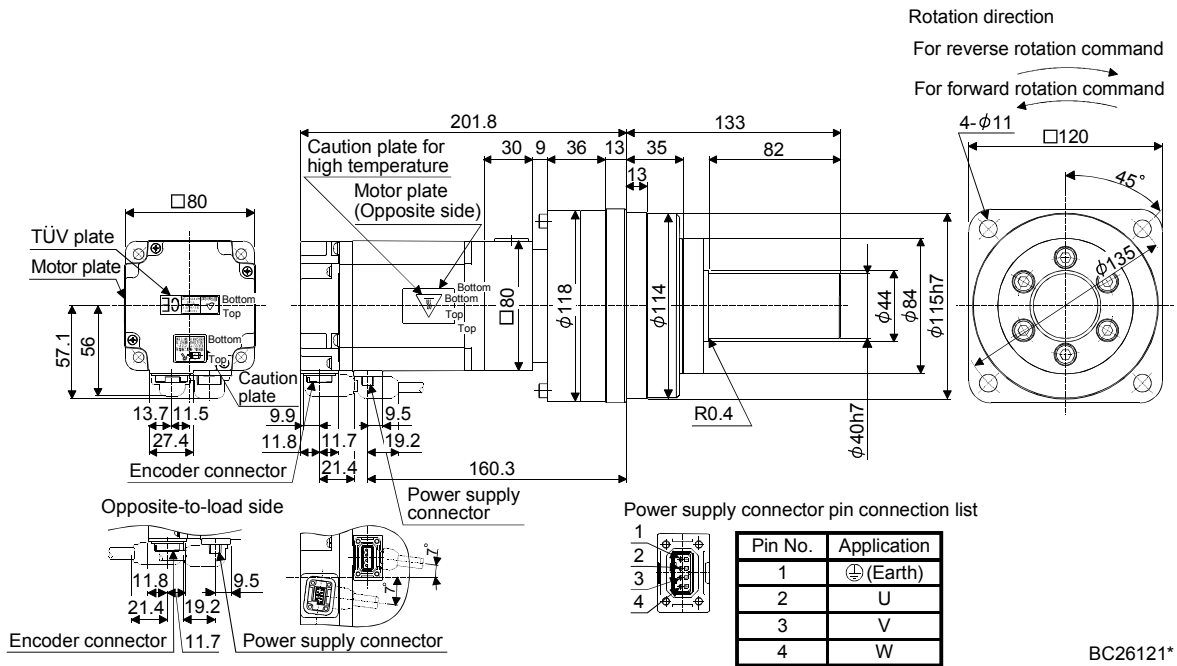

BC26121\*

## 6. HF-MP SERIES · HF-KP SERIES

### 6.8.8 For precision application with flange mounting, shaft output type reduction gear (with an electromagnetic brake)

Model	Output [W]	Brake static friction torque [N · m] ([oz · in])	Reduction gear model	Reduction ratio	Inertia moment J [ $\times 10^{-4} \text{kg} \cdot \text{m}^2$ ] ( $\text{WK}^2$ [oz · in <sup>2</sup> ])	Mass [kg] ([lb])
HF-MP053BG7	50	0.32 (45.3)	HPG-14A-05-J2CBJS-S	1/5	0.099 (0.541)	1.5 (3.31)
			HPG-14A-11-J2CBKS-S	1/11	0.086 (0.47)	1.6 (3.53)
			HPG-14A-21-J2CBKS-S	1/21	0.076 (0.416)	
			HPG-14A-33-J2CBLS-S	1/33	0.070 (0.383)	
			HPG-14A-45-J2CBLS-S	1/45	0.070 (0.383)	
HF-KP053BG7	50	0.32 (45.3)	HPG-14A-05-J2CBJS-S	1/5	0.128 (0.7)	1.5 (3.31)
			HPG-14A-11-J2CBKS-S	1/11	0.115 (0.629)	1.6 (3.53)
			HPG-14A-21-J2CBKS-S	1/21	0.105 (0.574)	
			HPG-14A-33-J2CBLS-S	1/33	0.099 (0.541)	
			HPG-14A-45-J2CBLS-S	1/45	0.099 (0.541)	

[Unit: mm]

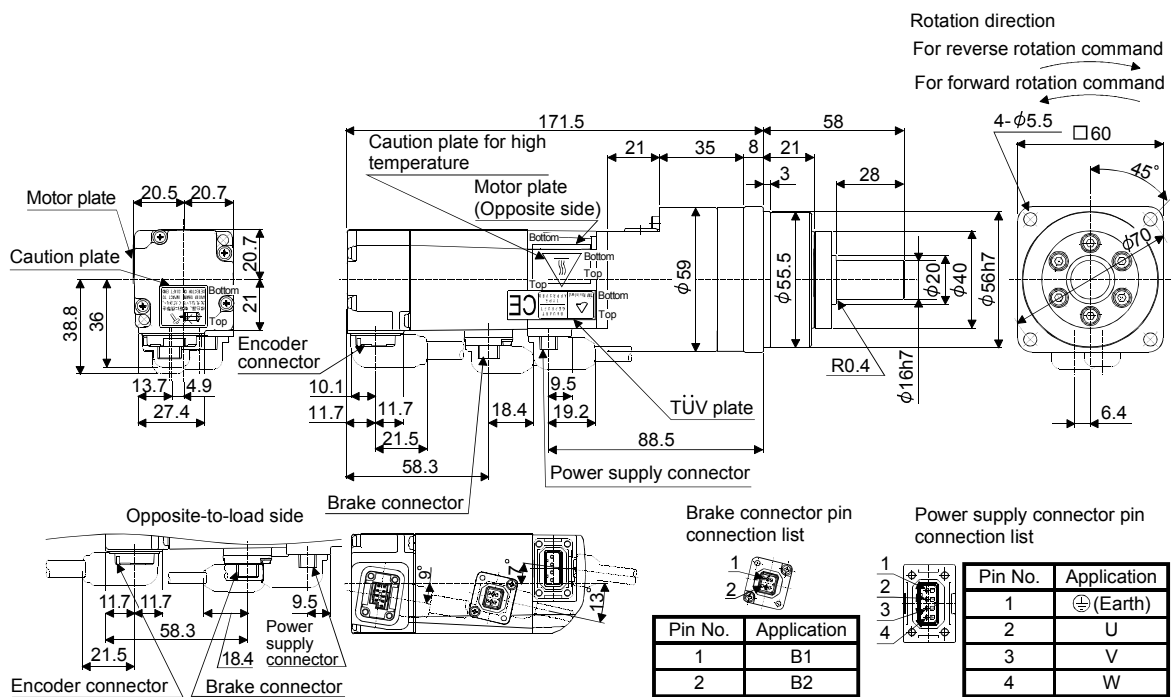

BC26122\*



## 6. HF-MP SERIES · HF-KP SERIES

Model	Output [W]	Brake static friction torque [N · m] (oz · in)	Reduction gear model	Reduction ratio	Inertia moment J [ $\times 10^{-4}$ kg · m <sup>2</sup> ] (WK <sup>2</sup> [oz · in <sup>2</sup> ])	Mass [kg] (lb)
HF-MP13BG7	100	0.32 (45.3)	HPG-14A-05-J2CBJS-S	1/5	0.113 (0.618)	1.7 (3.75)
			HPG-14A-11-J2CBKS-S	1/11	0.100 (0.547)	1.8 (3.97)
			HPG-14A-21-J2CBKS-S	1/21	0.090 (0.492)	1.8 (4.19)
HF-KP13BG7	100	0.32 (45.3)	HPG-14A-05-J2CBJS-S	1/5	0.164 (0.897)	1.7 (3.75)
			HPG-14A-11-J2CBKS-S	1/11	0.151 (0.826)	1.8 (3.97)
			HPG-14A-21-J2CBKS-S	1/21	0.141 (0.771)	1.8 (3.97)

[Unit: mm]

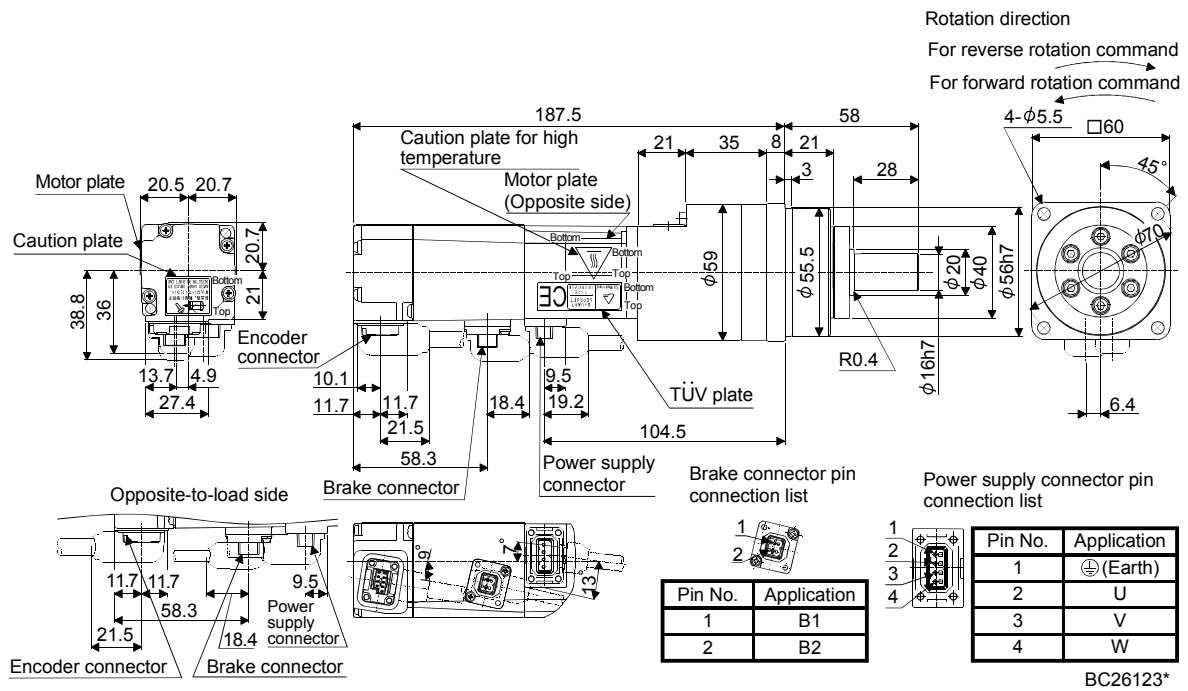

## 6. HF-MP SERIES · HF-KP SERIES

Model	Output [W]	Brake static friction torque [N · m] (oz · in)	Reduction gear model	Reduction ratio	Inertia moment J [ $\times 10^{-4} \text{kg} \cdot \text{m}^2$ ] ( $\text{WK}^2$ [oz · in <sup>2</sup> ])	Mass [kg] (lb)
HF-MP13BG7	100	0.32 (45.3)	HPG-20A-33-J2JMLAS-S	1/33	0.102 (0.558)	3.3 (7.28)
			HPG-20A-45-J2JMLAS-S	1/45	0.100 (0.547)	
HF-KP13BG7	100	0.32 (45.3)	HPG-20A-33-J2JMLAS-S	1/33	0.153 (0.837)	3.3 (7.28)
			HPG-20A-45-J2JMLAS-S	1/45	0.151 (0.826)	

[Unit: mm]

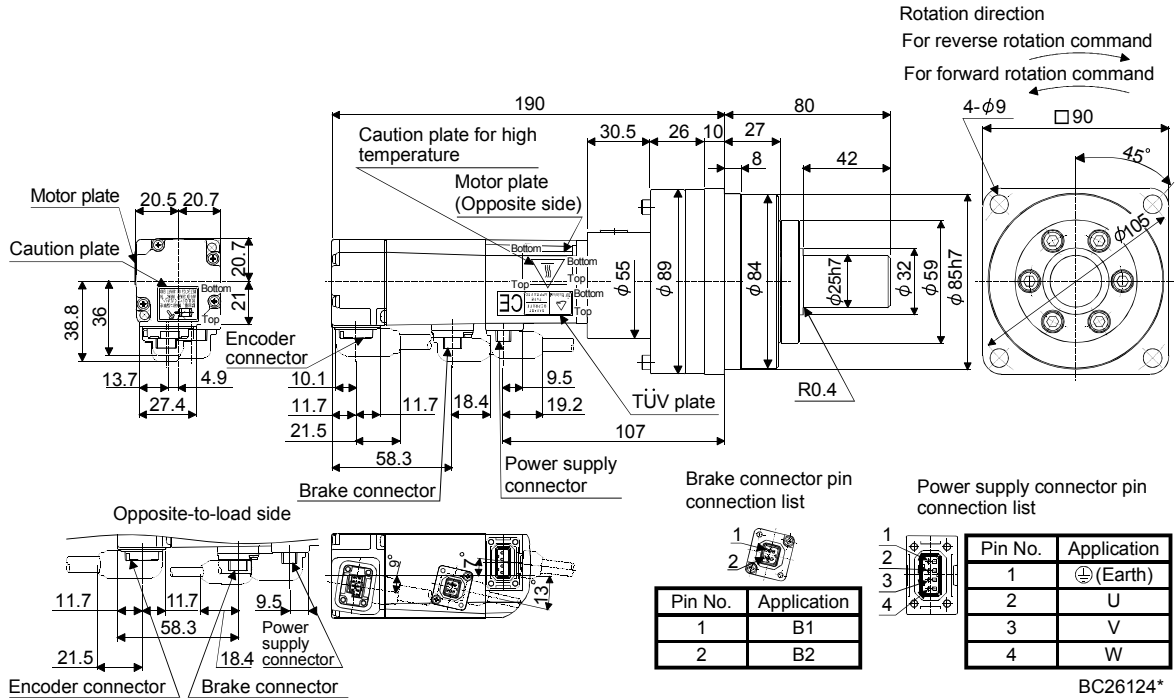

## 6. HF-MP SERIES · HF-KP SERIES

Model	Output [W]	Brake static friction torque [N · m] (oz · in)	Reduction gear model	Reduction ratio	Inertia moment $J [\times 10^{-4} \text{kg} \cdot \text{m}^2] (\text{WK}^2 [\text{oz} \cdot \text{in}^2])$	Mass [kg] (lb)
HF-MP23BG7	200	1.3 (184)	HPG-14A-05-J2AZW-S	1/5	0.327 (1.79)	2.5 (5.51)
			HPG-14A-11-J2AZX-S	1/11	0.323 (1.77)	2.6 (5.73)
HF-KP23BG7	200	1.3 (184)	HPG-14A-05-J2AZW-S	1/5	0.517 (2.83)	2.5 (5.51)
			HPG-14A-11-J2AZX-S	1/11	0.513 (2.81)	2.6 (5.73)

[Unit: mm]

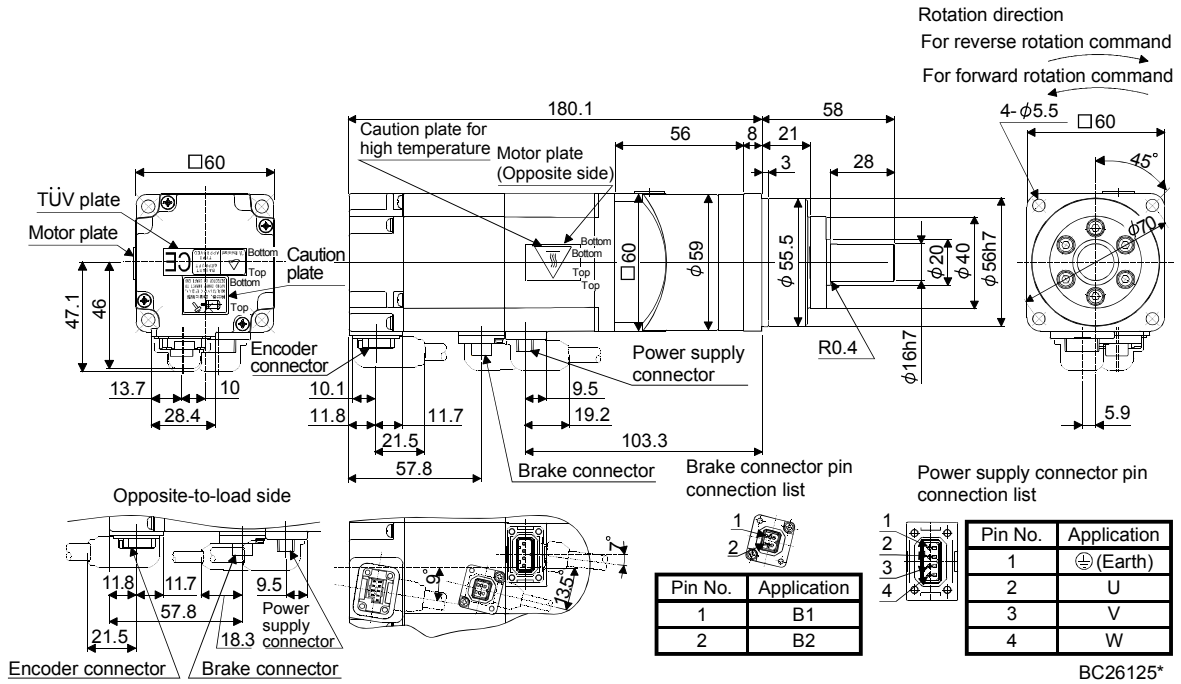

## 6. HF-MP SERIES · HF-KP SERIES

Model	Output [W]	Brake static friction torque [N · m] (oz · in)	Reduction gear model	Reduction ratio	Inertia moment J [ $\times 10^{-4}$ kg · m <sup>2</sup> ] (WK <sup>2</sup> [oz · in <sup>2</sup> ])	Mass [kg] (lb)
HF-MP23BG7	200	1.3 (184)	HPG-20A-21-J2EKS-S	1/21	0.620 (3.39)	4.5 (9.92)
			HPG-20A-33-J2ELS-S	1/33	0.573 (3.13)	
			HPG-20A-45-J2ELS-S	1/45	0.571 (3.12)	
HF-KP23BG7	200	1.3 (184)	HPG-20A-21-J2EKS-S	1/21	0.810 (4.43)	4.5 (9.92)
			HPG-20A-33-J2ELS-S	1/33	0.763 (4.17)	
			HPG-20A-45-J2ELS-S	1/45	0.761 (4.16)	

[Unit: mm]

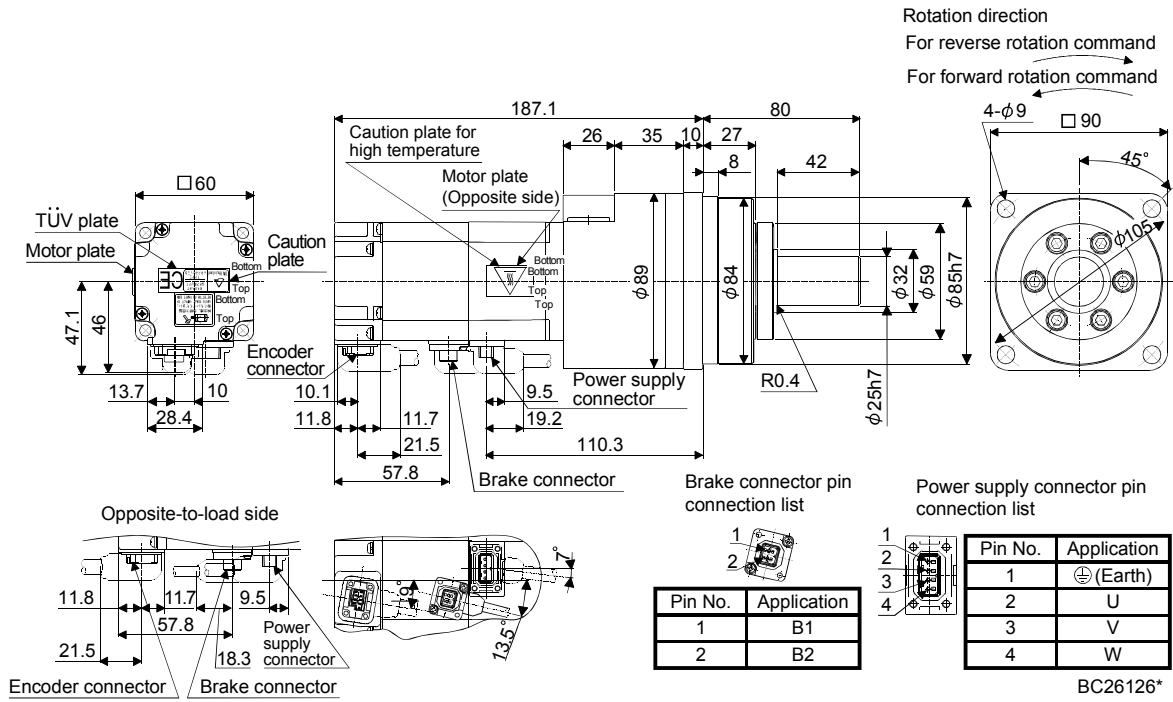

## 6. HF-MP SERIES · HF-KP SERIES

Model	Output [W]	Brake static friction torque [N · m] (oz · in)	Reduction gear model	Reduction ratio	Inertia moment $J [\times 10^{-4} \text{kg} \cdot \text{m}^2] (\text{WK}^2 [\text{oz} \cdot \text{in}^2])$	Mass [kg] (lb)
HF-MP43BG7	400	1.3 (184)	HPG-14A-05-J2AZW-S	1/5	0.387 (2.12)	3.0 (6.61)
HF-KP43BG7	400	1.3 (184)	HPG-14A-05-J2AZW-S	1/5	0.707 (3.87)	3.0 (6.61)

[Unit: mm]

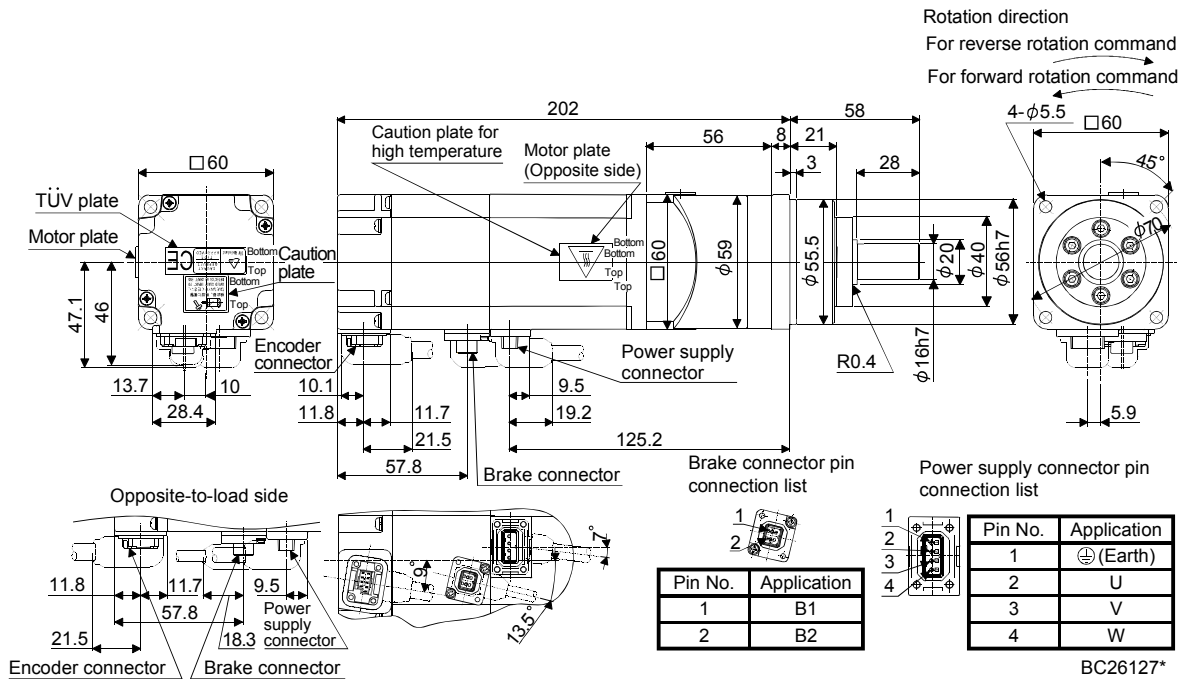

Model	Output [W]	Brake static friction torque [N · m] (oz · in)	Reduction gear model	Reduction ratio	Inertia moment $J [\times 10^{-4} \text{kg} \cdot \text{m}^2] (\text{WK}^2 [\text{oz} \cdot \text{in}^2])$	Mass [kg] (lb)
HF-MP43BG7	400	1.3 (184)	HPG-20A-11-J2EKS-S	1/11	0.76 (4.16)	5.0 (11.0)
			HPG-20A-21-J2EKS-S	1/21	0.68 (3.72)	
HF-KP43BG7	400	1.3 (184)	HPG-20A-11-J2EKS-S	1/11	1.08 (5.91)	5.0 (11.0)
			HPG-20A-21-J2EKS-S	1/21	1.00 (5.47)	

[Unit: mm]

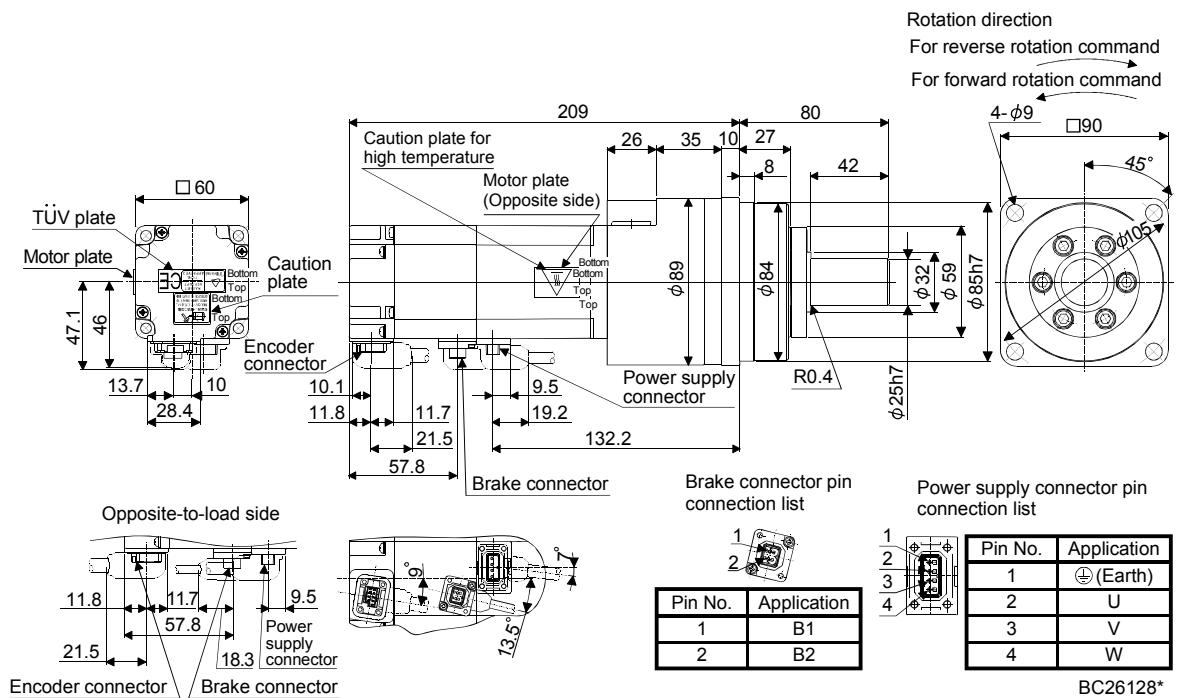

## 6. HF-MP SERIES · HF-KP SERIES

Model	Output [W]	Brake static friction torque [N · m] (oz · in)	Reduction gear model	Reduction ratio	Inertia moment J [ $\times 10^{-4}$ kg · m <sup>2</sup> ] (WK <sup>2</sup> [oz · in <sup>2</sup> ])	Mass [kg] (lb)
HF-MP43BG7	400	1.3 (184)	HPG-32A-33-J2RLAS-S	1/33	0.74 (4.05)	8.1 (17.9)
			HPG-32A-45-J2RLAS-S	1/45	0.73 (3.99)	
HF-KP43BG7	400	1.3 (184)	HPG-32A-33-J2RLAS-S	1/33	1.06 (5.80)	8.1 (17.9)
			HPG-32A-45-J2RLAS-S	1/45	1.05 (5.74)	

[Unit: mm]

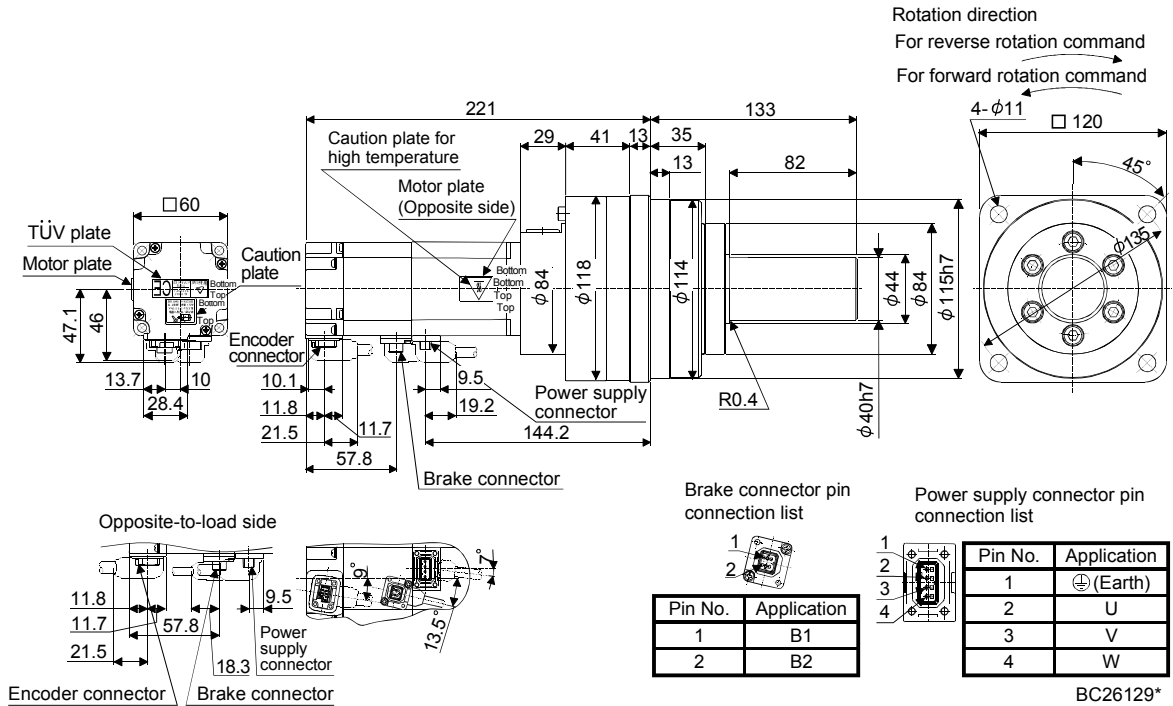

## 6. HF-MP SERIES · HF-KP SERIES

Model	Output [W]	Brake static friction torque [N · m] ([oz · in])	Reduction gear model	Reduction ratio	Inertia moment J [ $\times 10^{-4} \text{kg} \cdot \text{m}^2$ ] ( $\text{WK}^2$ [oz · in <sup>2</sup> ])	Mass [kg] ([lb])
HF-MP73BG7	750	2.4 (340)	HPG-20A-05-J2FEOS-S	1/5	1.39 (7.6)	6.3 (13.9)
			HPG-20A-11-J2FEPS-S	1/11	1.27 (6.94)	6.6 (14.6)
HF-KP73BG7	750	2.4 (340)	HPG-20A-05-J2FEOS-S	1/5	2.32 (12.7)	6.3 (13.9)
			HPG-20A-11-J2FEPS-S	1/11	2.20 (12.0)	6.6 (14.6)

[Unit: mm]

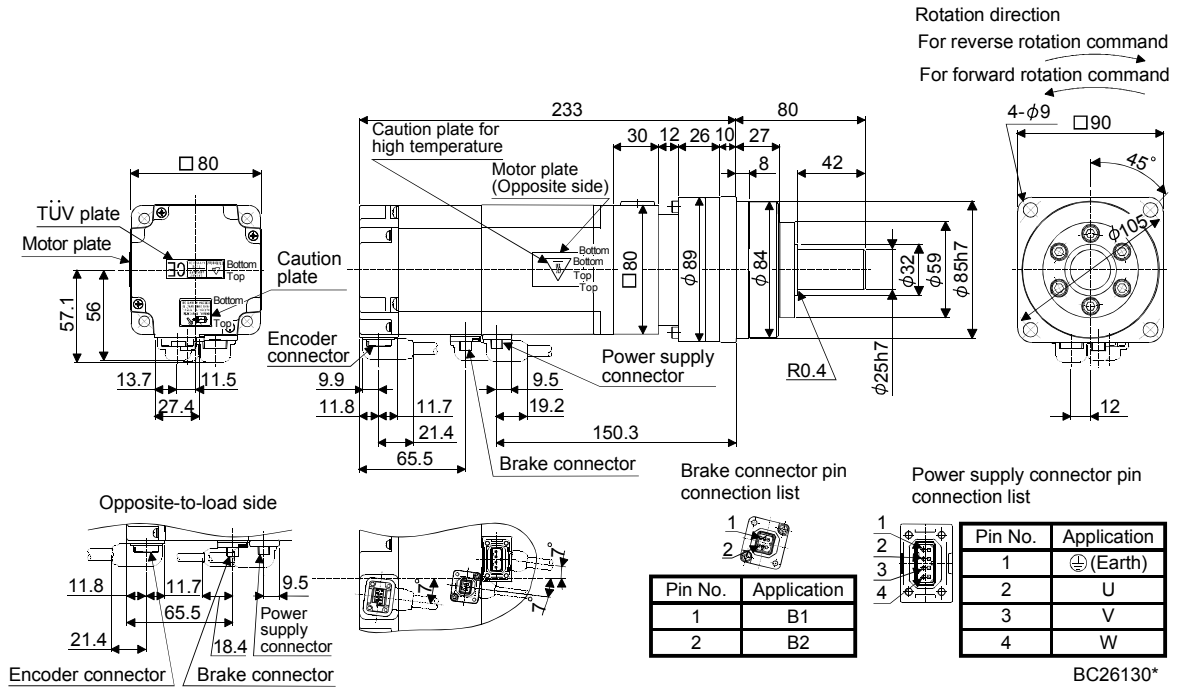

## 6. HF-MP SERIES · HF-KP SERIES

Model	Output [W]	Brake static friction torque [N · m] (oz · in)	Reduction gear model	Reduction ratio	Inertia moment J [ $\times 10^{-4}$ kg · m <sup>2</sup> ] (WK <sup>2</sup> [oz · in <sup>2</sup> ])	Mass [kg] (lb)
HF-MP73BG7	750	2.4 (340)	HPG-32A-21-J2SEIS-S	1/21	1.47 (8.04)	9.7 (21.4)
			HPG-32A-33-J2SEJS-S	1/33	1.24 (6.78)	
			HPG-32A-45-J2SEJS-S	1/45	1.23 (6.73)	
HF-KP73BG7	750	2.4 (340)	HPG-32A-21-J2SEIS-S	1/21	2.40 (13.1)	9.7 (21.4)
			HPG-32A-33-J2SEJS-S	1/33	2.17 (11.9)	
			HPG-32A-45-J2SEJS-S	1/45	2.16 (11.8)	

[Unit: mm]

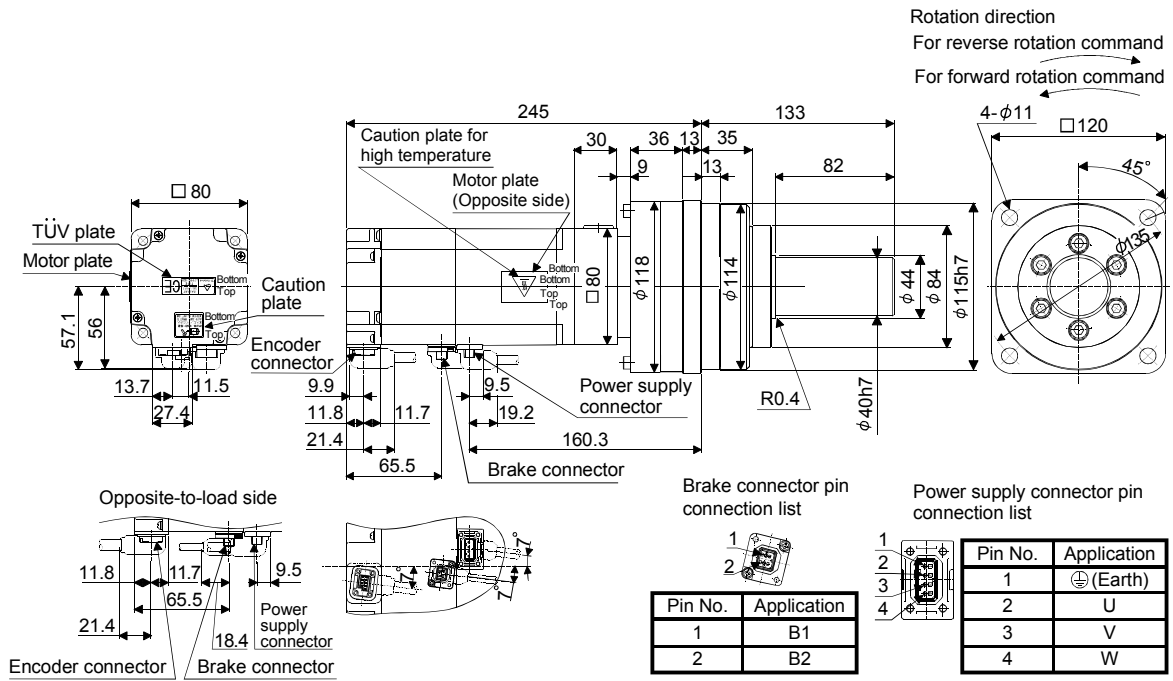

BC26131\*



# MEMO

---

---

---

---

---

---

---

---

---

---

---

---

---

---

---

---

---

---

---

---

---

---

---

---

# 7. HF-SP SERIES

## 7. HF-SP SERIES

This chapter provides information on the servo motor specifications and characteristics. When using the HF-SP series servo motor, always read the Safety Instructions in the beginning of this manual and chapters 1 to 4, in addition to this chapter.

### 7.1 Model name make up

The following describes what each block of a model name indicates. Note that not all the combinations of the symbols exist.

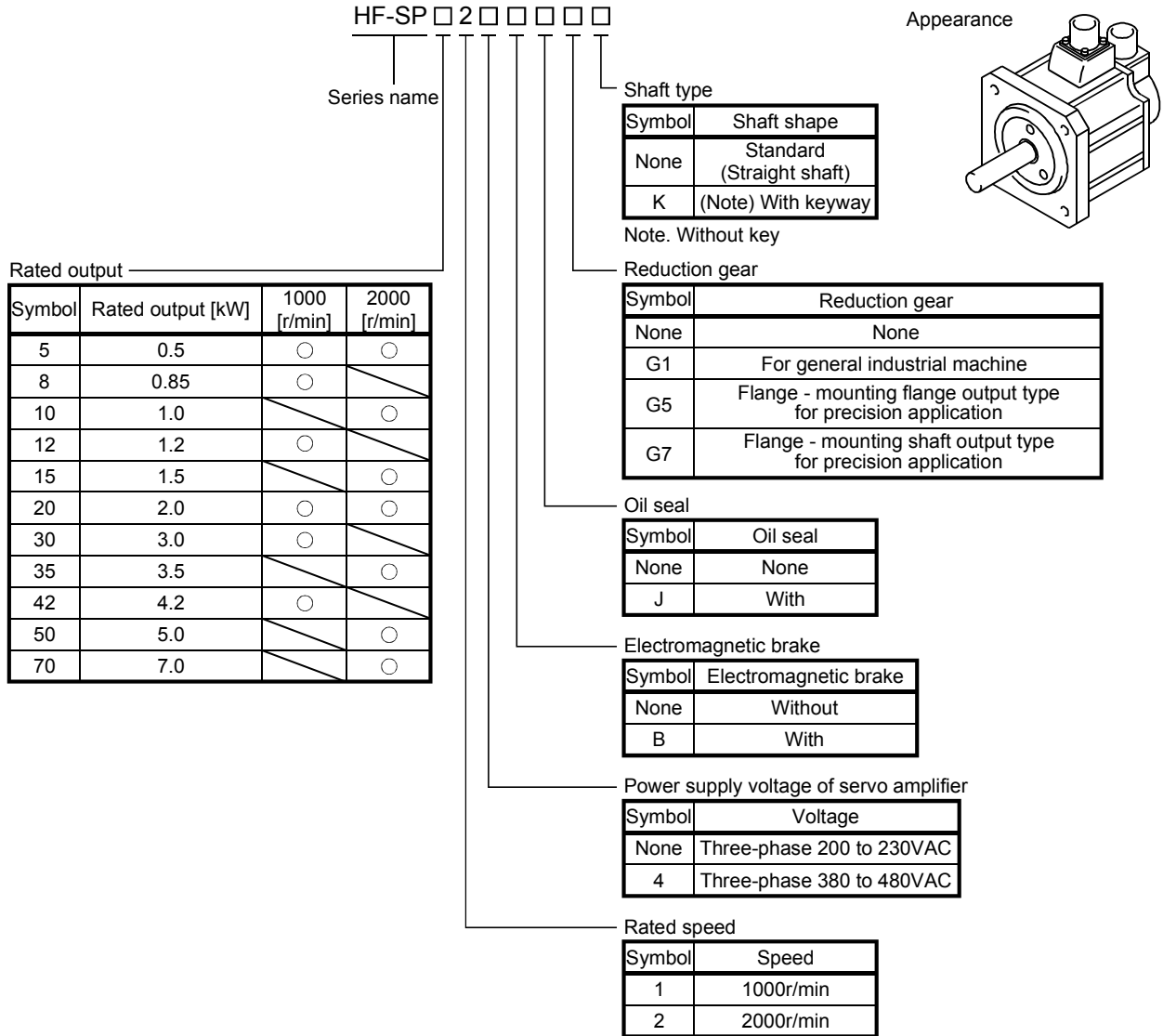

## 7. HF-SP SERIES

### 7.2 Standard specifications

#### 7.2.1 Standard specifications list

Servo motor			HF-SP 1000r/min series					
			(200VAC-compatible, medium inertia • medium capacity)					
Item			51	81	121	201	301	421
Applicable servo amplifier/drive unit	MR-J3-□A/B/B-RJ006/T		60	100	200		350	500
Continuous running duty	Rated output [kW]		0.5	0.85	1.2	2.0	3.0	4.2
	Rated torque	[N • m]	4.77	8.12	11.5	19.1	28.6	40.1
		[oz • in]	675	1150	1630	2700	4050	5680
Rated speed (Note 1)		[r/min]	1000					
Maximum speed		[r/min]	1500					
Instantaneous permissible speed		[r/min]	1725					
Maximum torque		[N • m]	14.3	24.4	34.4	57.3	85.9	120
		[oz • in]	2030	3460	4870	8110	12200	17000
Power rate at continuous rated torque		[kW/s]	19.2	37.0	34.3	48.6	84.6	104
Inertia moment (Note 3)	J	[ $\times 10^{-4}$ kg • m <sup>2</sup> ]	11.9	17.8	38.3	75.0	97.0	154
	WK <sup>2</sup>	[oz • in <sup>2</sup> ]	65.1	97.3	209	410	530	842
Recommended ratio of load inertia moment to servo motor shaft inertia moment (Note 2, 10)			15 times or less					
Power supply capacity			Refer to "Power supply equipment capacity and generated loss of servo amplifiers" in Servo Amplifier Instruction Manual.					
Rated current		[A]	2.9	4.5	6.5	11	16.0	24.0
Maximum current		[A]	8.7	13.5	19.5	33	48.0	72.0
Speed/position detector			Encoder common to absolute position and incremental detection systems (Resolution per servo motor 1 rotation: 262144pulse/rev)					
Accessory			— (Note 11)					
Insulation class			155(F)					
Structure			Totally – enclosed, natural-cooling (IP rating: IP67 (Note 4, 9))					
Environmental conditions (Note 5)	Ambient temperature	Operation	[°C]	0 to 40 (non-freezing)				
			[°F]	32 to 104 (non-freezing)				
		Storage	[°C]	–15 to 70 (non-freezing)				
			[°F]	5 to 158 (non-freezing)				
	Ambient humidity	Operation		80%RH or less (non-condensing)				
		Storage		90%RH or less (non-condensing)				
	Ambience		Indoors (no direct sunlight) Free from corrosive gas, flammable gas, oil mist, dust and dirt.					
	Altitude		Max.1000m above sea level					
	Vibration resistance (Note 6)		[m/s <sup>2</sup> ]	X, Y: 24.5		X: 24.5 Y: 49		X: 24.5 Y: 29.4
Vibration rank (Note 7)			V10					
Permissible load for the shaft (Note 8)	L		[mm]	55		79		
	Radial			[N]	980		2058	
				[lb]	220		463	
	Thrust			[N]	490		980	
				[lb]	110		220	
Mass (Note 3)		[kg]	6.5	8.3	12	19	22	32
		[lb]	14.3	18.3	26.5	41.9	48.5	70.6

## 7. HF-SP SERIES

Servo motor		HF-SP 2000r/min series (200VAC-compatible, medium inertia · medium capacity)							
		52	102	152	202	352	502	702	
Applicable servo amplifier/drive unit	MR-J3-□A/B/B-RJ006/T	60	100	200	200	350	500	700	
Continuous running duty	Rated output [kW]	0.5	1.0	1.5	2	3.5	5.0	7.0	
	Rated torque	[N · m]	2.39	4.77	7.16	9.55	16.7	23.9	33.4
		[oz · in]	338	675	1010	1350	2360	3380	4730
Rated speed (Note 1)	[r/min]	2000							
Maximum speed	[r/min]	3000							
Instantaneous permissible speed	[r/min]	3450							
Maximum torque	[N · m]	7.16	14.3	21.5	28.6	50.1	71.6	100	
	[oz · in]	1010	2030	3040	4050	7090	10100	14200	
Power rate at continuous rated torque	[kW/s]	9.34	19.2	28.8	23.8	37.2	58.8	72.5	
Inertia moment (Note 3)	J [ $\times 10^{-4}$ kg · m <sup>2</sup> ]	6.1	11.9	17.8	38.3	75.0	97.0	154	
	WK <sup>2</sup> [oz · in <sup>2</sup> ]	33.4	65.1	97.3	209	410	530	842	
Recommended ratio of load inertia moment to servo motor shaft inertia moment (Note 2, 10)		15 times or less							
Power supply capacity		Refer to "Power supply equipment capacity and generated loss of servo amplifiers" in Servo Amplifier Instruction Manual.							
Rated current	[A]	2.9	5.3	8.0	10	16	24	33	
Maximum current	[A]	8.7	15.9	2.4	30	48	72	99	
Speed/position detector		Encoder common to absolute position and incremental detection systems (Resolution per servo motor 1 rotation: 262144pulse/rev)							
Accessory		– (Note 11)							
Insulation class		155(F)							
Structure		Totally – enclosed, natural-cooling (IP rating: IP67 (Note 4, 9))							
Environmental conditions (Note 5)	Ambient temperature	Operation	[°C]	0 to 40 (non-freezing)					
			[°F]	32 to 104 (non-freezing)					
		Storage	[°C]	– 15 to 70 (non-freezing)					
			[°F]	5 to 158 (non-freezing)					
	Ambient humidity	Operation	80%RH or less (non-condensing)						
		Storage	90%RH or less (non-condensing)						
	Ambience	Indoors (no direct sunlight) Free from corrosive gas, flammable gas, oil mist, dust and dirt.							
	Altitude	Max.1000m above sea level							
Vibration resistance (Note 6)	[m/s <sup>2</sup> ]	X, Y: 24.5		X: 24.5 Y: 49		X: 24.5 Y: 29.4			
Vibration rank (Note 7)		V10							
Permissible load for the shaft (Note 8)	L	[mm]	55			79			
		Radial	[N]	980			2058		
	[lb]		220			463			
	Thrust	[N]	490			980			
		[lb]	110			220			
Mass (Note 3)	[kg]	4.8	6.5	8.3	12	19	22	32	
	[lb]	10.6	14.3	18.3	26.5	41.9	48.5	70.6	

## 7. HF-SP SERIES

Servo motor		HF-SP series (400VAC-compatible, medium inertia • medium capacity)							
		524	1024	1524	2024	3524	5024	7024	
Applicable servo amplifier/drive unit	MR-J3-□A4/B4/B4-RJ006/T4	60	100	200		350	500	700	
Continuous running duty	Rated output [kW]	0.5	1.0	1.5	2	3.5	5.0	7.0	
	Rated torque	[N • m]	2.39	4.77	7.16	9.55	16.7	23.9	33.4
		[oz • in]	338	675	1010	1350	2360	3380	4730
Rated speed (Note 1)		[r/min] 2000							
Maximum speed		[r/min] 3000							
Instantaneous permissible speed		[r/min] 3450							
Maximum torque		[N • m]	7.16	14.3	21.5	28.6	50.1	71.6	100
		[oz • in]	1010	2030	3040	4050	7090	10100	14200
Power rate at continuous rated torque		[kW/s]	9.34	19.2	28.8	23.8	37.2	58.8	72.5
Inertia moment (Note 3)	J [ $\times 10^{-4}$ kg • m <sup>2</sup> ]	6.1	11.9	17.8	38.3	75.0	97.0	154	
	WK <sup>2</sup> [oz • in <sup>2</sup> ]	33.4	65.1	97.3	209	410	530	842	
Recommended ratio of load inertia moment to servo motor shaft inertia moment (Note 2, 10)		15 times or less							
Power supply capacity		Refer to "Power supply equipment capacity and generated loss of servo amplifiers" in Servo Amplifier Instruction Manual.							
Rated current		[A]	1.5	2.9	4.1	5.0	8.4	12	16
Maximum current		[A]	4.5	8.7	12	15	25	36	48
Speed/position detector		Encoder common to absolute position and incremental detection systems (Resolution per servo motor 1 rotation: 262144pulse/rev)							
Accessory		– (Note 11)							
Insulation class		155(F)							
Structure		Totally – enclosed, natural-cooling (IP rating: IP67 (Note 4, 9))							
Environmental conditions (Note 5)	Ambient temperature	Operation	[°C]	0 to 40 (non-freezing)					
			[°F]	32 to 104 (non-freezing)					
		Storage	[°C]	– 15 to 70 (non-freezing)					
			[°F]	5 to 158 (non-freezing)					
	Ambient humidity	Operation	80%RH or less (non-condensing)						
		Storage	90%RH or less (non-condensing)						
	Ambience		Indoors (no direct sunlight) Free from corrosive gas, flammable gas, oil mist, dust and dirt.						
	Altitude		Max.1000m above sea level						
Vibration resistance (Note 6)		[m/s <sup>2</sup> ]	X, Y: 24.5		X: 24.5 Y: 49		X: 24.5 Y: 29.4		
Vibration rank (Note 7)		V10							
Permissible load for the shaft (Note 8)	L	[mm]	55			79			
		Radial	[N]	980			2058		
	[lb]		220			463			
	Thrust	[N]	490			980			
		[lb]	110			220			
Mass (Note 3)		[kg]	4.8	6.7	8.5	13	19	22	32
		[lb]	10.6	14.8	18.7	28.7	41.9	48.5	70.6

## 7. HF-SP SERIES

Note 1. When the power supply voltage drops, the output and the rated speed cannot be guaranteed.

2. If the load inertia moment ratio exceeds the indicated value, please consult your local sales office.
3. Refer to the outline dimension drawing for the servo motor with an electromagnetic brake.
4. Except for the shaft-through portion.
5. In the environment where the servo motor is exposed to oil mist, oil and/or water, the servo motor of the standard specifications may not be usable. Please contact your local sales office for more details.
6. The vibration direction is as shown in the figure. The value is the one at the part that indicates the maximum value (normally the opposite-to-load side bracket). When the servo motor stops, fretting is likely to occur at the bearing. Therefore, suppress the vibration to about half of the permissible value.

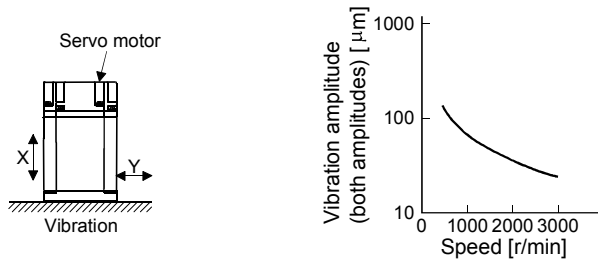

7. V10 indicates that the amplitude of a single servo motor is 10 $\mu\text{m}$  or less. The following figure shows the servo motor installation position for measurement and the measuring position.

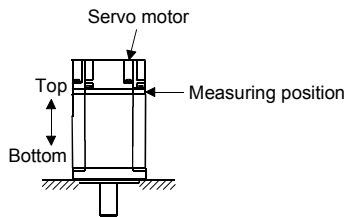

8. For the symbols in the table, refer to the following diagram: Do not subject the shaft to load greater than this value.  
The values in the table assume that the loads work singly.

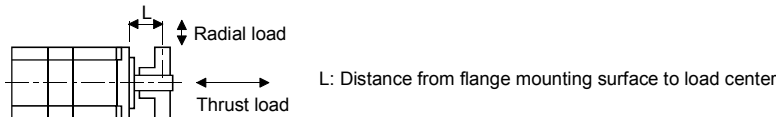

9. When the servo motor is provided with the reduction gear, the IP rating of the reduction gear section is IP44.
10. When the servo motor is provided with the reduction gear, refer to section 7.6.
11. The servo motors with an oil seal (HF-SP□J) are available as optional products.

## 7. HF-SP SERIES

### 7.2.2 Torque characteristics

<b>POINT</b>
<ul style="list-style-type: none"> <li>For machines which produce unbalance torque, e.g. vertical lift applications, it is recommended to use the servo motor so that the unbalance torque will be within 70% of the rated torque.</li> </ul>

#### (1) 3-phase 200VAC

When the power input of the servo amplifier are 3-phase 200VAC or 1-phase 230VAC, the torque characteristic is indicated by the heavy line. For the 1-phase 200VAC power supply, part of the torque characteristic is indicated by the thin line. HF-SP51 and HF-SP52 support 1-phase power supply input.

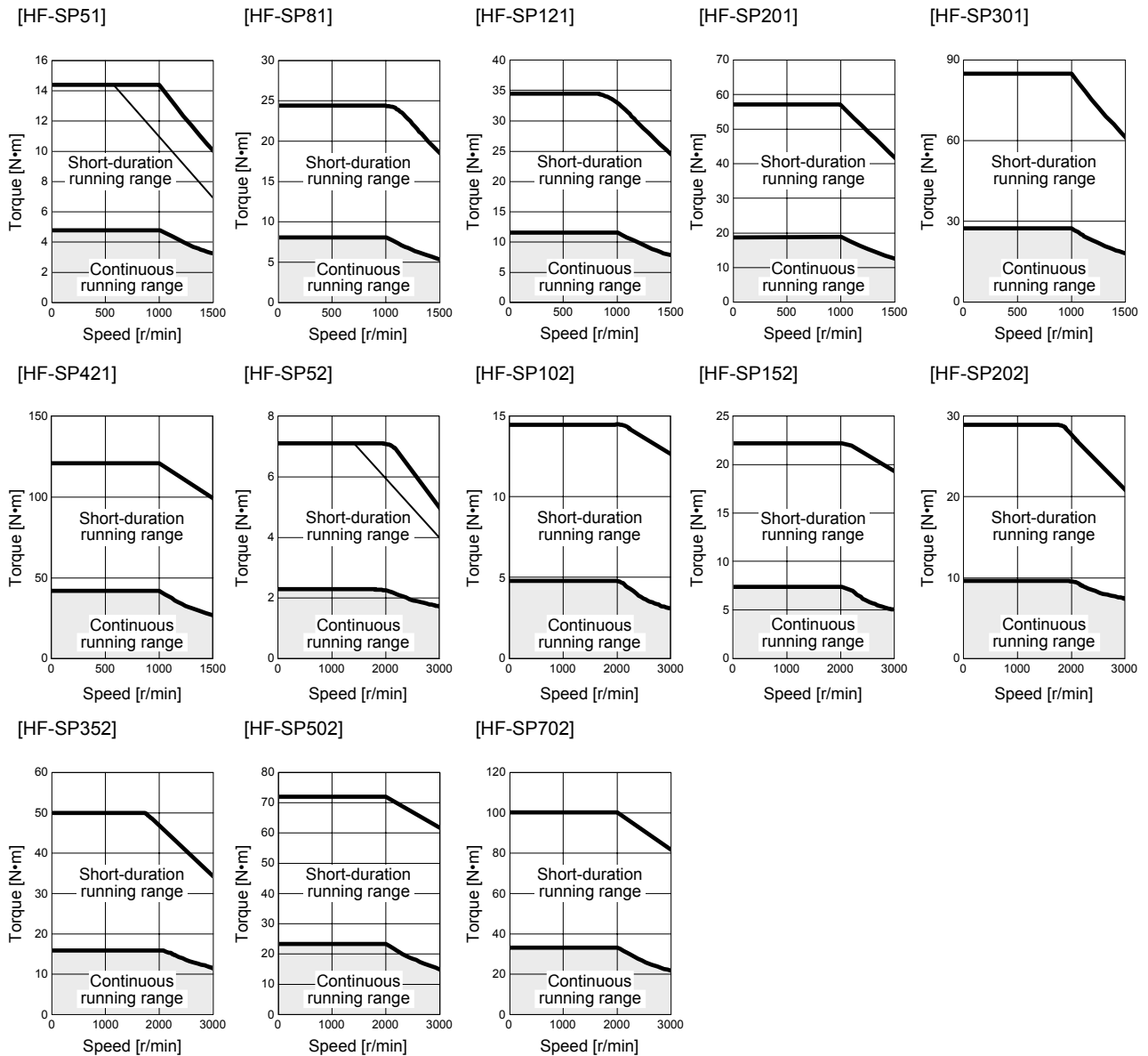

## 7. HF-SP SERIES

### (2) 3-phase 400VAC

When the power input of the servo amplifier are 3-phase 400VAC, the torque characteristic is indicated by the heavy line. For the 3-phase 380VAC power supply, part of the torque characteristic is indicated by the thin line.

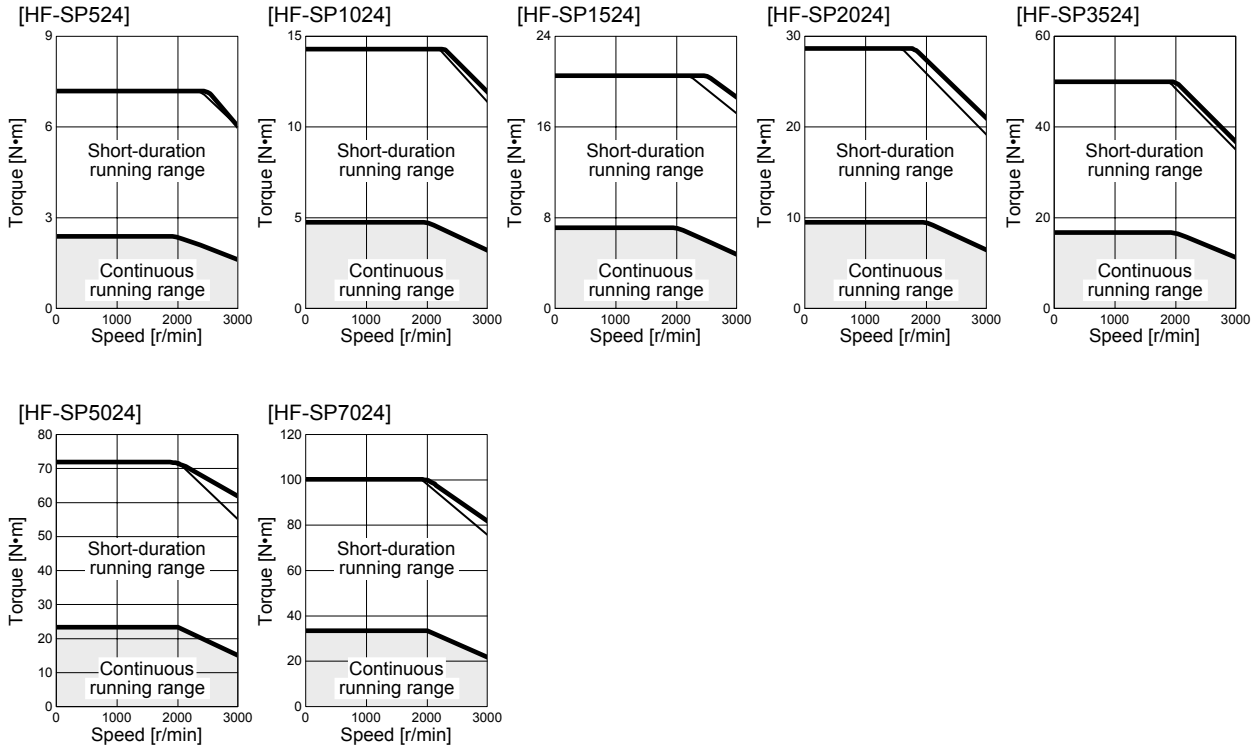



## 7. HF-SP SERIES

### 7.3 Electromagnetic brake



#### CAUTION

- The electromagnetic brake is provided to prevent a drop at a power failure or servo alarm occurrence during vertical drive or to hold a shaft at a stop. Do not use it for normal braking (including braking at servo lock).
- Before performing the operation, be sure to confirm that the electromagnetic brake operates properly.
- The operation time of the electromagnetic brake differs depending on the power supply circuit you use. Be sure to check the operation delay time with a real machine.

The characteristics of the electromagnetic brake provided for the servo motor with an electromagnetic brake are indicated below.

Item	Servo motor	HF-SP series	
		51B・81B 52(4)B to 152(4)B	121B to 421B 202(4)B to 702(4)B
Type (Note 1)		Spring-loaded safety brake	
Rated voltage (Note 4)		24V <sup>0</sup> <sub>-10%</sub> DC	
Capacity	[W] at 20°C (68°F)	20	34
Coil resistance (Note 6)	[Ω]	29.0	16.8
Inductance (Note 6)	[H]	0.80	1.10
Brake static friction torque	[N・m]	8.5	44
	[oz・in]	1200	6230
Release delay time (Note 2)	[s]	0.04	0.1
Braking delay time (Note 2)	[s]	0.03	0.03
	DC off		
Permissible braking work	Per braking [J]	400	4500
	Per hour [J]	4000	45000
Brake looseness at servo motor shaft (Note 5)	[degrees]	0.2 to 0.6	0.2 to 0.6
Brake life (Note 3)	Number of braking cycles [times]	20000	20000
	Work per braking [J]	200	1000
Selection example of surge absorbers to be used (Note 7, 8)	For the suppressed voltage 125V	TND20V-680KB	
	For the suppressed voltage 350V	TND10V-221KB	

Note 1. There is no manual release mechanism. When it is necessary to hand-turn the servo motor shaft for machine centering, etc., use a separate 24VDC power supply to release the brake electrically.

2. The value for initial ON gap at 20°C (68°F).

3. The brake gap will increase as the brake lining wears, but the gap is not adjustable. The brake life indicated is the number of braking cycles after which adjustment will be required.

4. Always prepare a power supply exclusively used for the electromagnetic brake.

5. The above values are typical initial values and not guaranteed values.

6. These values are measured values and not guaranteed values.

7. Select the electromagnetic brake control relay properly, considering the characteristics of the electromagnetic brake and surge absorber.

8. Manufactured by Nippon Chemi-Con Corporation.

## 7. HF-SP SERIES

### 7.4 Servo motors with special shafts

The servo motors with special shafts indicated by the symbol (K) in the table is available. K is the symbols attached to the servo motor model names.

Servo motor	Shaft shape
	Keyway shaft (without key)
HF-SP51(B)□ to 301(B)□ HF-SP52(4)(B)□ to 702(4)(B)□	K

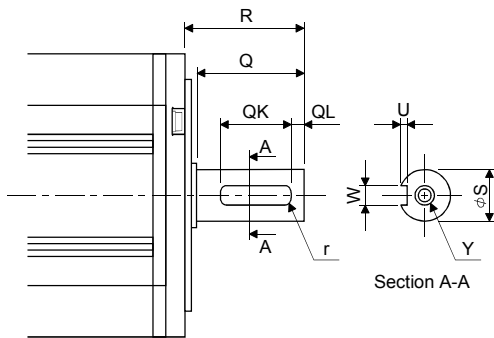

Variable dimension table

[Unit: mm]

Servo motor	Variable dimensions								Y
	S	R	Q	W	QK	QL	U	r	
HF-SP51(B)K · 81(B)K HF-SP52(4)(B)K to 152(4)(B)K	24h6	55	50	$8_{-0.036}^0$	36	5	$4_{+0.2}^0$	4	M8 Depth 20
HF-SP121(B)K to 421(B)K HF-SP202(4)(B)K to 702(4)(B)K	$35_{+0.010}^0$	79	75	$10_{-0.036}^0$	55	5	$5_{+0.2}^0$	5	M8 Depth 20

Keyway shaft (without key)

### 7.5 Servo motor with oil seal

HP-SP series has the servo motor with oil seal(HF-SP□J) Model construction of the servo motor refer to section 7.1. Mounting the oil seal is regardless to outline dimensions. Install the servo motor horizontally, and set the oil level in the gear box to be lower than the oil seal lip always.

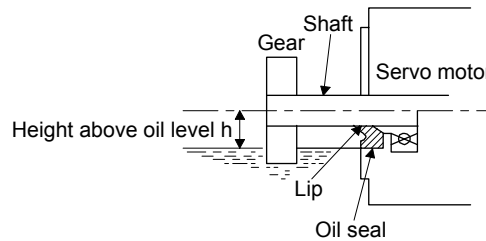

Servo motor	Height above oil level h [mm]
HF-SP81(B)J	20
HF-SP121(B)J to 301(B)J	25
HF-SP52(4)(B)J to 152(4)(B)J	20
HF-SP202(4)(B)J to 702(4)(B)J	25

## 7. HF-SP SERIES

### 7.6 Servo motors with a reduction gear



**CAUTION**

- The servo motor with a reduction gear must be installed in the specified direction. Otherwise, it can leak oil, leading to a fire or fault.
- For the servo motor with a reduction gear, transport it in the same status as in the installation method. Tipping it over can cause oil leakage.

Servo motors are available with a reduction gear designed for general industrial machines compliant and precision applications compliant.

Servo motors with an electromagnetic brake are also available.

#### 7.6.1 For general industrial machines compliant (G1/G1H)

##### (1) Manufacturing range

The following table indicates the reduction ratios and reduction gear frame numbers of the servo motors with a reduction gear for general industrial machines compliant. The servo motors with a reduction gear of the following reduction ratios are available.

Servo motor	Reduction ratio						
	1/6	1/11	1/17	1/29	1/35	1/43	1/59
HF-SP52(4)(B)G1(H)	6100			6120			
HF-SP102(4)(B)G1(H)	6120					6130	6160
HF-SP152(4)(B)G1(H)	6120			6130		6160	
HF-SP202(4)(B)G1(H)	6120			6165			
HF-SP352(4)(B)G1(H)	6135			6165		6175	
HF-SP502(4)(B)G1(H)	6165			6180			6185
HF-SP702(4)(B)G1(H)	6165	6170		6180		6195	

##### (2) Specifications

Item	Description
Mounting method	Refer to (2)(b) in this section
Mounting direction	Refer to (2)(b) in this section
Lubrication method	Refer to (2)(b) * (c) in this section
(Note 1) Recommended products	Refer to (2)(c) in this section
Output shaft rotating direction	Opposite direction to the servo motor shaft
With an electromagnetic brake	Available
Backlash	40 minutes to 2* at reduction gear output shaft
(Note 2) Permissible load inertia moment ratio (when converting into the servo motor shaft)	4 times or less
Permissible speed (at servo motor shaft)	Refer to (2)(a) in this section
Reduction gear efficiency (Note 3)	85 to 94%

Note 1. Already packed with grease.

2. If the above indicated value is exceeded, please consult your local sales office.

3. The reduction gear efficiency differs depending on the reduction ratio.

Also, it changes depending on the use conditions such as the output torque, speed and rotation, temperature, etc. The numerical value in the table is a typical value in the rated torque, rated speed and rotation and typical temperature, and not a guaranteed value.

## 7. HF-SP SERIES

### (a) Permissible speed

Servo motor	Deceleration constant						
	1/6	1/11	1/17	1/29	1/35	1/43	1/59
HF-SP52(4)(B)G1(H)							
HF-SP102(4)(B)G1(H)		3000r/min					
HF-SP152(4)(B)G1(H)							
HF-SP202(4)(B)G1(H)							
HF-SP352(4)(B)G1(H)					2000r/min		
HF-SP502(4)(B)G1(H)							
HF-SP702(4)(B)G1(H)							

### (b) Lubrication of reduction gears for general industrial machines

Oil lubrication cannot be used in applications where the servo motor will move. Specify grease lubrication.

For grease lubrication, the reduction gear is already grease-packed.

For oil lubrication, pack the reduction gear with oil on the customer side.

Mounting direction Reduction gear model Reduction gear frame No.	Shaft any direction		Shaft horizontal		Shaft downward		Shaft upward	
	CNHM (leg type)	CNVM (flange type)	CHHM (leg type)	CHVM (flange type)	CVHM (leg type)	CVVM (flange type)	CWHM (leg type)	CWVM (flange type)
6100	Grease	Grease						
6120	Grease	Grease						
6130 · 6135			(Note) Oil	(Note) Oil	(Note) Oil	(Note) Oil	Grease	Grease
6160 · 6165			(Note) Oil	(Note) Oil	(Note) Oil	(Note) Oil	Grease	Grease
6170 · 6175			Oil	Oil	Oil	Oil		
6180 · 6185			Oil	Oil	Oil	Oil		
6195			Oil	Oil	Oil	Oil		

Note. Grease-lubricated type is also available.

## 7. HF-SP SERIES

### (c) Recommended Lubricants

#### 1) Grease

Albania Grease/Shell OIL

#### 2) Lubricating oil

<b>POINT</b>
<ul style="list-style-type: none"> <li>Since the oil-lubricated models are shipped without oil, make sure to fill oil up to the upper red line of the oil gauge before operation.</li> </ul>

Ambient temperature	COSMO OIL	JX Nippon Oil & Energy	IDEMITSU KOSAN CO., LTD	Shell OIL	ESSO OIL	Exxon Mobil	Japan Energy
-10 to 5°C (14 to 41°F)	COSMO GEAR SE68	BONNOC M68 DIAMOND GEAR LUBE SP68	DAPHNE SUPER GEAR OIL 68	Omala Oils 68	SPARTAN EP68	Mobilgear 626 (ISO VG68)	JOMO Reductus 68
0 to 35°C (32 to 95°F)	COSMO GEAR SE100 · 150	BONNOC M100 · 150 DIAMOND GEAR LUBE SP100 · 150	DAPHNE SUPER GEAR OIL 100 · 150	Omala Oils 100 · 150	SPARTAN EP100 · 150	Mobilgear 627 · 629 (ISO VG100 · 150)	JOMO Reductus 100 · 150
30 to 50°C (86 to 122°F)	COSMO GEAR SE200 · 320 · 460	BONNOC M200 to 460 DIAMOND GEAR LUBE SP220 to 460	/	Omala Oils 200 to 460	SPARTAN EP220 to 460	Mobilgear 630 to 634 (ISO VG220 to 460)	JOMO Reductus 200 to 460

### Lubricating oil fill amount

Reduction gear frame No.	Fill amount [ℓ]	
	Horizontal type	Vertical type
6130 · 6135	0.7	1.1
6160 · 6165	1.4	1.0
6170 · 6175	1.9	1.9
6180 · 6185	2.5	2.0
6195	4.0	2.7

### (d) Changing intervals of Lubricant for general industrial machines

#### 1) Grease

Maintenance-free. (Limited to the case where the grease-lubricated type is standard.)

#### 2) Lubricant

Changing intervals	Operation hours per day	
	Less than 10 hours	10 to 24 hours
First time	500 hours	
Second time and later	Half year	2500 hours

## 7. HF-SP SERIES

### (3) Permissible loads of servo motor shaft

The permissible radial load in the table is the value measured at the center of the reduction gear output shaft.

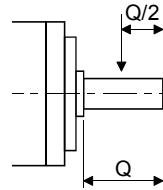

Q: Length of axis (Refer to section 7.8.3 to 7.8.6)

Servo motor	Reduction ratio	Permissible load (Note)			
		Permissible radial load		Permissible thrust load	
		[N]	[lb]	[N]	[lb]
HF-SP52(4) (B)G1(H)	1/6	2058	463	1470	330
	1/11	2391	538	1470	330
	1/17	2832	637	1470	330
	1/29	3273	736	1470	330
	1/35	5253	1181	2940	661
	1/43	5253	1181	2940	661
	1/59	5880	1322	2940	661
HF-SP102(4) (B)G1(H)	1/6	2842	639	2352	529
	1/11	3273	736	2764	621
	1/17	3646	820	2940	661
	1/29	4410	991	2940	661
	1/35	5253	1181	2940	661
	1/43	6047	1359	3920	881
	1/59	9741	2190	6860	1542
HF-SP152(4) (B)G1(H)	1/6	2842	639	2352	529
	1/11	3273	736	2764	621
	1/17	3646	820	2940	661
	1/29	5135	1154	3920	881
	1/35	6047	1359	3920	881
	1/43	8555	1923	6860	1542
	1/59	9741	2190	6860	1542
HF-SP202(4) (B)G1(H)	1/6	2842	639	2352	529
	1/11	3273	736	2764	621
	1/17	3646	820	2940	661
	1/29	7291	1639	6860	1542
	1/35	8555	1923	6860	1542
	1/43	8555	1923	6860	1542
	1/59	9741	2190	6860	1542

Servo motor	Reduction ratio	Permissible load (Note)			
		Permissible radial road		Permissible thrust load	
		[N]	[lb]	[N]	[lb]
HF-SP352(4) (B)G1(H)	1/6	3332	749	3920	881
	1/11	3871	870	3920	881
	1/17	4420	994	3920	881
	1/29	7291	1639	6860	1542
	1/35	8555	1923	6860	1542
	1/43	11662	2622	9800	2203
	1/59	13132	2952	9800	2203
HF-SP502(4) (B)G1(H)	1/6	5448	1225	5000	1124
	1/11	5488	1234	6292	1415
	1/17	6468	1454	6860	1542
	1/29	13426	3018	13720	3084
	1/35	16072	3613	13720	3084
	1/43	16072	3613	13720	3084
	1/59	16072	3613	13720	3084
HF-SP702(4) (B)G1(H)	1/6	7526	1692	5000	1124
	1/11	7526	1692	8085	1818
	1/17	8683	1952	9673	2175
	1/29	13426	3018	13720	3084
	1/35	16072	3613	13720	3084
	1/43	22540	5067	19600	4406
	1/59	22540	5067	19600	4406

Note. The load above this value should not be applied to the shaft.

The value in the table assumes that the load is applied independently.

## 7. HF-SP SERIES

### 7.6.2 For precision application compliant (G5/G7)

#### (1) Manufacturing range

The symbols (20A, 30A, 50A) in the following table indicate the model numbers of the reduction gears assembled to the servo motors.

Servo motors with a reduction gear having the indicated reduction gear model numbers are available.

The reduction gear model number indicates □□□ of the reduction number model name HPG-□□□-05.

Servo motor	Reduction ratio				
	1/5	1/11	1/21	1/33	1/45
HF-SP52(4)(B)G5 HF-SP52(4)(B)G7					
HF-SP102(4)(B)G5 HF-SP102(4)(B)G7	20A		32A		
HF-SP152(4)(B)G5 HF-SP152(4)(B)G7					
HF-SP202(4)(B)G5 HF-SP202(4)(B)G7			50A		
HF-SP352(4)(B)G5 HF-SP352(4)(B)G7					
HF-SP502(4)(B)G5 HF-SP502(4)(B)G7					
HF-SP702(4)(B)G5 HF-SP702(4)(B)G7					

#### (2) Specifications

Item	Description
Mounting method	Flange mounting
Mounting direction	In any directions
Lubrication method	Grease lubrication (Already packed) (Note 1)
Packed with	Reduction gear model number 20A, 32A: Harmonic grease SK-2 (Harmonic Drive Systems) Reduction gear model number 50A: Epiknock grease AP(N)2 (JX Nippon Oil & Energy)
Output shaft rotating direction	Same as the servo motor output shaft direction
With an electromagnetic brake	Available
Backlash	3 minutes or less at reduction gear output shaft
Permissible load inertia moment ratio (when converting into the servo motor shaft) (Note 2)	10 times or less
Permissible speed (at servo motor shaft)	3000 r/min
IP rating (reduction gear area)	IP44 equivalent
Reduction gear efficiency (Note 3)	77 to 92%

Note 1. Already packed with grease.

2. If the above indicated value is exceeded, please consult your local sales office.

3. The reduction gear efficiency differs depending on the reduction ratio.

Also, it changes depending on the use conditions such as the output torque, speed and rotation, temperature, etc.

The numerical value in the table is a typical value in the rated torque, rated speed and rotation and typical temperature, and not a guaranteed value.

## 7. HF-SP SERIES

### (3) Permissible loads of servo motor shaft

The radial load point of a precision reduction gear is as shown below.

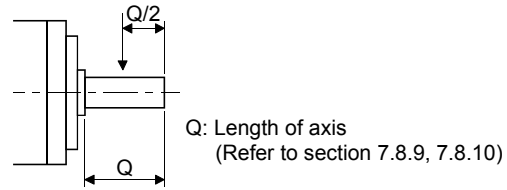
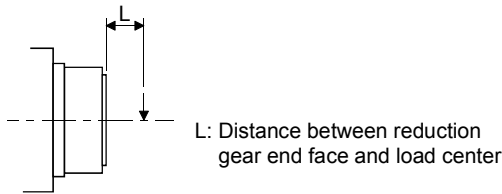

Flange-mounting flange output type for precision application compliant (G5)

Flange-mounting shaft output type for precision application compliant (G7)

Servo motor	Reduction ratio	Radial load point L [mm]	Permissible load (Note)			
			Permissible radial load		Permissible thrust load	
			[N]	[lb]	[N]	[lb]
HF-SP52(4)(B)G5 HF-SP52(4)(B)G7	1/5	32	416	93.5	1465	329
	1/11	32	527	118	1856	417
	1/21	57	1094	246	4359	980
	1/33	57	1252	281	4992	1120
	1/45	57	1374	309	5478	1230
HF-SP102(4)(B)G5 HF-SP102(4)(B)G7	1/5	32	416	93.5	1465	329
	1/11	57	901	203	3590	807
	1/21	57	1094	246	4359	980
	1/33	62	2929	658	10130	2280
	1/45	62	3215	723	11117	2500
HF-SP152(4)(B)G5 HF-SP152(4)(B)G7	1/5	32	416	93.5	1465	329
	1/11	57	901	203	3590	807
	1/21	62	2558	575	8845	1990
	1/33	62	2929	658	10130	2280
	1/45	62	3215	723	11117	2500
HF-SP202(4)(B)G5 HF-SP202(4)(B)G7	1/5	57	711	160	2834	637
	1/11	57	901	203	3590	807
	1/21	62	2558	575	8845	1990
	1/33	62	2929	658	10130	2280
	1/45	62	3215	723	11117	2500
HF-SP352(4)(B)G5 HF-SP352(4)(B)G7	1/5	57	711	160	2834	637
	1/11	62	2107	474	7285	1640
	1/21	62	2558	575	8845	1990
HF-SP502(4)(B)G5 HF-SP502(4)(B)G7	1/5	62	1663	374	5751	1290
	1/11	62	2107	474	7285	1640
HF-SP702(4)(B)G5 HF-SP702(4)(B)G7	1/5	62	1663	374	5751	1290

Note. The load above this value should not be applied to the shaft.

The value in the table assumes that the load is applied independently.



## 7. HF-SP SERIES

### (4) Special shaft servo motors

Servo motors with special shafts having keyway (with single pointed keys) are available for the flange-mounting shaft output type for precision applications compliant (G7).

[Unit: mm]

Servo motor	Reduction gear model number	Q	$\phi S$	W	T	QK	U	Y
HF-SP□(B)G7K	20A	42	25h7	8	7	36	4	M6 Depth 12
	32A	82	40h7	12	8	70	5	M10 Depth 20
	50A	82	50h7	14	9	70	5.5	Depth 20

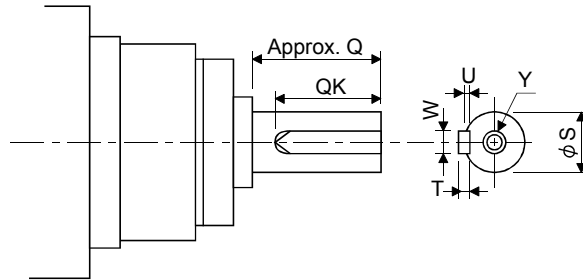

### 7.7 Wiring option

Connector sets to use in power supply connector or brake connector are available as option.

For details of each connector set, cable and connector set to use in wiring to encoder, refer to the Servo Amplifier Instruction Manual for using.

Make sure to use the following power supply connector set for conforming to the EN compliant.

Servo motor		(Note) Power supply connector set	Brake connector set
HF-SP	HF-SP51 * 81	MR-PWCNS4	MR-BKCNS1 Configuration products Straight plug : CM10-SP2S-L(D6) Socket contact : CM10-#22SC(S2)(D8)-100 (DDK)
	HF-SP52 to 152		
	HF-SP524 to 1524		
	HF-SP121 to 301	MR-PWCNS5	
	HF-SP202 to 502		
	HF-SP2024 to 5024	MR-PWCNS3	
	HF-SP421		
	HF-SP702		
HF-SP7024			

Note. The configuration products for power supply connector set are as shown below. (all manufactured by DDK)

MR-PWCNS4 (Plug: CE05-6A18-10SD-D-BSS Cable clamp: CE3057-10A-1-D

MR-PWCNS5 (Plug: CE05-6A22-22SD-D-BSS Cable clamp: CE3057-12A-1-D

MR-PWCNS3 (Plug: CE05-6A32-17SD-D-BSS Cable clamp: CE3057-20A-1-D

## 7. HF-SP SERIES

### 7.8 Outline dimension drawings

The dimensions without tolerances are reference dimensions.

The outer frame of the reduction gear is a material surface such as casting. Its actual dimensions may be 1 to 3mm larger than the drawing dimensions. Design the machine side with allowances.

Inertia moment on the table is the value calculated by converting the total value of inertia moment for servo motor, electromagnetic brake and decelerator with servo motor shaft.

#### 7.8.1 Standard (without an electromagnetic brake, without a reduction gear)

Model	Output [kW]	Inertia moment J [ $\times 10^{-4}$ kg · m <sup>2</sup> ] (WK <sup>2</sup> [oz · in <sup>2</sup> ])	Mass [kg] (lb)
HF-SP52	0.5	6.1 (33.4)	4.8 (10.6)
HF-SP524			

[Unit: mm]

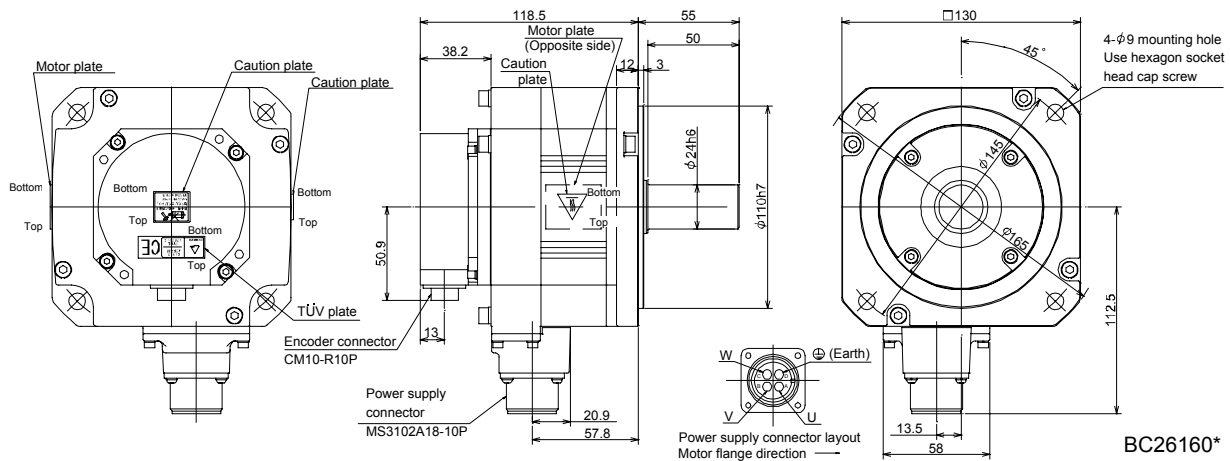

Model	Output [kW]	Inertia moment J [ $\times 10^{-4}$ kg · m <sup>2</sup> ] (WK <sup>2</sup> [oz · in <sup>2</sup> ])	Mass [kg] (lb)
HF-SP51	0.5	11.9 (65.1)	6.5 (14.3)
HF-SP102	1.0		
HF-SP1024			6.7 (14.8)

[Unit: mm]

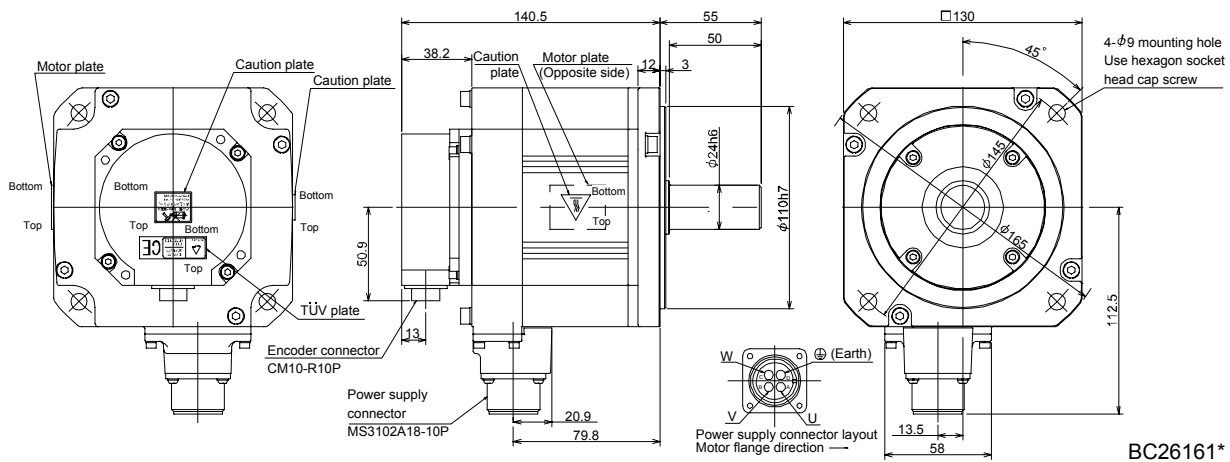

# 7. HF-SP SERIES

Model	Output [kW]	Inertia moment J [ $\times 10^{-4}$ kg · m <sup>2</sup> ] (WK <sup>2</sup> [oz · in <sup>2</sup> ])	Mass [kg] (lb)
HF-SP81	0.85	17.8 (97.3)	8.3 (18.3)
HF-SP152	1.5		8.5 (18.7)
HF-SP1524			

[Unit: mm]

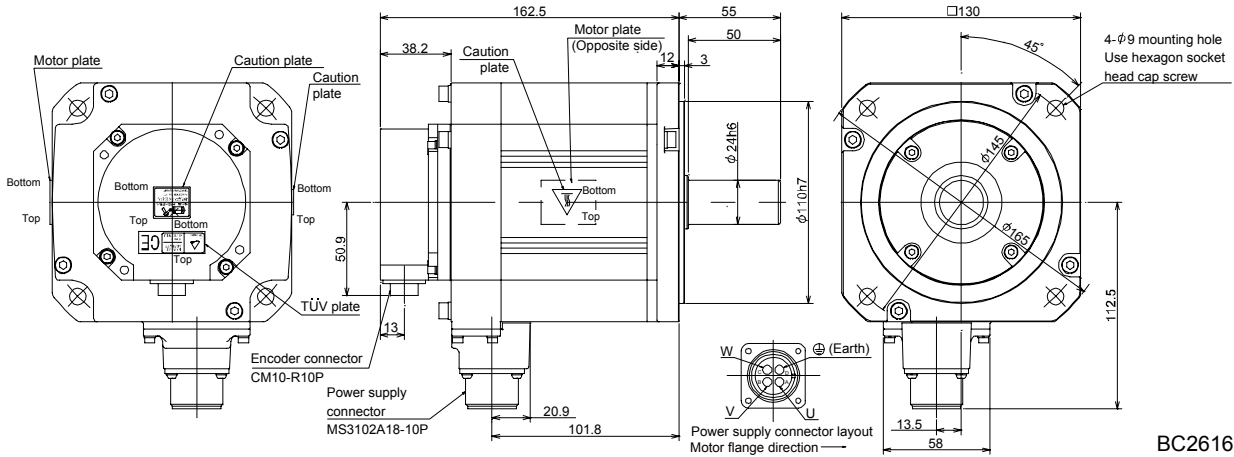

BC26162\*

Model	Output [kW]	Inertia moment J [ $\times 10^{-4}$ kg · m <sup>2</sup> ] (WK <sup>2</sup> [oz · in <sup>2</sup> ])	Mass [kg] (lb)
HF-SP121	1.2	38.3 (209)	12 (26.5)
HF-SP202	2.0		13 (28.7)
HF-SP2024			

[Unit: mm]

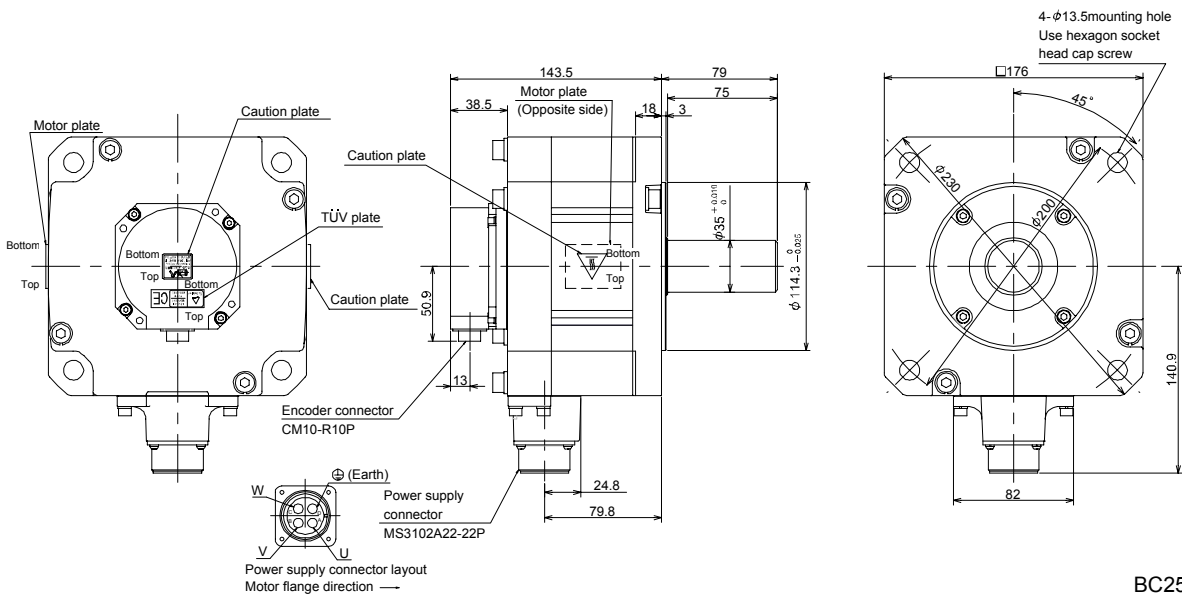

BC25938\*

# 7. HF-SP SERIES

Model	Output [kW]	Inertia moment J [ $\times 10^{-4}$ kg · m <sup>2</sup> ] (WK <sup>2</sup> [oz · in <sup>2</sup> ])	Mass [kg] (lb)
HF-SP201	2.0	75.0 (410)	19 (41.9)
HF-SP352	3.5		
HF-SP3524			

[Unit: mm]

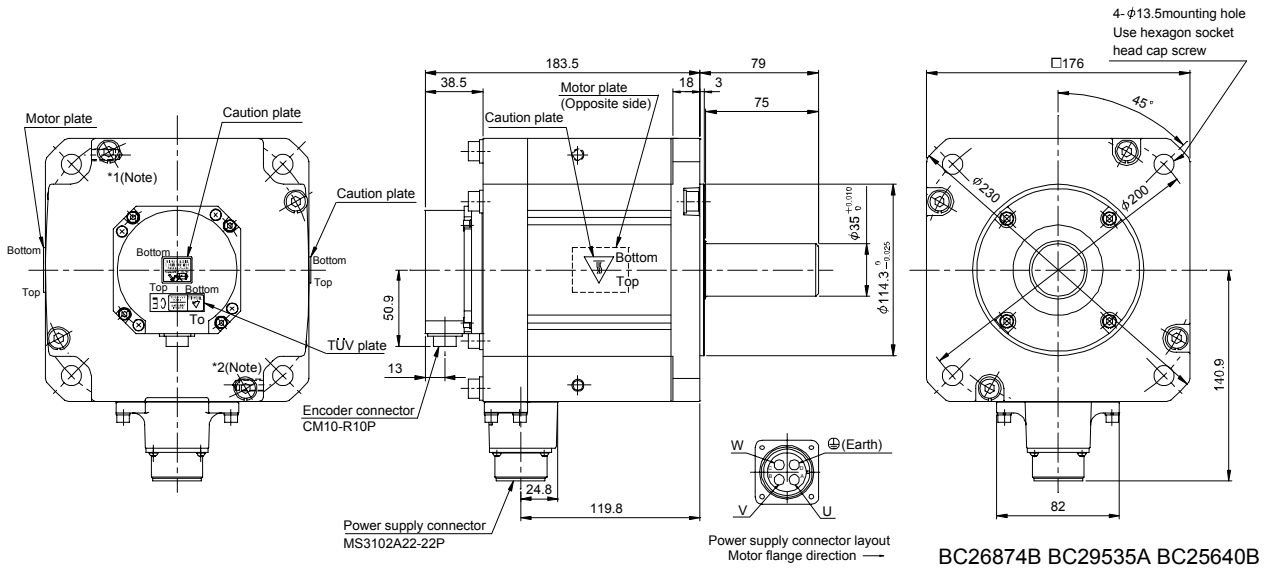

Note. \*1 and \*2 are screw hole for eyebolt (M8).

Model	Output [kW]	Inertia moment J [ $\times 10^{-4}$ kg · m <sup>2</sup> ] (WK <sup>2</sup> [oz · in <sup>2</sup> ])	Mass [kg] (lb)
HF-SP301	3.0	97 (530)	22 (48.5)
HF-SP502	5.0		
HF-SP5024			

[Unit: mm]

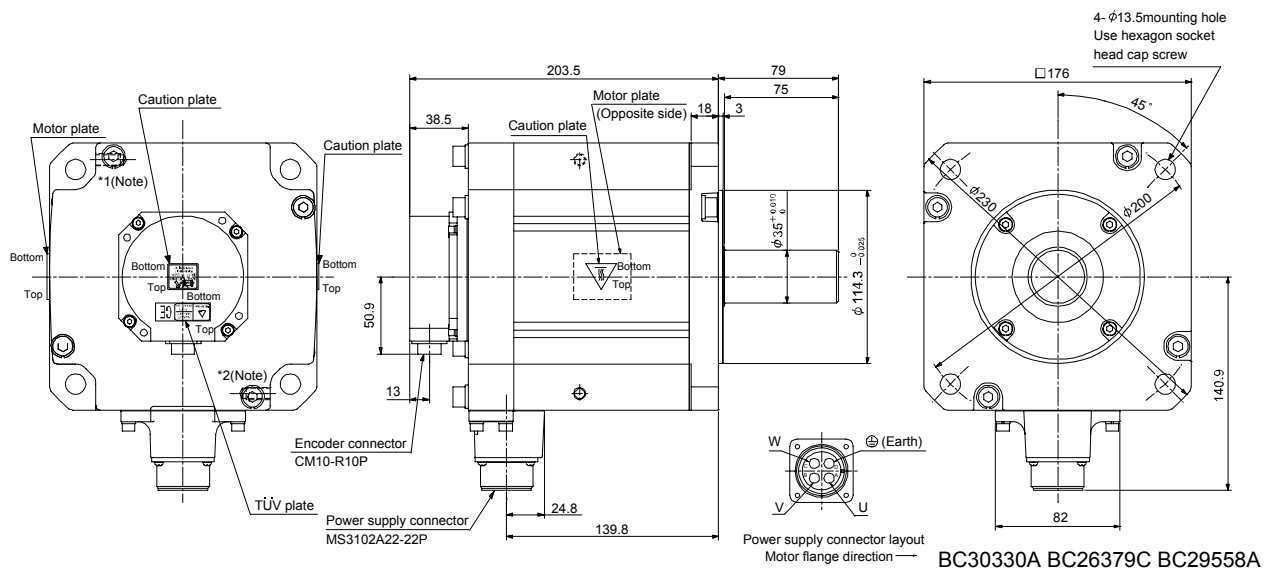

Note. \*1 and \*2 are screw hole for eyebolt (M8).

## 7. HF-SP SERIES

Model	Output [kW]	Inertia moment J [ $\times 10^{-4}$ kg · m <sup>2</sup> ] (WK <sup>2</sup> [oz · in <sup>2</sup> ])	Mass [kg] (lb)
HF-SP421	4.2	154 (842)	32 (70.6)
HF-SP702	7.0		
HF-SP7024			

[Unit: mm]

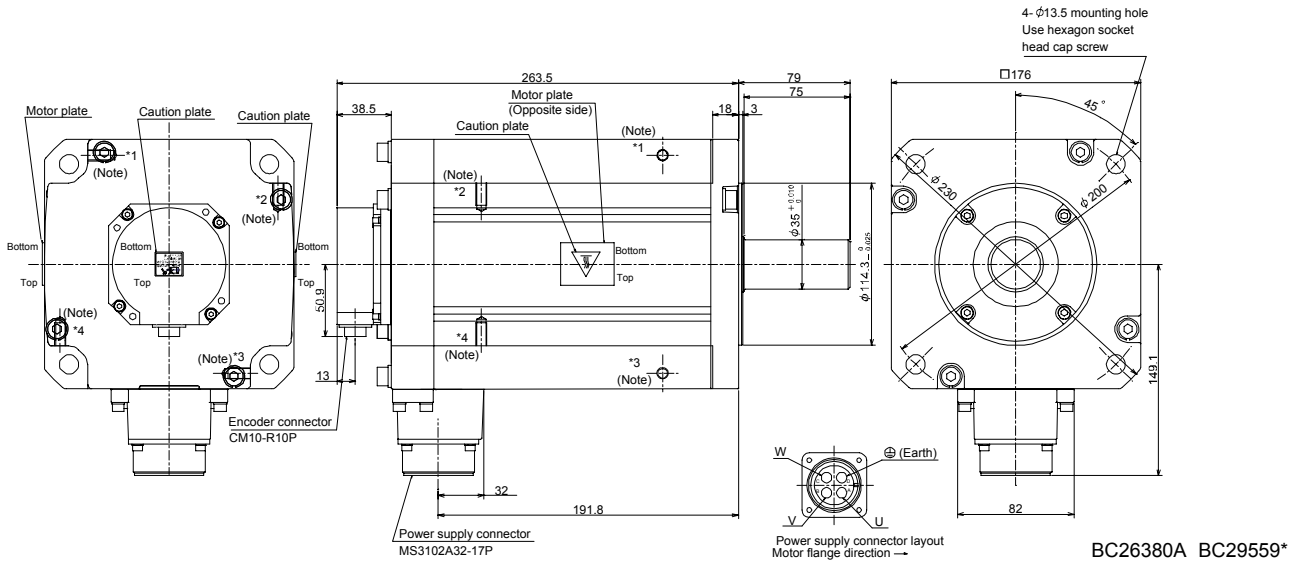

Note. \*1, \*2, \*3 and \*4 are screw hole for eyebolt (M8).

### 7.8.2 With an electromagnetic brake

Model	Output [kW]	Brake static friction torque [N · m] (oz · in)	Inertia moment J [ $\times 10^{-4}$ kg · m <sup>2</sup> ] (WK <sup>2</sup> [oz · in <sup>2</sup> ])	Mass [kg] (lb)
HF-SP52B	0.5	8.5 (1200)	8.3 (45.4)	6.7 (14.8)
HF-SP524B				

[Unit: mm]

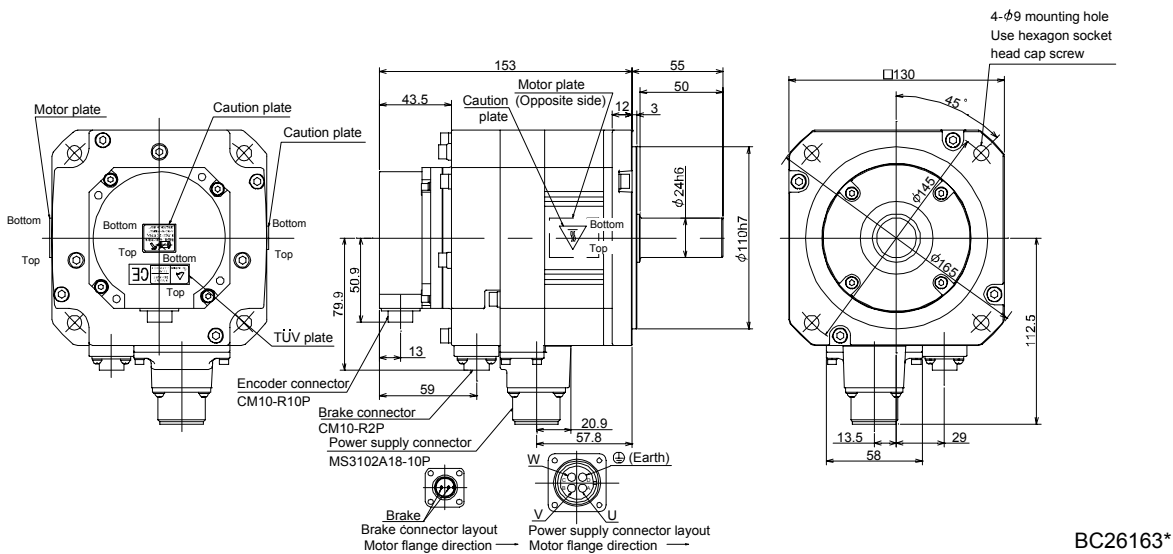

# 7. HF-SP SERIES

Model	Output [kW]	Brake static friction torque [N · m] (oz · in)	Inertia moment $J [ \times 10^{-4} \text{kg} \cdot \text{m}^2 ]$ (WK <sup>2</sup> [oz · in <sup>2</sup> ])	Mass [kg] (lb)
HF-SP51B	0.5	8.5 (1200)	14.0 (76.5)	8.5 (18.7)
HF-SP102B	1.0			
HF-SP1024B				8.6 (19.0)

[Unit: mm]

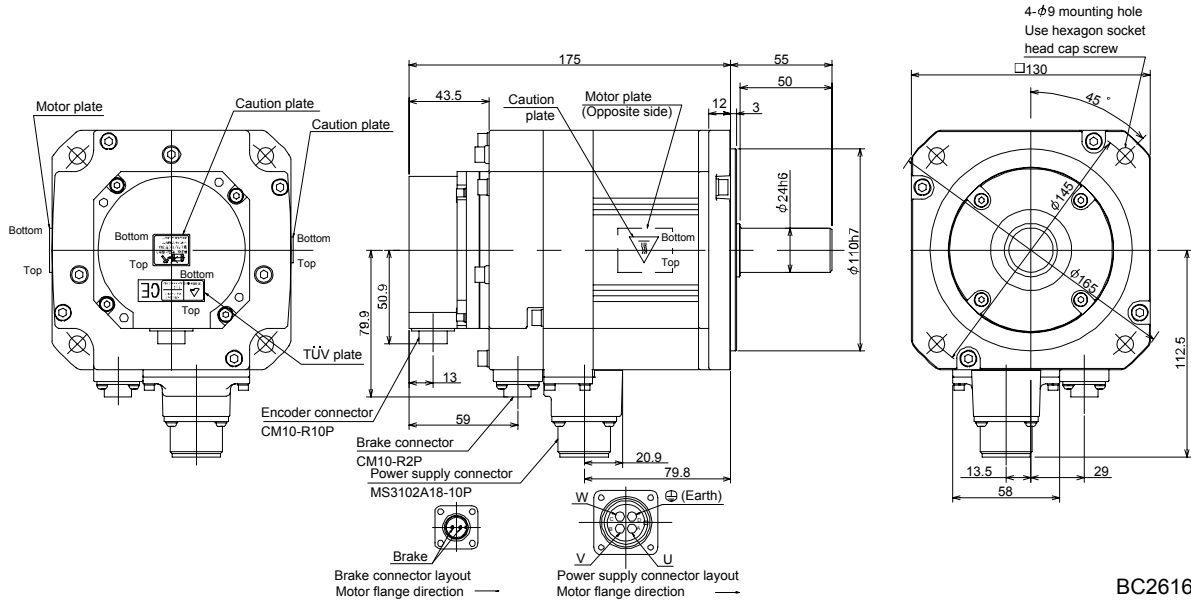

BC26164\*

Model	Output [kW]	Brake static friction torque [N · m] (oz · in)	Inertia moment $J [ \times 10^{-4} \text{kg} \cdot \text{m}^2 ]$ (WK <sup>2</sup> [oz · in <sup>2</sup> ])	Mass [kg] (lb)
HF-SP81B	0.85	8.5 (1200)	20.0 (109)	10.3 (22.7)
HF-SP152B	1.5			
HF-SP1524B				11 (24.3)

[Unit: mm]

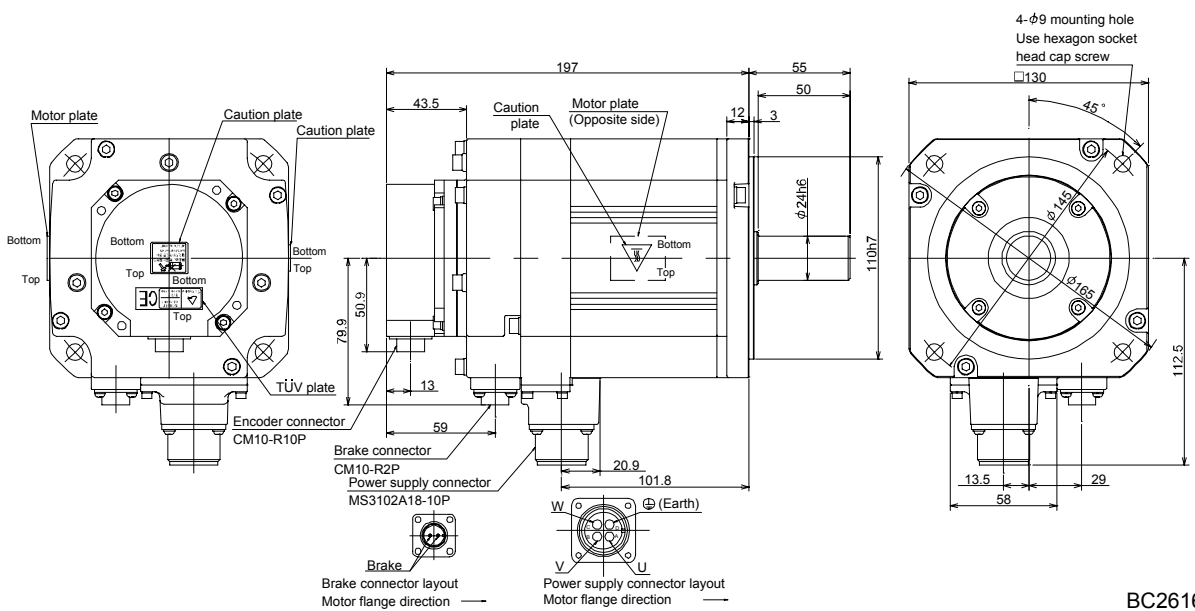

BC26165\*

# 7. HF-SP SERIES

Model	Output [kW]	Brake static friction torque [N · m] (oz · in)	Inertia moment $J [ \times 10^{-4} \text{kg} \cdot \text{m}^2 ]$ (WK <sup>2</sup> [oz · in <sup>2</sup> ])	Mass [kg] (lb)
HF-SP121B	1.2	44 (6230)	47.9 (262)	18 (39.7)
HF-SP202B	2.0			19 (41.9)
HF-SP2024B				

[Unit: mm]

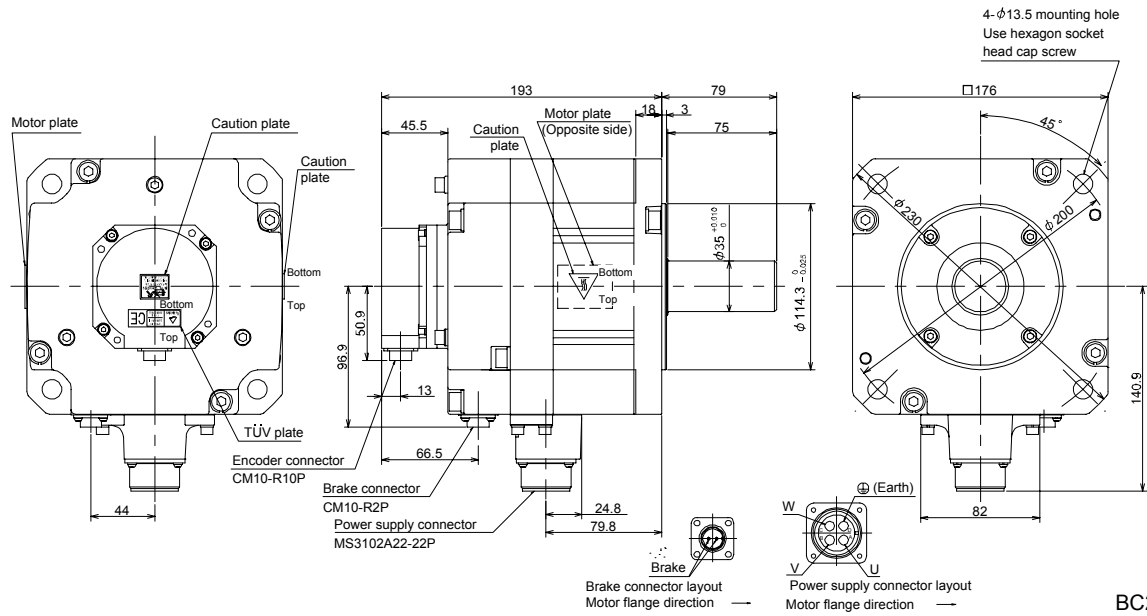

BC25987\*

Model	Output [kW]	Brake static friction torque [N · m] (oz · in)	Inertia moment $J [ \times 10^{-4} \text{kg} \cdot \text{m}^2 ]$ (WK <sup>2</sup> [oz · in <sup>2</sup> ])	Mass [kg] (lb)
HF-SP201B	2.0	44 (6230)	84.7 (463)	25 (55.1)
HF-SP352B	3.5			25 (55.1)
HF-SP3524B				

[Unit: mm]

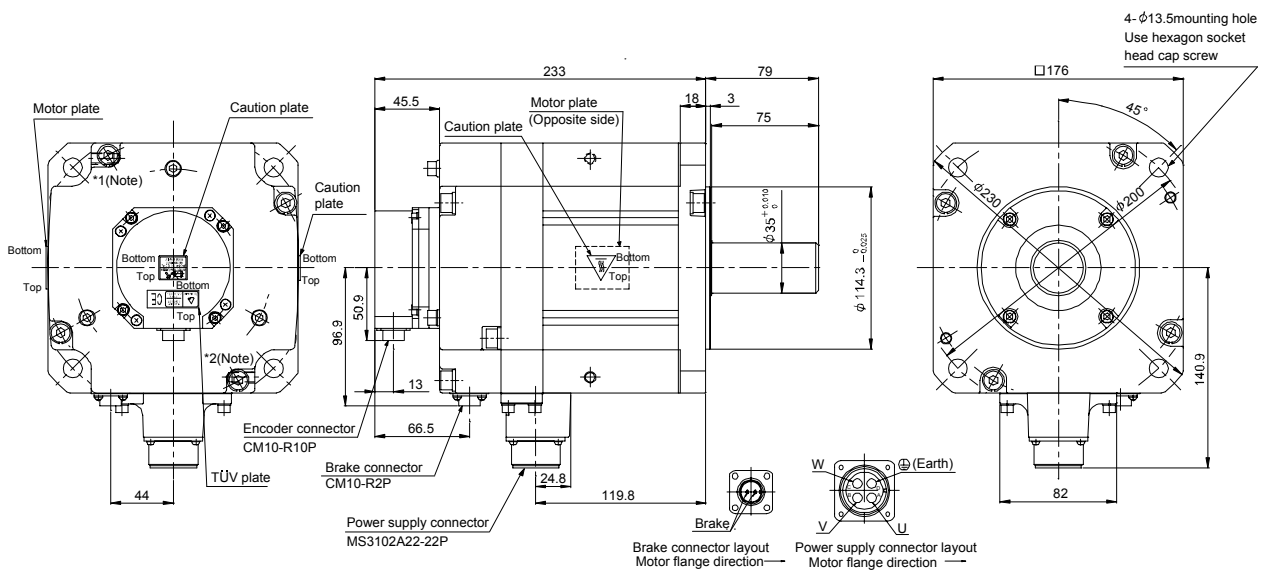

BC26878B BC29540A BC25641C

Note. \*1 and \*2 are screw hole for eyebolt (M8).

# 7. HF-SP SERIES

Model	Output [kW]	Brake static friction torque [N · m] (oz · in)	Inertia moment $J [ \times 10^{-4} \text{kg} \cdot \text{m}^2 ]$ (WK <sup>2</sup> [oz · in <sup>2</sup> ])	Mass [kg] (lb)
HF-SP301B	3.0	44 (6230)	107 (585)	28 (61.7)
HF-SP502B	5.0			
HF-SP5024B				

[Unit: mm]

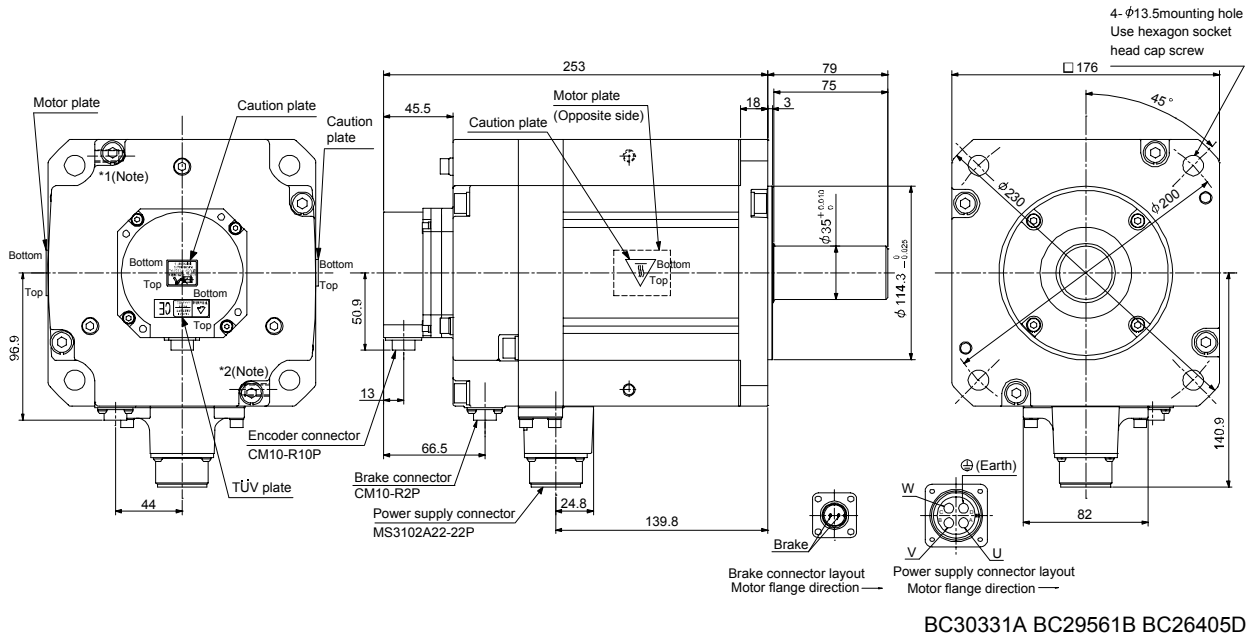

Note. \*1 and \*2 are screw hole for eyebolt (M8).

Model	Output [kW]	Brake static friction torque [N · m] (oz · in)	Inertia moment $J [ \times 10^{-4} \text{kg} \cdot \text{m}^2 ]$ (WK <sup>2</sup> [oz · in <sup>2</sup> ])	Mass [kg] (lb)
HF-SP421B	4.2	44 (6230)	164 (897)	38 (83.8)
HF-SP702B	7.0			
HF-SP7024B				

[Unit: mm]

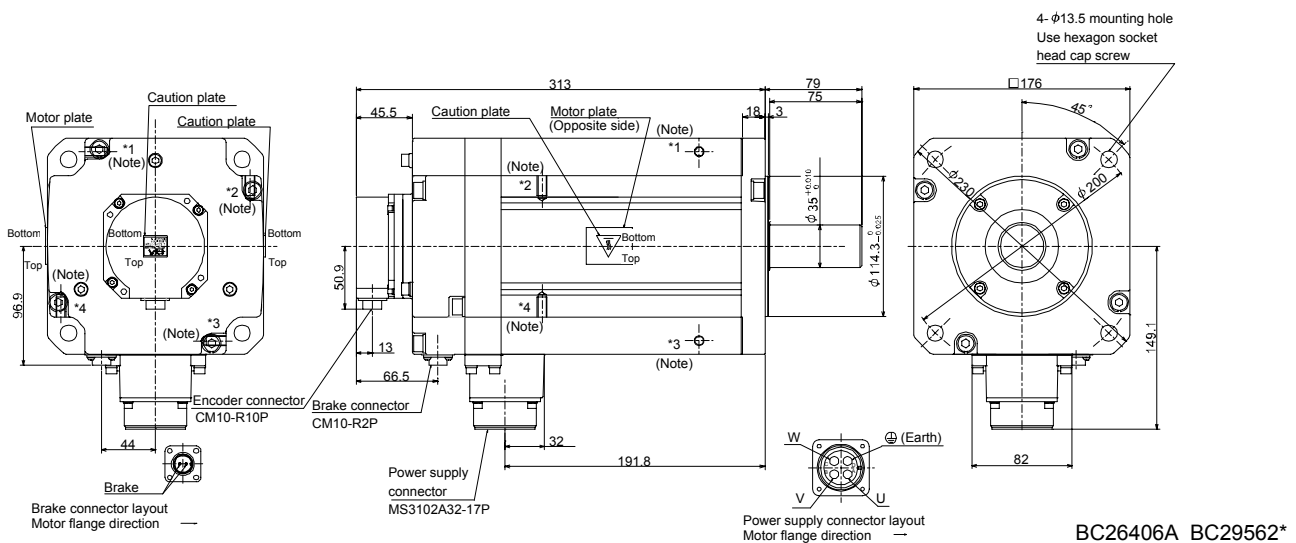

Note. \*1, \*2, \*3 and \*4 are screw hole for eyebolt (M8).



## 7. HF-SP SERIES

### 7.8.3 For general industrial machine with a reduction gear (without an electromagnetic brake)

Model	Output [kW]	Reduction gear frame number	Reduction ratio (Actual reduction ratio)	Inertia moment $J [\times 10^{-4} \text{kg} \cdot \text{m}^2] (\text{WK}^2 [\text{oz} \cdot \text{in}^2])$	Mass [kg] (lb)
HF-SP52G1 HF-SP524G1	0.5	6100	1/6	7.10 (38.8)	18.3 (40.3)
			1/11	6.70 (36.6)	
			1/17	6.60 (36.1)	
			1/29	6.50 (35.5)	

[Unit: mm]

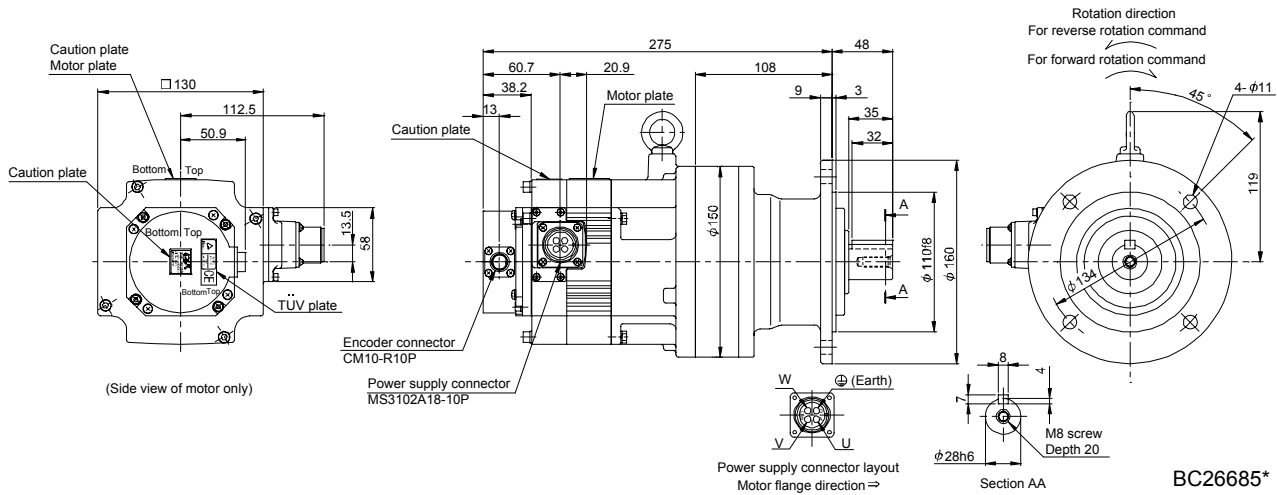

Model	Output [kW]	Reduction gear frame number	Reduction ratio (Actual reduction ratio)	Inertia moment $J [\times 10^{-4} \text{kg} \cdot \text{m}^2] (\text{WK}^2 [\text{oz} \cdot \text{in}^2])$	Mass [kg] (lb)
HF-SP52G1 HF-SP524G1	0.5	6120	1/35	7.30 (39.9)	26.8 (59.1)
			1/43		
			1/59	7.20 (39.4)	

[Unit: mm]

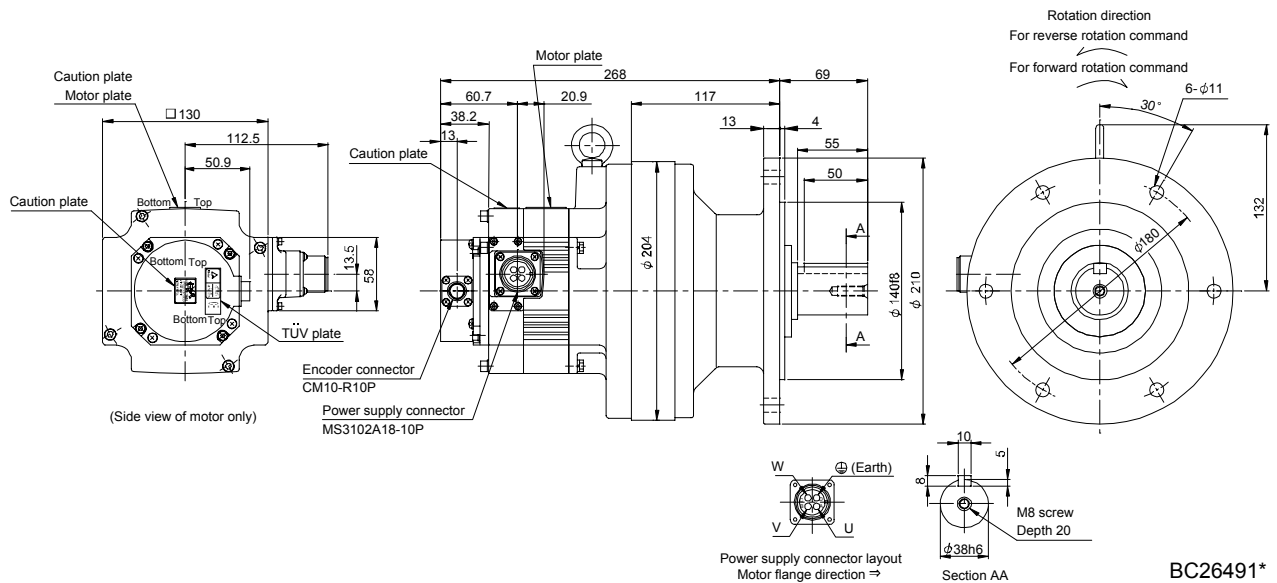

# 7. HF-SP SERIES

Model	Output [kW]	Reduction gear frame number	Reduction ratio (Actual reduction ratio)	Inertia moment $J [\times 10^{-4} \text{kg} \cdot \text{m}^2]$ (WK <sup>2</sup> [oz · in <sup>2</sup> ])	Mass [kg] (lb)
HF-SP102G1 HF-SP1024G1	1.0	6120	1/6	15.4 (84.2)	28.5 (62.8)
			1/11	13.9 (76.0)	
			1/17	13.5 (73.8)	
			1/29	13.2 (72.2)	
			1/35		

[Unit: mm]

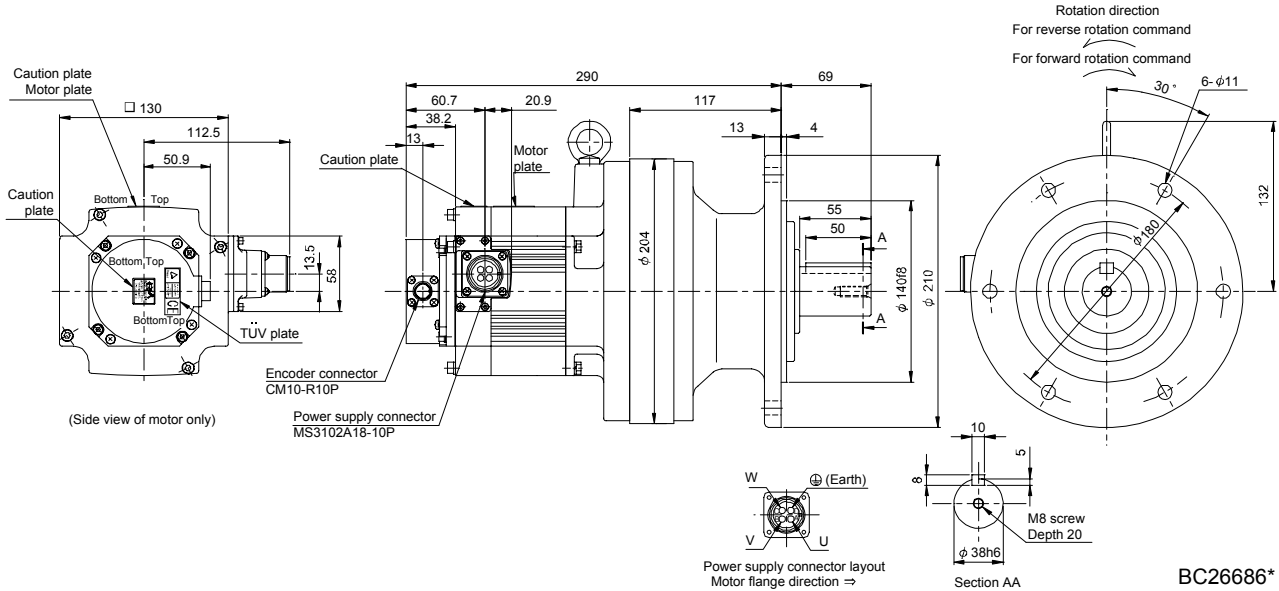

Model	Output [kW]	Reduction gear frame number	Reduction ratio (Actual reduction ratio)	Inertia moment $J [\times 10^{-4} \text{kg} \cdot \text{m}^2]$ (WK <sup>2</sup> [oz · in <sup>2</sup> ])	Mass [kg] (lb)
HF-SP102G1 HF-SP1024G1	1.0	6120	1/43	14.3 (78.2)	47.5 (105)

[Unit: mm]

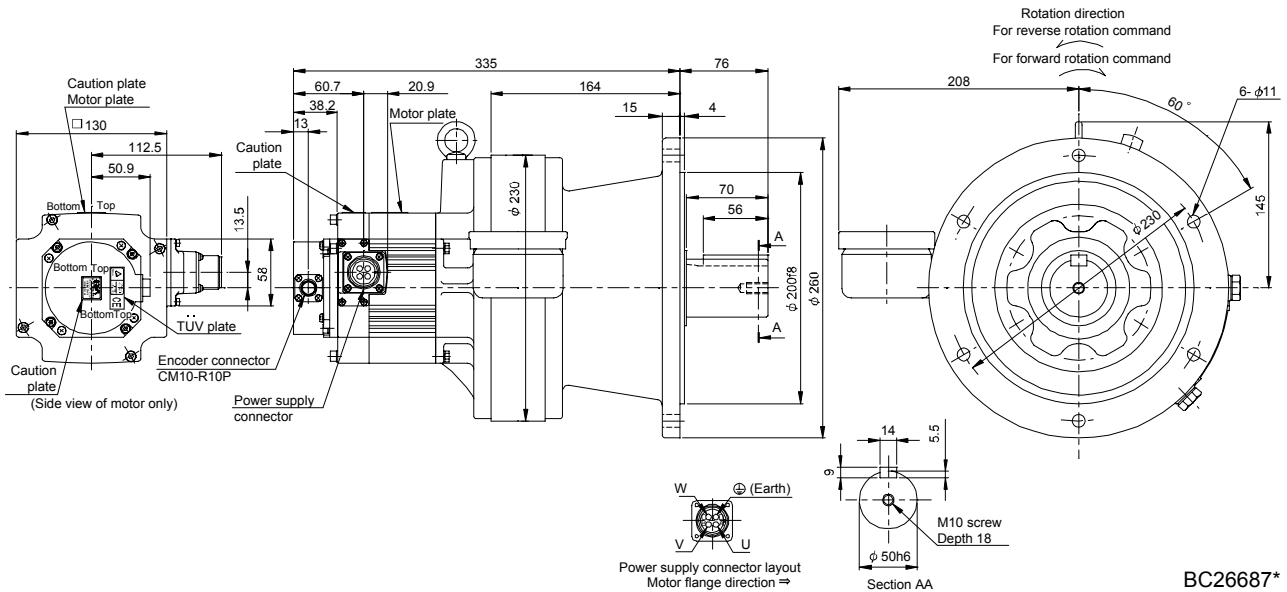

# 7. HF-SP SERIES

Model	Output [kW]	Reduction gear frame number	Reduction ratio (Actual reduction ratio)	Inertia moment $J [\times 10^{-4} \text{kg} \cdot \text{m}^2]$ ( $\text{WK}^2 [\text{oz} \cdot \text{in}^2]$ )	Mass [kg] ([lb])
HF-SP102G1 HF-SP1024G1	1.0	6160	1/59	20.3 (111)	82.5 (182)

[Unit: mm]

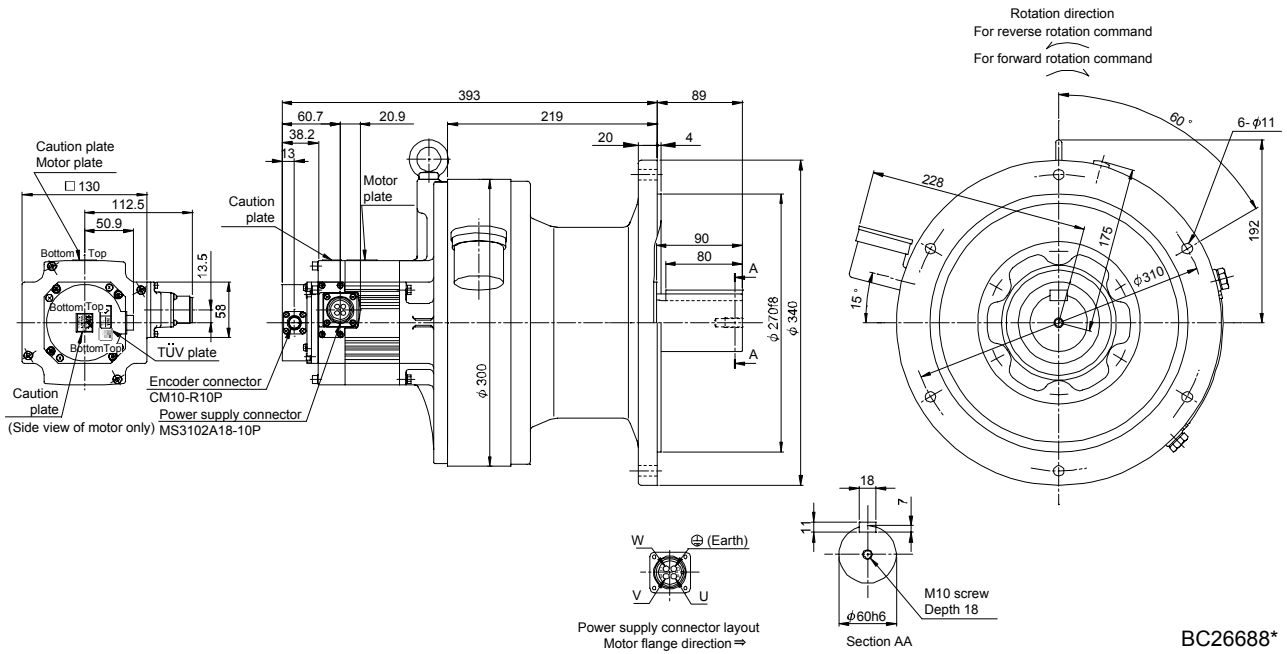

Model	Output [kW]	Reduction gear frame number	Reduction ratio (Actual reduction ratio)	Inertia moment $J [\times 10^{-4} \text{kg} \cdot \text{m}^2]$ ( $\text{WK}^2 [\text{oz} \cdot \text{in}^2]$ )	Mass [kg] ([lb])
HF-SP152G1 HF-SP1524G1	1.5	6120	1/6	21.3 (116)	30.3 (66.8)
			1/11	19.8 (108)	
			1/17	19.4 (106)	

[Unit: mm]

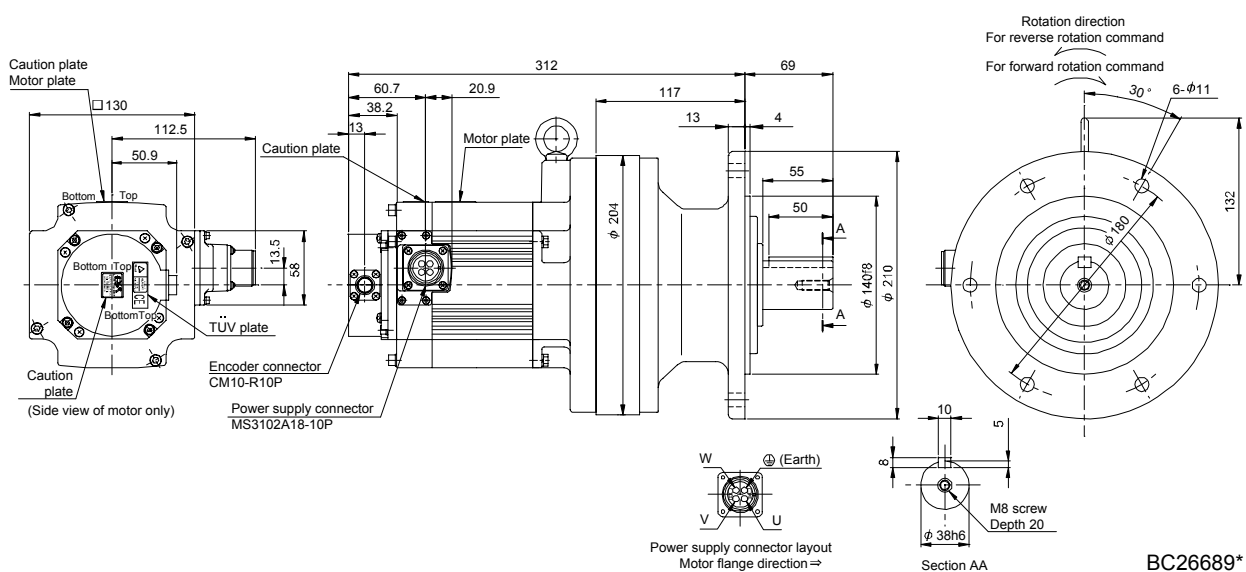

# 7. HF-SP SERIES

Model	Output [kW]	Reduction gear frame number	Reduction ratio (Actual reduction ratio)	Inertia moment J [ $\times 10^{-4}$ kg · m <sup>2</sup> ] (WK <sup>2</sup> [oz · in <sup>2</sup> ])	Mass [kg] ([lb])
HF-SP152G1	1.5	6130	1/29	20.4 (112)	49.3 (109)
HF-SP1524G1			1/35		

[Unit: mm]

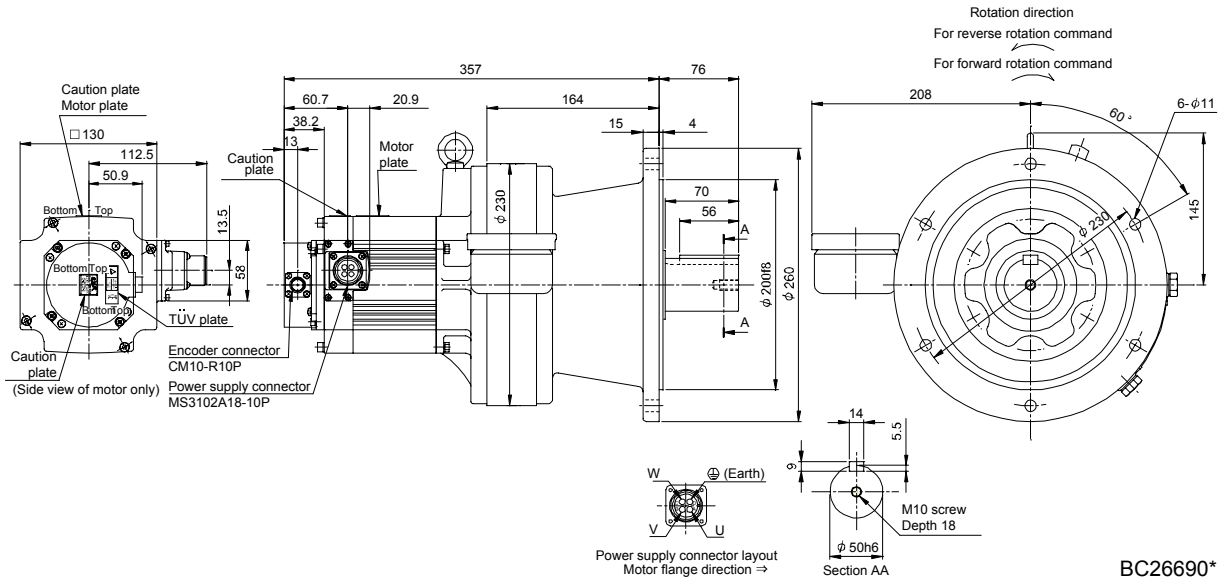

Model	Output [kW]	Reduction gear frame number	Reduction ratio (Actual reduction ratio)	Inertia moment J [ $\times 10^{-4}$ kg · m <sup>2</sup> ] (WK <sup>2</sup> [oz · in <sup>2</sup> ])	Mass [kg] ([lb])
HF-SP152G1	1.5	6160	1/43	26.3 (144)	84.3 (186)
HF-SP1524G1			1/59		

[Unit: mm]

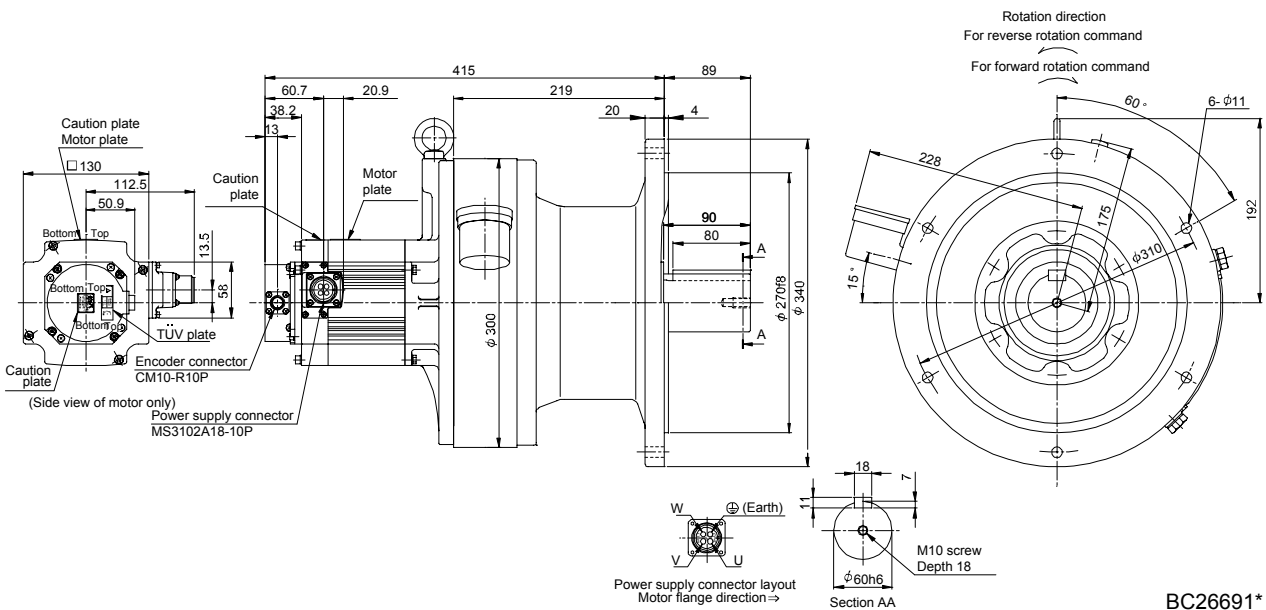

## 7. HF-SP SERIES

Model	Output [kW]	Reduction gear frame number	Reduction ratio (Actual reduction ratio)	Inertia moment $J [\times 10^{-4} \text{kg} \cdot \text{m}^2]$ ( $\text{WK}^2 [\text{oz} \cdot \text{in}^2]$ )	Mass [kg] ([lb])
HF-SP202G1 HF-SP2024G1	2.0	6120	1/6	42.1 (230)	34 (75.0)
			1/11	40.5 (221)	
			1/17	40.2 (220)	

[Unit: mm]

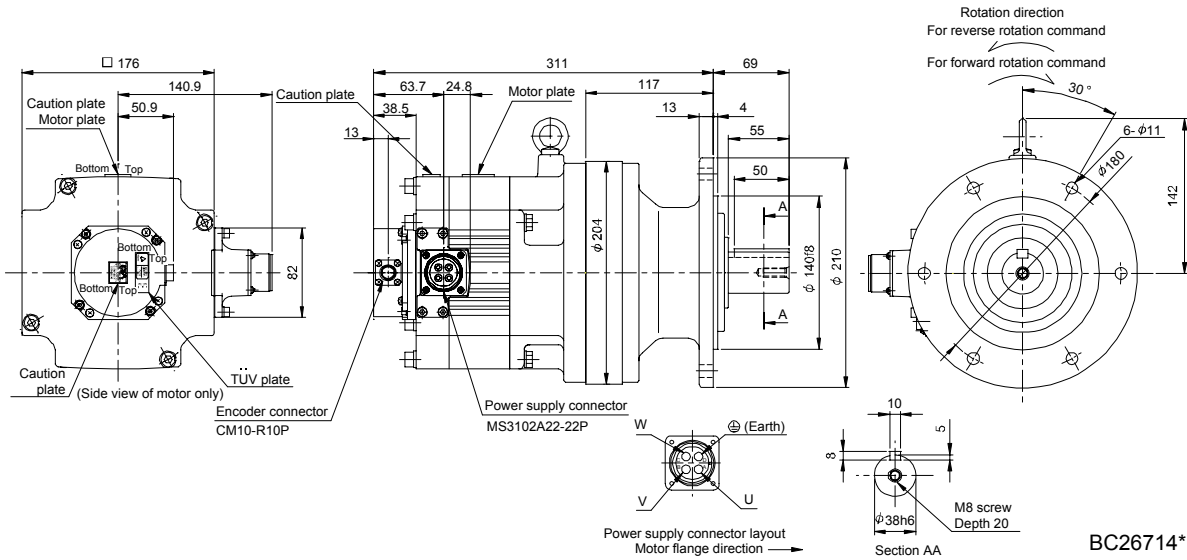

Model	Output [kW]	Reduction gear frame number	Reduction ratio (Actual reduction ratio)	Inertia moment $J [\times 10^{-4} \text{kg} \cdot \text{m}^2]$ ( $\text{WK}^2 [\text{oz} \cdot \text{in}^2]$ )	Mass [kg] ([lb])
HF-SP202G1 HF-SP2024G1	2.0	6165	1/29	46.9 (256)	84 (185)
			1/35	46.7 (255)	
			1/43	46.4 (254)	
			1/59		

[Unit: mm]

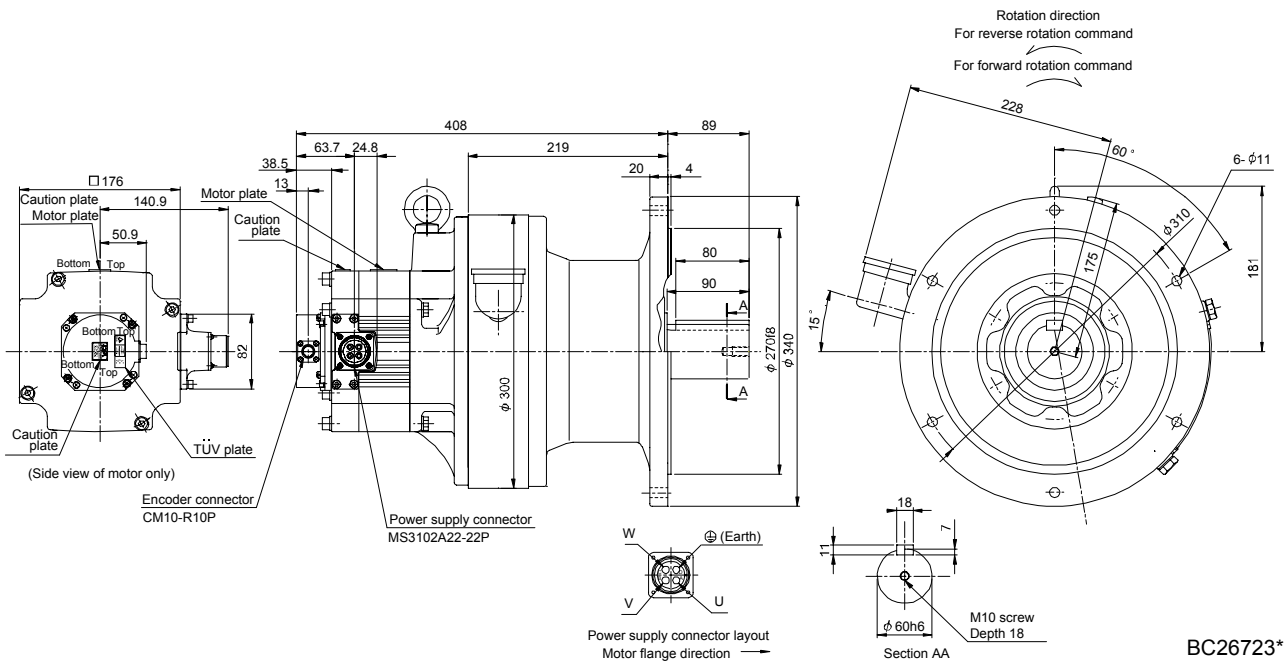

# 7. HF-SP SERIES

Model	Output [kW]	Reduction gear frame number	Reduction ratio (Actual reduction ratio)	Inertia moment $J [\times 10^{-4} \text{kg} \cdot \text{m}^2] (\text{WK}^2 [\text{oz} \cdot \text{in}^2])$	Mass [kg] (lb)
HF-SP352G1 HF-SP3524G1	3.5	6135	1/6	84.4 (461)	57 (126)
			1/11	80.1 (438)	
			1/17	78.8 (431)	

[Unit: mm]

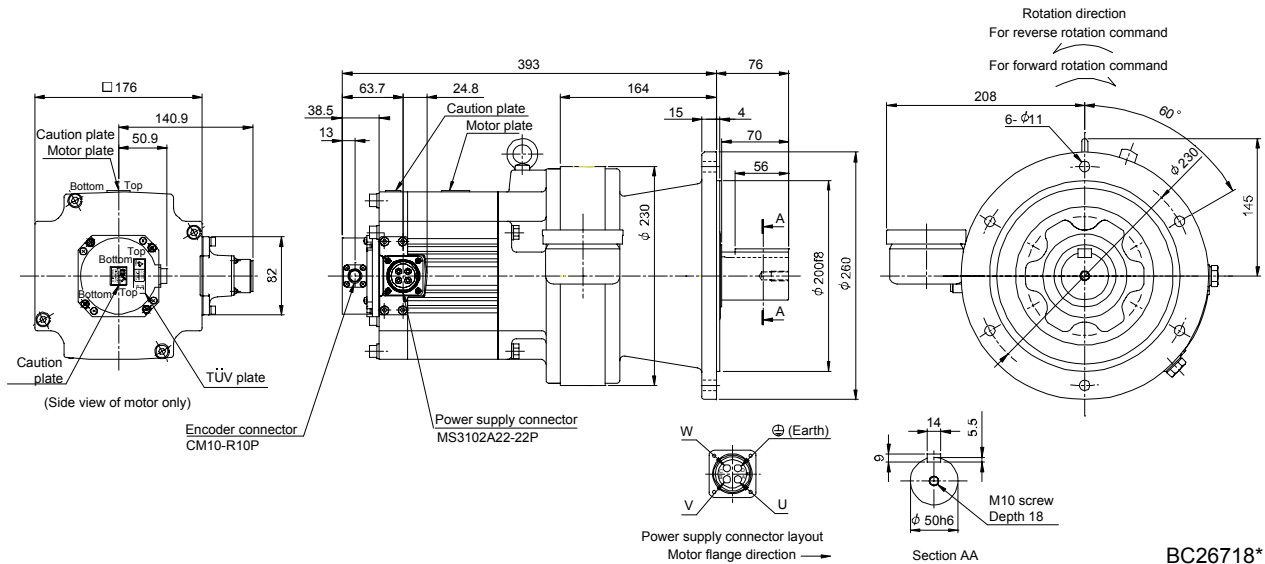

BC26718\*

Model	Output [kW]	Reduction gear frame number	Reduction ratio (Actual reduction ratio)	Inertia moment $J [\times 10^{-4} \text{kg} \cdot \text{m}^2] (\text{WK}^2 [\text{oz} \cdot \text{in}^2])$	Mass [kg] (lb)
HF-SP352G1 HF-SP3524G1	3.5	6165	1/29	83.9 (459)	91 (201)
			1/35	83.7 (458)	

[Unit: mm]

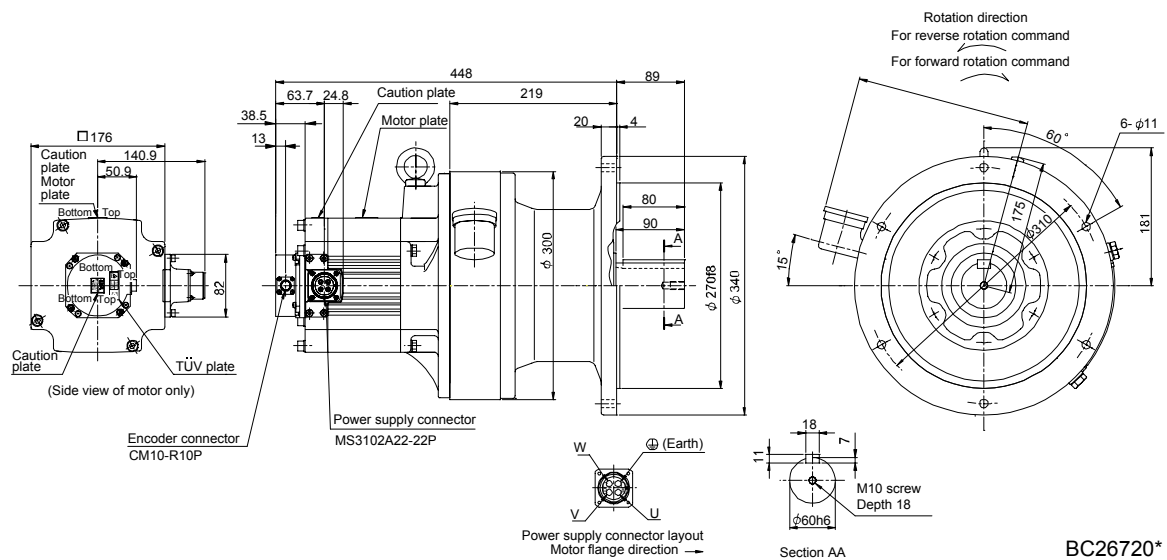

BC26720\*

# 7. HF-SP SERIES

Model	Output [kW]	Reduction gear frame number	Reduction ratio (Actual reduction ratio)	Inertia moment $J [\times 10^{-4} \text{kg} \cdot \text{m}^2] (\text{WK}^2 [\text{oz} \cdot \text{in}^2])$	Mass [kg] (lb)
HF-SP352G1	3.5	6175	1/43	101.9 (557)	133 (293)
HF-SP3524G1			1/59	101.3 (554)	

[Unit: mm]

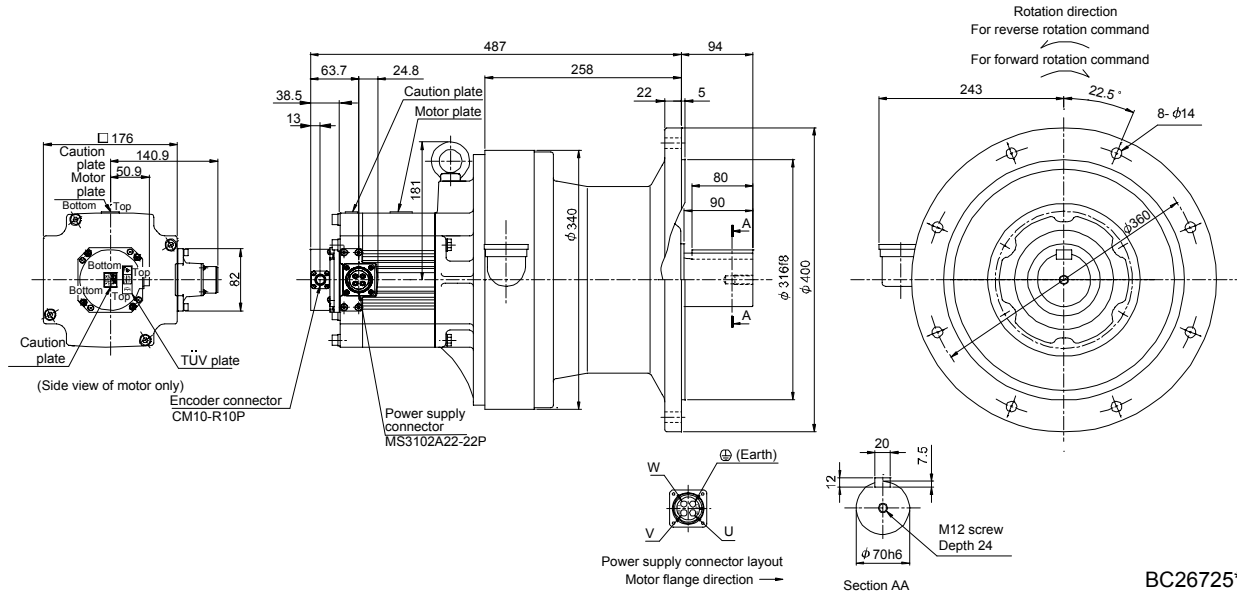

BC26725\*

Model	Output [kW]	Reduction gear frame number	Reduction ratio (Actual reduction ratio)	Inertia moment $J [\times 10^{-4} \text{kg} \cdot \text{m}^2] (\text{WK}^2 [\text{oz} \cdot \text{in}^2])$	Mass [kg] (lb)
HF-SP502G1	5.0	6165	1/6	121.2 (663)	95 (209)
HF-SP5024G1			1/11	108.9 (595)	
			1/17	104.8 (573)	

[Unit: mm]

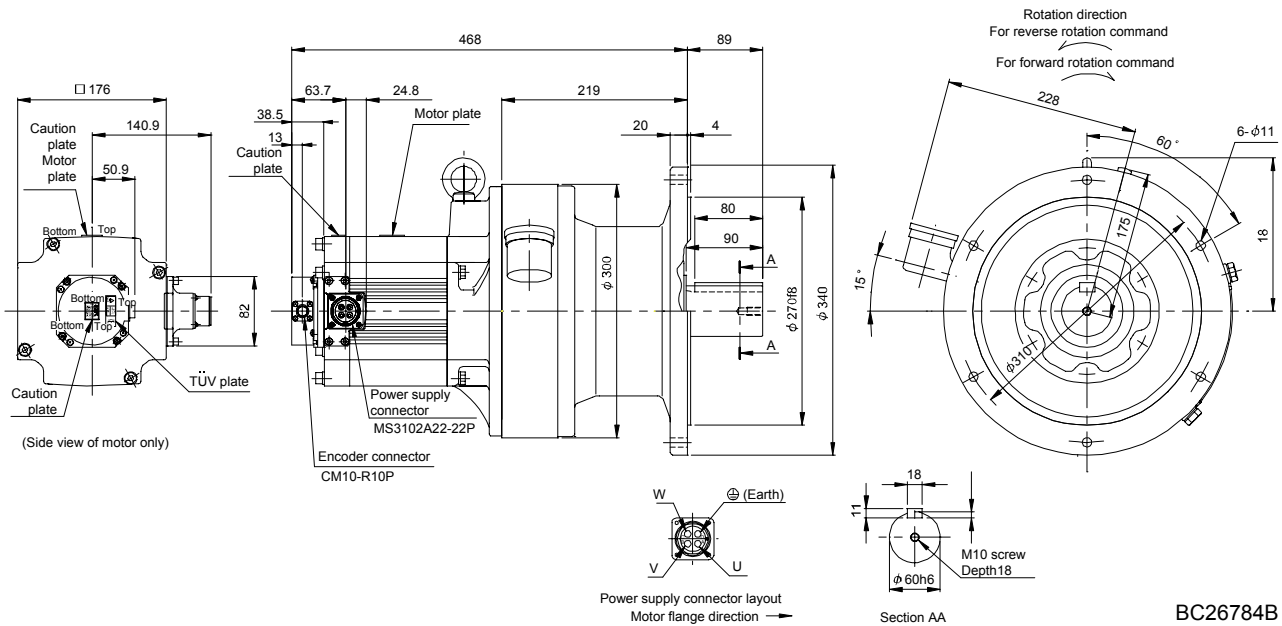

BC26784B

# 7. HF-SP SERIES

Model	Output [kW]	Reduction gear frame number	Reduction ratio (Actual reduction ratio)	Inertia moment $J [\times 10^{-4} \text{kg} \cdot \text{m}^2] (\text{WK}^2 [\text{oz} \cdot \text{in}^2])$	Mass [kg] (lb)
HF-SP502G1 HF-SP5024G1	5.0	6180	1/29	135.6 (741)	162 (357)
			1/35	135.1 (739)	
			1/43	134.1 (733)	

[Unit: mm]

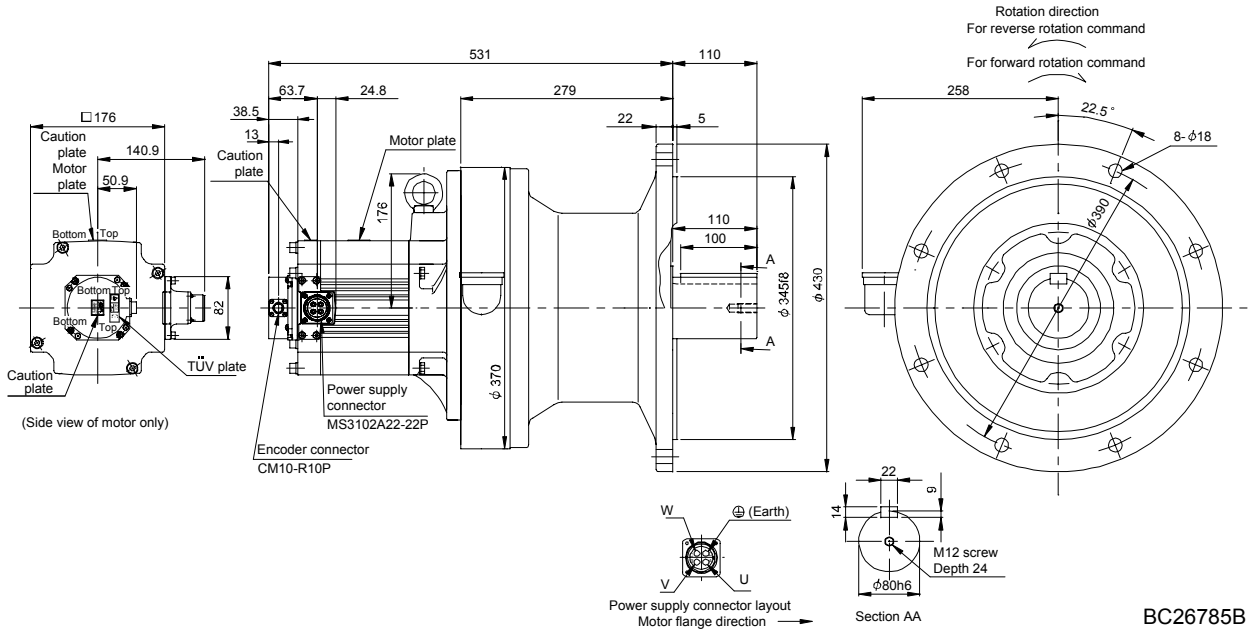

BC26785B

Model	Output [kW]	Reduction gear frame number	Reduction ratio (Actual reduction ratio)	Inertia moment $J [\times 10^{-4} \text{kg} \cdot \text{m}^2] (\text{WK}^2 [\text{oz} \cdot \text{in}^2])$	Mass [kg] (lb)
HF-SP502G1 HF-SP5024G1	5.0	6185	1/59	132.9 (727)	162 (357)

[Unit: mm]

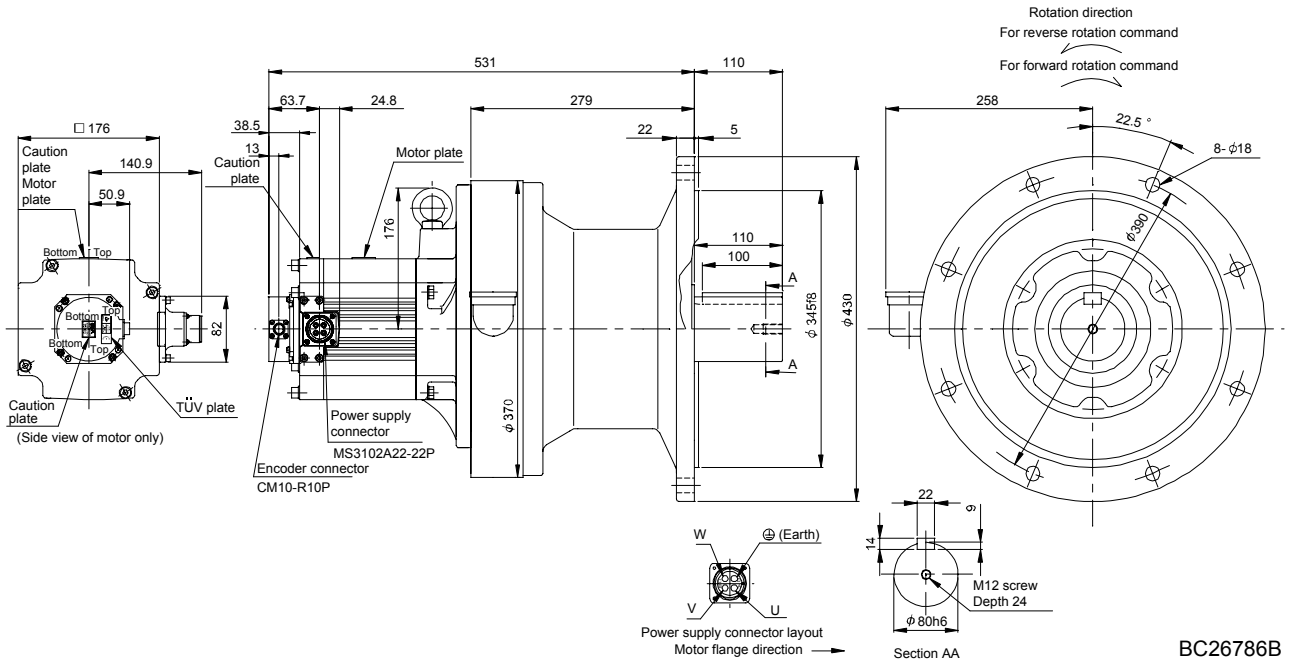

BC26786B



# 7. HF-SP SERIES

Model	Output [kW]	Reduction gear frame number	Reduction ratio (Actual reduction ratio)	Inertia moment $J [\times 10^{-4} \text{kg} \cdot \text{m}^2]$ ( $\text{WK}^2 [\text{oz} \cdot \text{in}^2]$ )	Mass [kg] ([lb])
HF-SP702G1 HF-SP7024G1	7.0	6165	1/6	177.4 (970)	104 (229)

[Unit: mm]

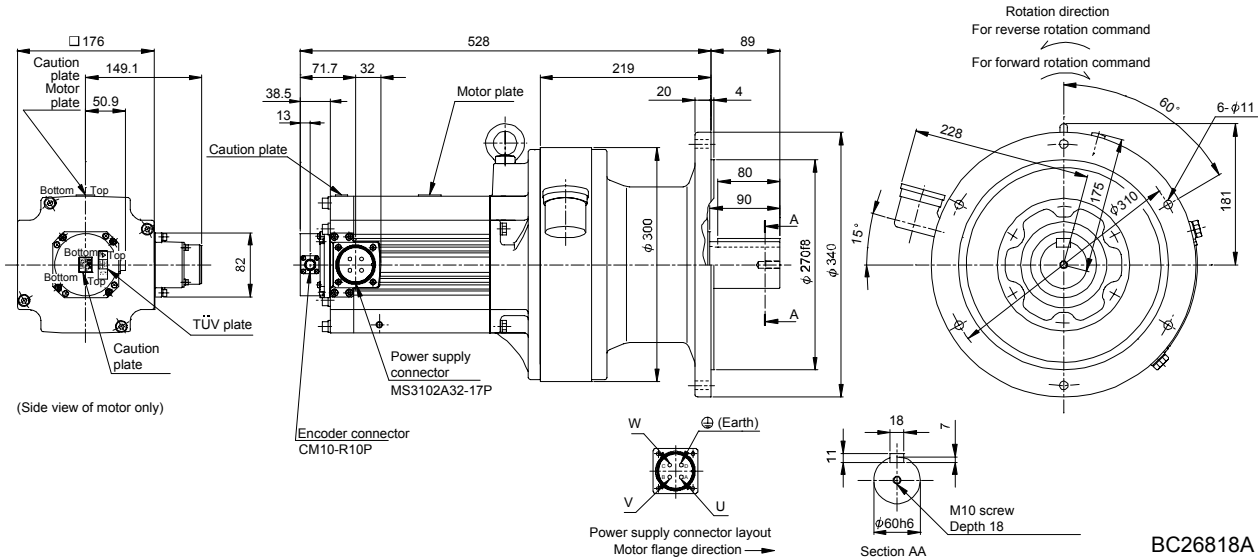

Model	Output [kW]	Reduction gear frame number	Reduction ratio (Actual reduction ratio)	Inertia moment $J [\times 10^{-4} \text{kg} \cdot \text{m}^2]$ ( $\text{WK}^2 [\text{oz} \cdot \text{in}^2]$ )	Mass [kg] ([lb])
HF-SP702G1	7.0	6170	1/11	190.2 (1040)	146 (322)
HF-SP7024G1			1/17	182.7 (999)	

[Unit: mm]

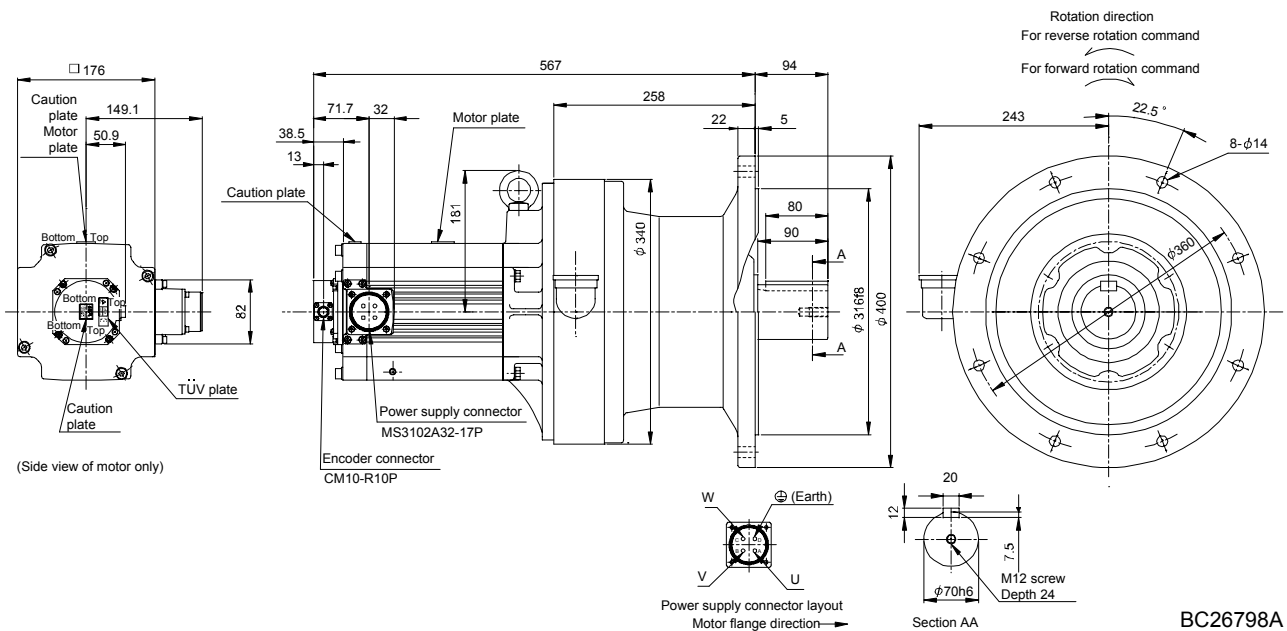

## 7. HF-SP SERIES

Model	Output [kW]	Reduction gear frame number	Reduction ratio (Actual reduction ratio)	Inertia moment $J [\times 10^{-4} \text{kg} \cdot \text{m}^2] (\text{WK}^2 [\text{oz} \cdot \text{in}^2])$	Mass [kg] ([lb])
HF-SP702G1	7.0	6180	1/29	192.3 (1050)	171 (377)
HF-SP7024G1			1/35	191.8 (1050)	

[Unit: mm]

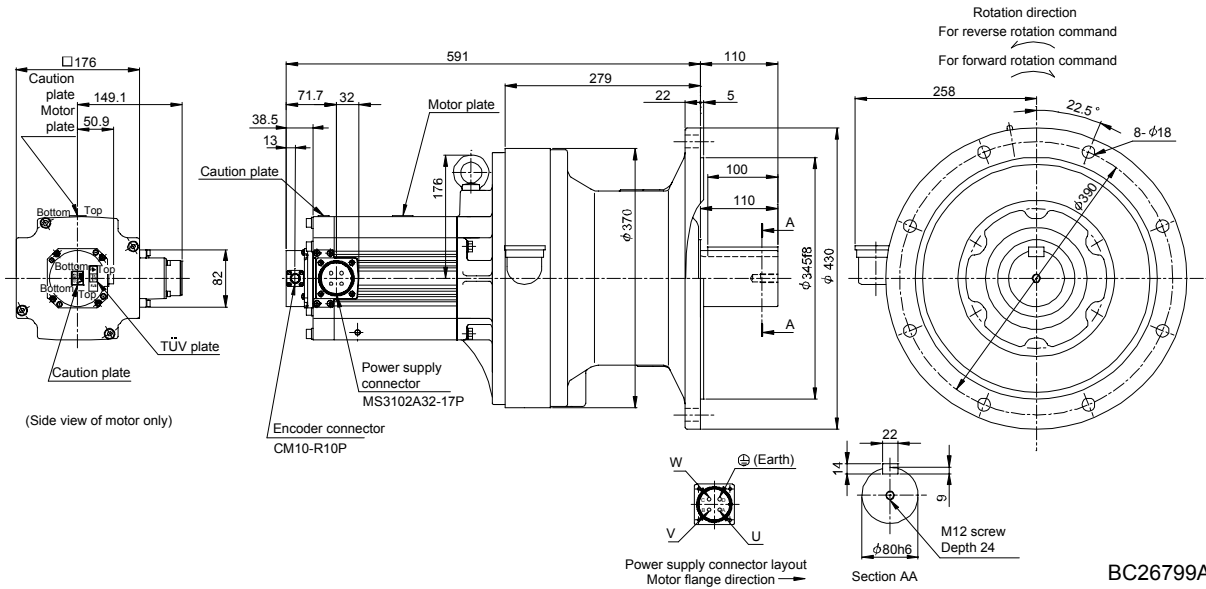

BC26799A

Model	Output [kW]	Reduction gear frame number	Reduction ratio (Actual reduction ratio)	Inertia moment $J [\times 10^{-4} \text{kg} \cdot \text{m}^2] (\text{WK}^2 [\text{oz} \cdot \text{in}^2])$	Mass [kg] ([lb])
HF-SP702G1	7.0	6195	1/43	269.8 (1480)	240 (529)
HF-SP7024G1			1/59	268.0 (1470)	

[Unit: mm]

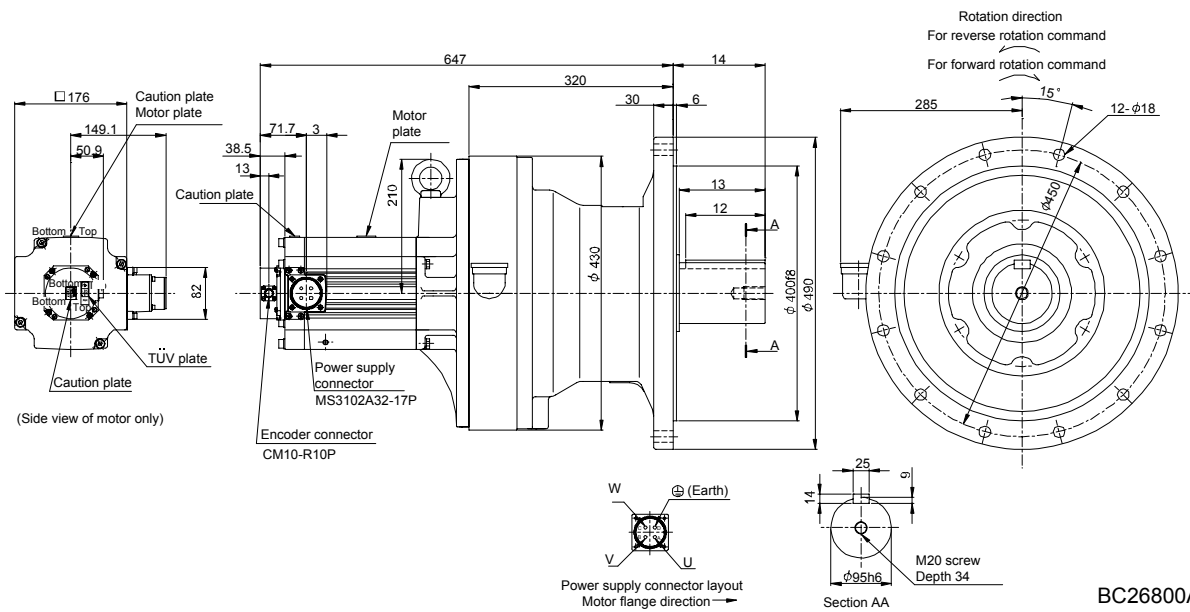

BC26800A

## 7. HF-SP SERIES

### 7.8.4 For general industrial machine with a reduction gear (with an electromagnetic brake)

Model	Output [kW]	Reduction gear frame number	Reduction ratio (Actual reduction ratio)	Brake static friction torque [N · m] ([oz · in])	Inertia moment J [ $\times 10^{-4} \text{kg} \cdot \text{m}^2$ ] ( $\text{WK}^2$ [oz · in <sup>2</sup> ])	Mass [kg] ([lb])
HF-SP52BG1 HF-SP524BG1	0.5	6100	1/6	8.5 (1200)	9.30 (50.8)	20.2 (44.5)
			1/11		8.80 (48.1)	
			1/17		8.70 (47.6)	
			1/29			

[Unit: mm]

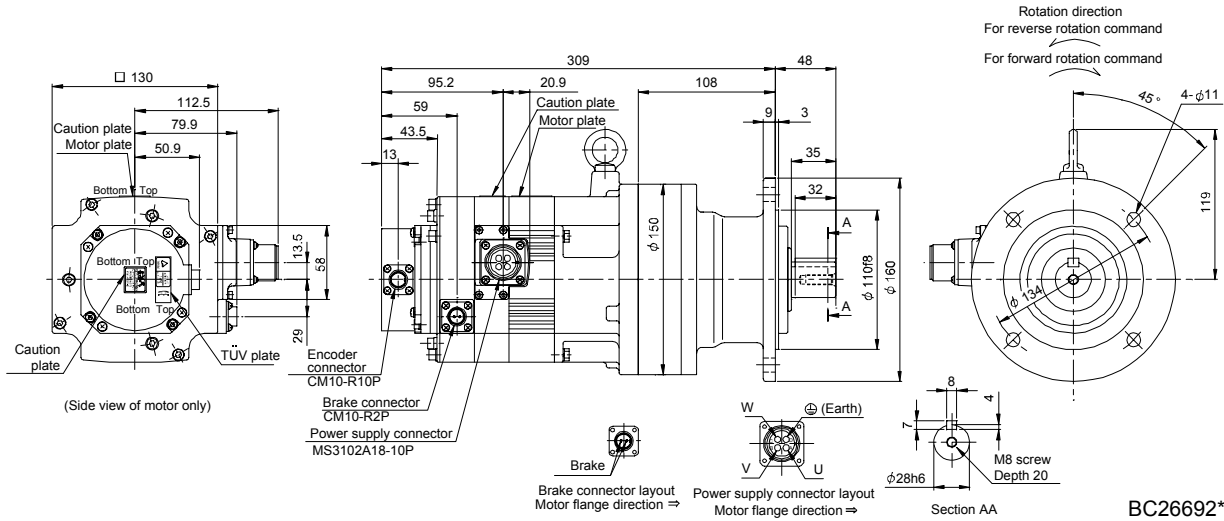

Model	Output [kW]	Reduction gear frame number	Reduction ratio (Actual reduction ratio)	Brake static friction torque [N · m] ([oz · in])	Inertia moment J [ $\times 10^{-4} \text{kg} \cdot \text{m}^2$ ] ( $\text{WK}^2$ [oz · in <sup>2</sup> ])	Mass [kg] ([lb])
HF-SP52BG1 HF-SP524BG1	0.5	6120	1/35	8.5 (1200)	9.40 (51.4)	28.7 (63.3)
			1/43			
			1/59			

[Unit: mm]

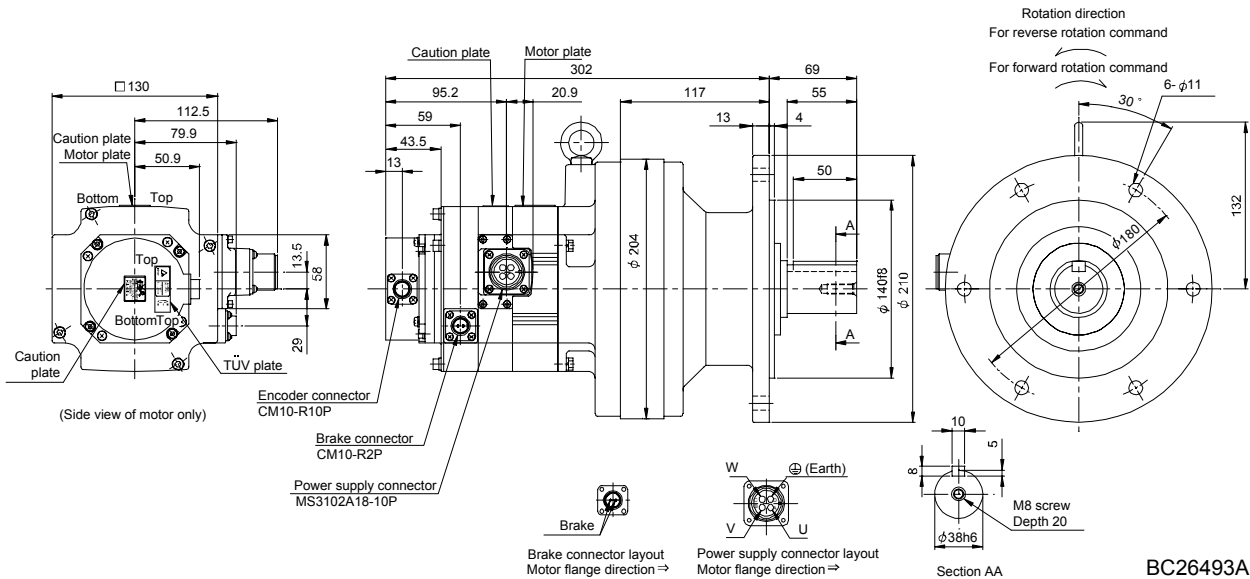

# 7. HF-SP SERIES

Model	Output [kW]	Reduction gear frame number	Reduction ratio (Actual reduction ratio)	Brake static friction torque [N · m] ([oz · in])	Inertia moment J [ $\times 10^{-4}$ kg · m <sup>2</sup> ] (WK <sup>2</sup> [oz · in <sup>2</sup> ])	Mass [kg] ([lb])
HF-SP102BG1 HF-SP1024BG1	1.0	6120	1/6	8.5 (1200)	17.5 (95.7)	30.5 (67.2)
			1/11		16.0 (87.5)	
			1/17		15.6 (85.3)	
			1/29		15.3 (83.7)	
			1/35			

[Unit: mm]

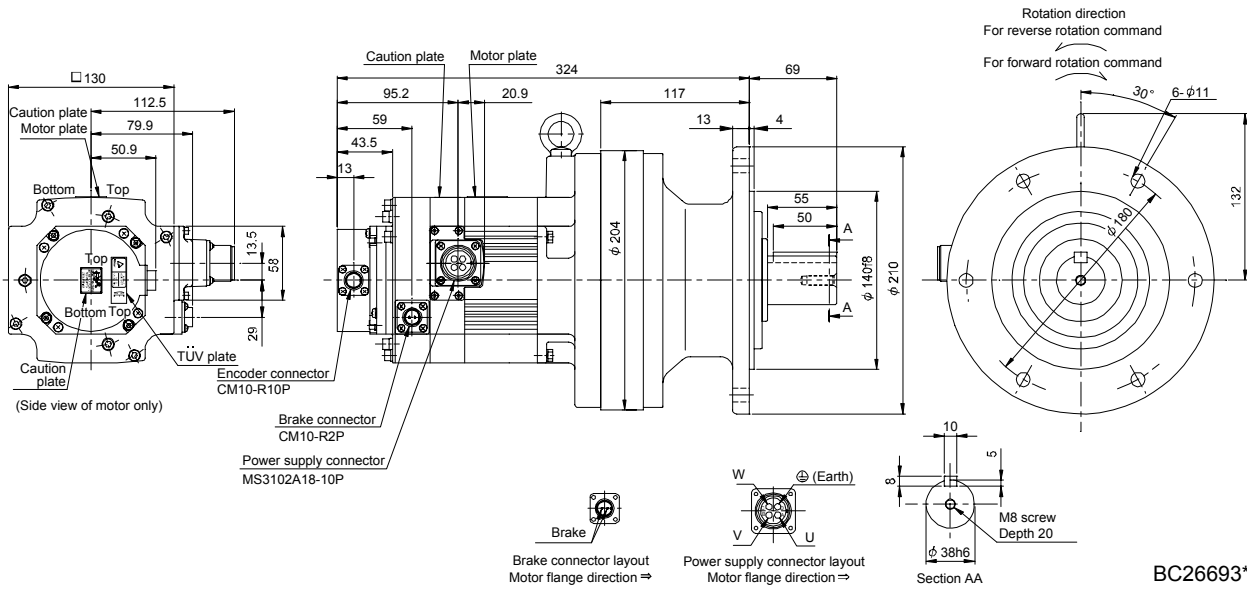

Model	Output [kW]	Reduction gear frame number	Reduction ratio (Actual reduction ratio)	Brake static friction torque [N · m] ([oz · in])	Inertia moment J [ $\times 10^{-4}$ kg · m <sup>2</sup> ] (WK <sup>2</sup> [oz · in <sup>2</sup> ])	Mass [kg] ([lb])
HF-SP102BG1 HF-SP1024BG1	1.0	6130	1/43	8.5 (1200)	16.5 (90.2)	49.5 (109)

[Unit: mm]

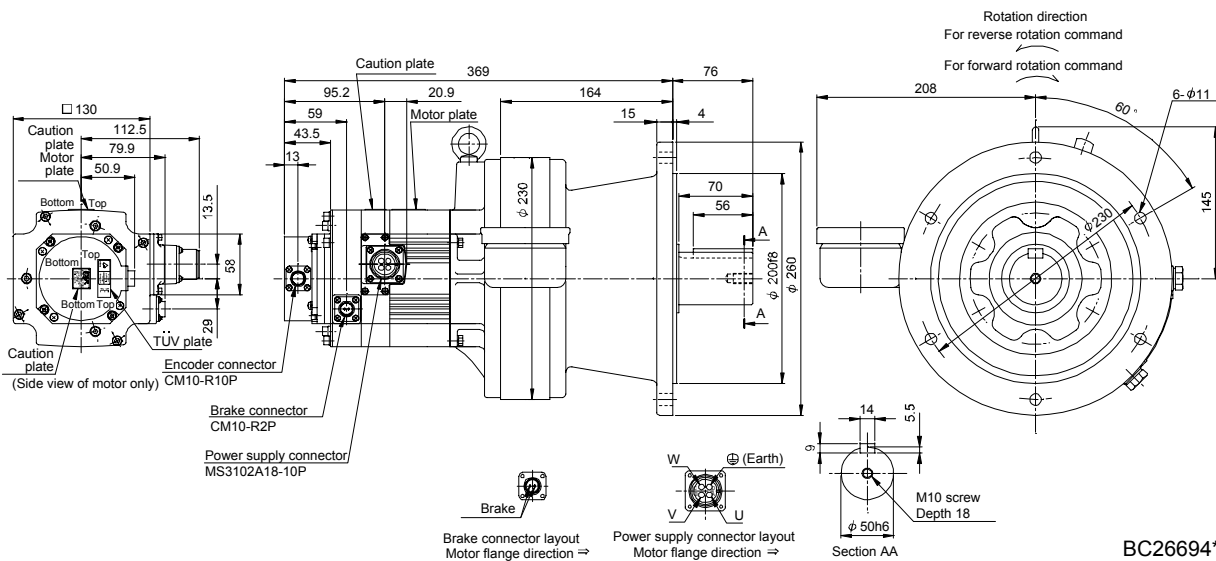

# 7. HF-SP SERIES

Model	Output [kW]	Reduction gear frame number	Reduction ratio (Actual reduction ratio)	Brake static friction torque [N · m] ([oz · in])	Inertia moment J [ $\times 10^{-4}$ kg · m <sup>2</sup> ] (WK <sup>2</sup> [oz · in <sup>2</sup> ])	Mass [kg] ([lb])
HF-SP102BG1 HF-SP1024BG1	1.0	6160	1/59	8.5 (1200)	22.4 (122)	84.5 (186)

[Unit: mm]

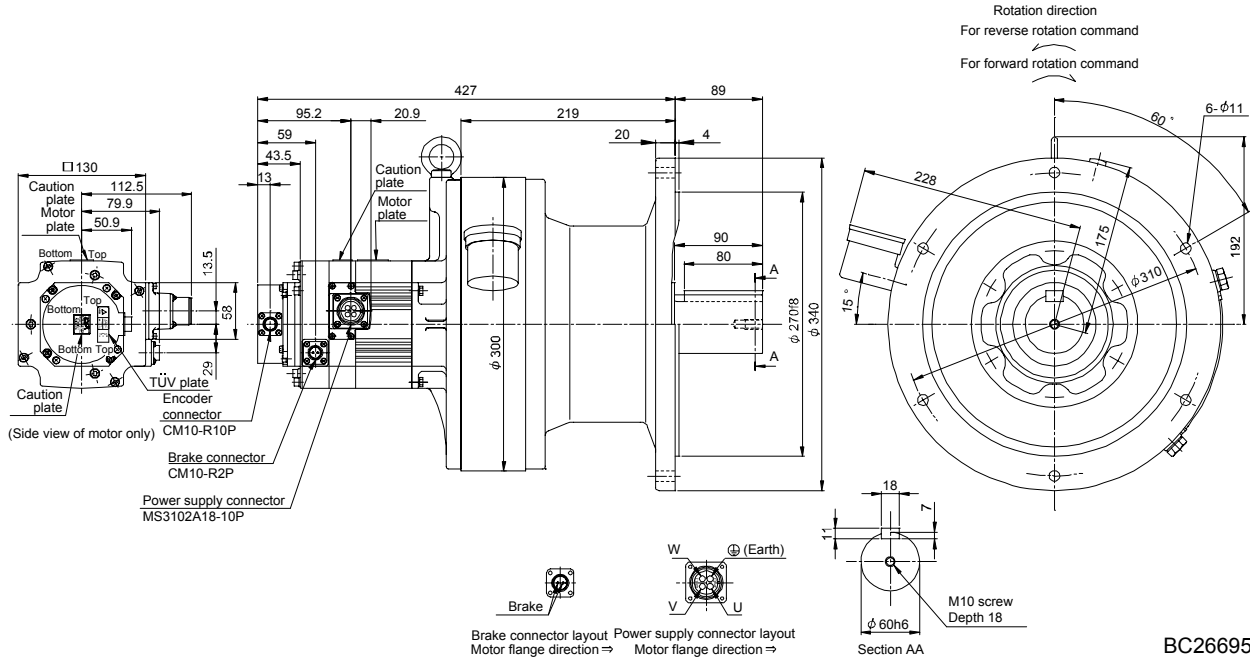

Model	Output [kW]	Reduction gear frame number	Reduction ratio (Actual reduction ratio)	Brake static friction torque [N · m] ([oz · in])	Inertia moment J [ $\times 10^{-4}$ kg · m <sup>2</sup> ] (WK <sup>2</sup> [oz · in <sup>2</sup> ])	Mass [kg] ([lb])
HF-SP152BG1 HF-SP1524BG1	1.5	6120	1/6	8.5 (1200)	23.4 (128)	32.3 (71.2)
			1/11		21.9 (120)	
			1/17		21.6 (118)	

[Unit: mm]

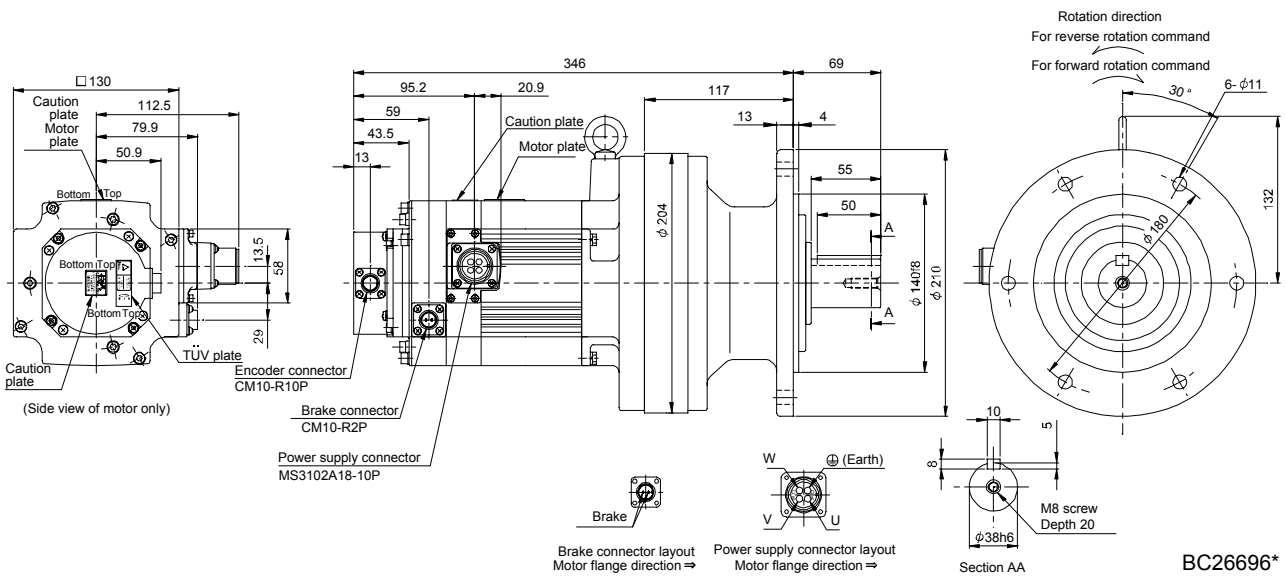

# 7. HF-SP SERIES

Model	Output [kW]	Reduction gear frame number	Reduction ratio (Actual reduction ratio)	Brake static friction torque [N · m] ([oz · in])	Inertia moment $J$ [ $\times 10^{-4} \text{kg} \cdot \text{m}^2$ ] ( $\text{WK}^2$ [oz · in <sup>2</sup> ])	Mass [kg] ([lb])
HF-SP152BG1	1.5	6130	1/29	8.5 (1200)	22.6 (124)	51.3 (113)
HF-SP1524BG1			1/35		22.5 (123)	

[Unit: mm]

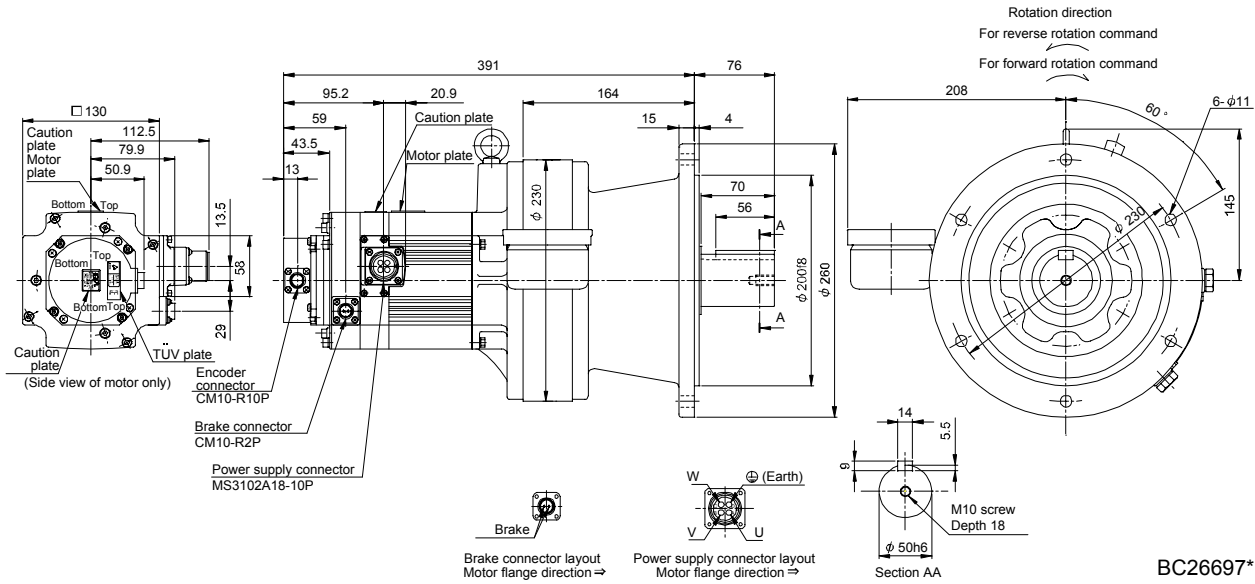

BC26697\*

Model	Output [kW]	Reduction gear frame number	Reduction ratio (Actual reduction ratio)	Brake static friction torque [N · m] ([oz · in])	Inertia moment $J$ [ $\times 10^{-4} \text{kg} \cdot \text{m}^2$ ] ( $\text{WK}^2$ [oz · in <sup>2</sup> ])	Mass [kg] ([lb])
HF-SP152BG1	1.5	6160	1/43	8.5 (1200)	28.4 (155)	86.3 (190)
HF-SP1524BG1			1/59		28.3 (155)	

[Unit: mm]

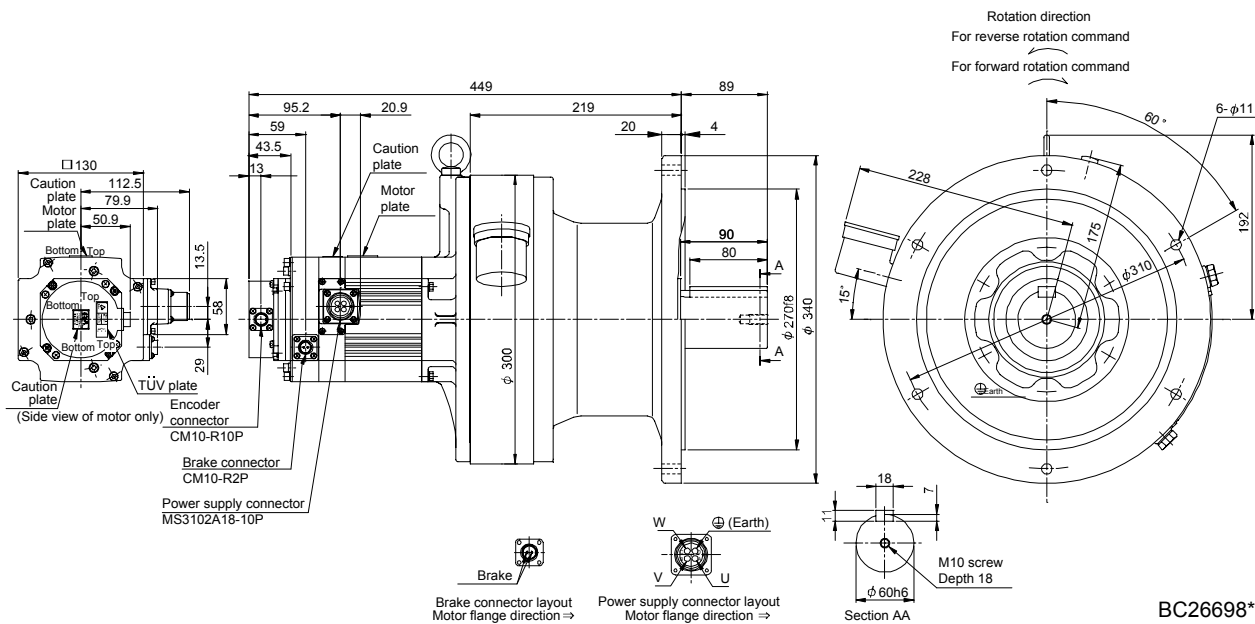

BC26698\*

# 7. HF-SP SERIES

Model	Output [kW]	Reduction gear frame number	Reduction ratio (Actual reduction ratio)	Brake static friction torque [N · m] ([oz · in])	Inertia moment $J [\times 10^{-4} \text{kg} \cdot \text{m}^2] (\text{WK}^2 [\text{oz} \cdot \text{in}^2])$	Mass [kg] ([lb])
HF-SP202BG1 HF-SP2024BG1	2.0	6120	1/6	44 (6230)	51.7 (283)	40 (88.2)
			1/11		50.2 (275)	
			1/17		49.8 (272)	

[Unit: mm]

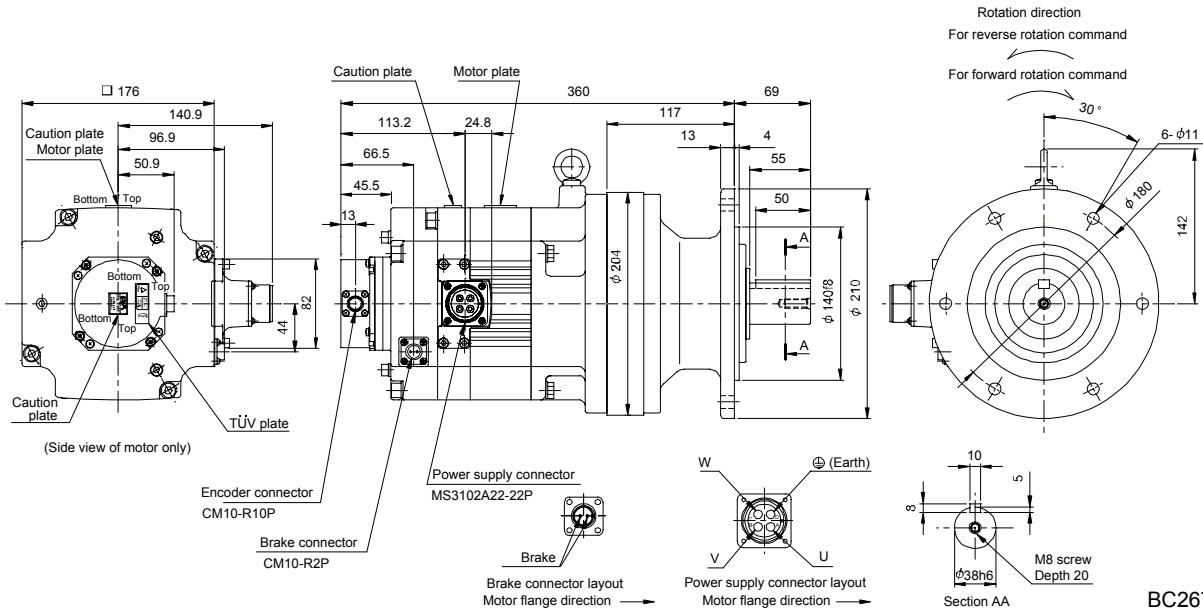

BC26715\*

Model	Output [kW]	Reduction gear frame number	Reduction ratio (Actual reduction ratio)	Brake static friction torque [N · m] ([oz · in])	Inertia moment $J [\times 10^{-4} \text{kg} \cdot \text{m}^2] (\text{WK}^2 [\text{oz} \cdot \text{in}^2])$	Mass [kg] ([lb])
HF-SP202BG1 HF-SP2024BG1	2.0	6165	1/29	44 (6230)	56.6 (310)	90 (198)
			1/35		56.4 (308)	
			1/43		56.1 (307)	
			1/59		56.0 (306)	

[Unit: mm]

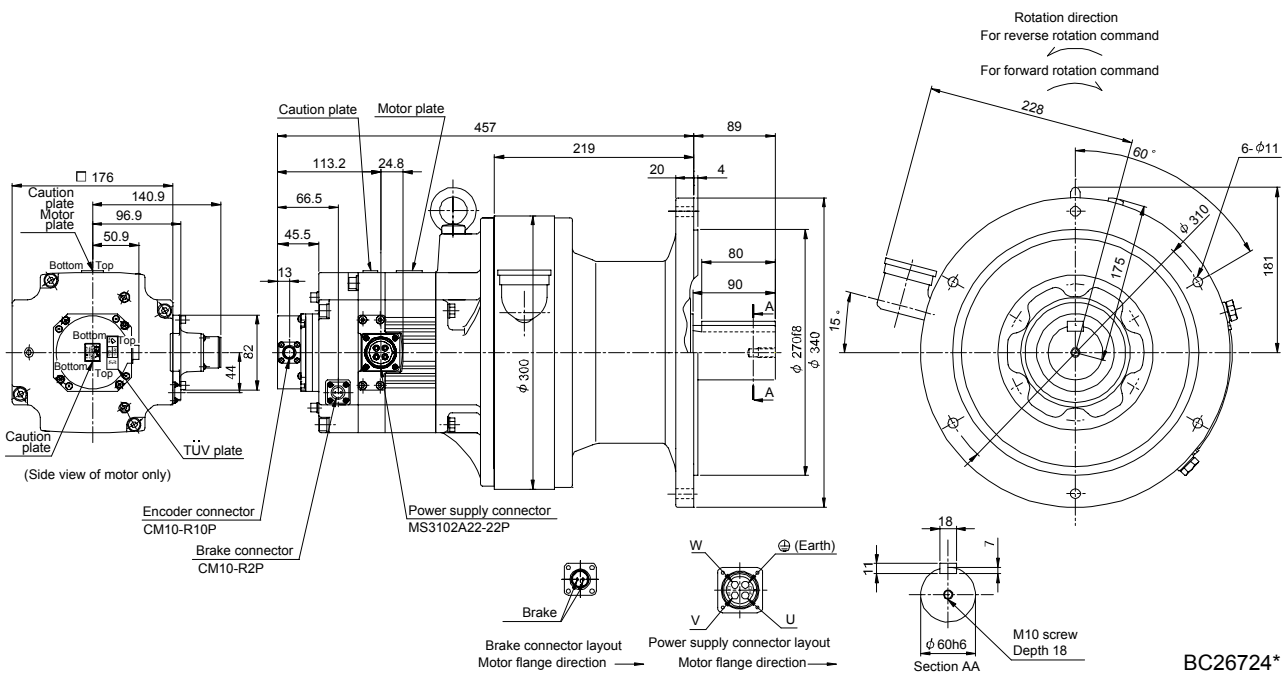

BC26724\*

# 7. HF-SP SERIES

Model	Output [kW]	Reduction gear frame number	Reduction ratio (Actual reduction ratio)	Brake static friction torque [N · m] ([oz · in])	Inertia moment J [ $\times 10^{-4}$ kg · m <sup>2</sup> ] (WK <sup>2</sup> [oz · in <sup>2</sup> ])	Mass [kg] ([lb])
HF-SP352BG1	3.5	6135	6135	44 (6230)	94.0 (514)	63 (139)
1/11			89.8 (491)			
1/17			88.5 (484)			

[Unit: mm]

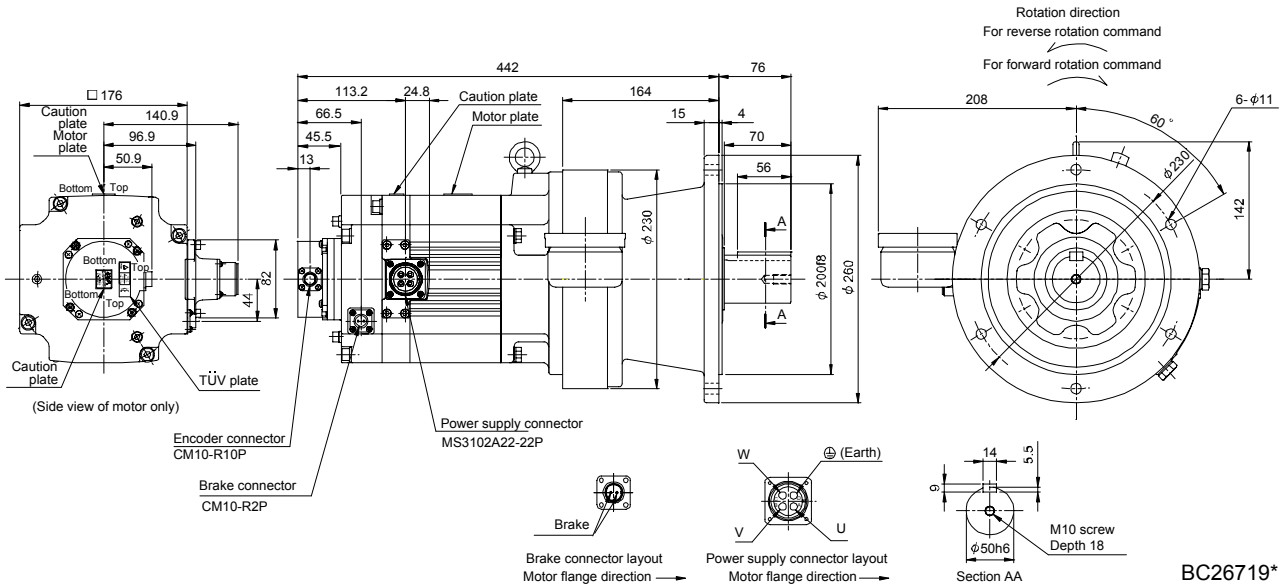

BC26719\*

Model	Output [kW]	Reduction gear frame number	Reduction ratio (Actual reduction ratio)	Brake static friction torque [N · m] ([oz · in])	Inertia moment J [ $\times 10^{-4}$ kg · m <sup>2</sup> ] (WK <sup>2</sup> [oz · in <sup>2</sup> ])	Mass [kg] ([lb])
HF-SP352BG1	3.5	6165	1/29	44 (6230)	93.6 (512)	97 (214)
HF-SP3524BG1			1/35		93.3 (510)	

[Unit: mm]

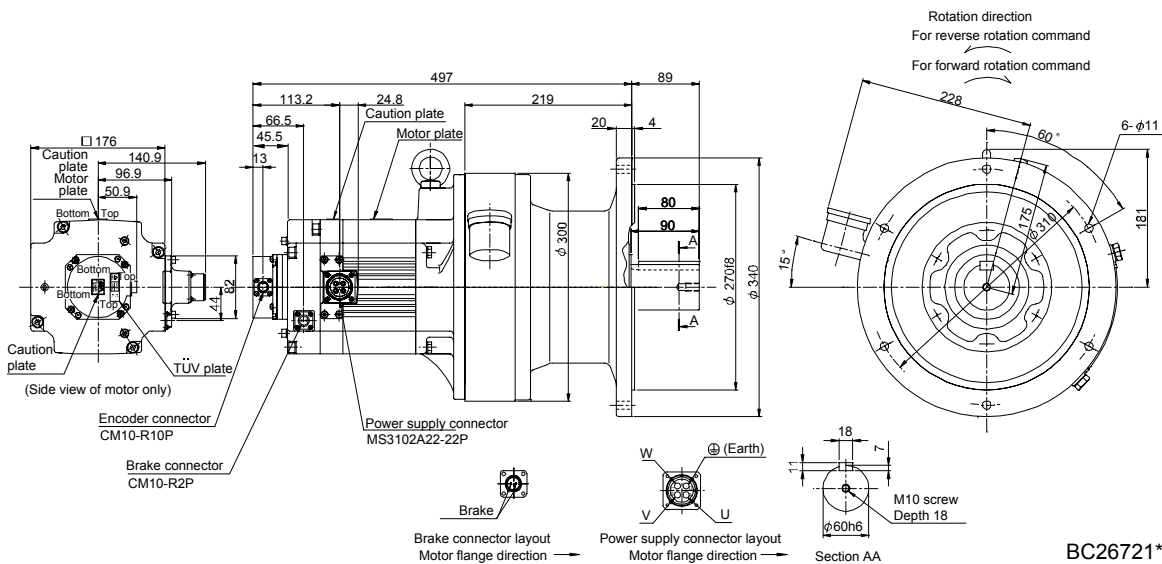

BC26721\*



## 7. HF-SP SERIES

Model	Output [kW]	Reduction gear frame number	Reduction ratio (Actual reduction ratio)	Brake static friction torque [N · m] ([oz · in])	Inertia moment $J [\times 10^{-4} \text{kg} \cdot \text{m}^2] (\text{WK}^2 [\text{oz} \cdot \text{in}^2])$	Mass [kg] ([lb])
HF-SP352BG1	3.5	6175	1/43	44 (6230)	111.5 (610)	139 (306)
HF-SP3524BG1			1/59		110.9 (606)	

[Unit: mm]

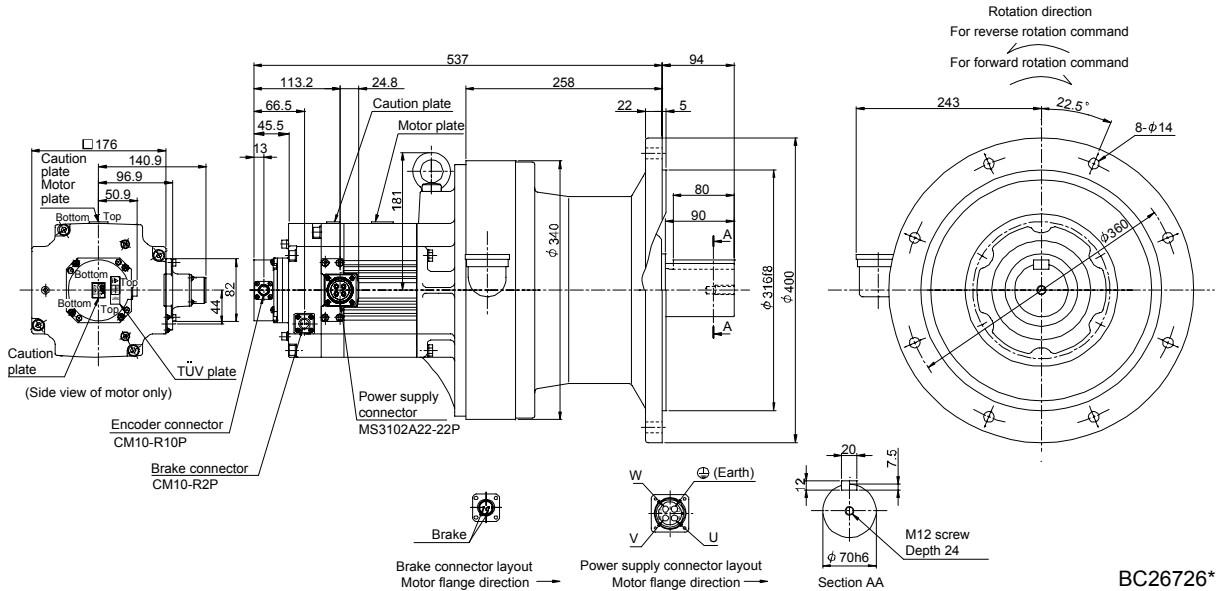

Model	Output [kW]	Reduction gear frame number	Reduction ratio (Actual reduction ratio)	Brake static friction torque [N · m] ([oz · in])	Inertia moment $J [\times 10^{-4} \text{kg} \cdot \text{m}^2] (\text{WK}^2 [\text{oz} \cdot \text{in}^2])$	Mass [kg] ([lb])
HF-SP502BG1	5.0	6165	1/6	44(6230)	130.8 (715)	101 (223)
HF-SP5024BG1			1/11		118.5 (648)	
			1/17		114.5 (626)	

[Unit: mm]

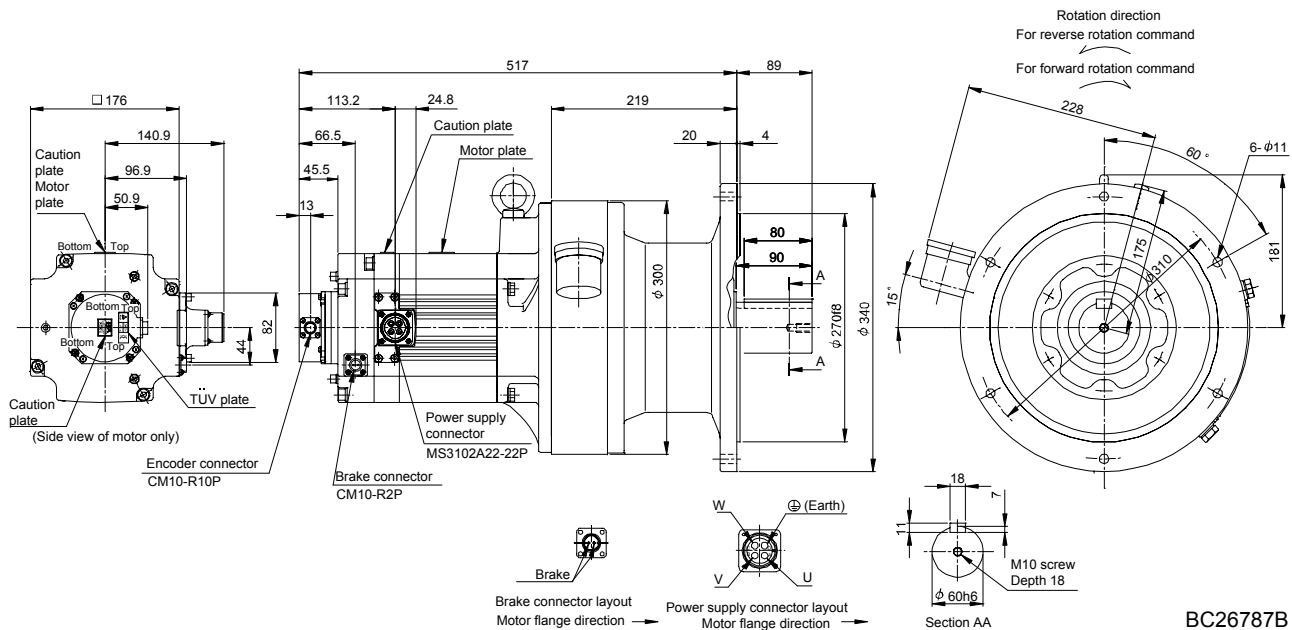

## 7. HF-SP SERIES

Model	Output [kW]	Reduction gear frame number	Reduction ratio (Actual reduction ratio)	Brake static friction torque [N · m] ([oz · in])	Inertia moment $J$ [ $\times 10^{-4}$ kg · m <sup>2</sup> ] (WK <sup>2</sup> [oz · in <sup>2</sup> ])	Mass [kg] ([lb])
HF-SP502BG1	5.0	6180	1/29	44 (6230)	145.3 (794)	168 (370)
1/35			144.8 (792)			
1/43			143.8 (786)			

[Unit: mm]

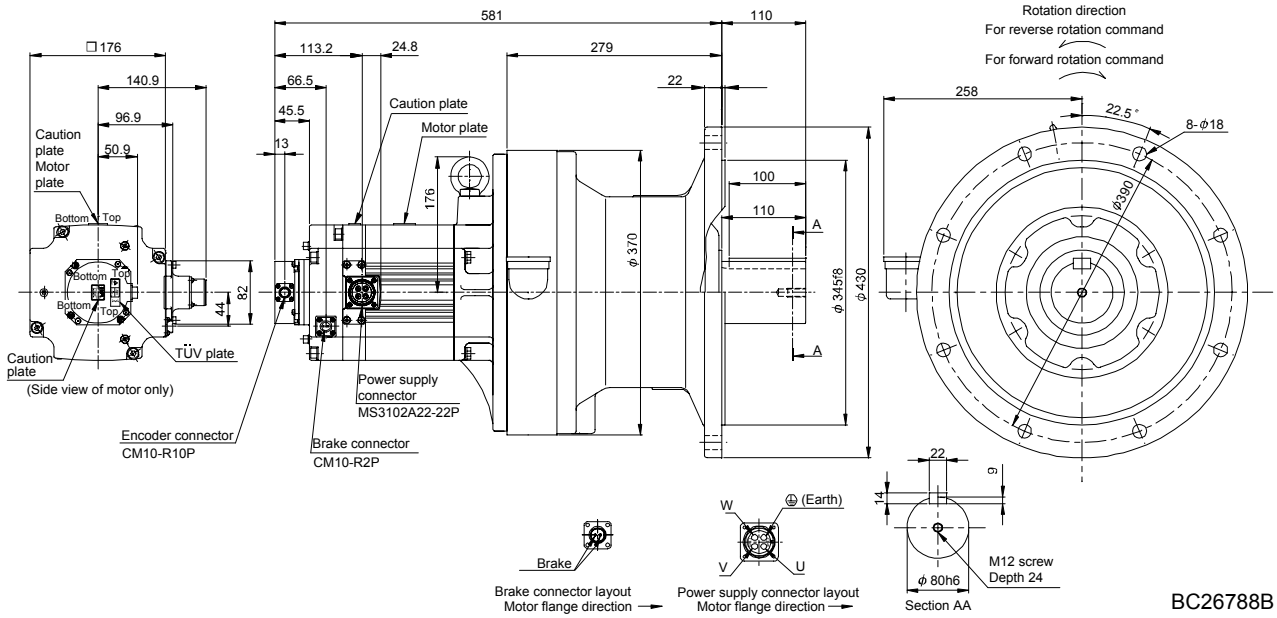

BC26788B

Model	Output [kW]	Reduction gear frame number	Reduction ratio (Actual reduction ratio)	Brake static friction torque [N · m] ([oz · in])	Inertia moment $J$ [ $\times 10^{-4}$ kg · m <sup>2</sup> ] (WK <sup>2</sup> [oz · in <sup>2</sup> ])	Mass [kg] ([lb])
HF-SP502BG1	5.0	6185	1/59	44 (6230)	142.6 (780)	168 (370)
HF-SP5024BG1						

[Unit: mm]

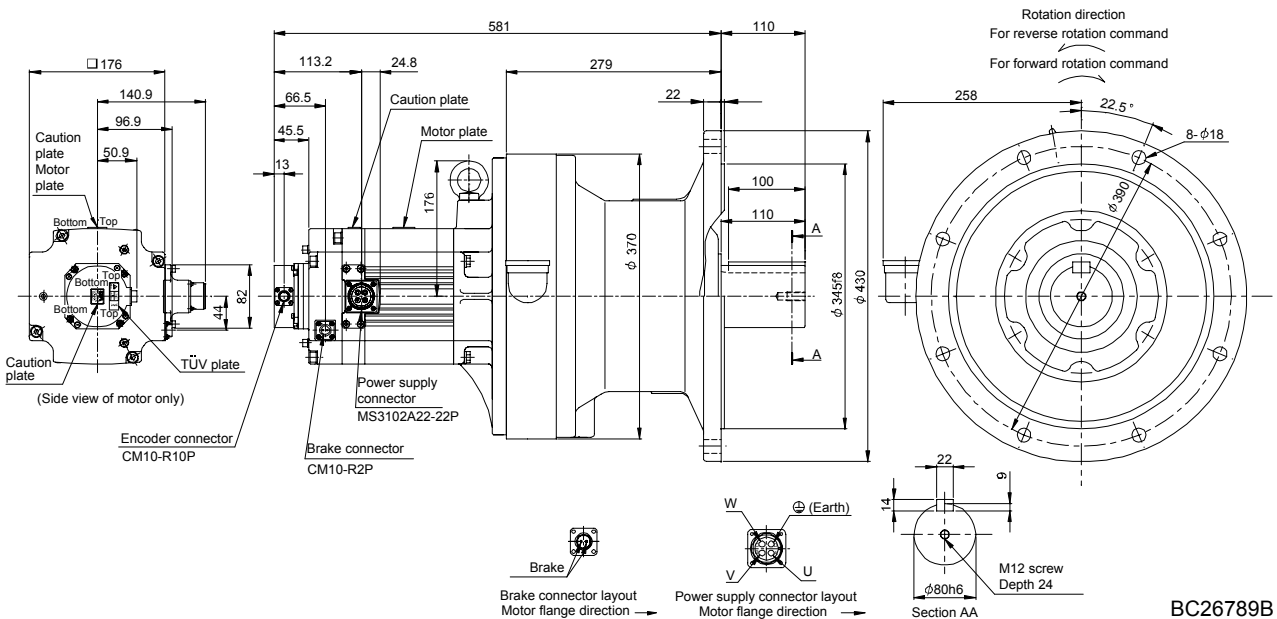

BC26789B

# 7. HF-SP SERIES

Model	Output [kW]	Reduction gear frame number	Reduction ratio (Actual reduction ratio)	Brake static friction torque [N · m] ([oz · in])	Inertia moment $J$ [ $\times 10^{-4}$ kg · m <sup>2</sup> ] ( $WK^2$ [oz · in <sup>2</sup> ])	Mass [kg] ([lb])
HF-SP702BG1 HF-SP7024BG1	7.0	6165	1/6	44 (6230)	187.0 (1020)	110 (243)

[Unit: mm]

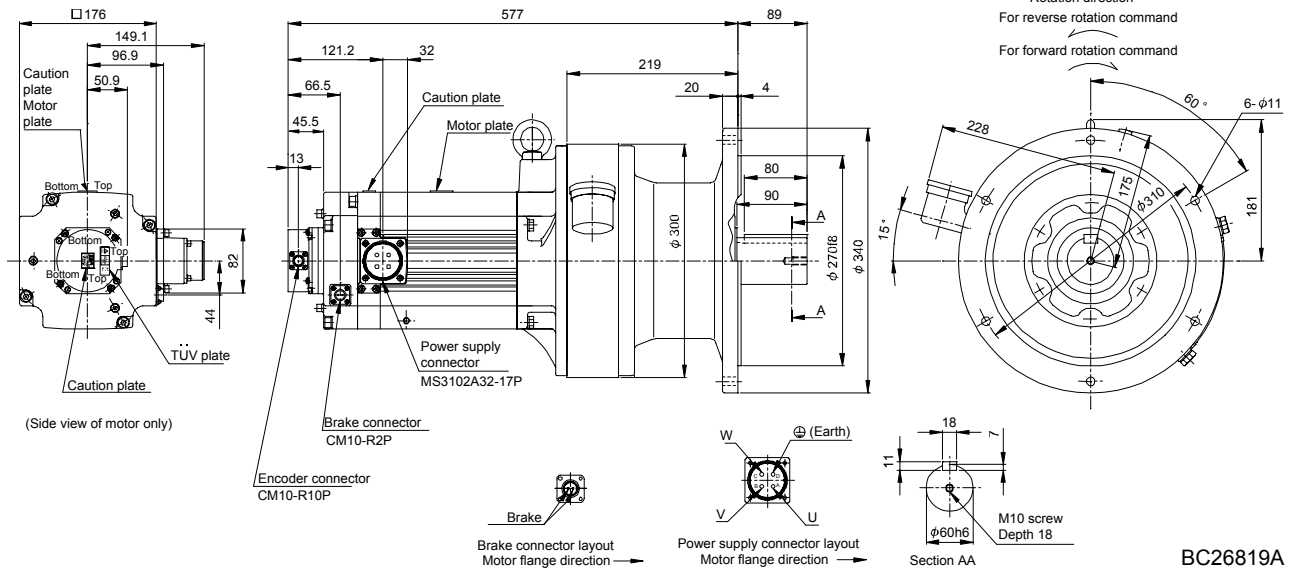

BC26819A

Model	Output [kW]	Reduction gear frame number	Reduction ratio (Actual reduction ratio)	Brake static friction torque [N · m] ([oz · in])	Inertia moment $J$ [ $\times 10^{-4}$ kg · m <sup>2</sup> ] ( $WK^2$ [oz · in <sup>2</sup> ])	Mass [kg] ([lb])
HF-SP702BG1 HF-SP7024BG1	7.0	6170	1/11	44 (6230)	199.9 (1090)	152 (335)
			1/17		192.4 (1050)	

[Unit: mm]

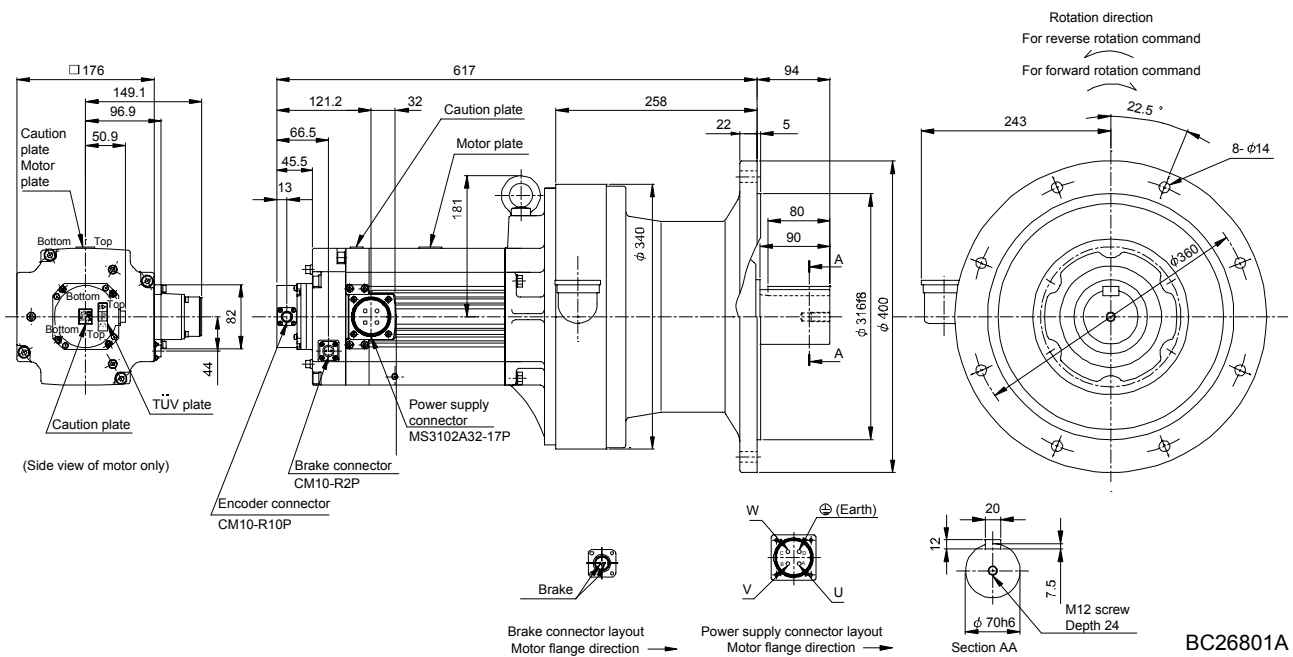

BC26801A

# 7. HF-SP SERIES

Model	Output [kW]	Reduction gear frame number	Reduction ratio (Actual reduction ratio)	Brake static friction torque [N · m] ([oz · in])	Inertia moment J [ $\times 10^{-4}$ kg · m <sup>2</sup> ] (WK <sup>2</sup> [oz · in <sup>2</sup> ])	Mass [kg] ([lb])
HF-SP702BG1	7.0	6180	1/29	44 (6230)	202.0 (1100)	177 (390)
HF-SP7024BG1			1/35		201.5 (1100)	

[Unit: mm]

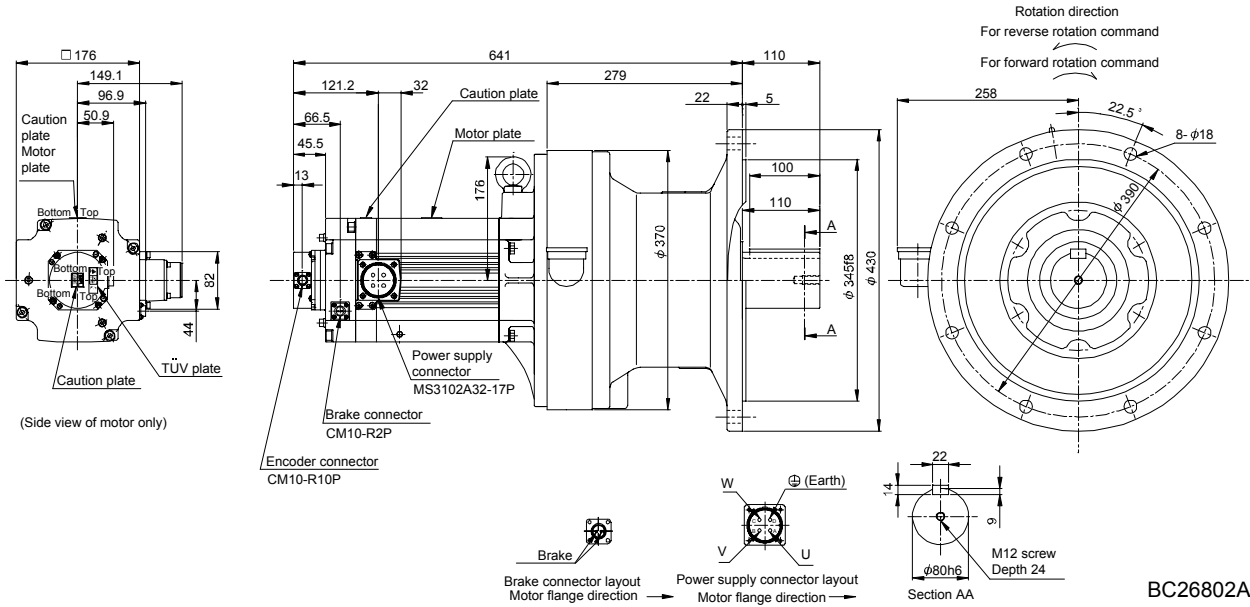

BC26802A

Model	Output [kW]	Reduction gear frame number	Reduction ratio (Actual reduction ratio)	Brake static friction torque [N · m] ([oz · in])	Inertia moment J [ $\times 10^{-4}$ kg · m <sup>2</sup> ] (WK <sup>2</sup> [oz · in <sup>2</sup> ])	Mass [kg] ([lb])
HF-SP702BG1	7.0	6195	1/43	44 (6230)	278.3 (1520)	246 (542)
HF-SP7024BG1			1/59		276.5 (1510)	

[Unit: mm]

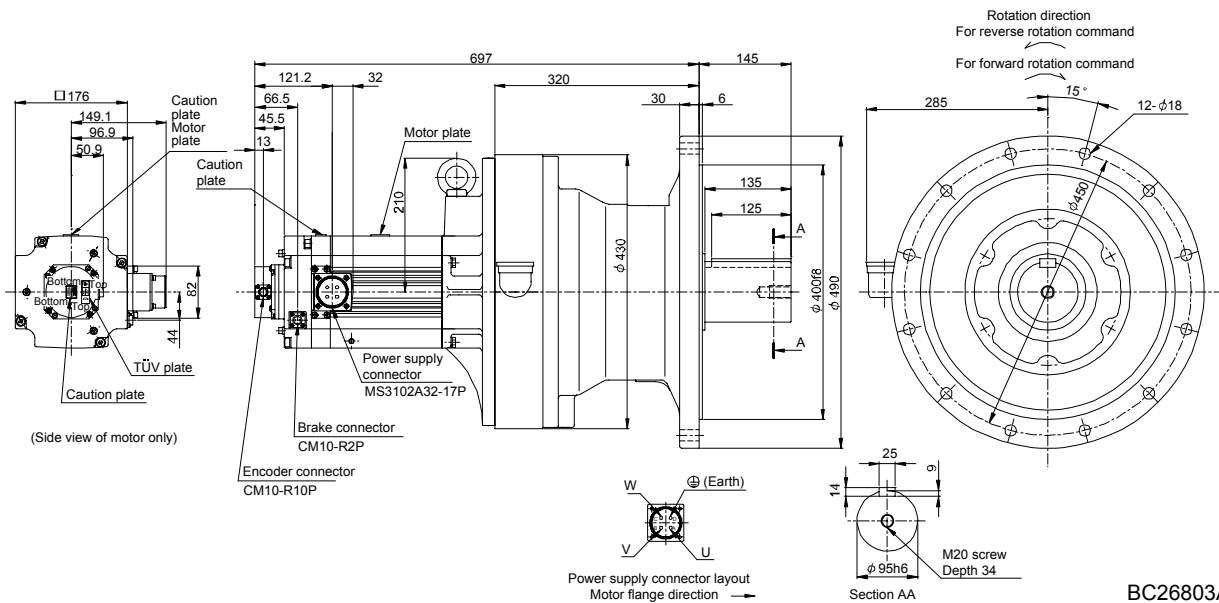

BC26803A

## 7. HF-SP SERIES

### 7.8.5 For general industrial machine with a reduction gear (leg type · without an electromagnetic brake)

Model	Output [kW]	Reduction gear frame number	Reduction ratio (Actual reduction ratio)	Inertia moment $J [\times 10^{-4} \text{kg} \cdot \text{m}^2]$ ( $\text{WK}^2 [\text{oz} \cdot \text{in}^2]$ )	Mass [kg] (lb)
HF-SP52G1H HF-SP524G1H	0.5	6100	1/6	7.10 (38.8)	20.8 (45.9)
			1/11	6.70 (36.6)	
			1/17	6.60 (36.1)	
			1/29	6.50 (35.5)	

[Unit: mm]

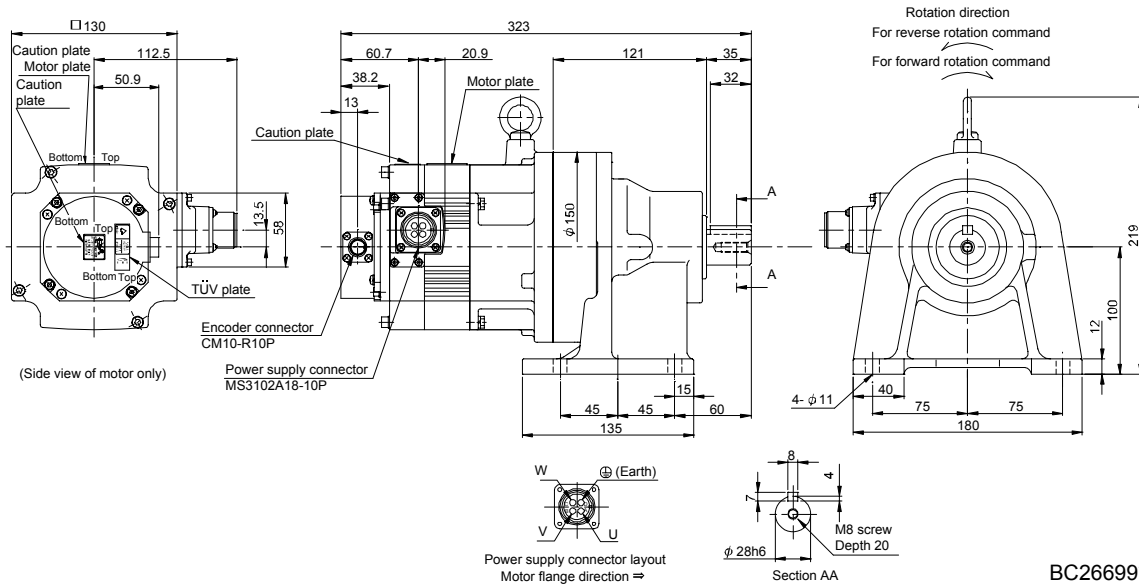

Model	Output [kW]	Reduction gear frame number	Reduction ratio (Actual reduction ratio)	Inertia moment $J [\times 10^{-4} \text{kg} \cdot \text{m}^2]$ ( $\text{WK}^2 [\text{oz} \cdot \text{in}^2]$ )	Mass [kg] (lb)
HF-SP52G1H HF-SP524G1H	0.5	6120	1/35	7.30 (39.9)	27.8 (61.3)
			1/43		
			1/59	7.20 (39.4)	

[Unit: mm]

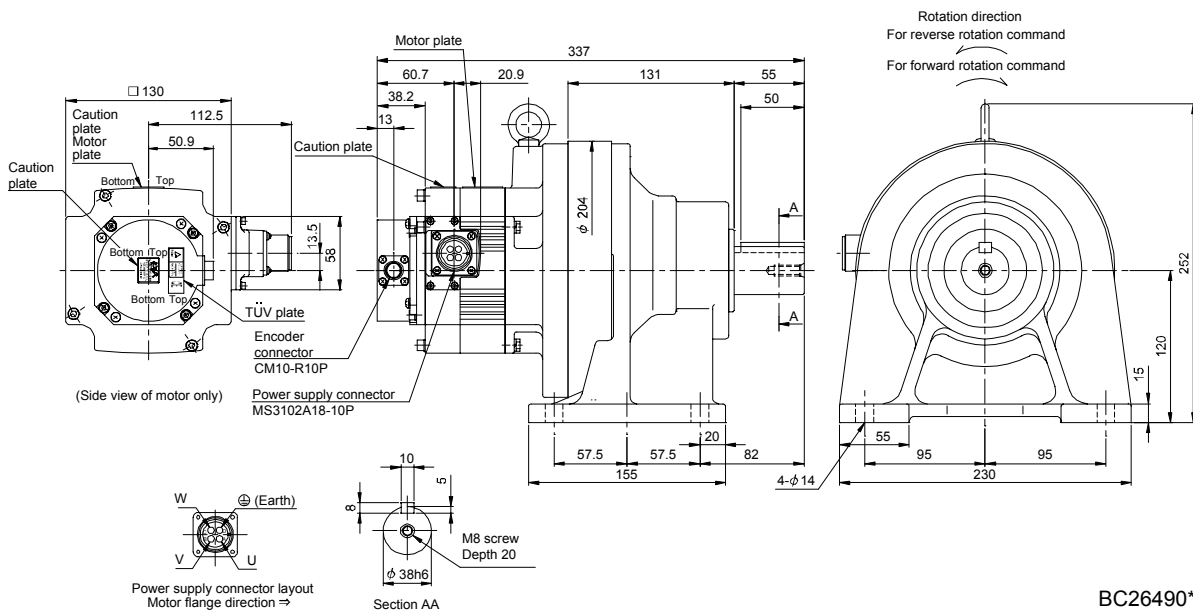

# 7. HF-SP SERIES

Model	Output [kW]	Reduction gear frame number	Reduction ratio (Actual reduction ratio)	Inertia moment $J [\times 10^{-4} \text{kg} \cdot \text{m}^2] (\text{WK}^2 [\text{oz} \cdot \text{in}^2])$	Mass [kg] (lb)
HF-SP102G1H HF-SP1024G1H	1.0	6120	1/6	15.4 (84.2)	29.5 (65.0)
			1/11	13.9 (76.0)	
			1/17	13.5 (73.8)	
			1/29	13.2 (72.2)	
			1/35		

[Unit: mm]

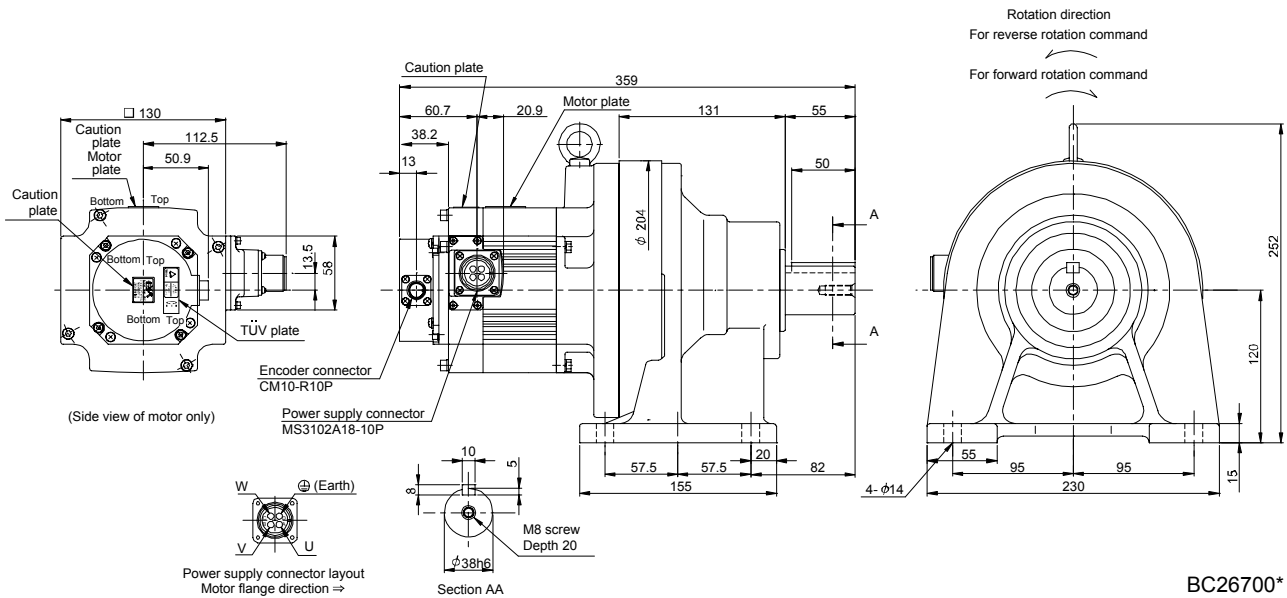

Model	Output [kW]	Reduction gear frame number	Reduction ratio (Actual reduction ratio)	Inertia moment $J [\times 10^{-4} \text{kg} \cdot \text{m}^2] (\text{WK}^2 [\text{oz} \cdot \text{in}^2])$	Mass [kg] (lb)
HF-SP102G1H HF-SP1024G1H	1.0	6130	1/43	14.3 (78.2)	50.5 (111)

[Unit: mm]

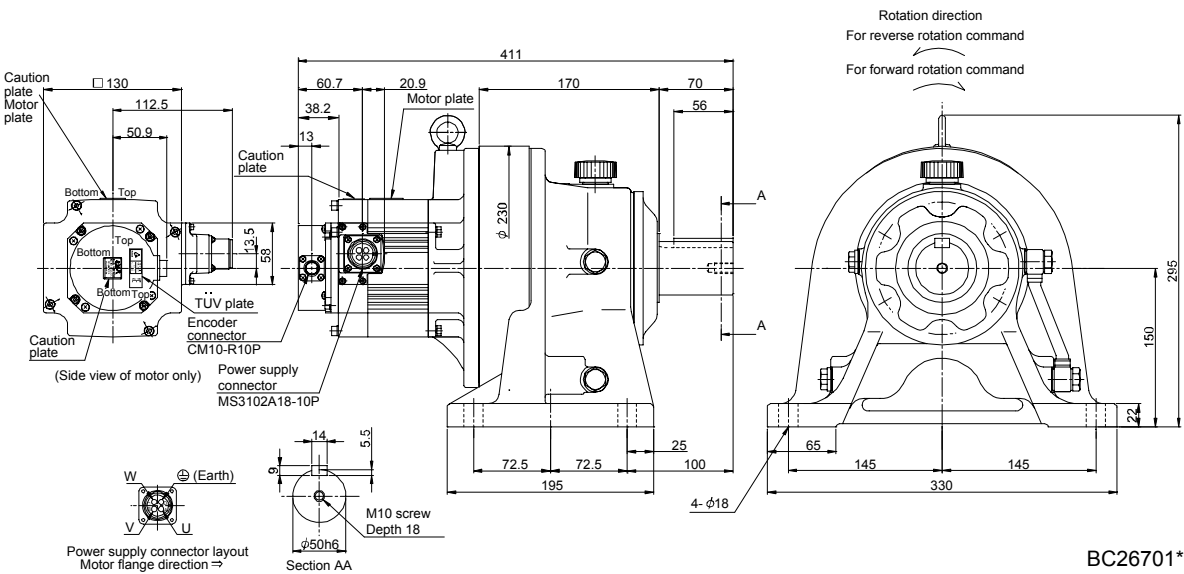

# 7. HF-SP SERIES

Model	Output [kW]	Reduction gear frame number	Reduction ratio (Actual reduction ratio)	Inertia moment $J [\times 10^{-4} \text{kg} \cdot \text{m}^2] (\text{WK}^2 [\text{oz} \cdot \text{in}^2])$	Mass [kg] (lb)
HF-SP102G1H HF-SP1024G1H	1.0	6160	1/59	20.3 (111)	89.5 (197)

[Unit: mm]

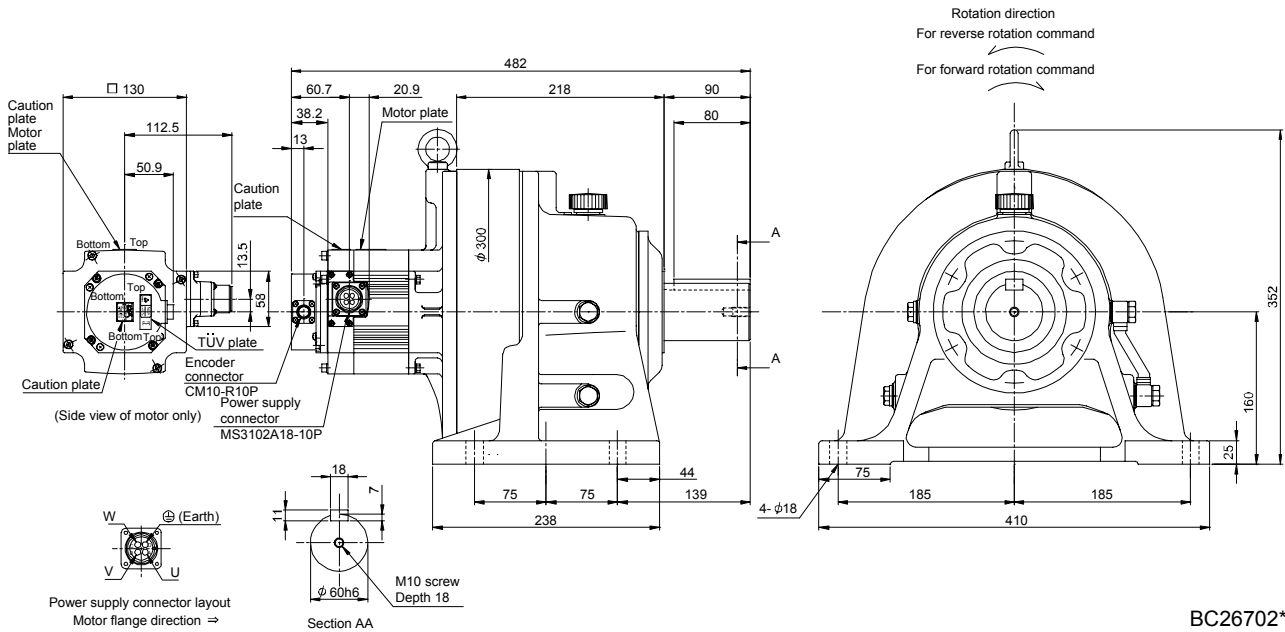

Model	Output [kW]	Reduction gear frame number	Reduction ratio (Actual reduction ratio)	Inertia moment $J [\times 10^{-4} \text{kg} \cdot \text{m}^2] (\text{WK}^2 [\text{oz} \cdot \text{in}^2])$	Mass [kg] (lb)
HF-SP152G1H HF-SP1524G1H	1.5	6120	1/6	21.3 (116)	31.3 (69.0)
			1/11	19.8 (108)	
			1/17	19.4 (106)	

[Unit: mm]

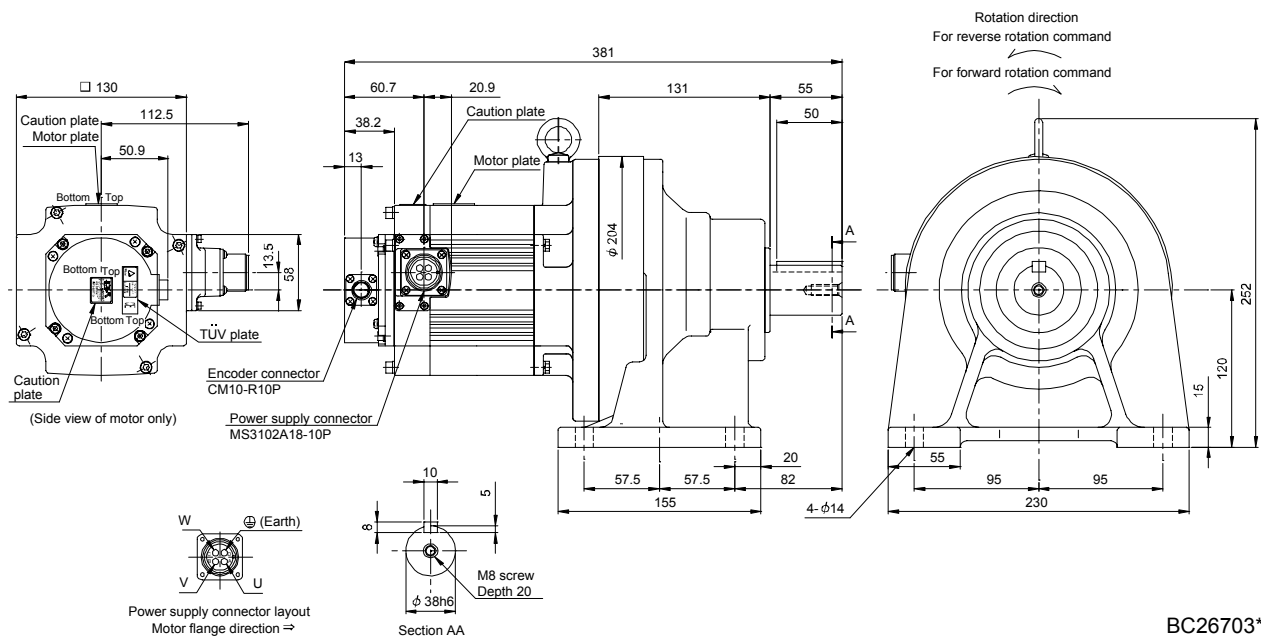

## 7. HF-SP SERIES

Model	Output [kW]	Reduction gear frame number	Reduction ratio (Actual reduction ratio)	Inertia moment $J [\times 10^{-4} \text{kg} \cdot \text{m}^2]$ ( $\text{WK}^2 [\text{oz} \cdot \text{in}^2]$ )	Mass [kg] ([lb])
HF-SP152G1H	1.5	6130	1/29	20.4 (112)	52.3 (115)
HF-SP1524G1H			1/35		

[Unit: mm]

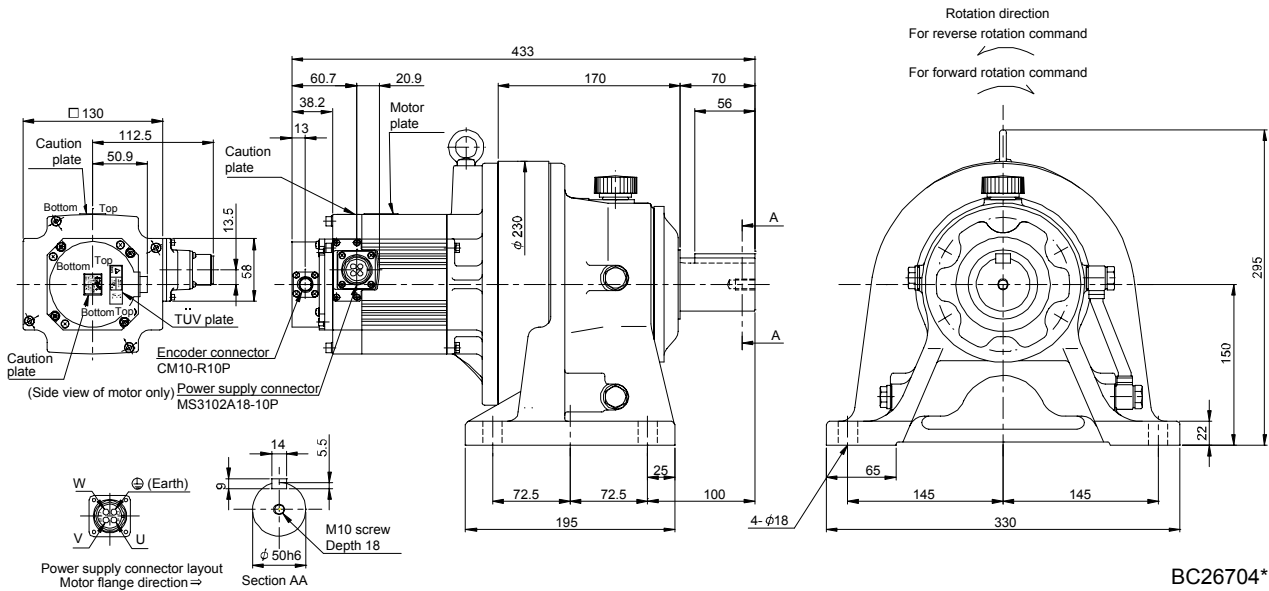

Model	Output [kW]	Reduction gear frame number	Reduction ratio (Actual reduction ratio)	Inertia moment $J [\times 10^{-4} \text{kg} \cdot \text{m}^2]$ ( $\text{WK}^2 [\text{oz} \cdot \text{in}^2]$ )	Mass [kg] ([lb])
HF-SP152G1H	1.5	6160	1/43	26.3 (144)	91.3 (201)
HF-SP1524G1H			1/59	26.2 (143)	

[Unit: mm]

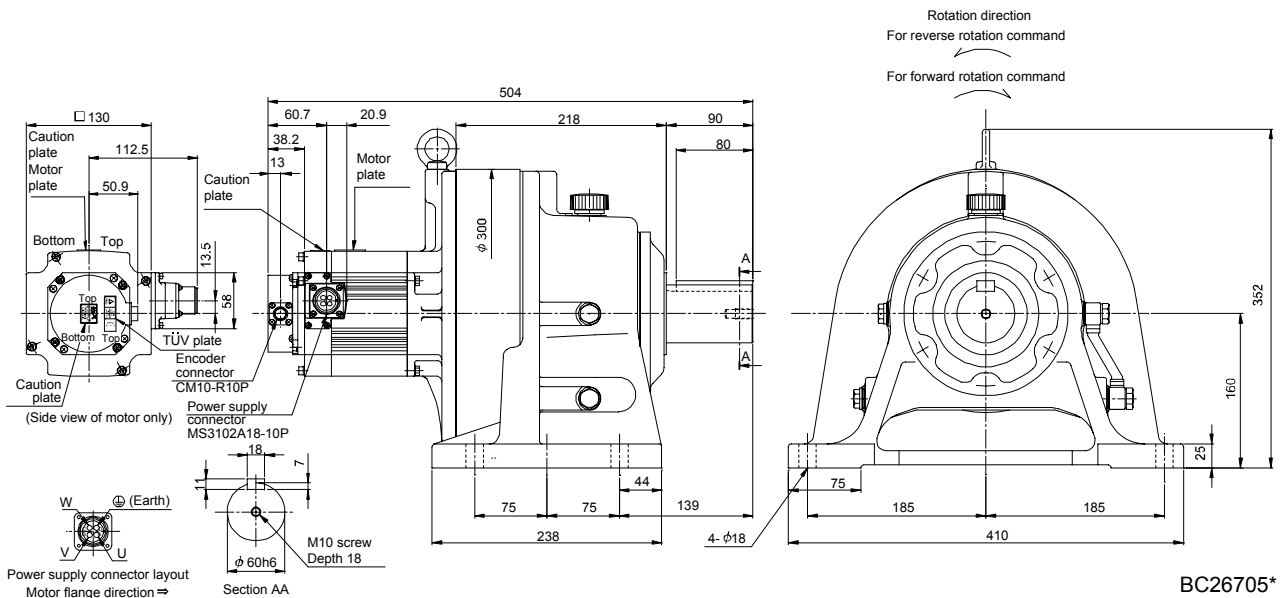



# 7. HF-SP SERIES

Model	Output [kW]	Reduction gear frame number	Reduction ratio (Actual reduction ratio)	Inertia moment $J [\times 10^{-4} \text{kg} \cdot \text{m}^2] (\text{WK}^2 [\text{oz} \cdot \text{in}^2])$	Mass [kg] ([lb])
HF-SP202G1H HF-SP2024G1H	2.0	6120	1/6	42.1 (230)	35 (77.2)
			1/11	40.5 (221)	
			1/17	40.2 (220)	

[Unit: mm]

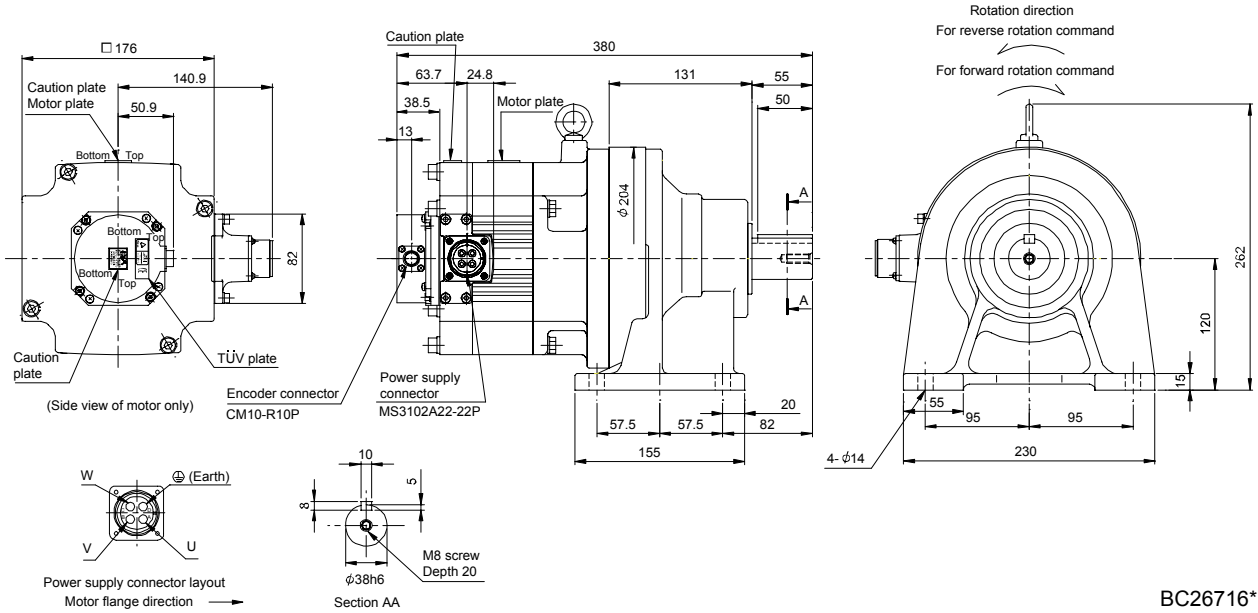

BC26716\*

Model	Output [kW]	Reduction gear frame number	Reduction ratio (Actual reduction ratio)	Inertia moment $J [\times 10^{-4} \text{kg} \cdot \text{m}^2] (\text{WK}^2 [\text{oz} \cdot \text{in}^2])$	Mass [kg] ([lb])
HF-SP202G1H HF-SP2024G1H	2.0	6165	1/29	46.9 (256)	91 (201)
			1/35	46.7 (255)	
			1/43	46.4 (254)	
			1/59	46.4 (254)	

[Unit: mm]

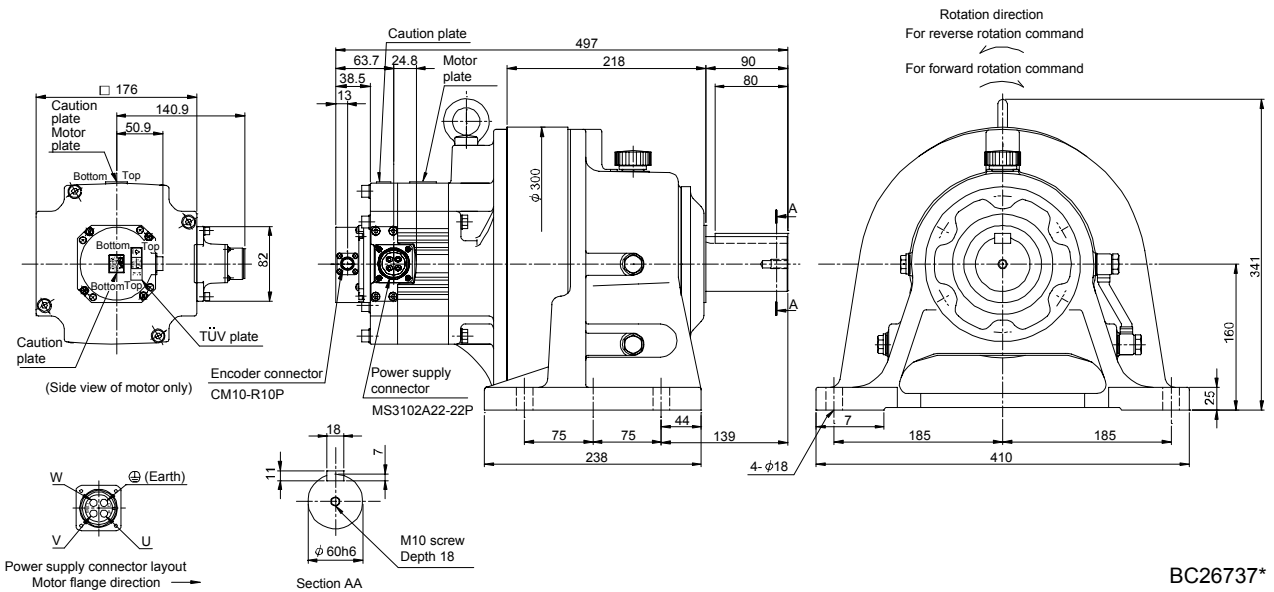

BC26737\*

# 7. HF-SP SERIES

Model	Output [kW]	Reduction gear frame number	Reduction ratio (Actual reduction ratio)	Inertia moment $J [\times 10^{-4} \text{kg} \cdot \text{m}^2]$ ( $\text{WK}^2 [\text{oz} \cdot \text{in}^2]$ )	Mass [kg] (lb)
HF-SP352G1H HF-SP3524G1H	3.5	6135	1/6	84.4 (461)	60 (132)
			1/11	80.1 (438)	
			1/17	78.8 (431)	

[Unit: mm]

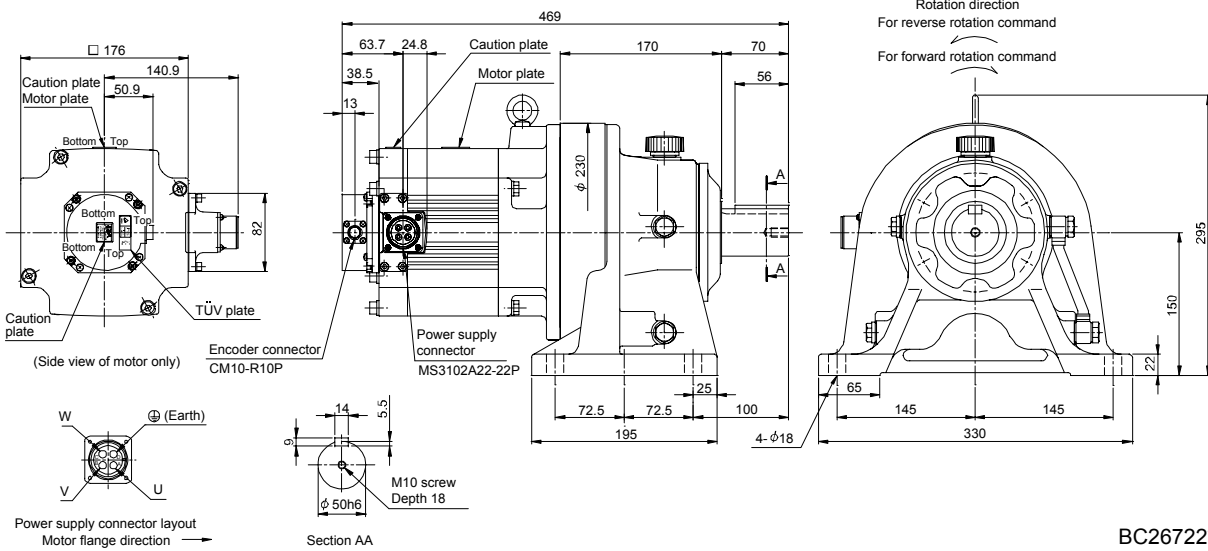

BC26722\*

Model	Output [kW]	Reduction gear frame number	Reduction ratio (Actual reduction ratio)	Inertia moment $J [\times 10^{-4} \text{kg} \cdot \text{m}^2]$ ( $\text{WK}^2 [\text{oz} \cdot \text{in}^2]$ )	Mass [kg] (lb)
HF-SP352G1H HF-SP3524G1H	3.5	6165	1/29	83.9 (459)	98 (216)
			1/35	83.7 (458)	

[Unit: mm]

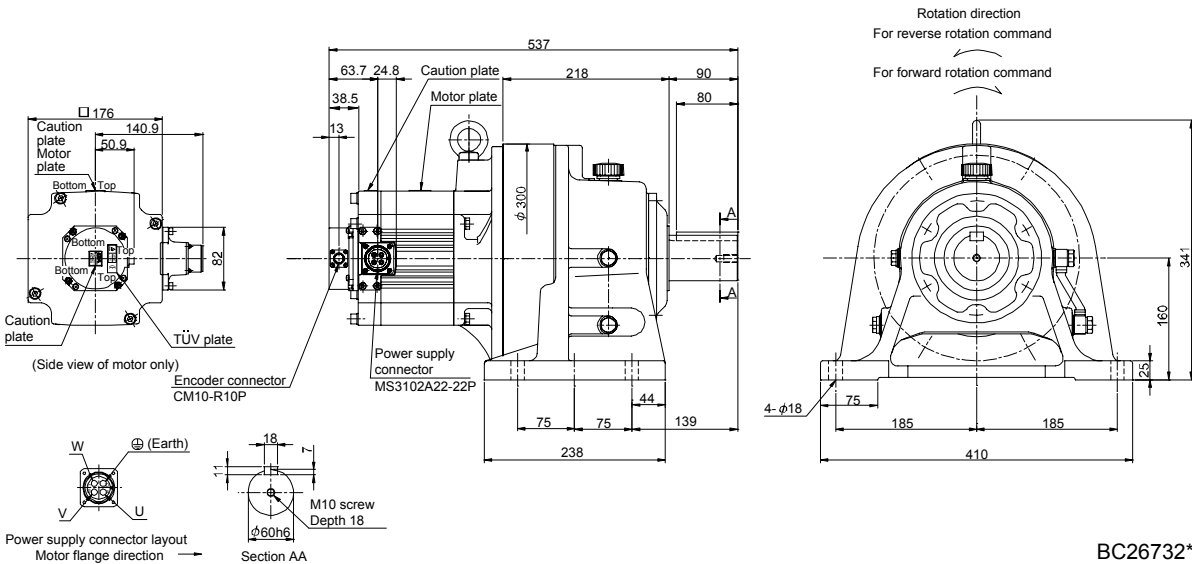

BC26732\*

# 7. HF-SP SERIES

Model	Output [kW]	Reduction gear frame number	Reduction ratio (Actual reduction ratio)	Inertia moment $J [\times 10^{-4} \text{kg} \cdot \text{m}^2] (\text{WK}^2 [\text{oz} \cdot \text{in}^2])$	Mass [kg] ([lb])
HF-SP352G1H	3.5	6175	1/43	101.9 (557)	139 (306)
HF-SP3524G1H			1/59	101.3 (554)	

[Unit: mm]

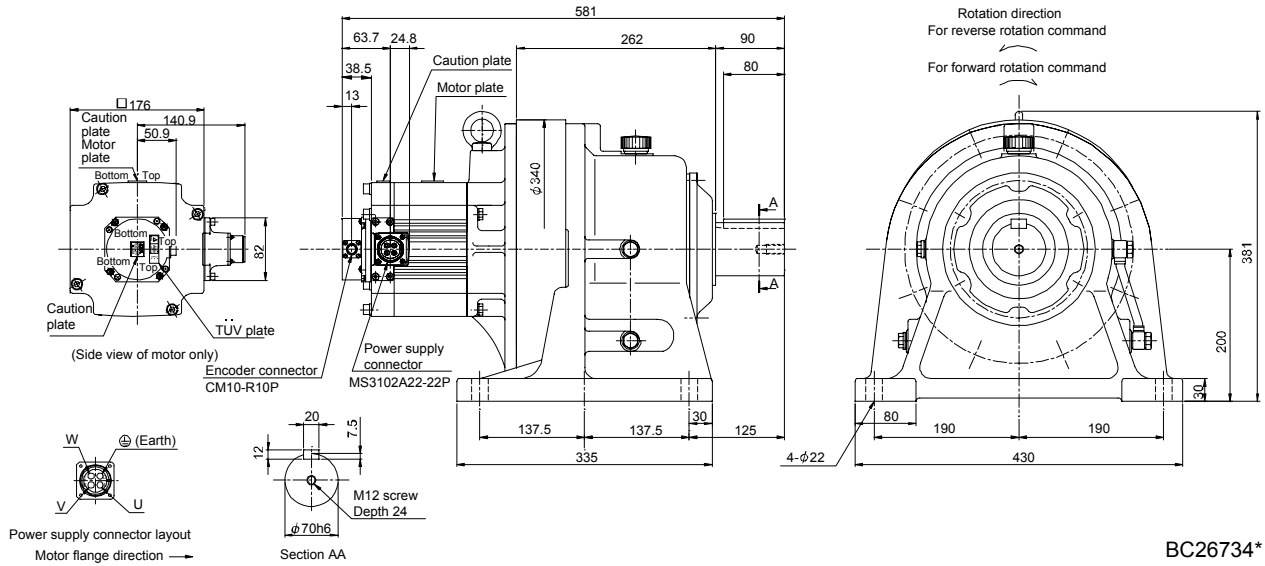

BC26734\*

Model	Output [kW]	Reduction gear frame number	Reduction ratio (Actual reduction ratio)	Inertia moment $J [\times 10^{-4} \text{kg} \cdot \text{m}^2] (\text{WK}^2 [\text{oz} \cdot \text{in}^2])$	Mass [kg] ([lb])
HF-SP502G1H	5.0	6175	1/6	121.2 (663)	102 (225)
HF-SP5024G1H			1/11	108.9 (595)	
			1/17	104.8 (573)	

[Unit: mm]

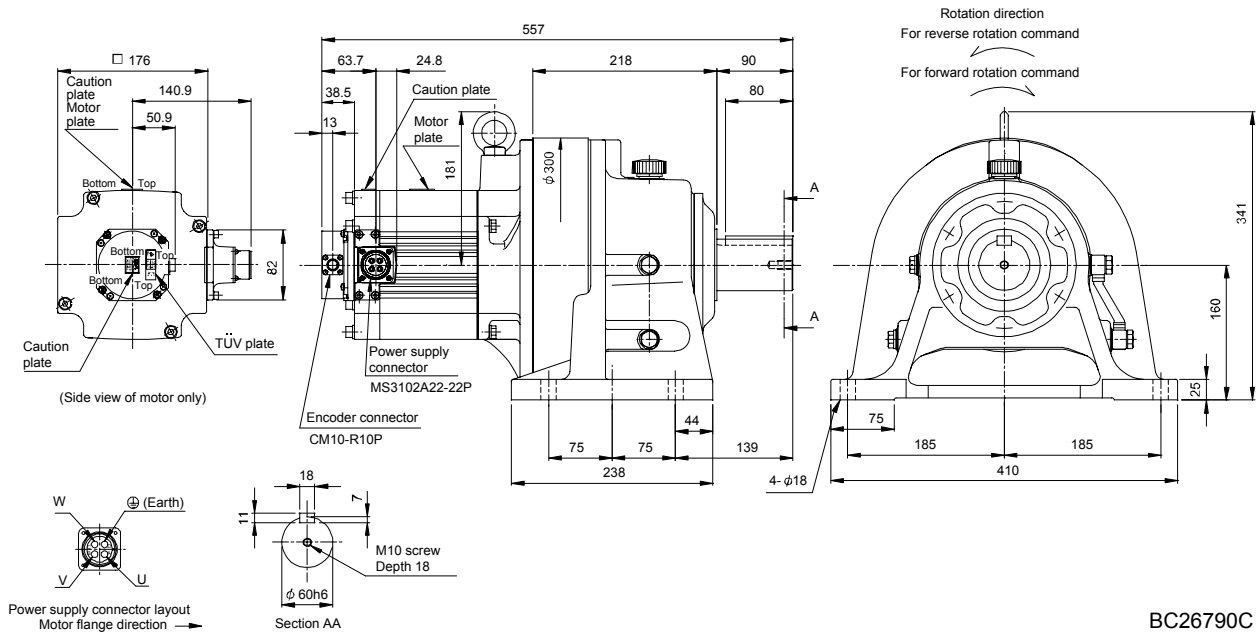

BC26790C

## 7. HF-SP SERIES

Model	Output [kW]	Reduction gear frame number	Reduction ratio (Actual reduction ratio)	Inertia moment $J [\times 10^{-4} \text{kg} \cdot \text{m}^2] (\text{WK}^2 [\text{oz} \cdot \text{in}^2])$	Mass [kg] ([lb])
HF-SP502G1H HF-SP5024G1H	5.0	6180	1/29 1/35 1/43	135.6 (741) 135.1 (739) 134.1 (733)	171 (377)

[Unit: mm]

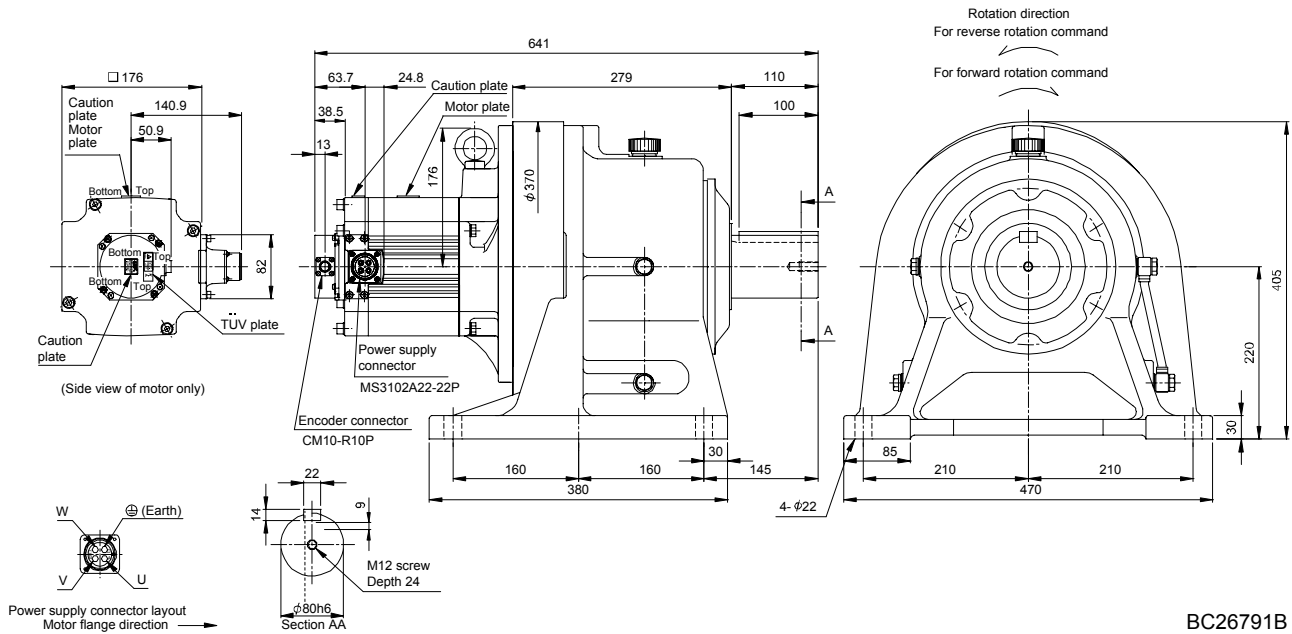

Model	Output [kW]	Reduction gear frame number	Reduction ratio (Actual reduction ratio)	Inertia moment $J [\times 10^{-4} \text{kg} \cdot \text{m}^2] (\text{WK}^2 [\text{oz} \cdot \text{in}^2])$	Mass [kg] ([lb])
HF-SP502G1H HF-SP5024G1H	5.0	6185	1/59	132.9 (727)	171 (377)

[Unit: mm]

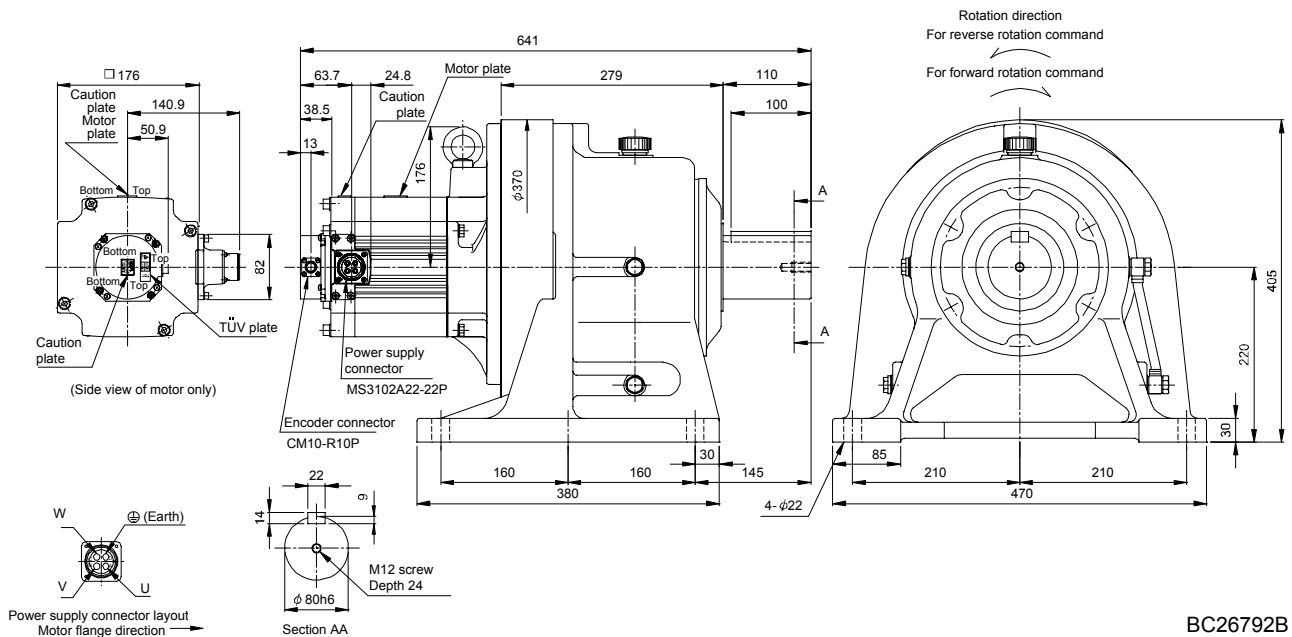

# 7. HF-SP SERIES

Model	Output [kW]	Reduction gear frame number	Reduction ratio (Actual reduction ratio)	Inertia moment $J [\times 10^{-4} \text{kg} \cdot \text{m}^2] (\text{WK}^2 [\text{oz} \cdot \text{in}^2])$	Mass [kg] (lb)
HF-SP702G1H HF-SP7024G1H	7.0	6165	1/6	177.4 (970)	111 (245)

[Unit: mm]

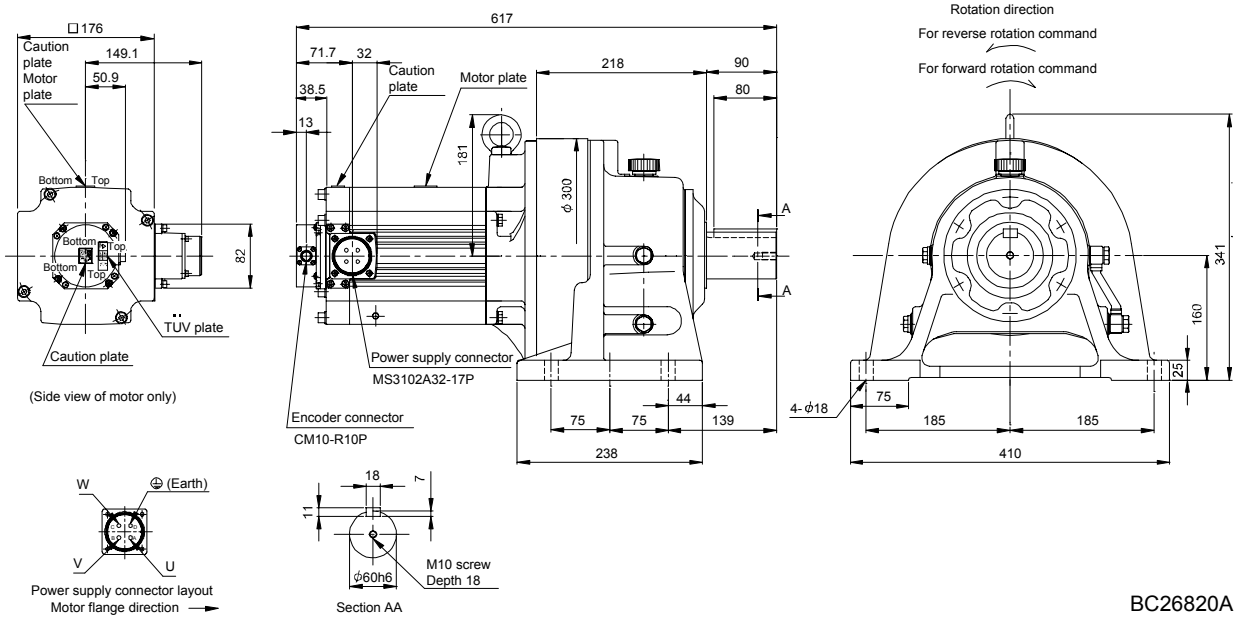

Model	Output [kW]	Reduction gear frame number	Reduction ratio (Actual reduction ratio)	Inertia moment $J [\times 10^{-4} \text{kg} \cdot \text{m}^2] (\text{WK}^2 [\text{oz} \cdot \text{in}^2])$	Mass [kg] (lb)
HF-SP702G1H HF-SP7024G1H	7.0	6170	1/11	190.2 (1040)	138 (304)
			1/17	182.7 (999)	

[Unit: mm]

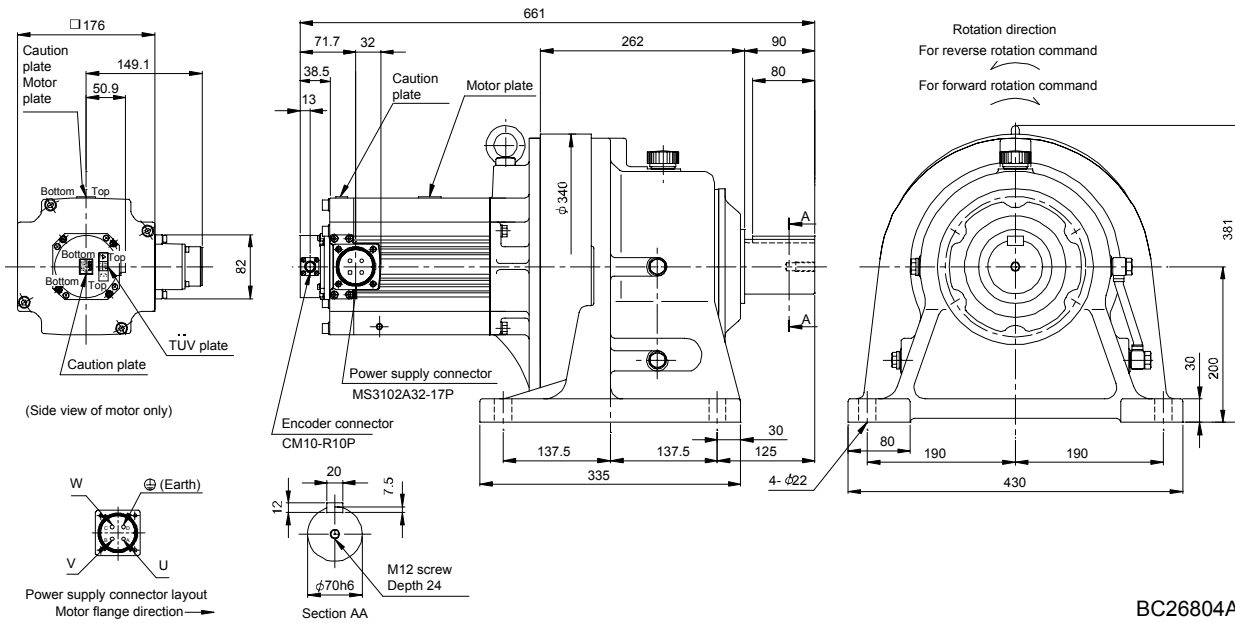

# 7. HF-SP SERIES

Model	Output [kW]	Reduction gear frame number	Reduction ratio (Actual reduction ratio)	Inertia moment $J [\times 10^{-4} \text{kg} \cdot \text{m}^2] (\text{WK}^2 [\text{oz} \cdot \text{in}^2])$	Mass [kg] ([lb])
HF-SP702G1H	7.0	6180	1/29	192.3 (1050)	180 (397)
HF-SP7024G1H			1/35	191.8 (1050)	

[Unit: mm]

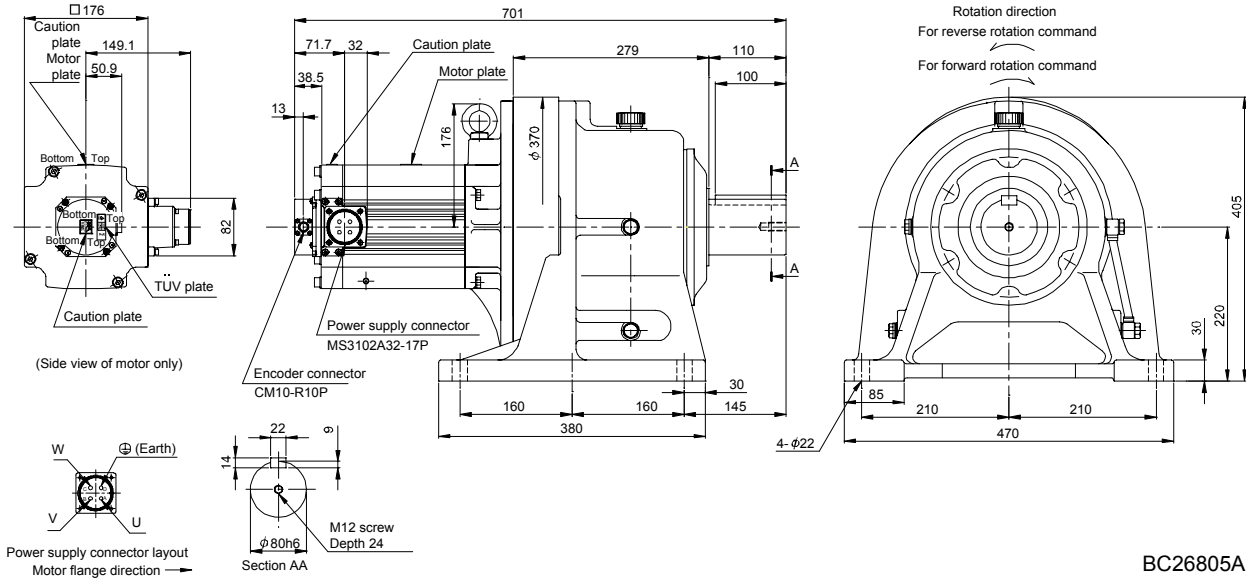

Model	Output [kW]	Reduction gear frame number	Reduction ratio (Actual reduction ratio)	Inertia moment $J [\times 10^{-4} \text{kg} \cdot \text{m}^2] (\text{WK}^2 [\text{oz} \cdot \text{in}^2])$	Mass [kg] ([lb])
HF-SP702G1H	7.0	6195	1/43	269.8 (1480)	261 (575)
HF-SP7024G1H			1/59	268.0 (1470)	

[Unit: mm]

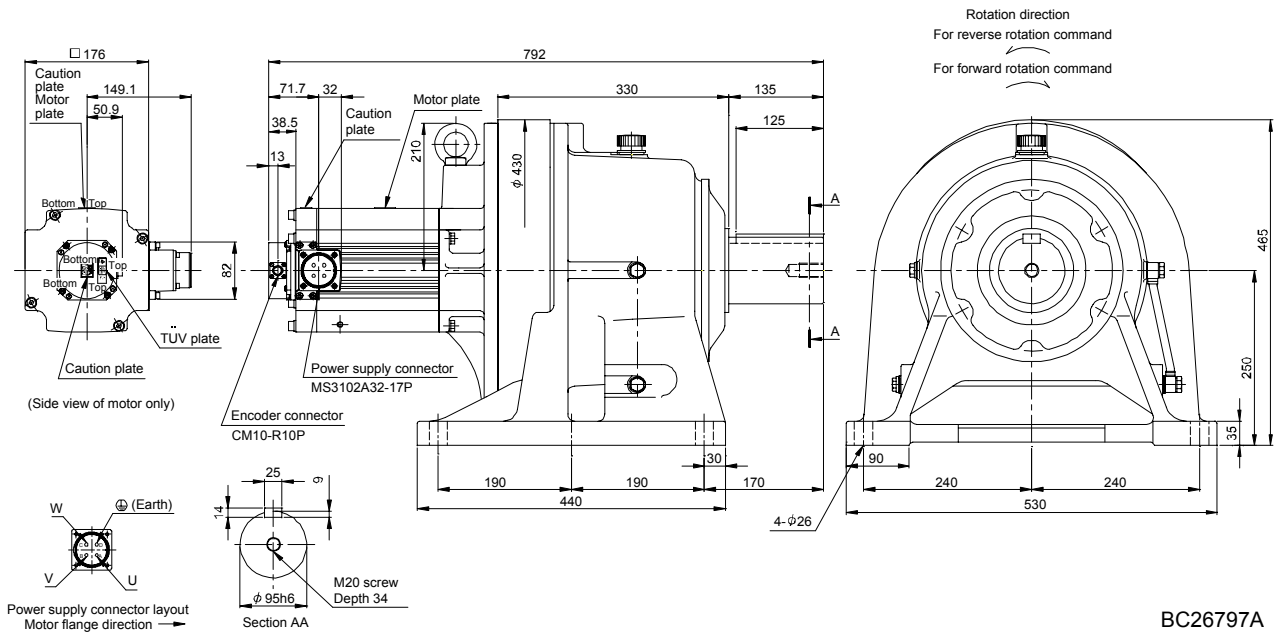

## 7. HF-SP SERIES

### 7.8.6 For general industrial machine with a reduction gear (leg type · with an electromagnetic brake)

Model	Output [kW]	Reduction gear frame number	Reduction ratio (Actual reduction ratio)	Brake static friction torque [N · m] ([oz · in])	Inertia moment J [ $\times 10^{-4}$ kg · m <sup>2</sup> ] (WK <sup>2</sup> [oz · in <sup>2</sup> ])	Mass [kg] ([lb])
HF-SP52BG1H HF-SP524BG1H	0.5	6100	1/6	8.5 (1200)	9.30 (50.8)	22.7 (50.0)
			1/11		8.80 (48.1)	
			1/17		8.70 (47.6)	
			1/29			

[Unit: mm]

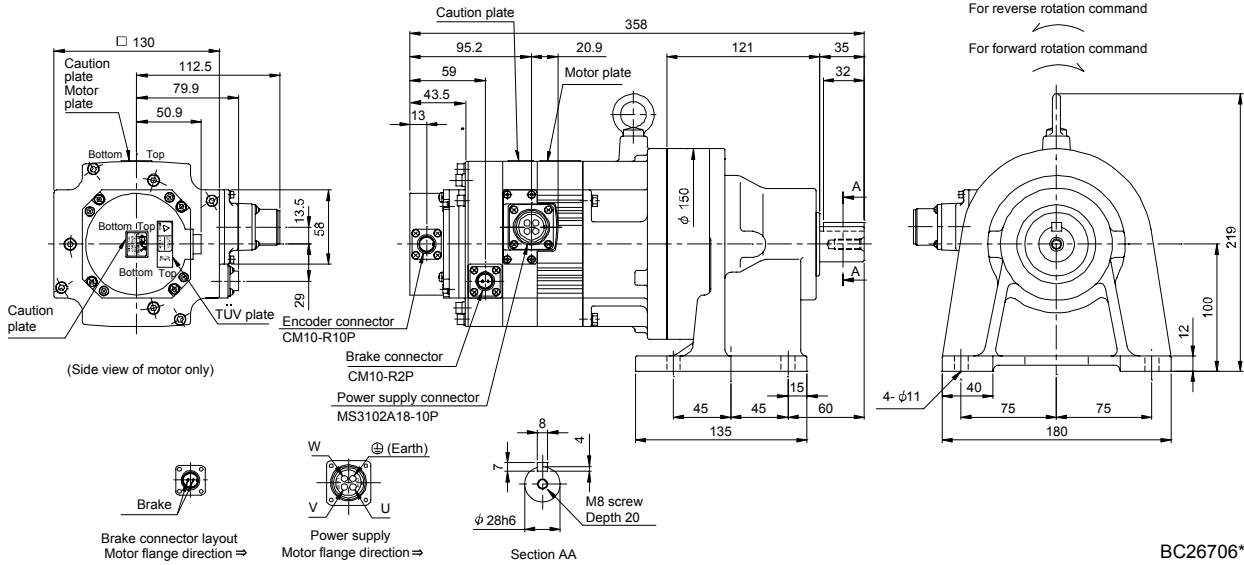

Model	Output [kW]	Reduction gear frame number	Reduction ratio (Actual reduction ratio)	Brake static friction torque [N · m] ([oz · in])	Inertia moment J [ $\times 10^{-4}$ kg · m <sup>2</sup> ] (WK <sup>2</sup> [oz · in <sup>2</sup> ])	Mass [kg] ([lb])
HF-SP52BG1H HF-SP524BG1H	0.5	6120	1/35	8.5 (1200)	9.40 (51.4)	29.7 (65.5)
			1/43			
			1/59			

[Unit: mm]

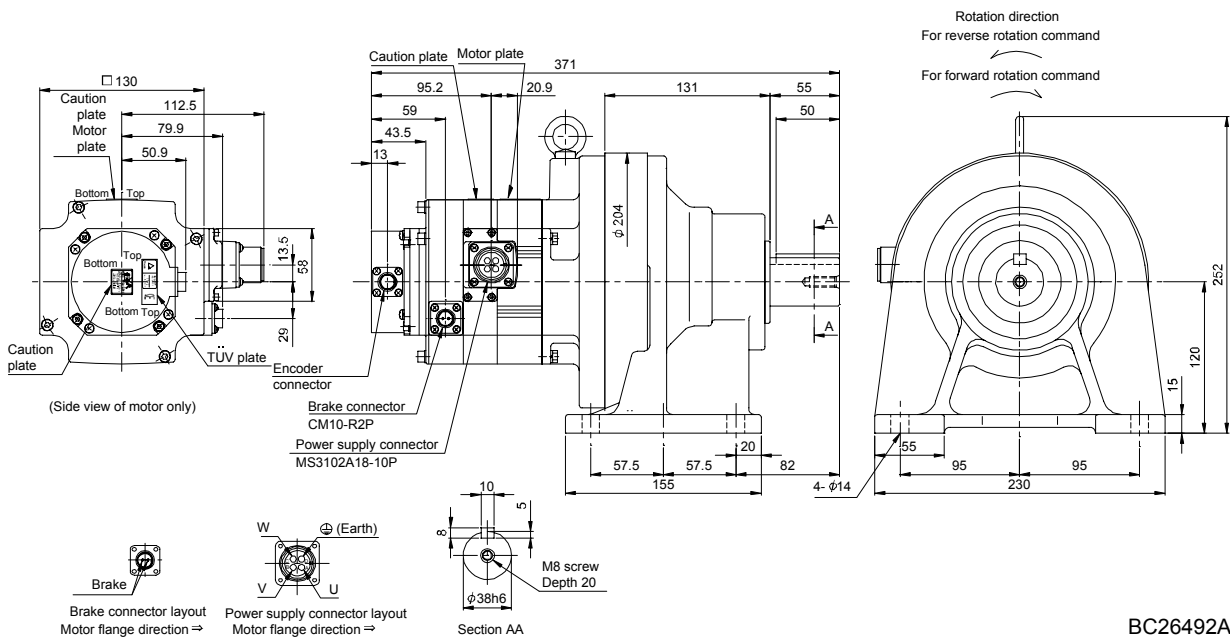

# 7. HF-SP SERIES

Model	Output [kW]	Reduction gear frame number	Reduction ratio (Actual reduction ratio)	Brake static friction torque [N · m] ([oz · in])	Inertia moment $J [\times 10^{-4} \text{kg} \cdot \text{m}^2]$ ( $\text{WK}^2$ [oz · in <sup>2</sup> ])	Mass [kg] ([lb])
HF-SP102BG1H HF-SP1024BG1H	1.0	6120	1/6	8.5 (1200)	17.5 (95.7)	31.5 (69.4)
			1/11		16.0 (87.5)	
			1/17		15.6 (85.3)	
			1/29		15.3 (83.7)	
			1/35			

[Unit: mm]

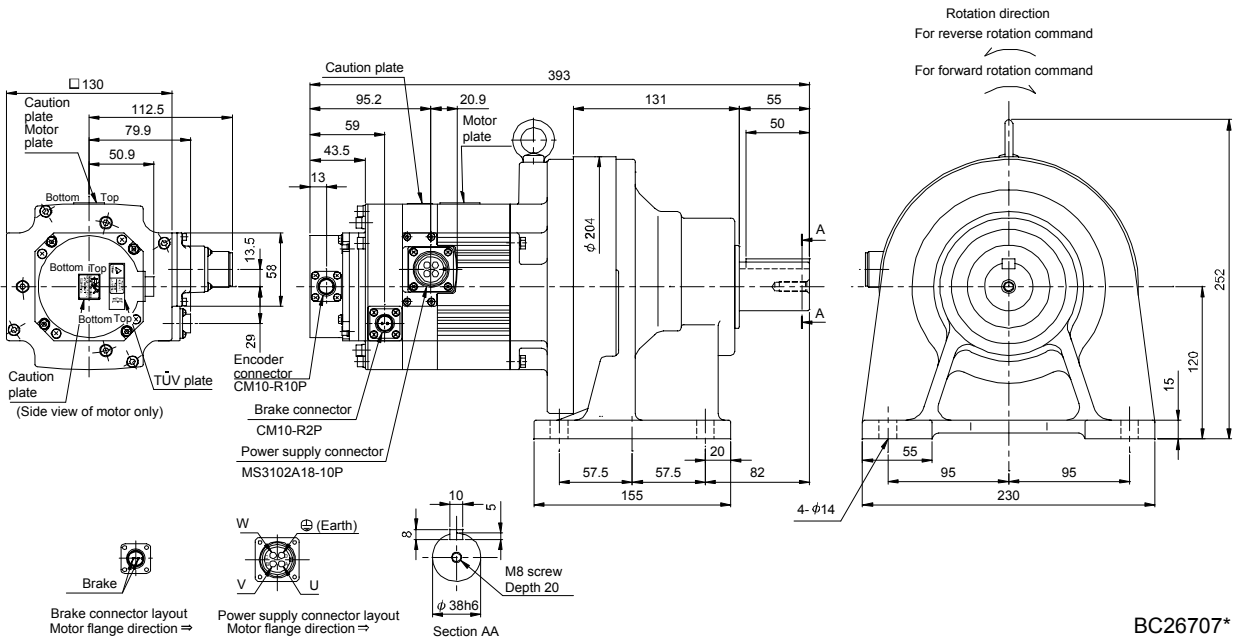

Model	Output [kW]	Reduction gear frame number	Reduction ratio (Actual reduction ratio)	Brake static friction torque [N · m] ([oz · in])	Inertia moment $J [\times 10^{-4} \text{kg} \cdot \text{m}^2]$ ( $\text{WK}^2$ [oz · in <sup>2</sup> ])	Mass [kg] ([lb])
HF-SP102BG1H HF-SP1024BG1H	1.0	6130	1/43	8.5 (1200)	16.5 (90.2)	52.5 (116)

[Unit: mm]

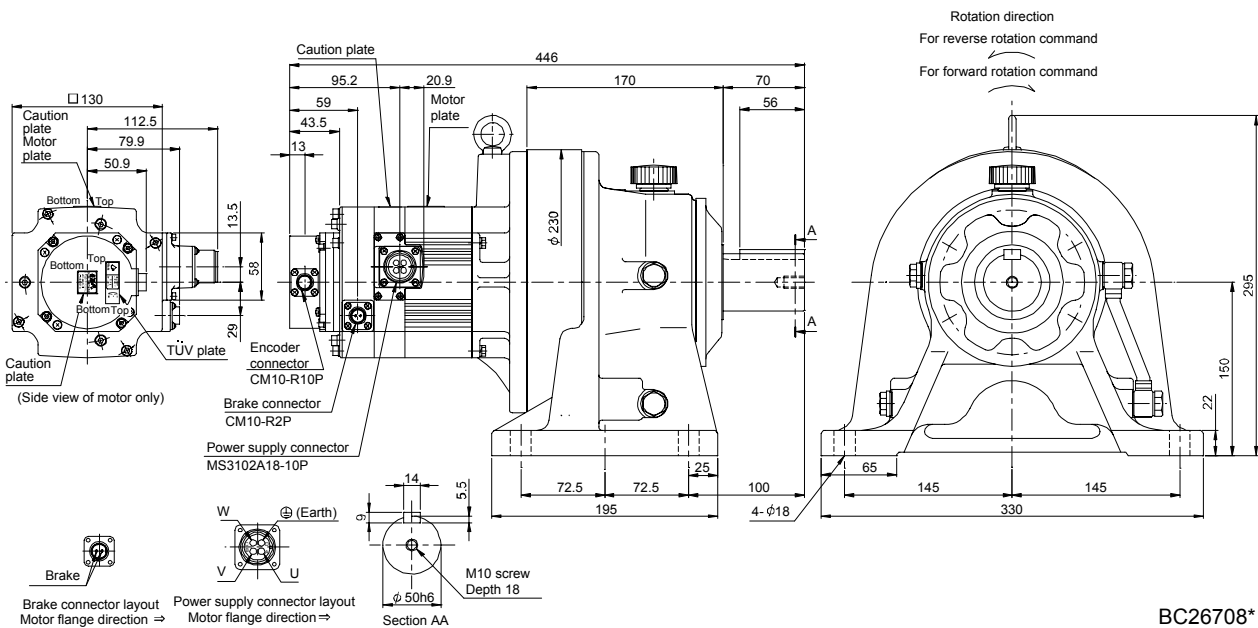



# 7. HF-SP SERIES

Model	Output [kW]	Reduction gear frame number	Reduction ratio (Actual reduction ratio)	Brake static friction torque [N · m] ([oz · in])	Inertia moment J [ $\times 10^{-4}$ kg · m <sup>2</sup> ] (WK <sup>2</sup> [oz · in <sup>2</sup> ])	Mass [kg] ([lb])
HF-SP102BG1H HF-SP1024BG1H	1.0	6160	1/59	8.5 (1200)	22.4 (122)	91.5 (202)

[Unit: mm]

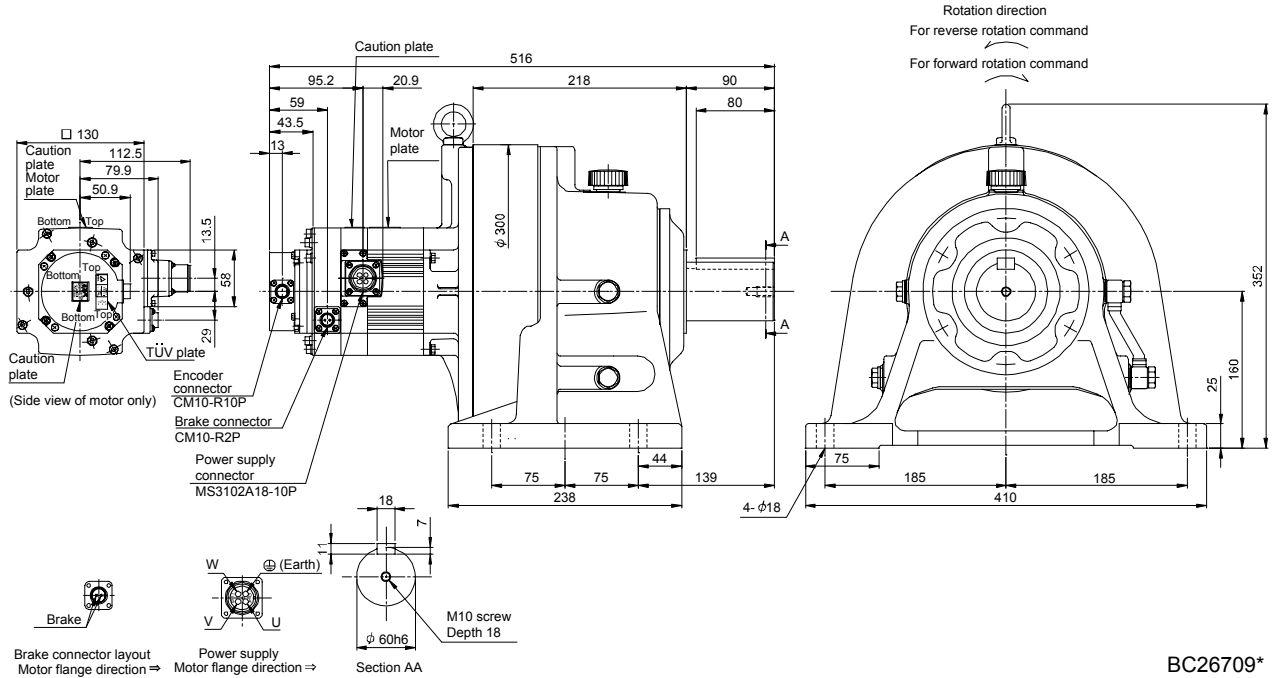

Model	Output [kW]	Reduction gear frame number	Reduction ratio (Actual reduction ratio)	Brake static friction torque [N · m] ([oz · in])	Inertia moment J [ $\times 10^{-4}$ kg · m <sup>2</sup> ] (WK <sup>2</sup> [oz · in <sup>2</sup> ])	Mass [kg] ([lb])
HF-SP152BG1H HF-SP1524BG1H	1.5	6120	1/6 1/11 1/17	8.5 (1200)	23.4 (128) 21.9 (120) 21.6 (118)	33.3 (73.4)

[Unit: mm]

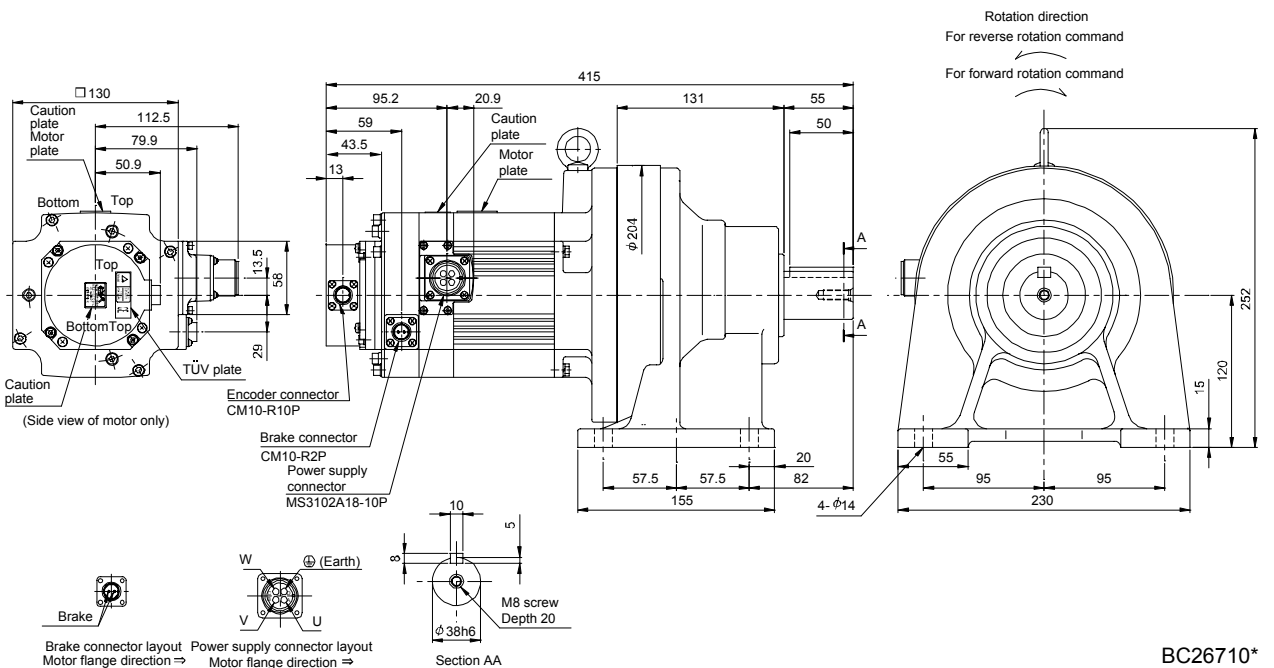

# 7. HF-SP SERIES

Model	Output [kW]	Reduction gear frame number	Reduction ratio (Actual reduction ratio)	Brake static friction torque [N · m] ([oz · in])	Inertia moment $J$ [ $\times 10^{-4} \text{kg} \cdot \text{m}^2$ ] ( $\text{WK}^2$ [oz · in <sup>2</sup> ])	Mass [kg] ([lb])
HF-SP152BG1H	1.5	6130	1/29	8.5 (1200)	22.6 (124)	54.3 (120)
HF-SP1524BG1H			1/35		22.5 (123)	

[Unit: mm]

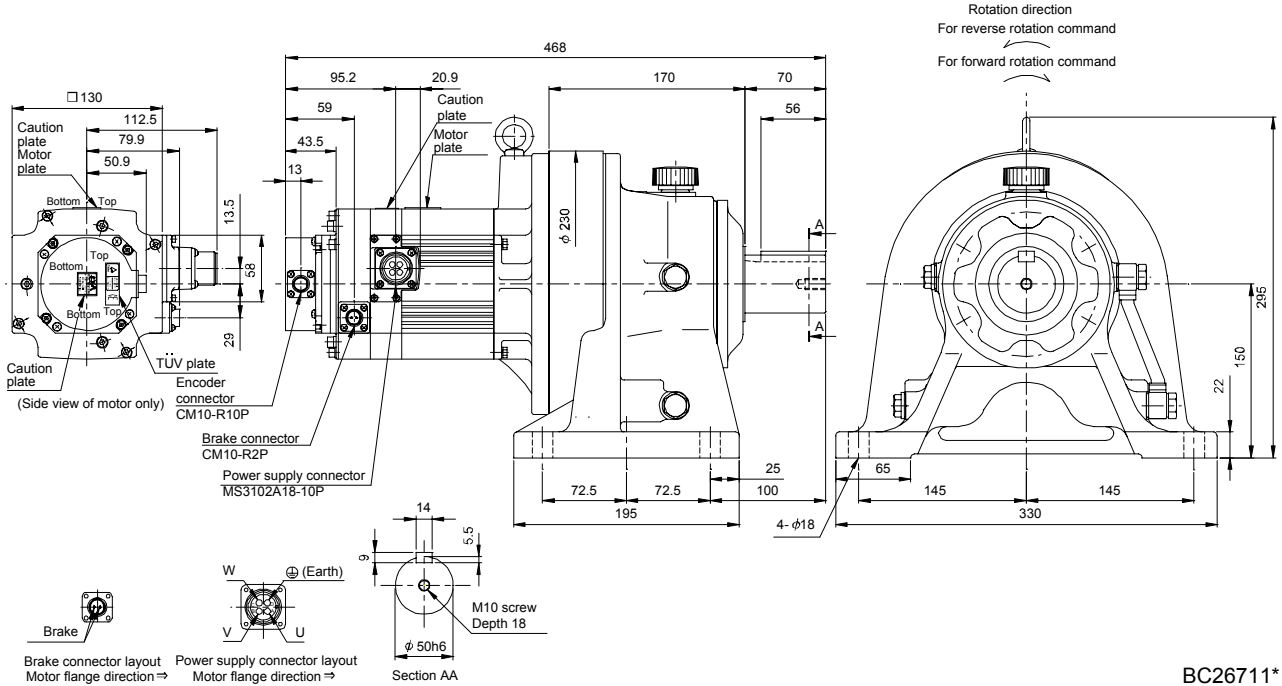

BC26711\*

Model	Output [kW]	Reduction gear frame number	Reduction ratio (Actual reduction ratio)	Brake static friction torque [N · m] ([oz · in])	Inertia moment $J$ [ $\times 10^{-4} \text{kg} \cdot \text{m}^2$ ] ( $\text{WK}^2$ [oz · in <sup>2</sup> ])	Mass [kg] ([lb])
HF-SP152BG1H	1.5	6160	1/43	8.5 (1200)	28.4 (155)	93.3 (206)
HF-SP1524BG1H			1/59		28.3 (155)	

[Unit: mm]

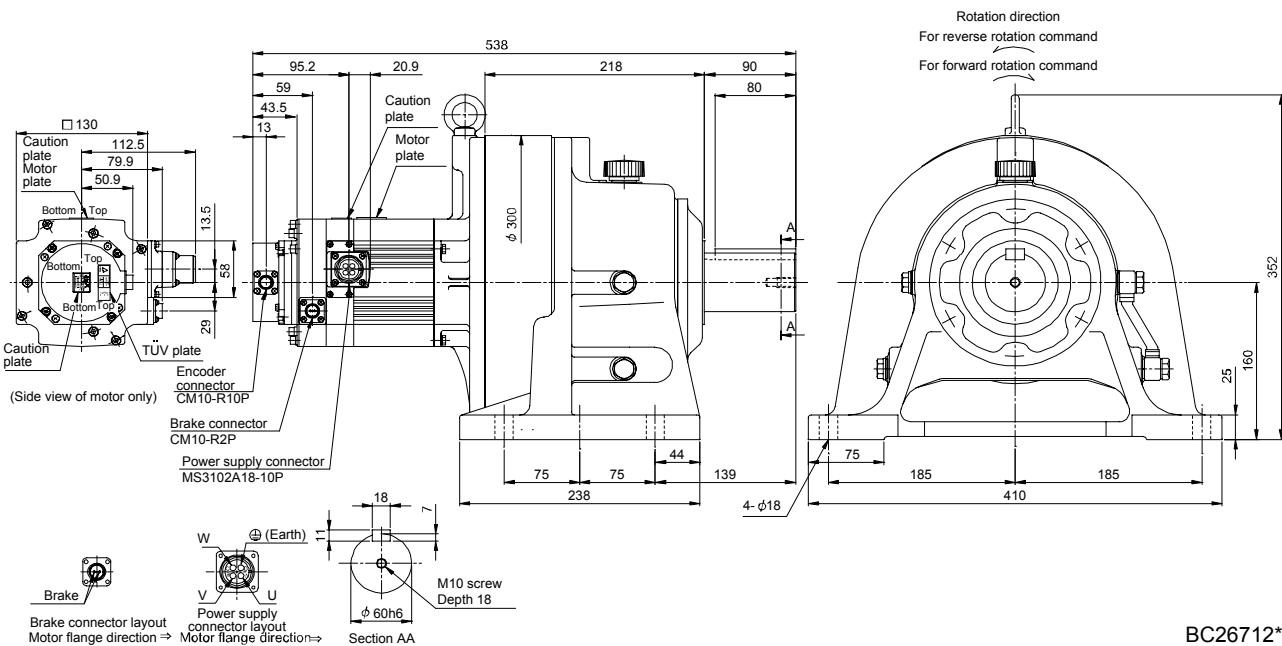

BC26712\*

# 7. HF-SP SERIES

Model	Output [kW]	Reduction gear frame number	Reduction ratio (Actual reduction ratio)	Brake static friction torque [N · m] ([oz · in])	Inertia moment J [ $\times 10^{-4}$ kg · m <sup>2</sup> ] (WK <sup>2</sup> [oz · in <sup>2</sup> ])	Mass [kg] ([lb])
HF-SP202BG1H HF-SP2024BG1H	2.0	6120	1/6	44 (6230)	51.7 (283)	41 (90.4)
			1/11		50.2 (274)	
			1/17		49.8 (272)	

[Unit: mm]

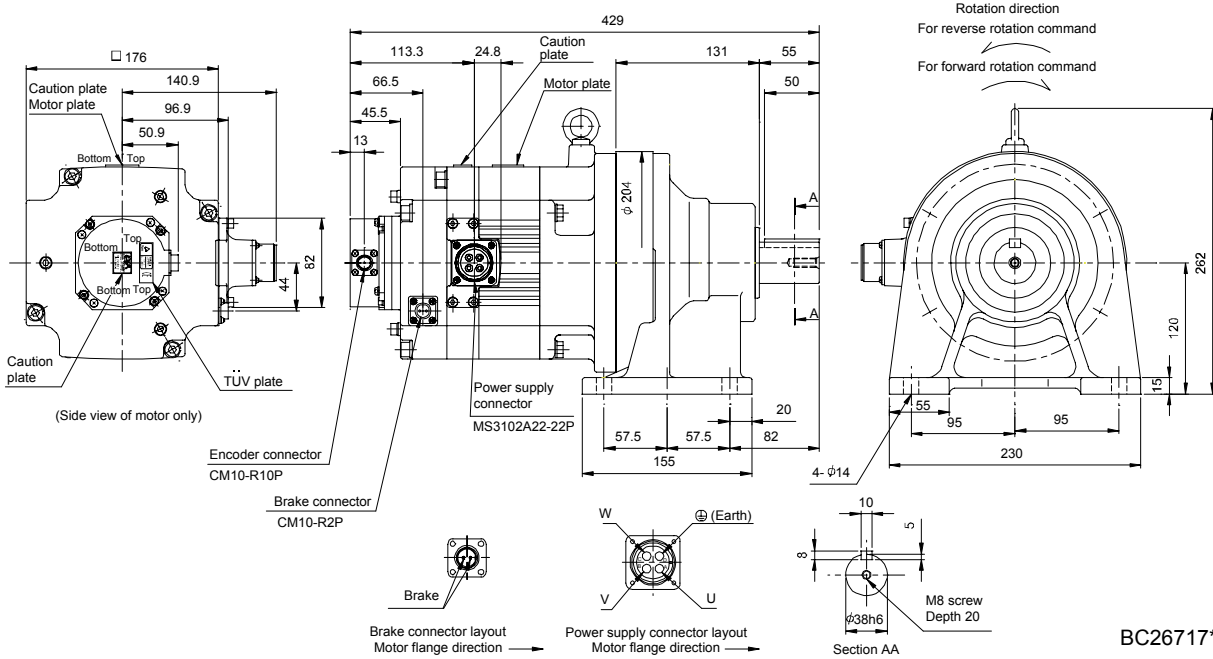

Model	Output [kW]	Reduction gear frame number	Reduction ratio (Actual reduction ratio)	Brake static friction torque [N · m] ([oz · in])	Inertia moment J [ $\times 10^{-4}$ kg · m <sup>2</sup> ] (WK <sup>2</sup> [oz · in <sup>2</sup> ])	Mass [kg] ([lb])
HF-SP202BG1H HF-SP2024BG1H	2.0	6165	1/29	44 (6230)	56.6 (309)	97 (214)
			1/35		56.4 (308)	
			1/43		56.1 (307)	
			1/59		56.0 (306)	

[Unit: mm]

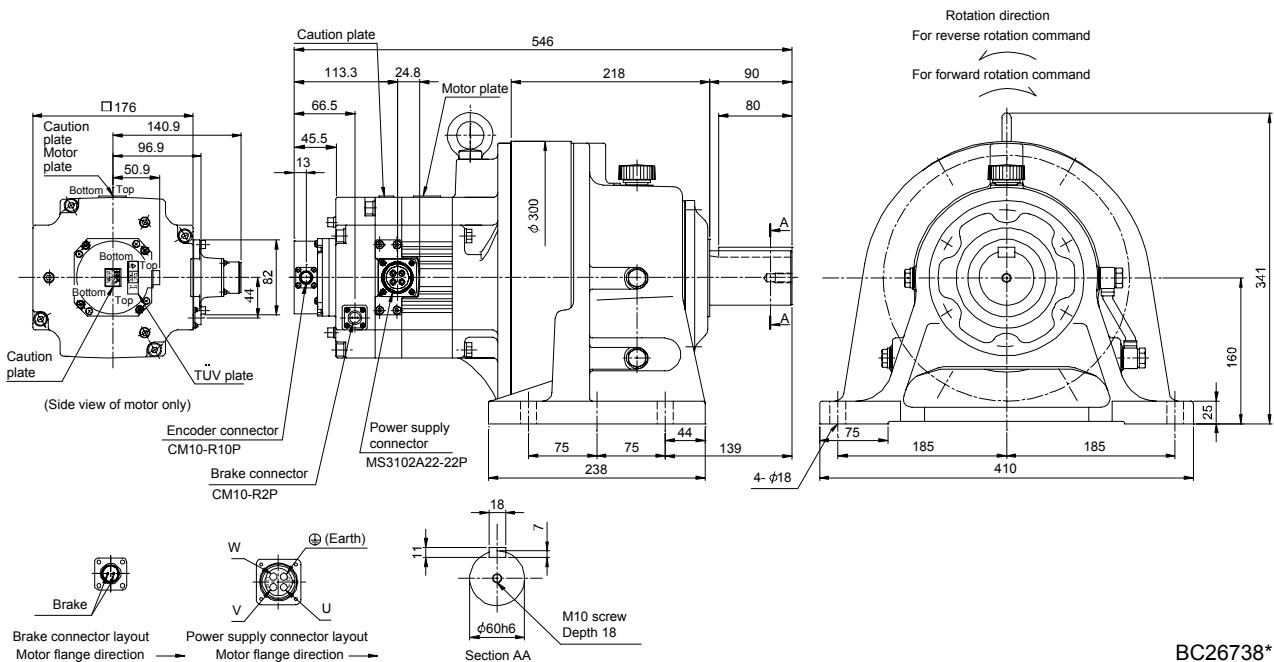

# 7. HF-SP SERIES

Model	Output [kW]	Reduction gear frame number	Reduction ratio (Actual reduction ratio)	Brake static friction torque [N · m] ([oz · in])	Inertia moment $J [\times 10^{-4} \text{kg} \cdot \text{m}^2] (\text{WK}^2 [\text{oz} \cdot \text{in}^2])$	Mass [kg] ([lb])
HF-SP352BG1H	3.5	6135	1/6	44 (6230)	94.0 (514)	66 (146)
HF-SP3524BG1H			1/11		89.8 (491)	
			1/17		88.5 (484)	

[Unit: mm]

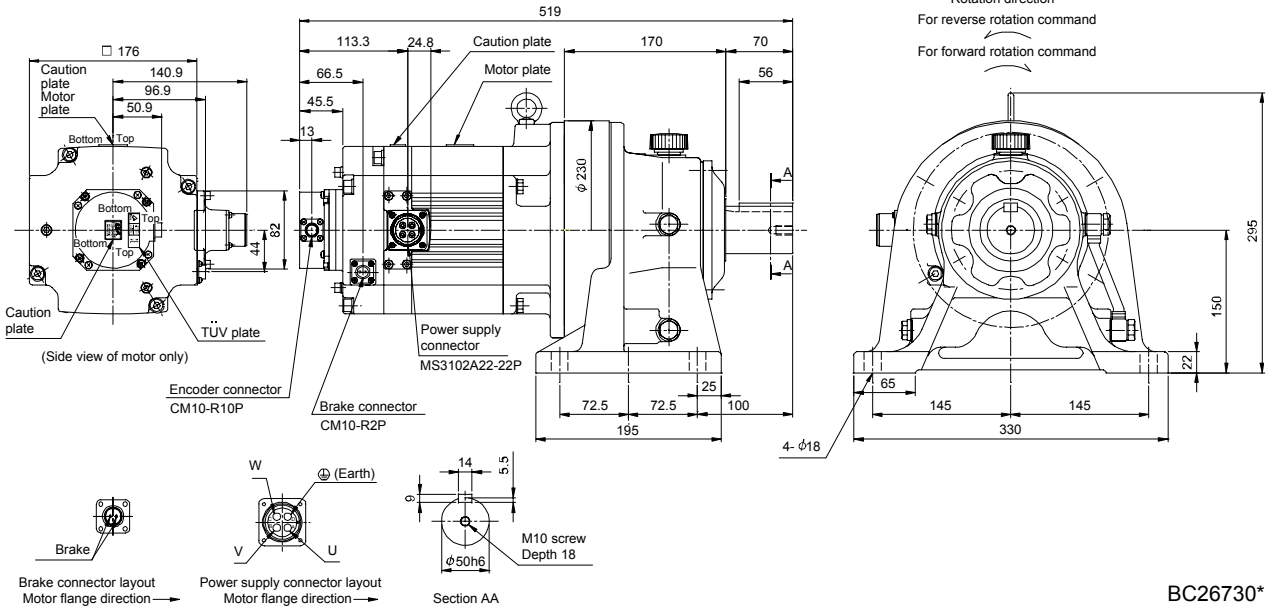

Model	Output [kW]	Reduction gear frame number	Reduction ratio (Actual reduction ratio)	Brake static friction torque [N · m] ([oz · in])	Inertia moment $J [\times 10^{-4} \text{kg} \cdot \text{m}^2] (\text{WK}^2 [\text{oz} \cdot \text{in}^2])$	Mass [kg] ([lb])
HF-SP352BG1H	3.5	6165	1/29	44 (6230)	93.6 (512)	104 (229)
HF-SP3524BG1H			1/35		93.3 (510)	

[Unit: mm]

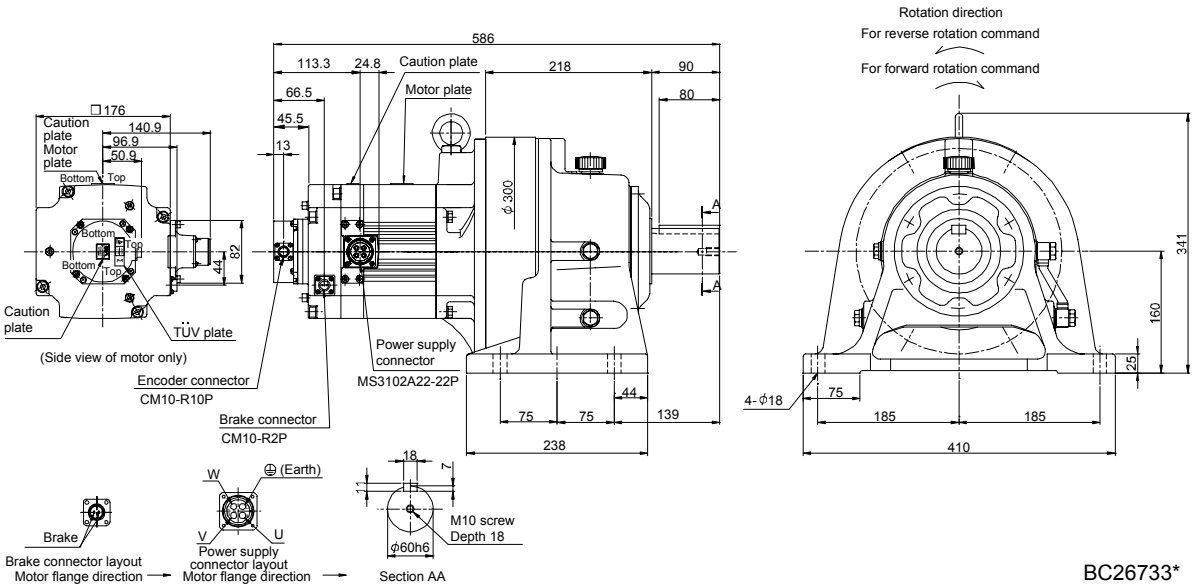

# 7. HF-SP SERIES

Model	Output [kW]	Reduction gear frame number	Reduction ratio (Actual reduction ratio)	Brake static friction torque [N · m] ([oz · in])	Inertia moment J [ $\times 10^{-4}$ kg · m <sup>2</sup> ] (WK <sup>2</sup> [oz · in <sup>2</sup> ])	Mass [kg] ([lb])
HF-SP352BG1H	3.5	6175	1/43	44 (6230)	111.5 (610)	145 (320)
HF-SP3524BG1H			1/59		110.9 (606)	

[Unit: mm]

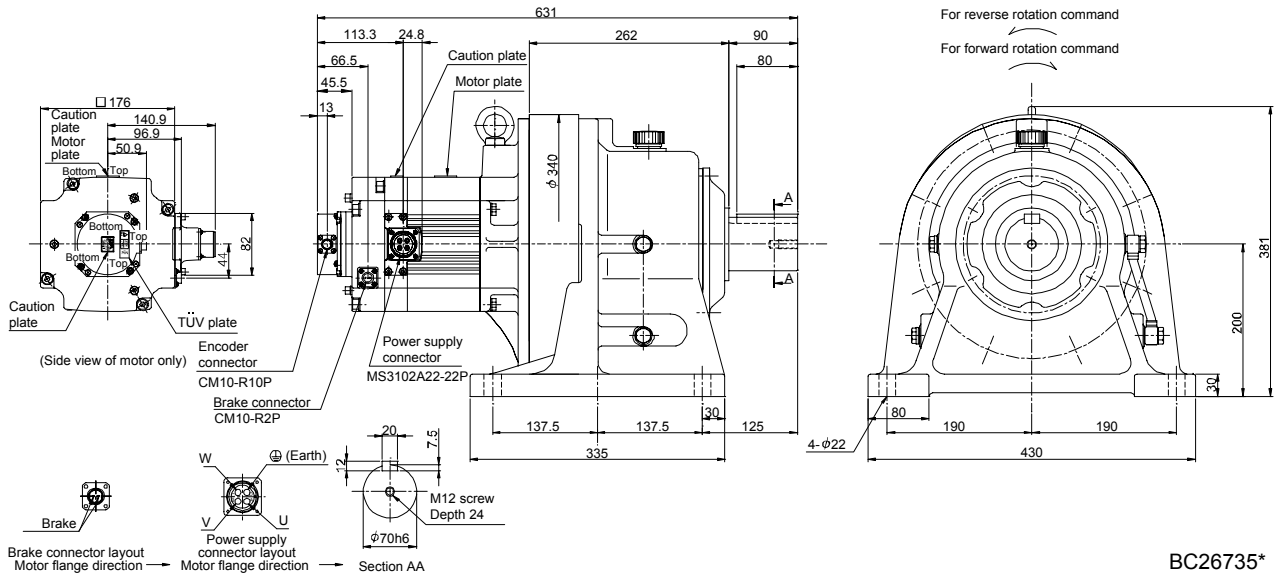

Model	Output [kW]	Reduction gear frame number	Reduction ratio (Actual reduction ratio)	Brake static friction torque [N · m] ([oz · in])	Inertia moment J [ $\times 10^{-4}$ kg · m <sup>2</sup> ] (WK <sup>2</sup> [oz · in <sup>2</sup> ])	Mass [kg] ([lb])
HF-SP502BG1H	5.0	6165	1/6	44 (6230)	130.8 (715)	108 (238)
HF-SP5024BG1H			1/11		118.5 (648)	
HF-SP5024BG1H			1/17		114.5 (626)	

[Unit: mm]

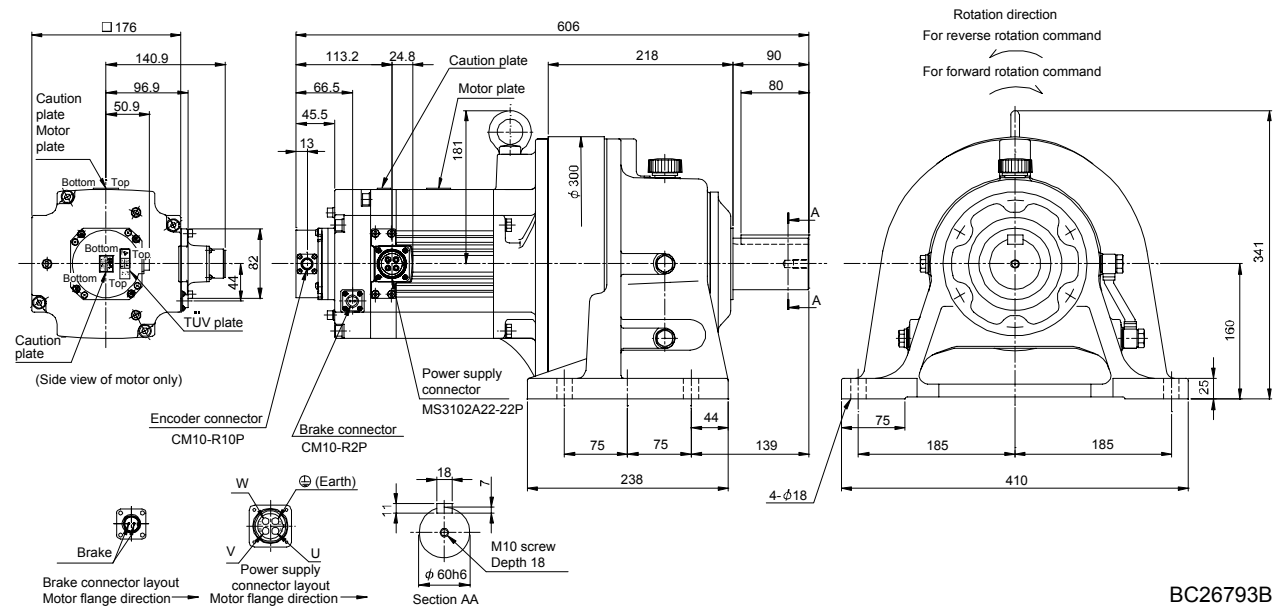

# 7. HF-SP SERIES

Model	Output [kW]	Reduction gear frame number	Reduction ratio (Actual reduction ratio)	Brake static friction torque [N · m] ([oz · in])	Inertia moment $J [\times 10^{-4} \text{kg} \cdot \text{m}^2]$ ( $\text{WK}^2$ [oz · in <sup>2</sup> ])	Mass [kg] ([lb])
HF-SP502BG1H	5.0	6180	1/29	44 (6230)	145.3 (794)	177 (390)
HF-SP5024BG1H			1/35		144.8 (792)	
			1/43		143.8 (786)	

[Unit: mm]

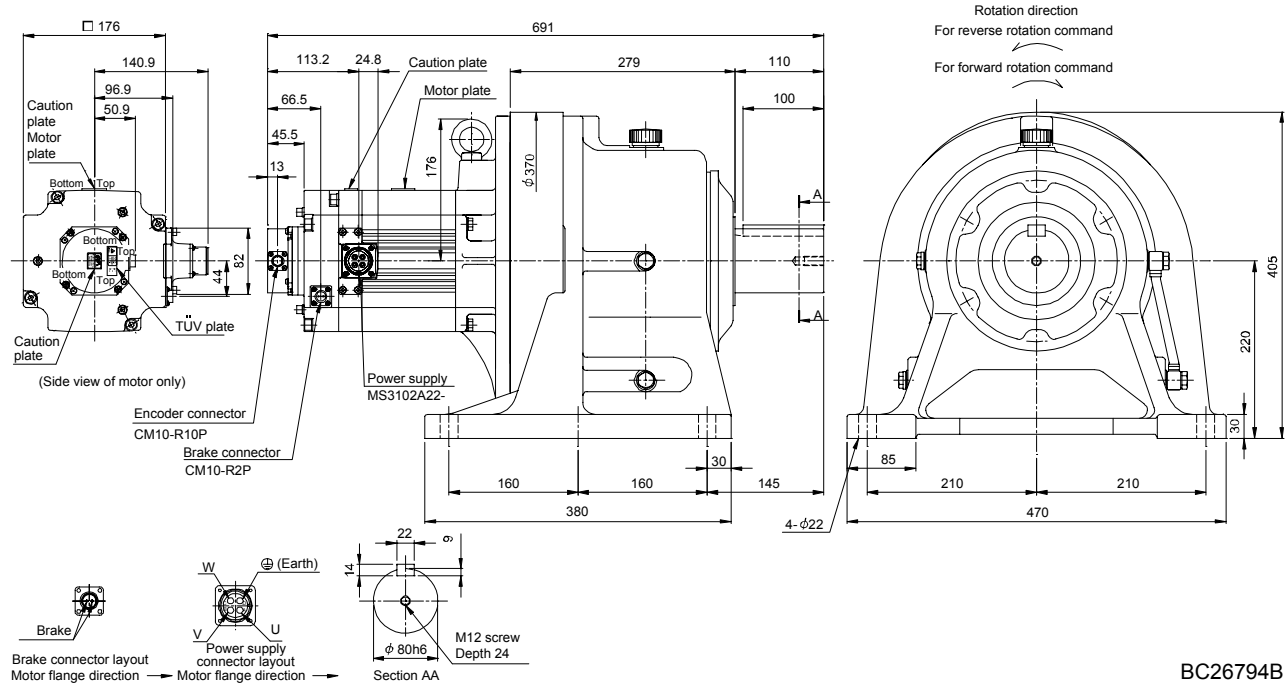

BC26794B

Model	Output [kW]	Reduction gear frame number	Reduction ratio (Actual reduction ratio)	Brake static friction torque [N · m] ([oz · in])	Inertia moment $J [\times 10^{-4} \text{kg} \cdot \text{m}^2]$ ( $\text{WK}^2$ [oz · in <sup>2</sup> ])	Mass [kg] ([lb])
HF-SP502BG1H	5.0	6185	1/59	44 (6230)	142.6 (780)	177 (390)
HF-SP5024BG1H						

[Unit: mm]

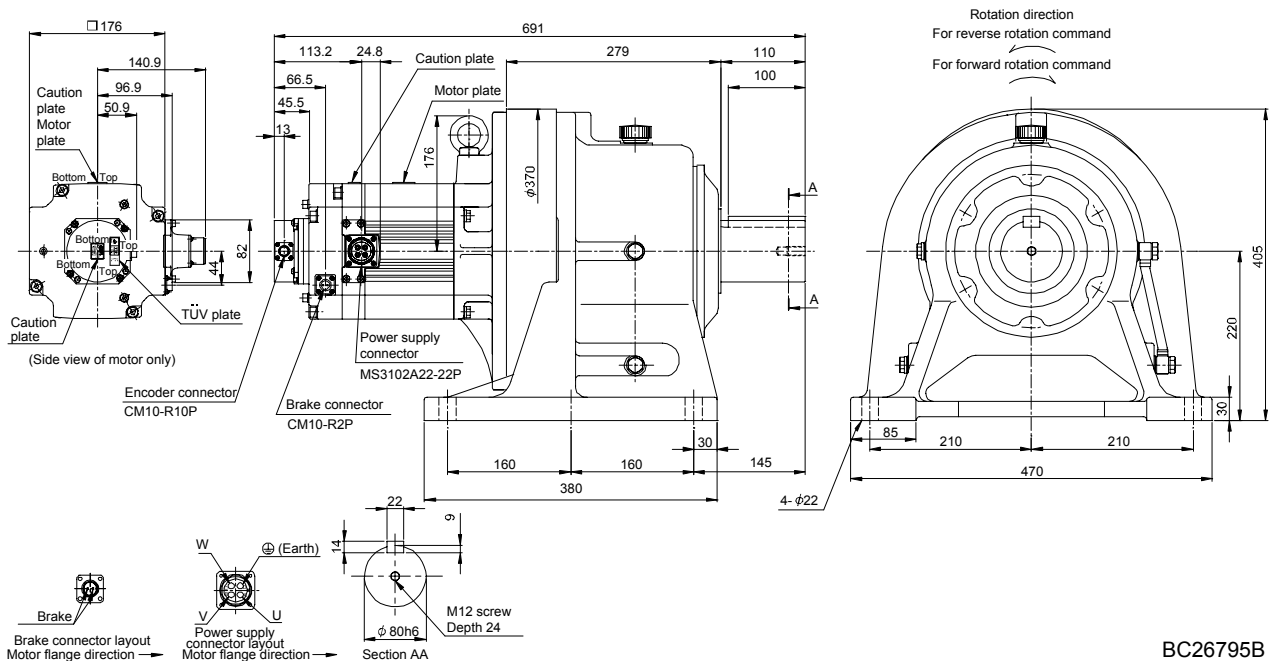

BC26795B

# 7. HF-SP SERIES

Model	Output [kW]	Reduction gear frame number	Reduction ratio (Actual reduction ratio)	Brake static friction torque [N · m] ([oz · in])	Inertia moment $J [\times 10^{-4} \text{kg} \cdot \text{m}^2] (\text{WK}^2 [\text{oz} \cdot \text{in}^2])$	Mass [kg] ([lb])
HF-SP702BG1H HF-SP7024BG1H	7.0	6165	1/6	44 (6230)	187.0 (1020)	117 (258)

[Unit: mm]

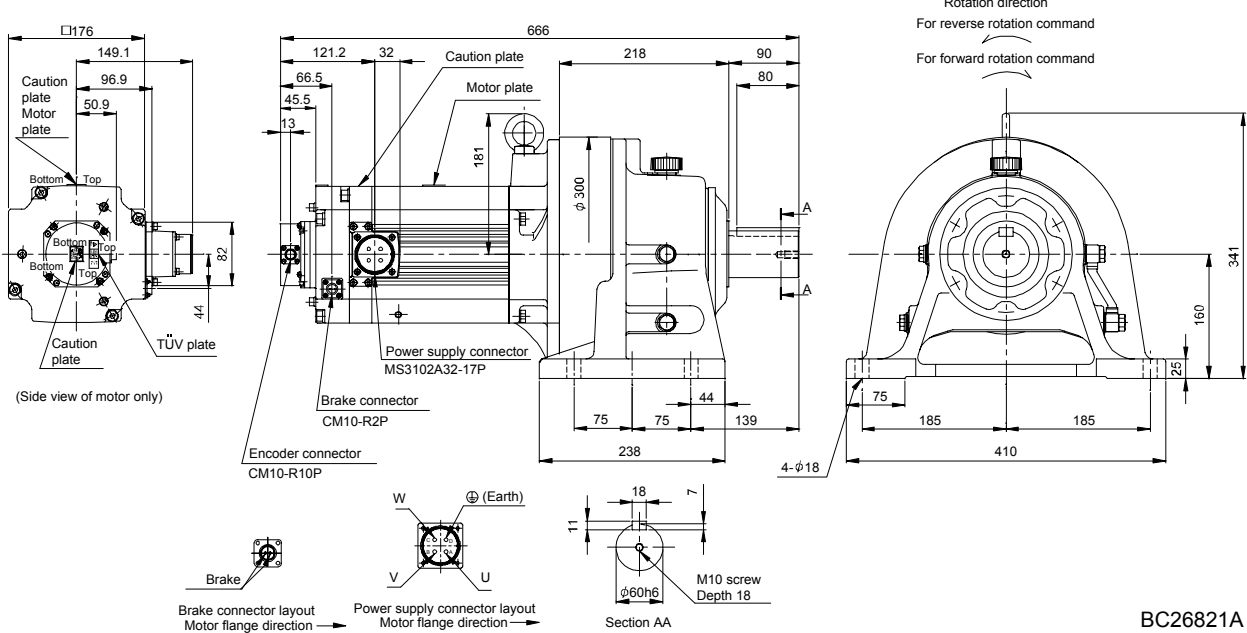

Model	Output [kW]	Reduction gear frame number	Reduction ratio (Actual reduction ratio)	Brake static friction torque [N · m] ([oz · in])	Inertia moment $J [\times 10^{-4} \text{kg} \cdot \text{m}^2] (\text{WK}^2 [\text{oz} \cdot \text{in}^2])$	Mass [kg] ([lb])
HF-SP702BG1H	7.0	6170	1/11	44 (6230)	199.9 (1090)	144 (317)
HF-SP7024BG1H			1/17		192.4 (1050)	

[Unit: mm]

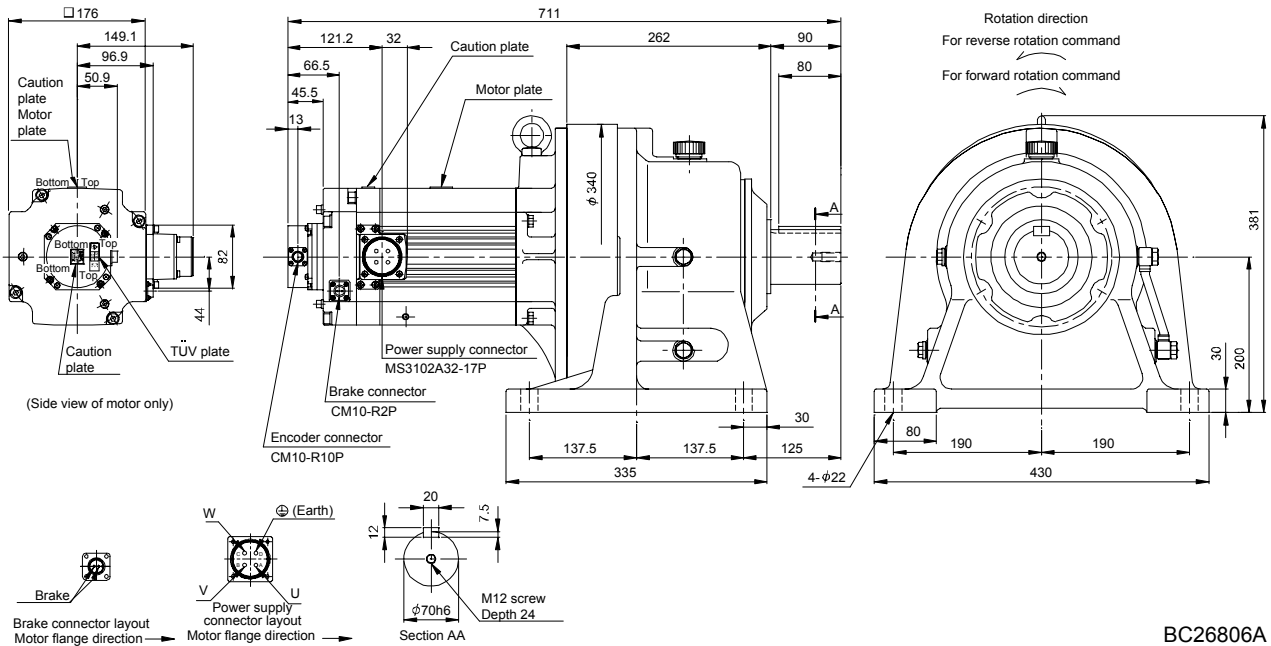

# 7. HF-SP SERIES

Model	Output [kW]	Reduction gear frame number	Reduction ratio (Actual reduction ratio)	Brake static friction torque [N · m] ([oz · in])	Inertia moment J [ $\times 10^{-4} \text{kg} \cdot \text{m}^2$ ] ( $\text{WK}^2$ [oz · in <sup>2</sup> ])	Mass [kg] ([lb])
HF-SP702BG1H	7.0	6180	1/29	44 (6230)	202.0 (1100)	186 (410)
HF-SP7024BG1H			1/35		201.5 (1100)	

[Unit: mm]

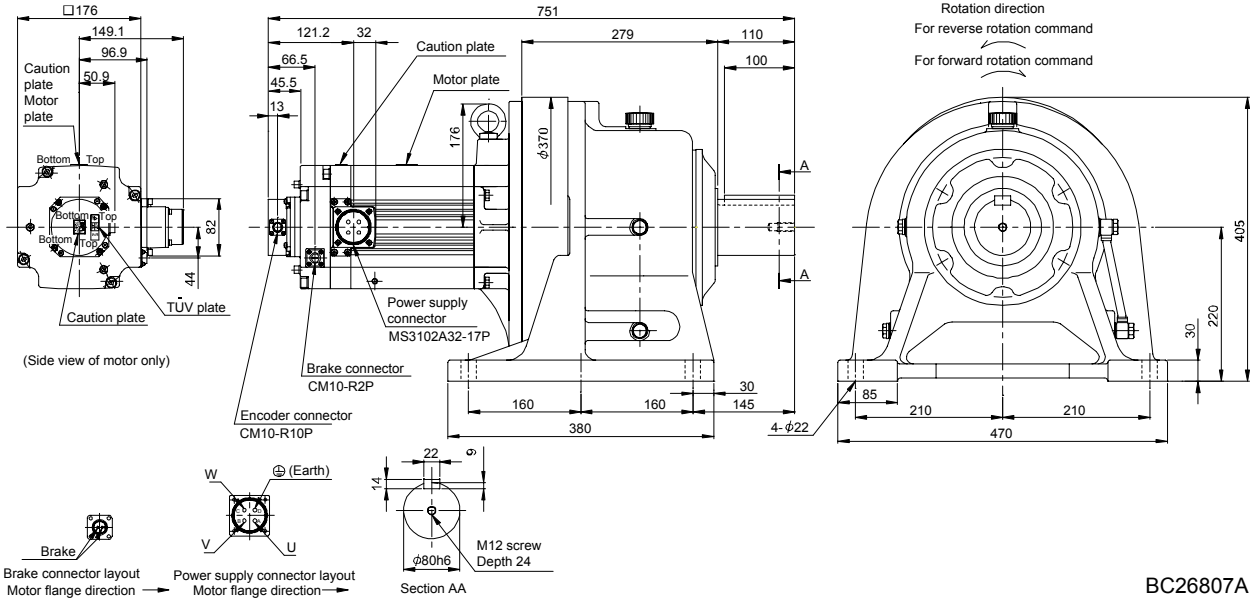

Model	Output [kW]	Reduction gear frame number	Reduction ratio (Actual reduction ratio)	Brake static friction torque [N · m] ([oz · in])	Inertia moment J [ $\times 10^{-4} \text{kg} \cdot \text{m}^2$ ] ( $\text{WK}^2$ [oz · in <sup>2</sup> ])	Mass [kg] ([lb])
HF-SP702BG1H	7.0	6195	1/43	44 (6230)	278.3 (1520)	267 (589)
HF-SP7024BG1H			1/59		276.5 (1510)	

[Unit: mm]

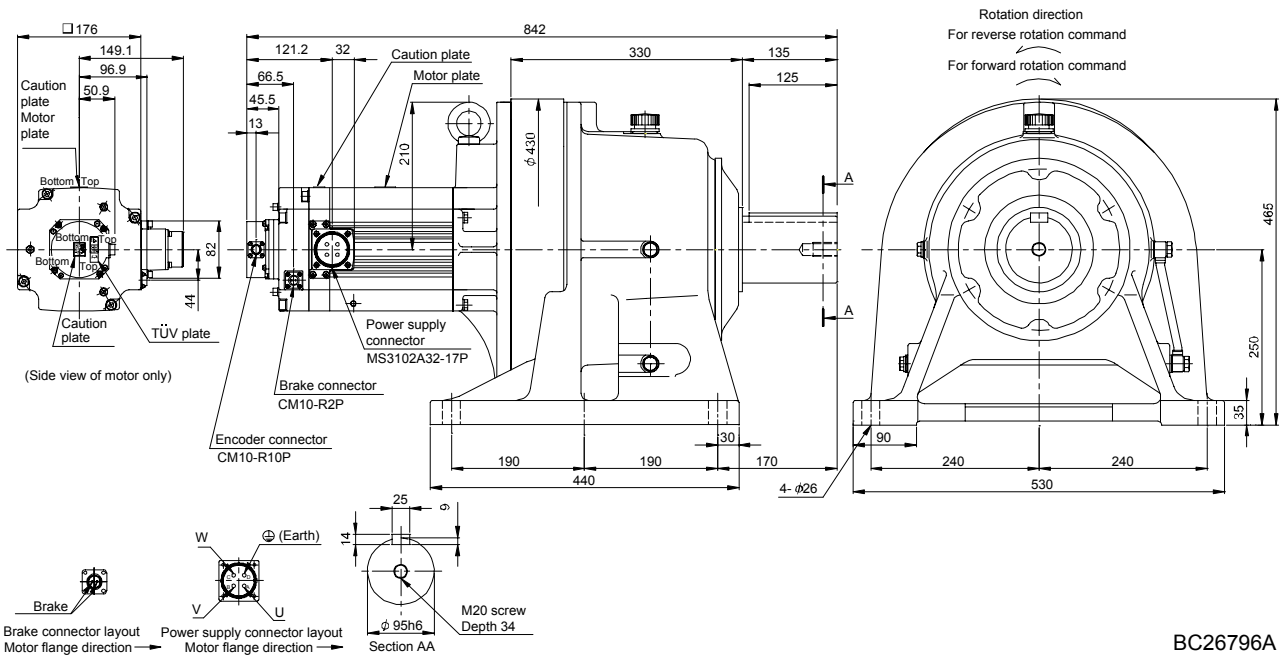



## 7. HF-SP SERIES

### 7.8.7 Flange-mounting flange output type for precision application compliant (without an electromagnetic brake)

Model	Output [kW]	Reduction gear model	Reduction ratio (Actual reduction ratio)	Inertia moment $J [\times 10^{-4} \text{kg} \cdot \text{m}^2] (\text{WK}^2 [\text{oz} \cdot \text{in}^2])$	Mass [kg] (lb)
HF-SP52G5	0.5	HPG-20A-05-FOKSAWS-S	1/5	6.75 (36.9)	7.6 (16.8)
HF-SP524G5		HPG-20A-11-FOKSAXS-S	1/11	6.66 (36.4)	7.8 (17.2)

[Unit: mm]

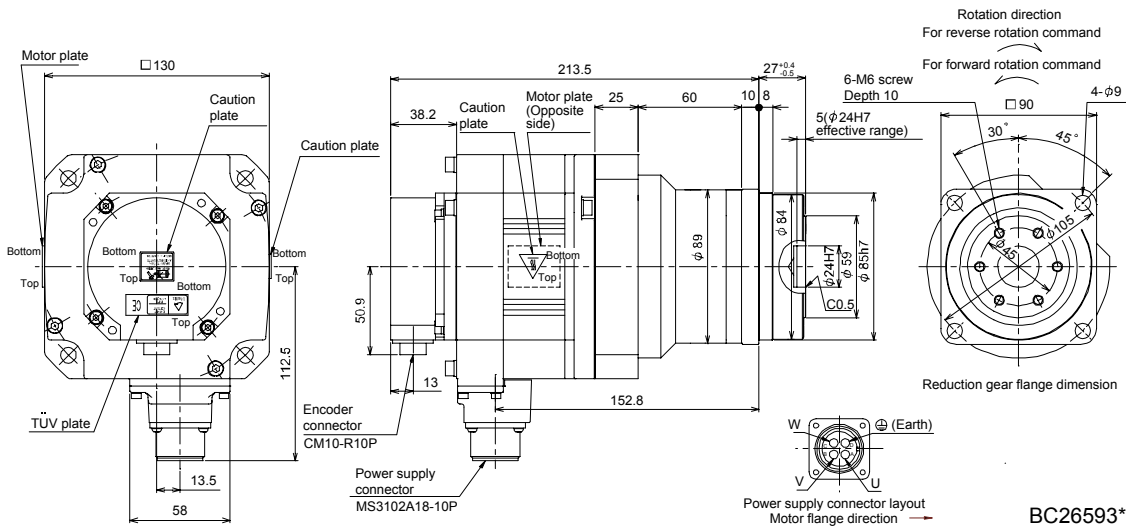

Model	Output [kW]	Reduction gear model	Reduction ratio (Actual reduction ratio)	Inertia moment $J [\times 10^{-4} \text{kg} \cdot \text{m}^2] (\text{WK}^2 [\text{oz} \cdot \text{in}^2])$	Mass [kg] (lb)
HF-SP52G5	0.5	HPG-32A-21-FOMCSYS-S	1/21	9.00 (49.2)	11.3 (24.9)
HF-SP524G5		HPG-32A-33-FOMCSZS-S	1/33	8.80 (48.1)	
		HPG-32A-45-FOMCSZS-S	1/45		

[Unit: mm]

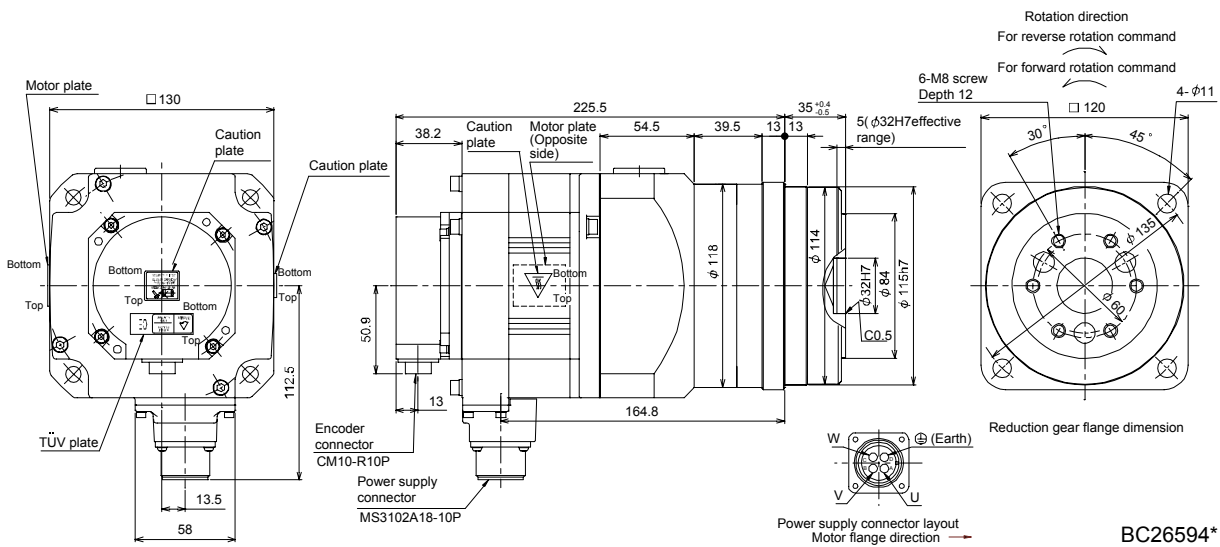

# 7. HF-SP SERIES

Model	Output [kW]	Reduction gear model	Reduction ratio (Actual reduction ratio)	Inertia moment $J [\times 10^{-4} \text{kg} \cdot \text{m}^2] (\text{WK}^2 [\text{oz} \cdot \text{in}^2])$	Mass [kg] ([lb])
HF-SP102G5 HF-SP1024G5	1.0	HPG-20A-05-FOKSAWS-S	1/5	12.6 (68.9)	9.3 (20.5)

[Unit: mm]

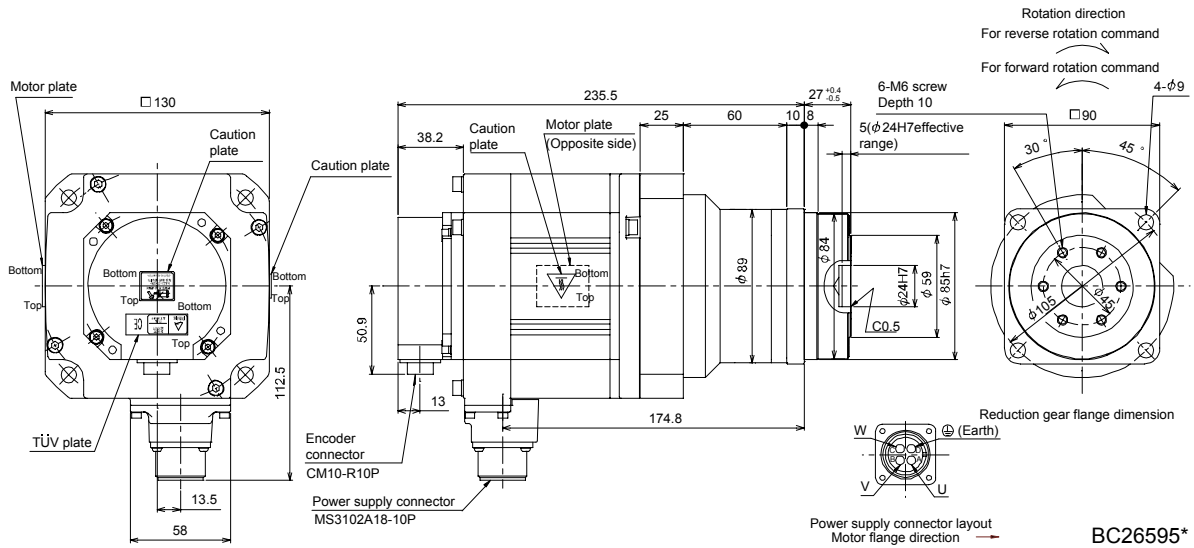

Model	Output [kW]	Reduction gear model	Reduction ratio (Actual reduction ratio)	Inertia moment $J [\times 10^{-4} \text{kg} \cdot \text{m}^2] (\text{WK}^2 [\text{oz} \cdot \text{in}^2])$	Mass [kg] ([lb])
HF-SP102G5	1.0	HPG-32A-11-FOMCSPS-S	1/11	15.2 (83.1)	13.0 (28.7)
HF-SP1024G5		HPG-32A-21-FOMCSYS-S	1/21	14.8 (80.9)	

[Unit: mm]

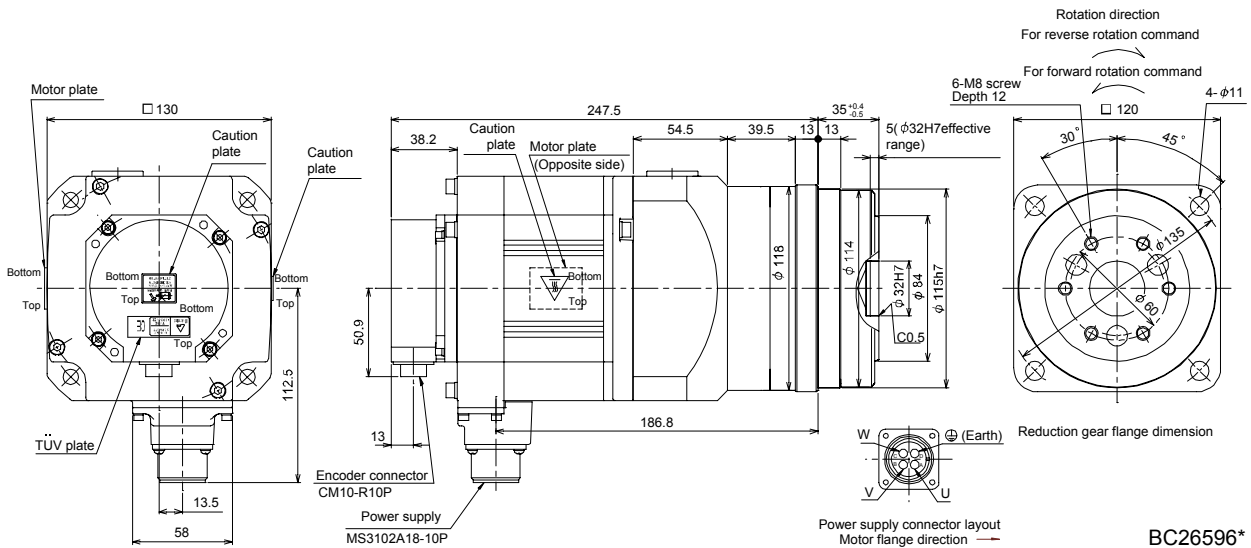

# 7. HF-SP SERIES

Model	Output [kW]	Reduction gear model	Reduction ratio (Actual reduction ratio)	Inertia moment $J [\times 10^{-4} \text{kg} \cdot \text{m}^2] (\text{WK}^2 [\text{oz} \cdot \text{in}^2])$	Mass [kg] (lb)
HF-SP102G5	1.0	HPG-50A-33-FOAABC-S	1/33	16.6 (90.8)	22.5 (49.6)
HF-SP1024G5		HPG-50A-45-FOAABC-S	1/45	16.5 (90.2)	

[Unit: mm]

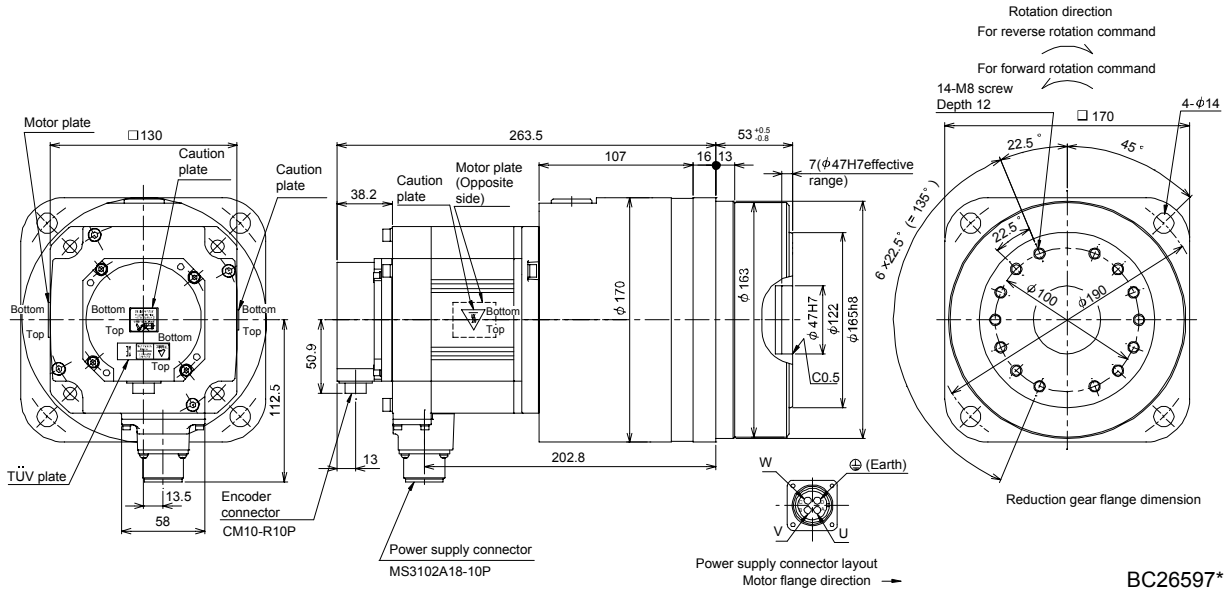

BC26597\*

Model	Output [kW]	Reduction gear model	Reduction ratio (Actual reduction ratio)	Inertia moment $J [\times 10^{-4} \text{kg} \cdot \text{m}^2] (\text{WK}^2 [\text{oz} \cdot \text{in}^2])$	Mass [kg] (lb)
HF-SP152G5	1.5	HPG-20A-05-FOKSAWS-S	1/5	18.5 (101)	11.1 (24.5)
HF-SP1524G5					

[Unit: mm]

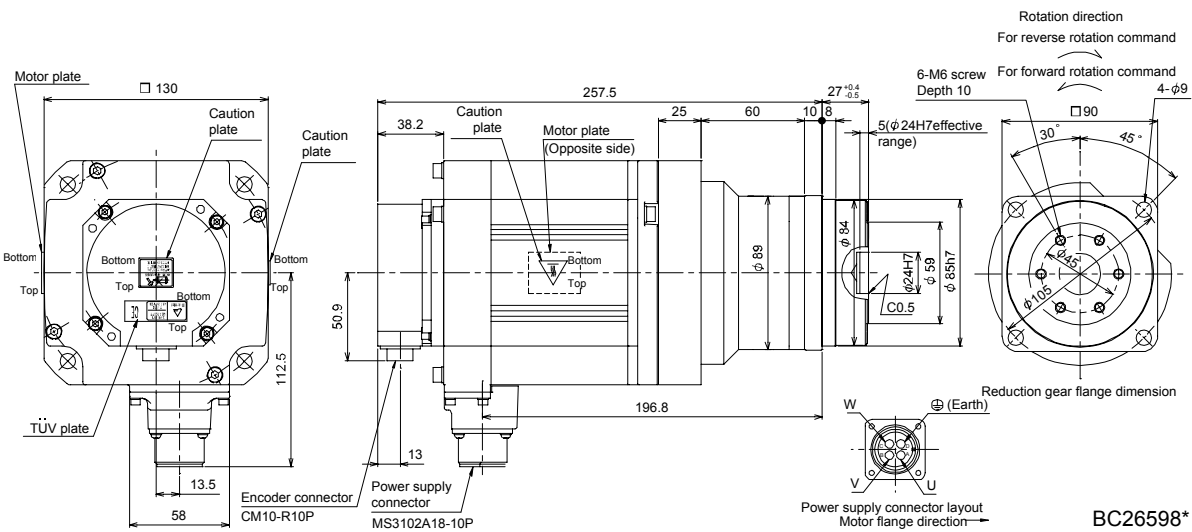

BC26598\*

# 7. HF-SP SERIES

Model	Output [kW]	Reduction gear model	Reduction ratio (Actual reduction ratio)	Inertia moment $J [\times 10^{-4} \text{kg} \cdot \text{m}^2] (\text{WK}^2 [\text{oz} \cdot \text{in}^2])$	Mass [kg] ([lb])
HF-SP152G5 HF-SP1524G5	1.5	HPG-32A-11-FOMCSPS-S	1/11	21.1 (115)	14.8 (32.6)

[Unit: mm]

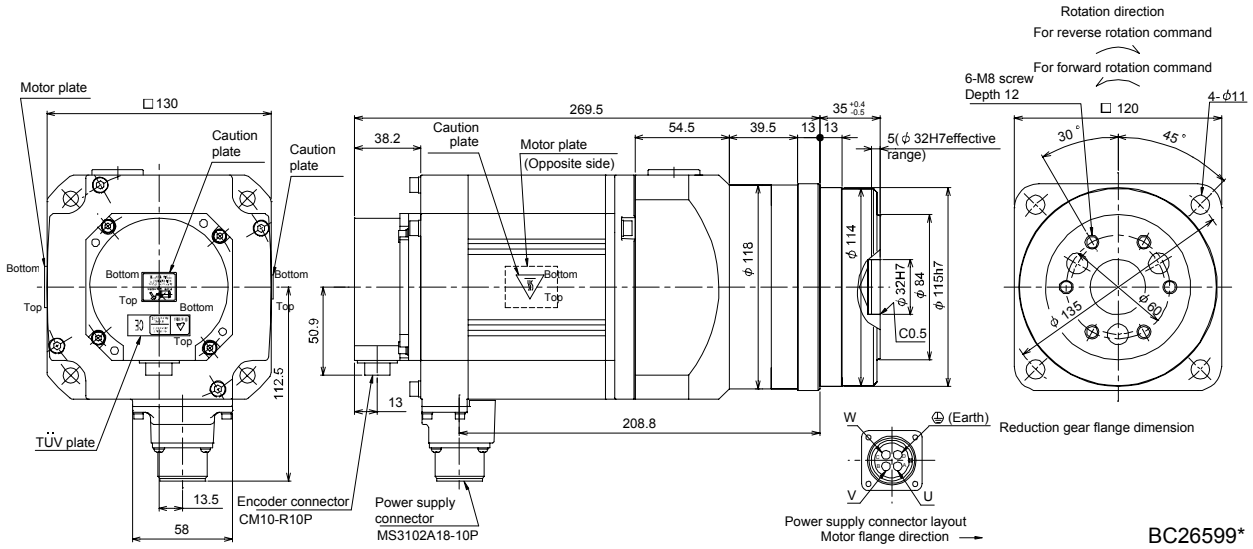

Model	Output [kW]	Reduction gear model	Reduction ratio (Actual reduction ratio)	Inertia moment $J [\times 10^{-4} \text{kg} \cdot \text{m}^2] (\text{WK}^2 [\text{oz} \cdot \text{in}^2])$	Mass [kg] ([lb])
HF-SP152G5 HF-SP1524G5	1.5	HPG-50A-21-FOAABC-S	1/21	23.5 (128)	24.3 (53.6)
		HPG-50A-33-FOAABC-S	1/33	22.5 (123)	
		HPG-50A-45-FOAABC-S	1/45	22.4 (122)	

[Unit: mm]

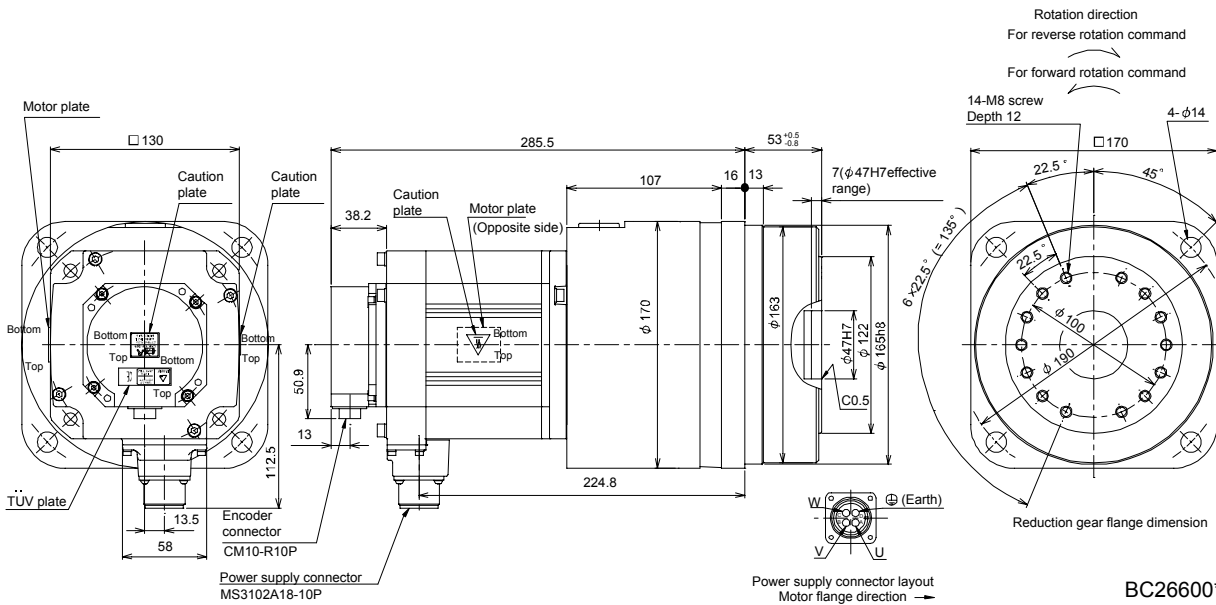

# 7. HF-SP SERIES

Model	Output [kW]	Reduction gear model	Reduction ratio (Actual reduction ratio)	Inertia moment $J [\times 10^{-4} \text{kg} \cdot \text{m}^2] (\text{WK}^2 [\text{oz} \cdot \text{in}^2])$	Mass [kg] ([lb])
HF-SP202G5	2.0	HPG-32A-05-FOPBZI-S	1/5	42.9 (235)	19.5 (43.0)
HF-SP2024G5		HPG-32A-11-FOPBZJ-S	1/11	42.7 (233)	20.0 (44.1)

[Unit: mm]

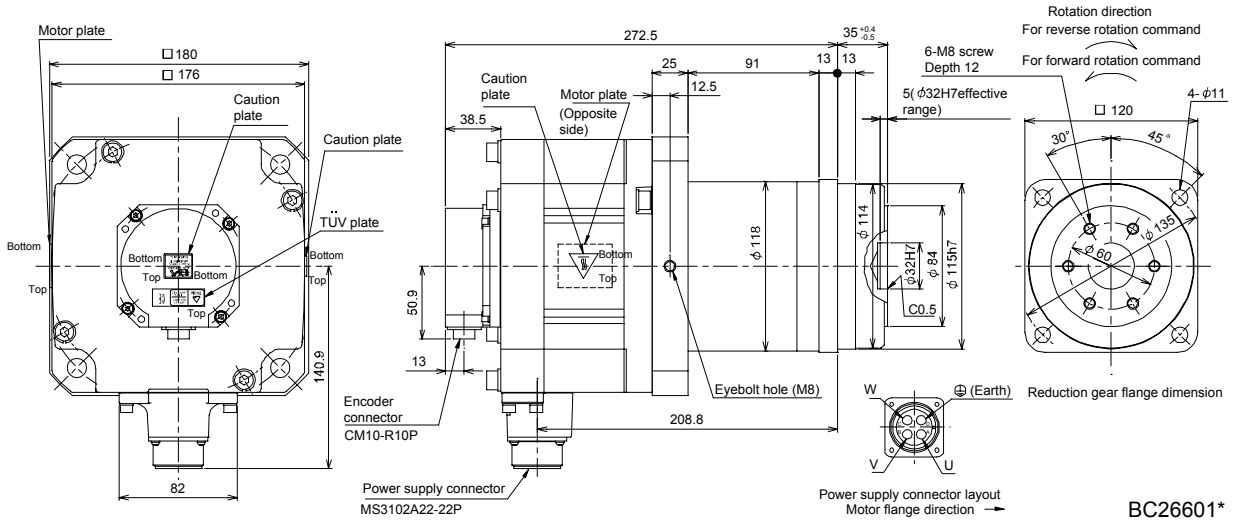

Model	Output [kW]	Reduction gear model	Reduction ratio (Actual reduction ratio)	Inertia moment $J [\times 10^{-4} \text{kg} \cdot \text{m}^2] (\text{WK}^2 [\text{oz} \cdot \text{in}^2])$	Mass [kg] ([lb])
HF-SP202G5	2.0	HPG-50A-21-FOBBD-F-S	1/21	44.7 (244)	29.1 (64.2)
HF-SP2024G5		HPG-50A-33-FOBBD-F-S	1/33	43.7 (239)	
		HPG-50A-45-FOBBD-F-S	1/45		

[Unit: mm]

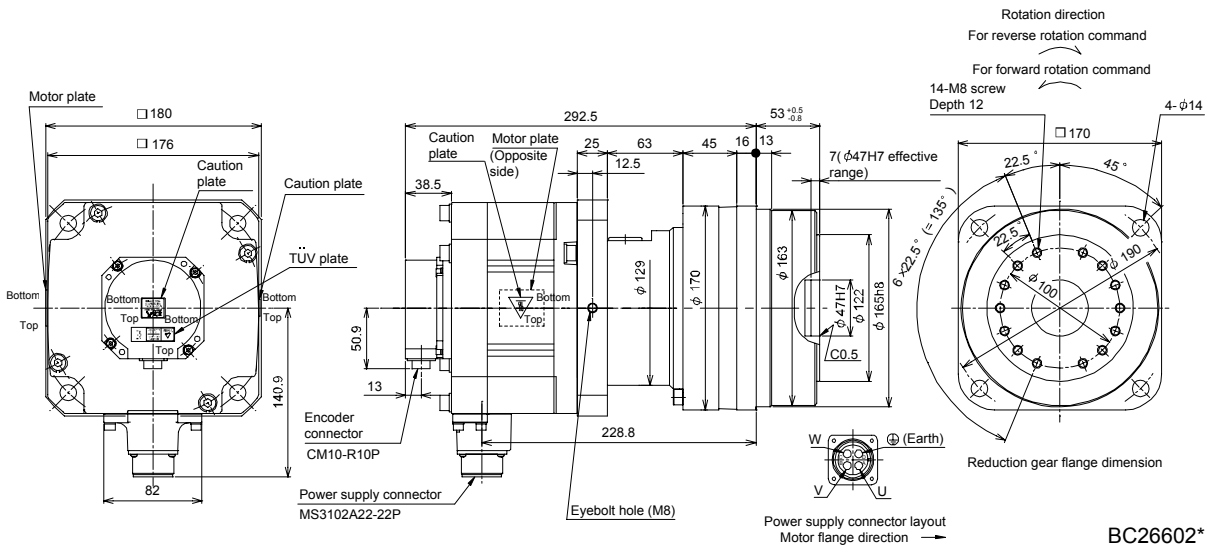

# 7. HF-SP SERIES

Model	Output [kW]	Reduction gear model	Reduction ratio (Actual reduction ratio)	Inertia moment $J [\times 10^{-4} \text{kg} \cdot \text{m}^2] (\text{WK}^2 [\text{oz} \cdot \text{in}^2])$	Mass [kg] ([lb])
HF-SP352G5 HF-SP3524G5	3.5	HPG-32A-05-FOPBZI-S	1/5	79.6 (435)	26.5 (58.4)

[Unit: mm]

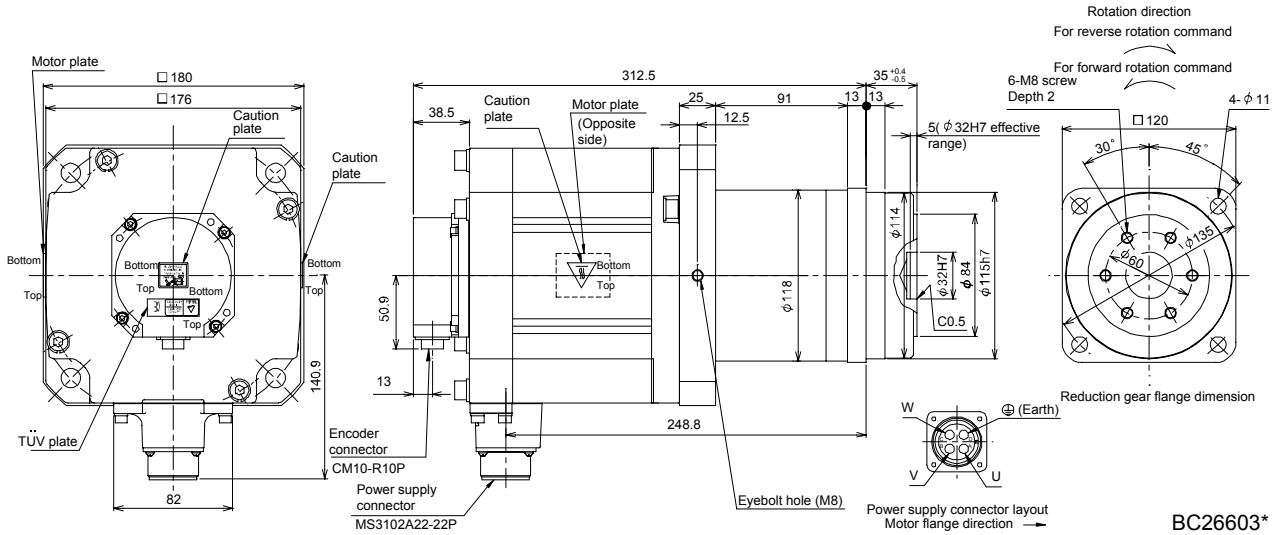

Model	Output [kW]	Reduction gear model	Reduction ratio (Actual reduction ratio)	Inertia moment $J [\times 10^{-4} \text{kg} \cdot \text{m}^2] (\text{WK}^2 [\text{oz} \cdot \text{in}^2])$	Mass [kg] ([lb])
HF-SP352G5 HF-SP3524G5	3.5	HPG-50A-11-FOBBDF-S	1/11	83.1 (454)	36.1 (79.6)
		HPG-50A-21-FOBBDF-S	1/21	81.4 (445)	

[Unit: mm]

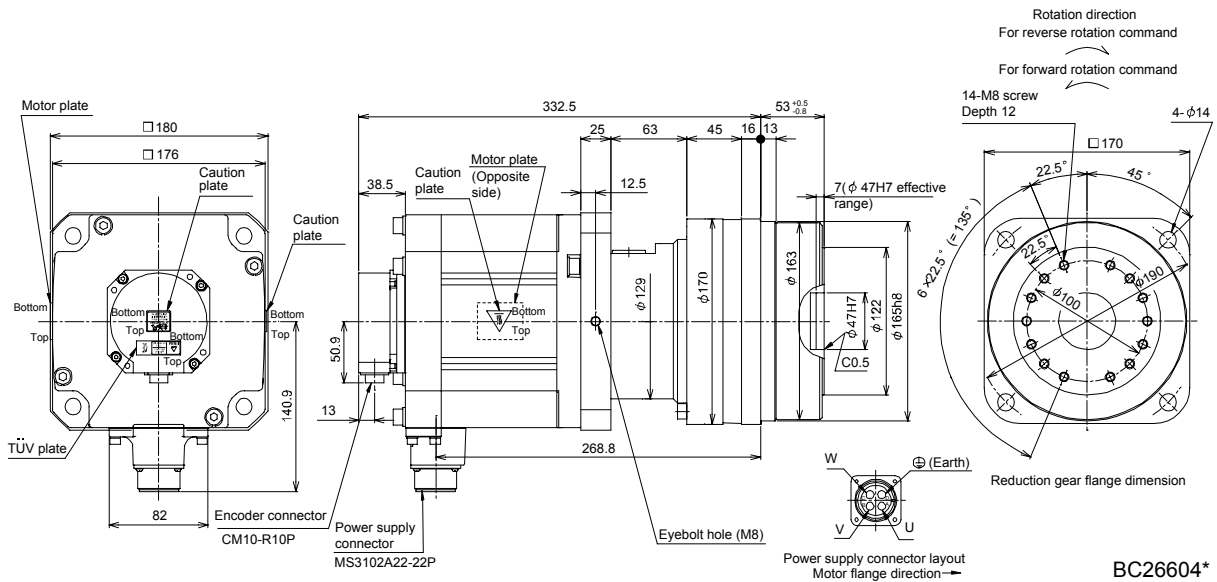

# 7. HF-SP SERIES

Model	Output [kW]	Reduction gear model	Reduction ratio (Actual reduction ratio)	Inertia moment $J [\times 10^{-4} \text{kg} \cdot \text{m}^2] (\text{WK}^2 [\text{oz} \cdot \text{in}^2])$	Mass [kg] ([lb])
HF-SP502G5	5.0	HPG-50A-05-FOBBCF-S	1/5	107.1 (586)	38.6 (85.1)
HF-SP5024G5		HPG-50A-11-FOBBDF-S	1/11	105.1 (575)	40.1 (88.4)

[Unit: mm]

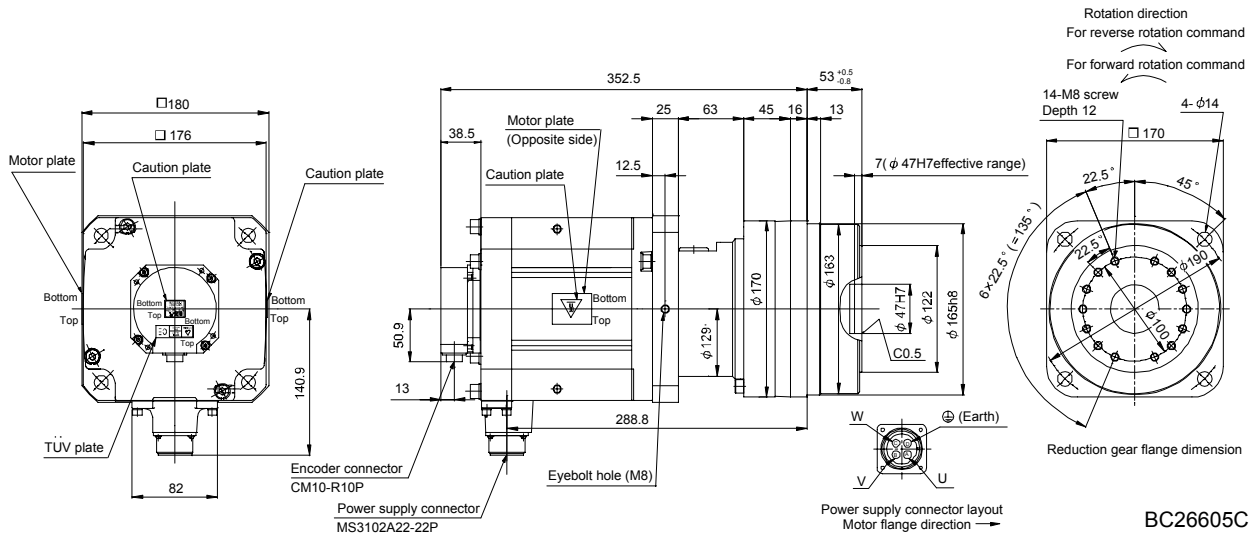

Model	Output [kW]	Reduction gear model	Reduction ratio (Actual reduction ratio)	Inertia moment $J [\times 10^{-4} \text{kg} \cdot \text{m}^2] (\text{WK}^2 [\text{oz} \cdot \text{in}^2])$	Mass [kg] ([lb])
HF-SP702G5	7.0	HPG-50A-05-FOBBCF-S	1/5	164.1 (897)	47.6 (105)
HF-SP7024G5					

[Unit: mm]

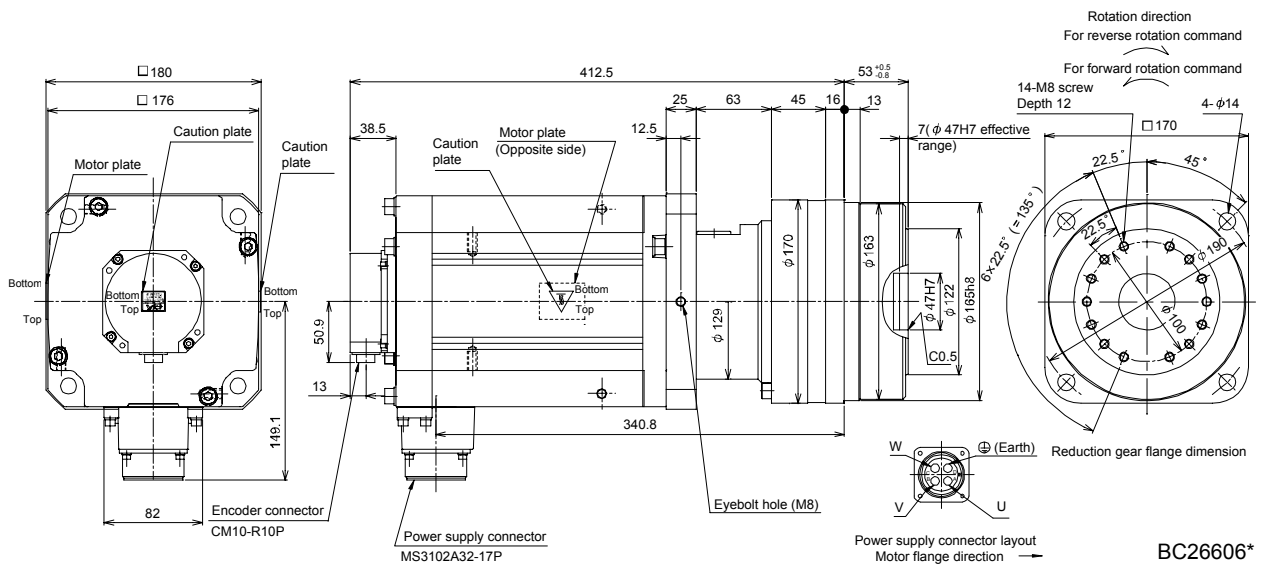

## 7. HF-SP SERIES

### 7.8.8 Flange-mounting flange output type for precision application compliant (with an electromagnetic brake)

Model	Output [kW]	Reduction gear model	Reduction ratio (Actual reduction ratio)	Brake static friction torque [N · m] (oz · in)	Inertia moment J [ $\times 10^{-4}$ kg · m <sup>2</sup> ] (WK <sup>2</sup> [oz · in <sup>2</sup> ])	Mass [kg] (lb)
HF-SP52BG5	0.5	HPG-20A-05-FOKSAWS-S	1/5	8.5 (1200)	8.95 (48.9)	9.5 (20.9)
HF-SP524BG5		HPG-20A-11-FOKSAXS-S	1/11		8.86 (48.4)	

[Unit: mm]

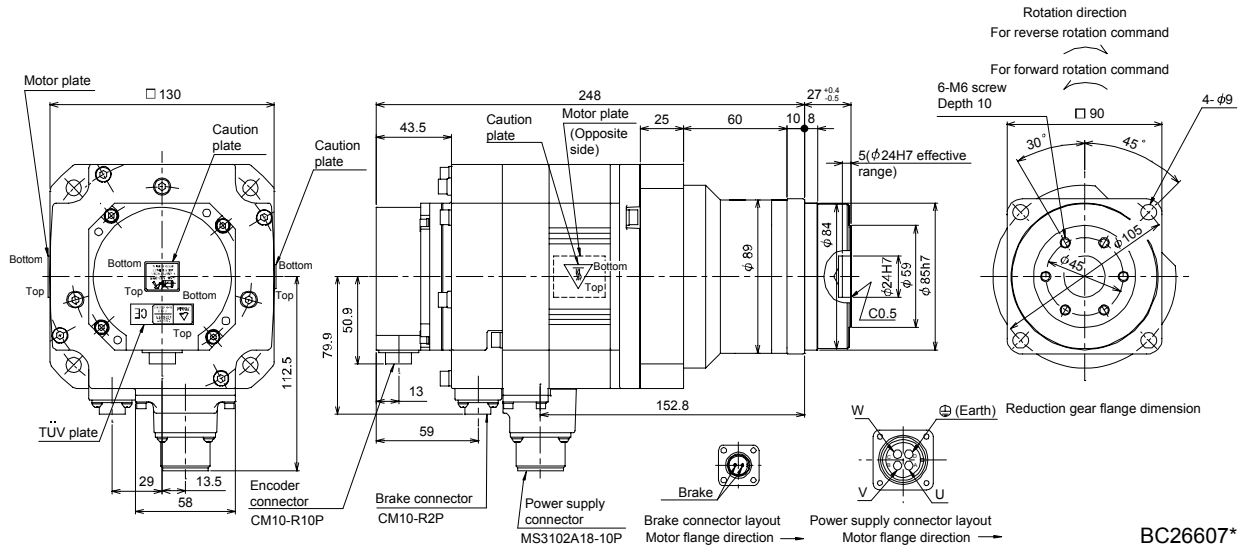

BC26607\*

Model	Output [kW]	Reduction gear model	Reduction ratio (Actual reduction ratio)	Brake static friction torque [N · m] (oz · in)	Inertia moment J [ $\times 10^{-4}$ kg · m <sup>2</sup> ] (WK <sup>2</sup> [oz · in <sup>2</sup> ])	Mass [kg] (lb)
HF-SP52BG5	0.5	HPG-32A-21-FOMCSYS-S	1/21	8.5 (1200)	11.2 (61.2)	13.2 (29.1)
HF-SP524BG5		HPG-32A-33-FOMCSZS-S	1/33		11.0 (60.1)	
		HPG-32A-45-FOMCSZS-S	1/45			

[Unit: mm]

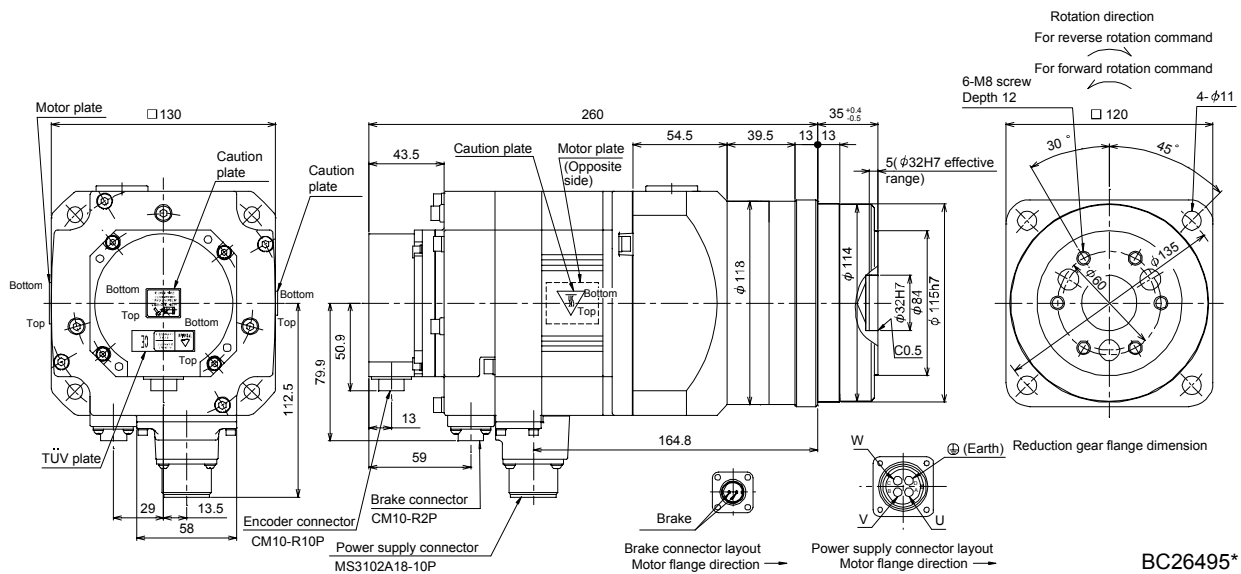

BC26495\*



# 7. HF-SP SERIES

Model	Output [kW]	Reduction gear model	Reduction ratio (Actual reduction ratio)	Brake static friction torque [N · m] ([oz · in])	Inertia moment J [ $\times 10^{-4}$ kg · m <sup>2</sup> ] (WK <sup>2</sup> [oz · in <sup>2</sup> ])	Mass [kg] ([lb])
HF-SP102BG5 HF-SP1024BG5	1.0	HPG-20A-05-FOKSAWS-S	1/5	8.5 (1200)	14.7 (80.4)	11.3 (24.9)

[Unit: mm]

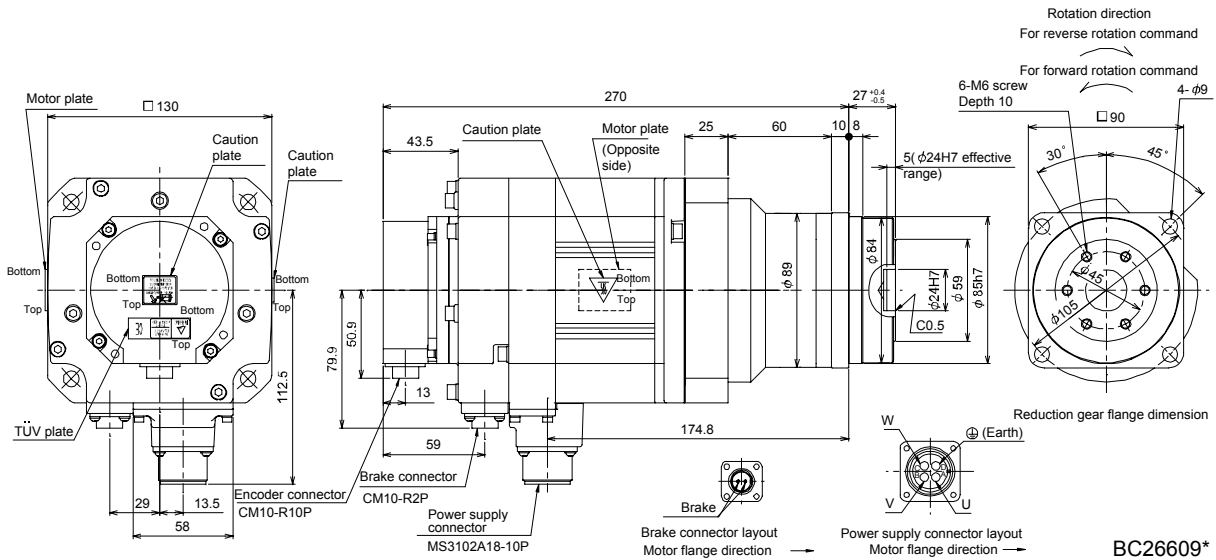

Model	Output [kW]	Reduction gear model	Reduction ratio (Actual reduction ratio)	Brake static friction torque [N · m] ([oz · in])	Inertia moment J [ $\times 10^{-4}$ kg · m <sup>2</sup> ] (WK <sup>2</sup> [oz · in <sup>2</sup> ])	Mass [kg] ([lb])
HF-SP102BG5	1.0	HPG-32A-11-FOMCSPS-S	1/11	8.5 (1200)	17.3 (94.6)	15.0 (33.1)
HF-SP1024BG5		HPG-32A-21-FOMCSYS-S	1/21		16.9 (92.4)	

[Unit: mm]

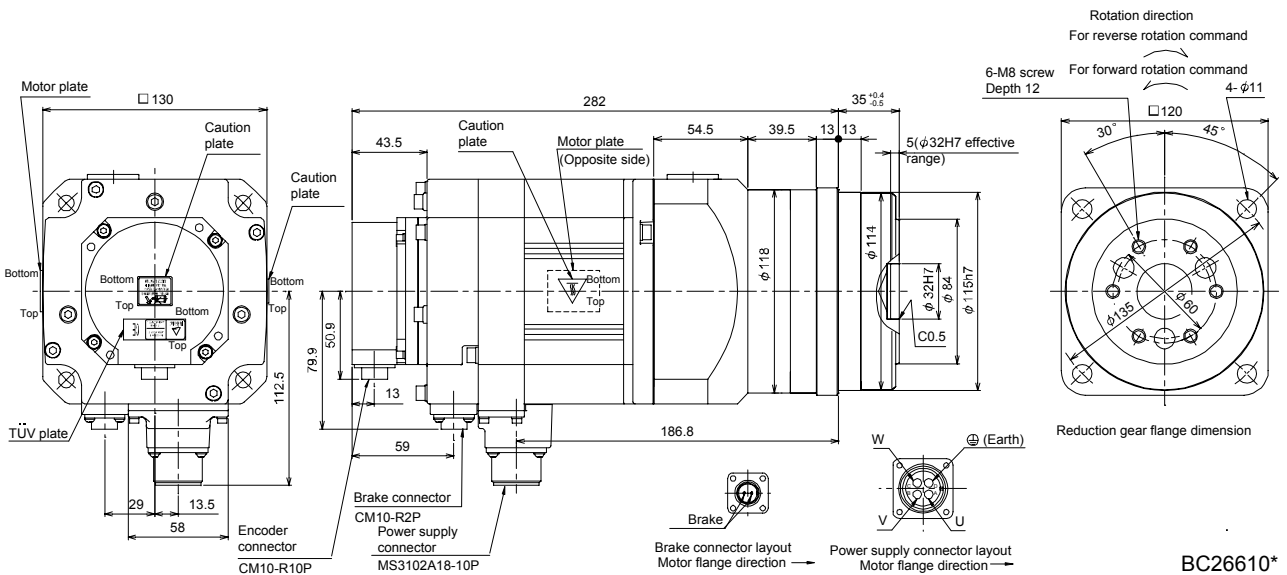

# 7. HF-SP SERIES

Model	Output [kW]	Reduction gear model	Reduction ratio (Actual reduction ratio)	Brake static friction torque [N · m] ([oz · in])	Inertia moment J [ $\times 10^{-4}$ kg · m <sup>2</sup> ] (WK <sup>2</sup> [oz · in <sup>2</sup> ])	Mass [kg] ([lb])
HF-SP102BG5	1.0	HPG-50A-33-FOAABC-S	1/33	8.5 (1200)	18.7 (102)	24.5 (54.0)
HF-SP1024BG5		HPG-50A-45-FOAABC-S	1/45		18.6 (102)	

[Unit: mm]

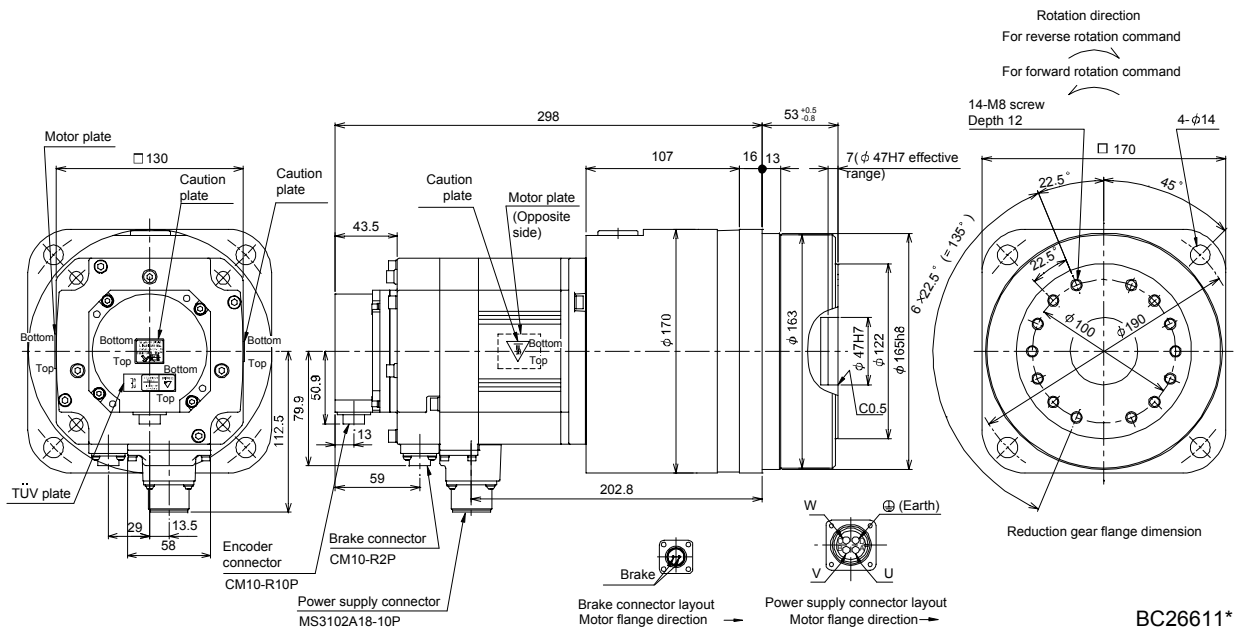

Model	Output [kW]	Reduction gear model	Reduction ratio (Actual reduction ratio)	Brake static friction torque [N · m] ([oz · in])	Inertia moment J [ $\times 10^{-4}$ kg · m <sup>2</sup> ] (WK <sup>2</sup> [oz · in <sup>2</sup> ])	Mass [kg] ([lb])
HF-SP152BG5	1.5	HPG-20A-05-FOKSAWS-S	1/5	8.5 (1200)	20.7 (113)	13.1 (28.9)
HF-SP1524BG5					20.7 (113)	

[Unit: mm]

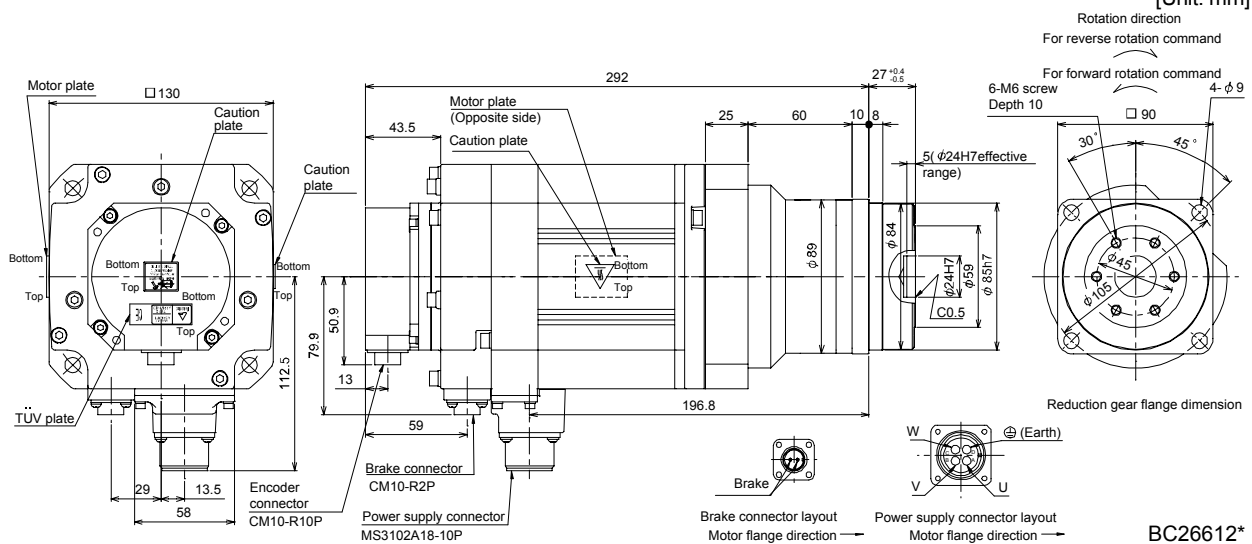

# 7. HF-SP SERIES

Model	Output [kW]	Reduction gear model	Reduction ratio (Actual reduction ratio)	Brake static friction torque [N · m] ([oz · in])	Inertia moment J [ $\times 10^{-4} \text{kg} \cdot \text{m}^2$ ] ( $\text{WK}^2$ [oz · in <sup>2</sup> ])	Mass [kg] ([lb])
HF-SP152BG5 HF-SP1524BG5	1.5	HPG-32A-11-FOMCSPS-S	1/11	8.5 (1200)	23.3 (127)	16.8 (37.0)

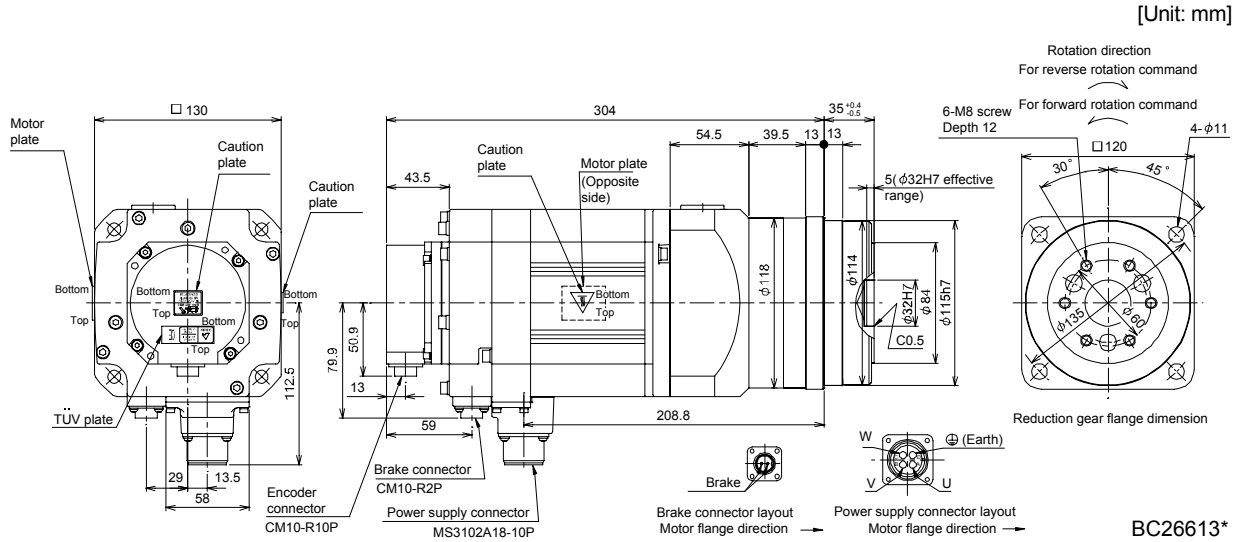

Model	Output [kW]	Reduction gear model	Reduction ratio (Actual reduction ratio)	Brake static friction torque [N · m] ([oz · in])	Inertia moment J [ $\times 10^{-4} \text{kg} \cdot \text{m}^2$ ] ( $\text{WK}^2$ [oz · in <sup>2</sup> ])	Mass [kg] ([lb])
HF-SP152BG5 HF-SP1524BG5	1.5	HPG-50A-21-FOAABC-S	1/21	8.5 (1200)	25.7 (141)	26.3 (58.0)
		HPG-50A-33-FOAABC-S	1/33		24.7 (135)	
		HPG-50A-45-FOAABC-S	1/45		24.6 (134)	

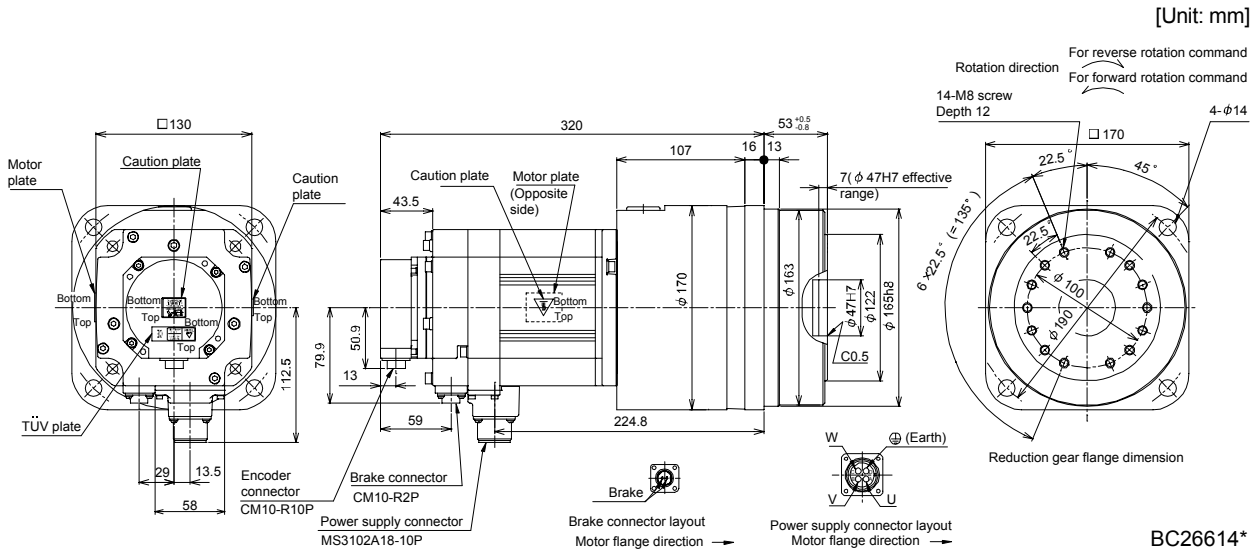

# 7. HF-SP SERIES

Model	Output [kW]	Reduction gear model	Reduction ratio (Actual reduction ratio)	Brake static friction torque [N · m] (oz · in)	Inertia moment J [ $\times 10^{-4} \text{kg} \cdot \text{m}^2$ ] ( $\text{WK}^2 \text{oz} \cdot \text{in}^2$ )	Mass [kg] (lb)
HF-SP202BG5	2.0	HPG-32A-05-FOPBZI-S	1/5	44 (6230)	52.5 (287)	25.5 (56.2)
HF-SP2024BG5		HPG-32A-11-FOPBZJ-S	1/11		52.3 (286)	

[Unit: mm]

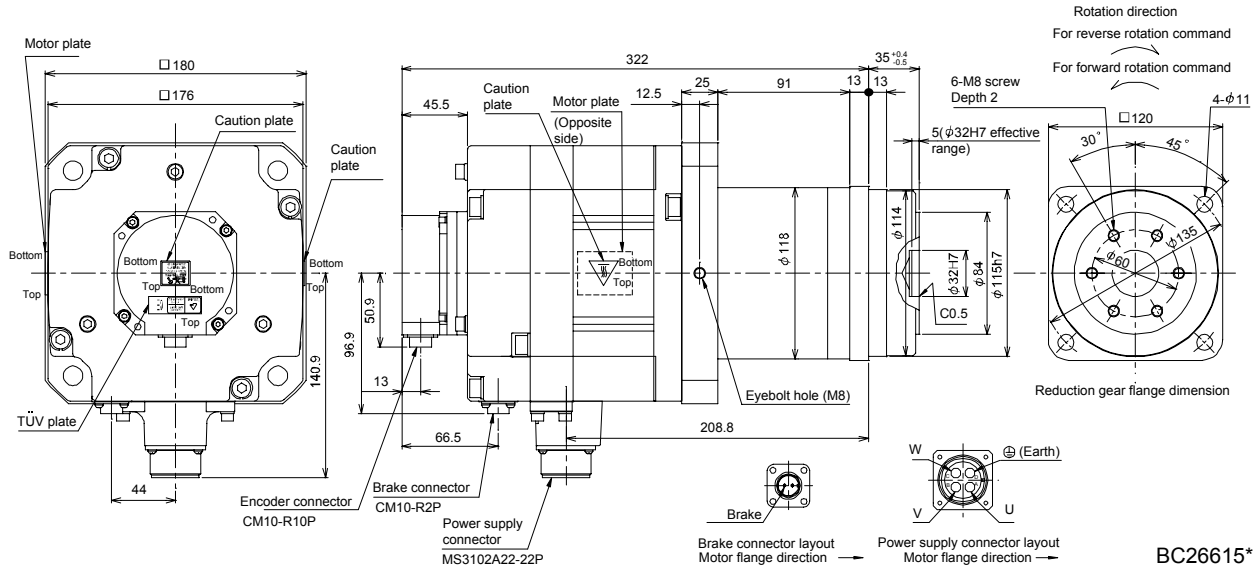

BC26615\*

Model	Output [kW]	Reduction gear model	Reduction ratio (Actual reduction ratio)	Brake static friction torque [N · m] (oz · in)	Inertia moment J [ $\times 10^{-4} \text{kg} \cdot \text{m}^2$ ] ( $\text{WK}^2 \text{oz} \cdot \text{in}^2$ )	Mass [kg] (lb)
HF-SP202BG5	2.0	HPG-50A-21-FOBBDP-S	1/21	44 (6230)	54.3 (297)	35.1 (77.4)
HF-SP2024BG5		HPG-50A-33-FOBBDP-S	1/33		53.3 (291)	
		HPG-50A-45-FOBBDP-S	1/45			

[Unit: mm]

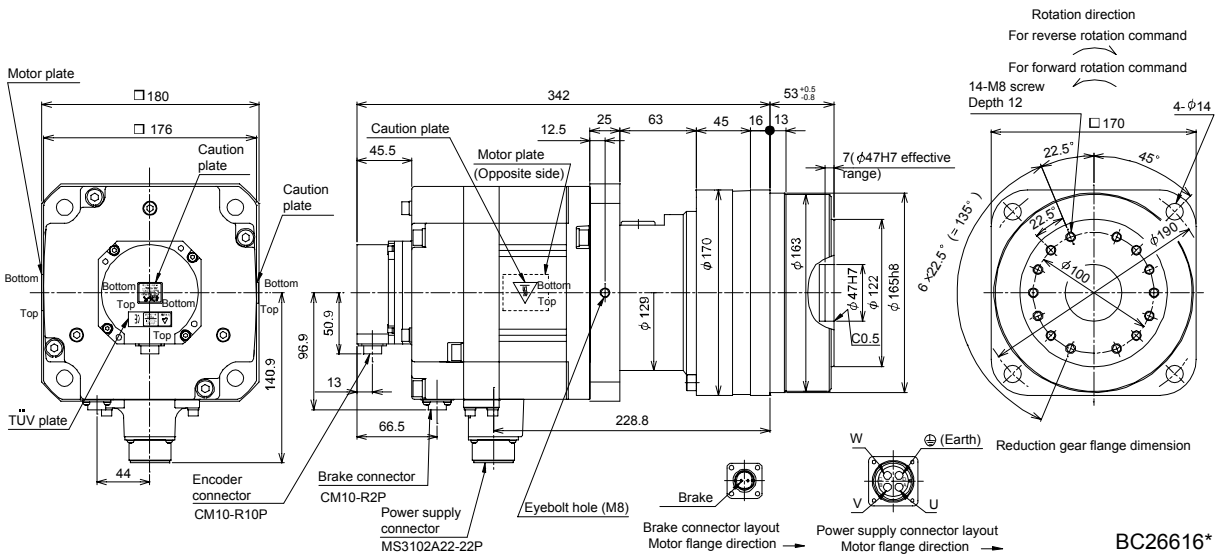

BC26616\*

# 7. HF-SP SERIES

Model	Output [kW]	Reduction gear model	Reduction ratio (Actual reduction ratio)	Brake static friction torque [N · m] ([oz · in])	Inertia moment J [ $\times 10^{-4} \text{kg} \cdot \text{m}^2$ ] ( $\text{WK}^2$ [oz · in <sup>2</sup> ])	Mass [kg] ([lb])
HF-SP352BG5 HF-SP3524BG5	3.5	HPG-32A-05-FOPBZI-S	1/5	44 (6230)	89.3 (488)	32.5 (71.7)

[Unit: mm]

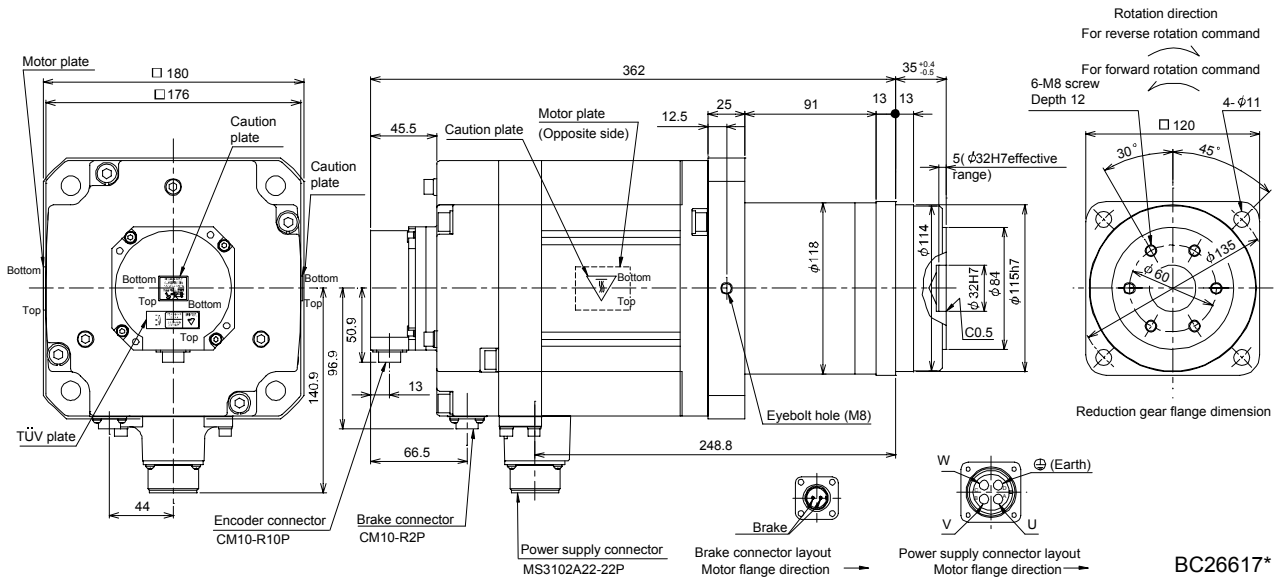

BC26617\*

Model	Output [kW]	Reduction gear model	Reduction ratio (Actual reduction ratio)	Brake static friction torque [N · m] ([oz · in])	Inertia moment J [ $\times 10^{-4} \text{kg} \cdot \text{m}^2$ ] ( $\text{WK}^2$ [oz · in <sup>2</sup> ])	Mass [kg] ([lb])
HF-SP352BG5 HF-SP3524BG5	3.5	HPG-50A-11-FOBBDF-S	1/11	44 (6230)	92.8 (507)	42.1 (92.8)
		HPG-50A-21-FOBBDF-S	1/21		91.1 (498)	

[Unit: mm]

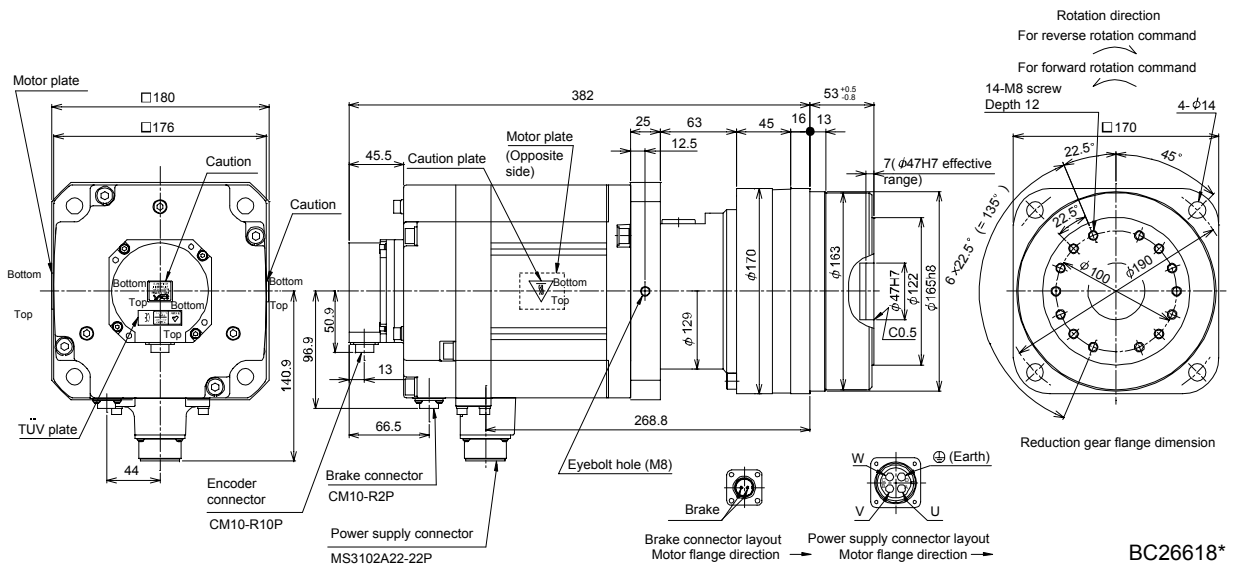

BC26618\*

# 7. HF-SP SERIES

Model	Output [kW]	Reduction gear model	Reduction ratio (Actual reduction ratio)	Brake static friction torque [N · m] (oz · in)	Inertia moment J [ $\times 10^{-4} \text{kg} \cdot \text{m}^2$ ] ( $\text{WK}^2$ [oz · in <sup>2</sup> ])	Mass [kg] (lb)
HF-SP502BG5	5.0	HPG-50A-05-FOBBCF-S	1/5	44 (6230)	117.1 (640)	44.6 (98.3)
HF-SP5024BG5		HPG-50A-11-FOBBDF-S	1/11		115.1 (629)	46.1(102)

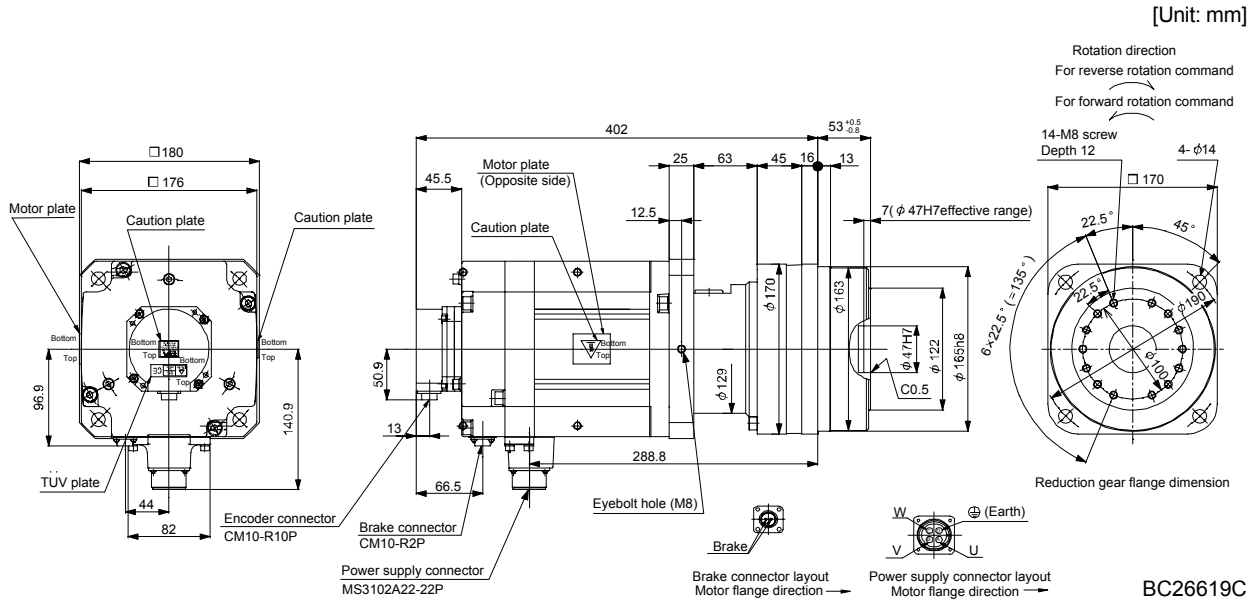

Model	Output [kW]	Reduction gear model	Reduction ratio (Actual reduction ratio)	Brake static friction torque [N · m] (oz · in)	Inertia moment J [ $\times 10^{-4} \text{kg} \cdot \text{m}^2$ ] ( $\text{WK}^2$ [oz · in <sup>2</sup> ])	Mass [kg] (lb)
HF-SP702BG5	7.0	HPG-50A-05-FOBBCF-S	1/5	44 (6230)	174.1 (952)	53.6 (118)
HF-SP7024BG5					174.1 (952)	53.6 (118)

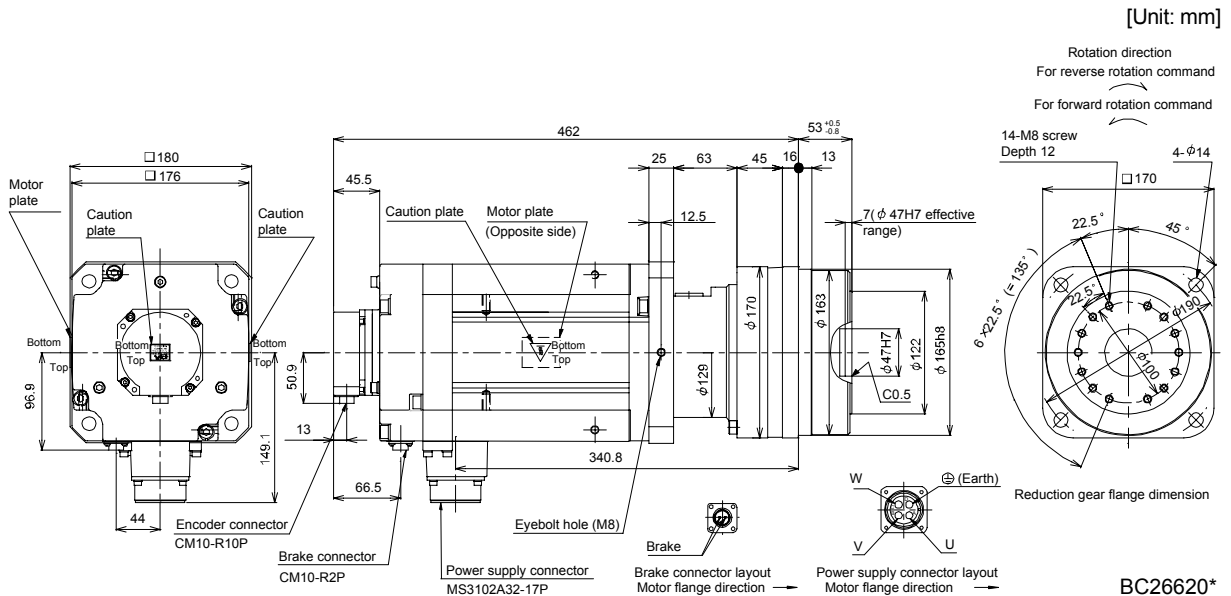

## 7. HF-SP SERIES

### 7.8.9 Flange-mounting shaft output type for precision application compliant (without an electromagnetic brake)

Model	Output [kW]	Reduction gear model	Reduction ratio (Actual reduction ratio)	Inertia moment $J [\times 10^{-4} \text{kg} \cdot \text{m}^2] (\text{WK}^2 [\text{oz} \cdot \text{in}^2])$	Mass [kg] ([lb])
HF-SP52G7	0.5	HPG-20A-05-J2KSAWS-S	1/5	6.79 (37.1)	8.0 (17.6)
HF-SP524G7		HPG-20A-11-J2KSAXS-S	1/11	6.66 (36.4)	8.2 (18.1)

[Unit: mm]

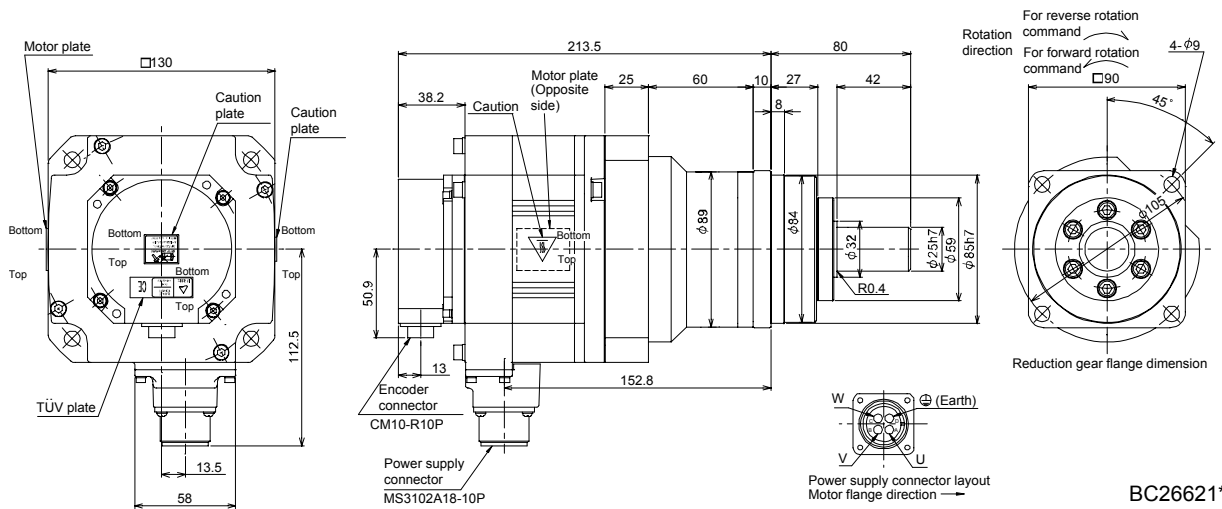

Model	Output [kW]	Reduction gear model	Reduction ratio (Actual reduction ratio)	Inertia moment $J [\times 10^{-4} \text{kg} \cdot \text{m}^2] (\text{WK}^2 [\text{oz} \cdot \text{in}^2])$	Mass [kg] ([lb])
HF-SP52G7	0.5	HPG-32A-21-J2MCSYS-S	1/21	9.00 (49.2)	12.7 (28.0)
HF-SP524G7		HPG-32A-33-J2MCSZS-S	1/33	8.80 (48.1)	
		HPG-32A-45-J2MCSZS-S	1/45		

[Unit: mm]

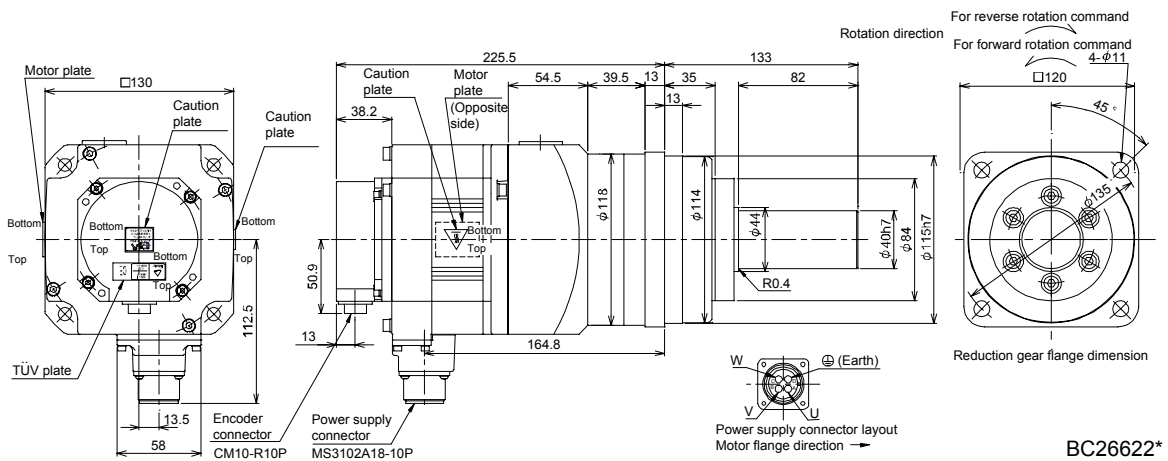

# 7. HF-SP SERIES

Model	Output [kW]	Reduction gear model	Reduction ratio (Actual reduction ratio)	Inertia moment $J$ [ $\times 10^{-4} \text{kg} \cdot \text{m}^2$ ] ( $\text{WK}^2$ [oz · in <sup>2</sup> ])	Mass [kg] ([lb])
HF-SP102G7 HF-SP1024G7	1.0	HPG-20A-05-J2KSAWS-S	1/5	12.6 (68.9)	9.7 (21.4)

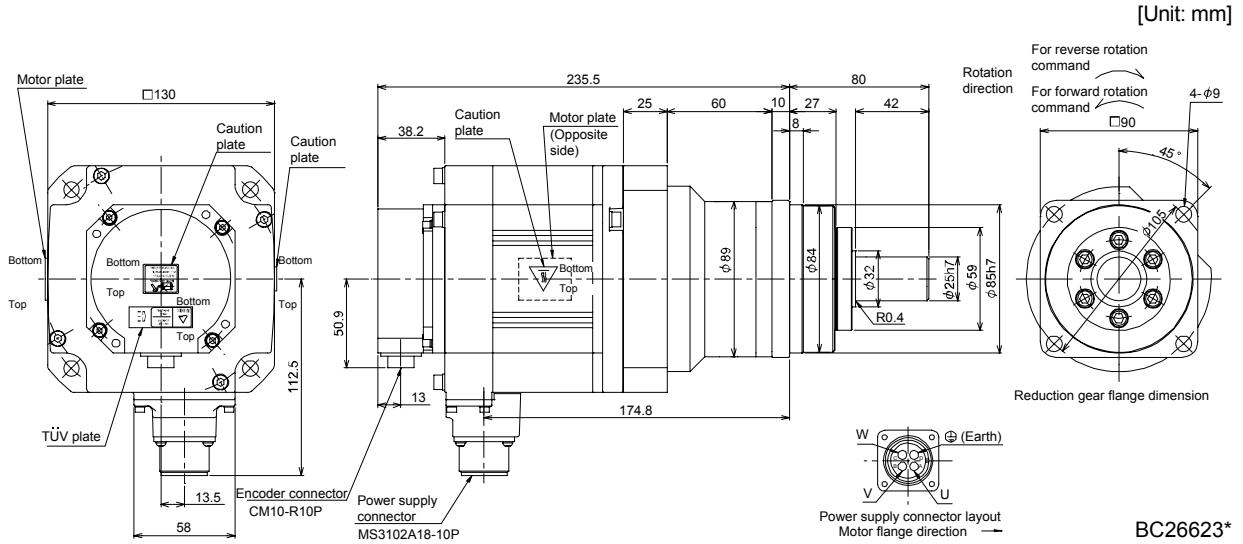

Model	Output [kW]	Reduction gear model	Reduction ratio (Actual reduction ratio)	Inertia moment $J$ [ $\times 10^{-4} \text{kg} \cdot \text{m}^2$ ] ( $\text{WK}^2$ [oz · in <sup>2</sup> ])	Mass [kg] ([lb])
HF-SP102G7	1.0	HPG-32A-11-J2MCSPS-S	1/11	15.3 (83.7)	14.4 (31.7)
HF-SP1024G7		HPG-32A-21-J2MCSYS-S	1/21	14.8 (80.9)	

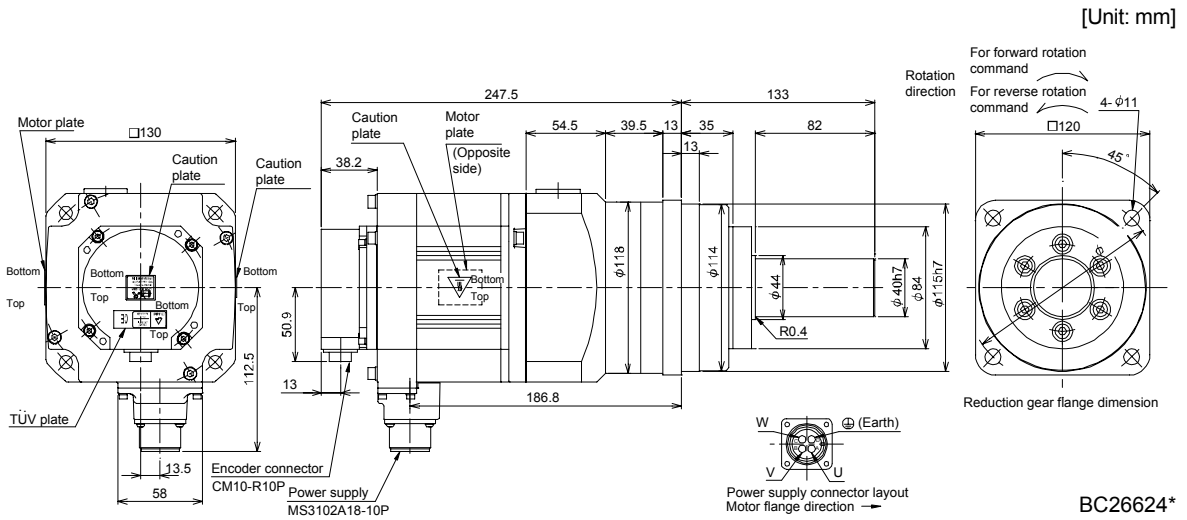



## 7. HF-SP SERIES

Model	Output [kW]	Reduction gear model	Reduction ratio (Actual reduction ratio)	Inertia moment $J$ [ $\times 10^{-4}$ kg · m <sup>2</sup> ] (WK <sup>2</sup> [oz · in <sup>2</sup> ])	Mass [kg] ([lb])
HF-SP102G7	1.0	HPG-50A-33-J2AABC-S	1/33	16.6 (90.8)	25.5 (56.2)
HF-SP1024G7		HPG-50A-45-J2AABC-S	1/45		

[Unit: mm]

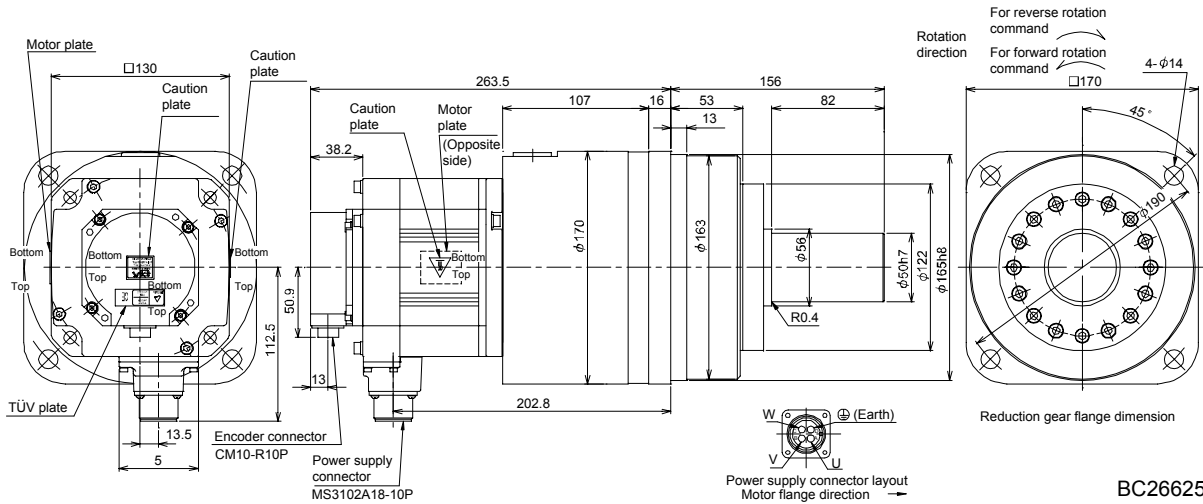

Model	Output [kW]	Reduction gear model	Reduction ratio (Actual reduction ratio)	Inertia moment $J$ [ $\times 10^{-4}$ kg · m <sup>2</sup> ] (WK <sup>2</sup> [oz · in <sup>2</sup> ])	Mass [kg] ([lb])
HF-SP152G7	1.5	HPG-20A-05-J2KSAWS-S	1/5	18.5 (101)	11.5 (25.4)
HF-SP1524G7					

[Unit: mm]

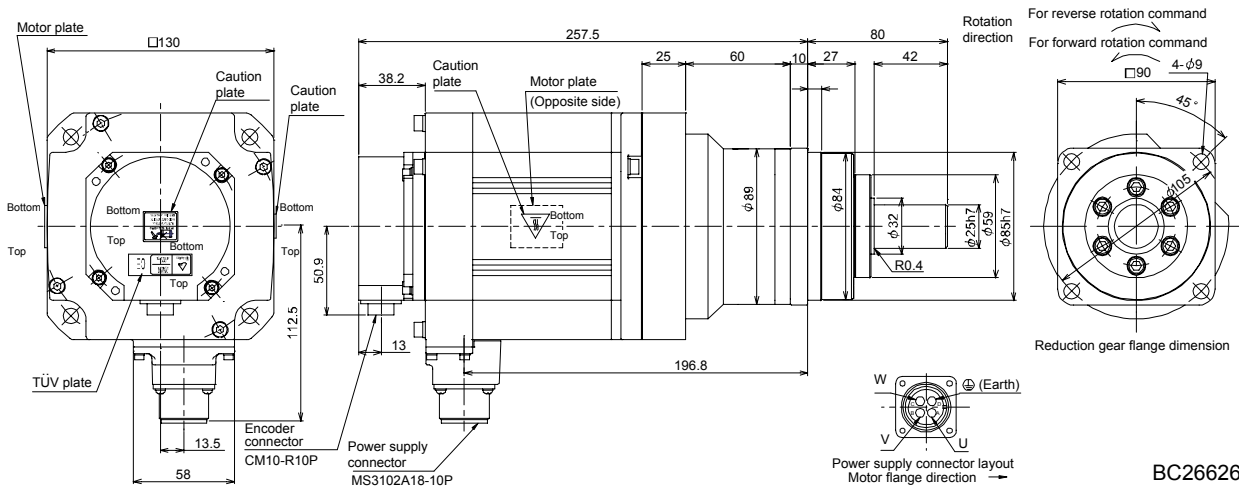

# 7. HF-SP SERIES

Model	Output [kW]	Reduction gear model	Reduction ratio (Actual reduction ratio)	Inertia moment $J [\times 10^{-4} \text{kg} \cdot \text{m}^2] (\text{WK}^2 [\text{oz} \cdot \text{in}^2])$	Mass [kg] ([lb])
HF-SP152G7 HF-SP1524G7	1.5	HPG-32A-11-J2MCSPS-S	1/11	21.2 (116)	16.2 (35.7)

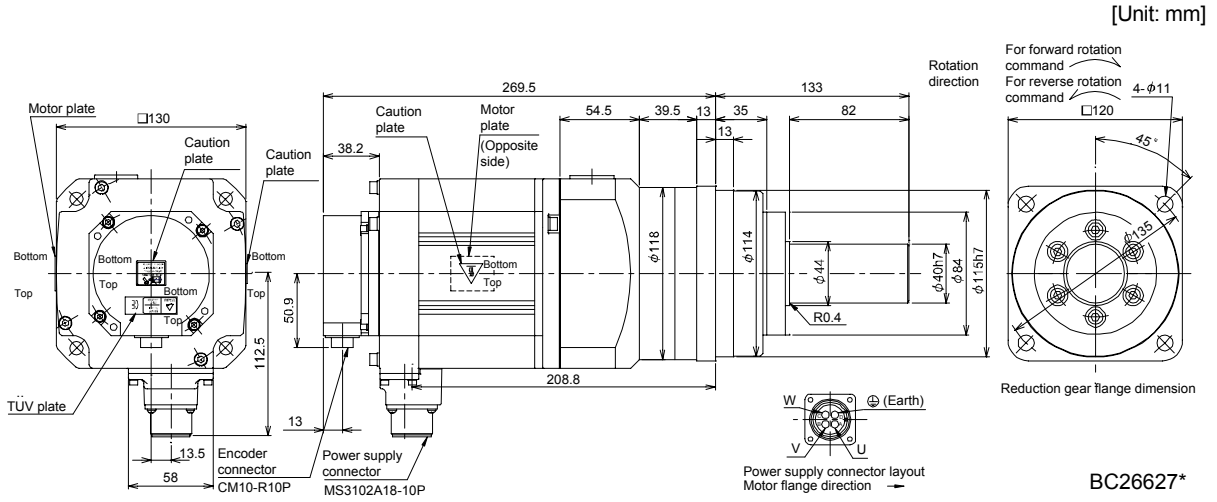

Model	Output [kW]	Reduction gear model	Reduction ratio (Actual reduction ratio)	Inertia moment $J [\times 10^{-4} \text{kg} \cdot \text{m}^2] (\text{WK}^2 [\text{oz} \cdot \text{in}^2])$	Mass [kg] ([lb])
HF-SP152G7 HF-SP1524G7	1.5	HPG-50A-21-J2AABC-S	1/21	23.5 (128)	27.3 (60.2)
		HPG-50A-33-J2AABC-S	1/33	22.5 (123)	
		HPG-50A-45-J2AABC-S	1/45	22.5 (123)	

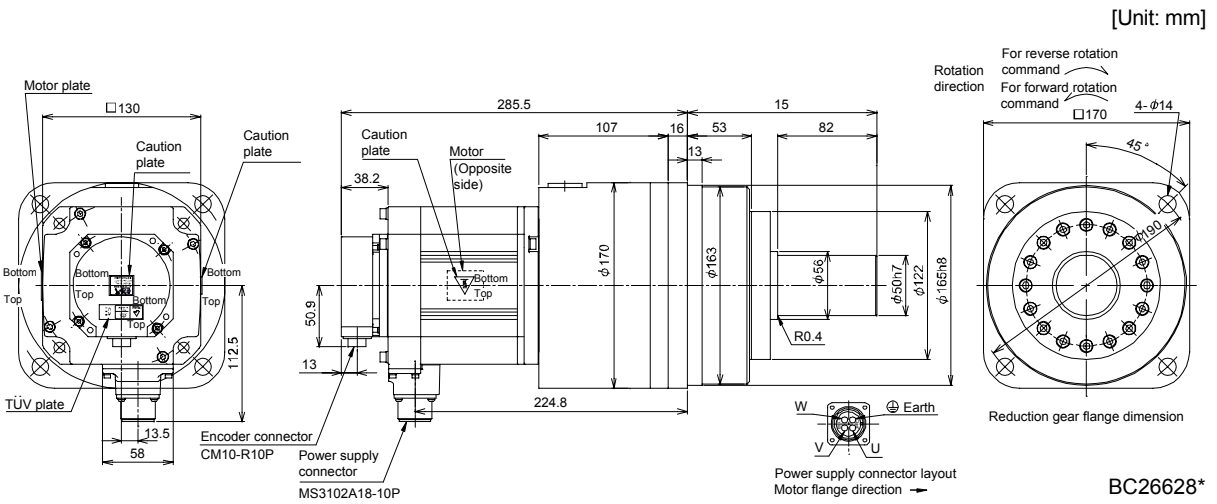

# 7. HF-SP SERIES

Model	Output [kW]	Reduction gear model	Reduction ratio (Actual reduction ratio)	Inertia moment J [ $\times 10^{-4} \text{kg} \cdot \text{m}^2$ ] (WK <sup>2</sup> [oz · in <sup>2</sup> ])	Mass [kg] ([lb])
HF-SP202G7	2.0	HPG-32A-05-J2PBZI-S	1/5	43.2 (236)	20.9 (46.1)
HF-SP2024G7		HPG-32A-11-J2PBZJ-S	1/11	42.8 (234)	21.4 (47.2)

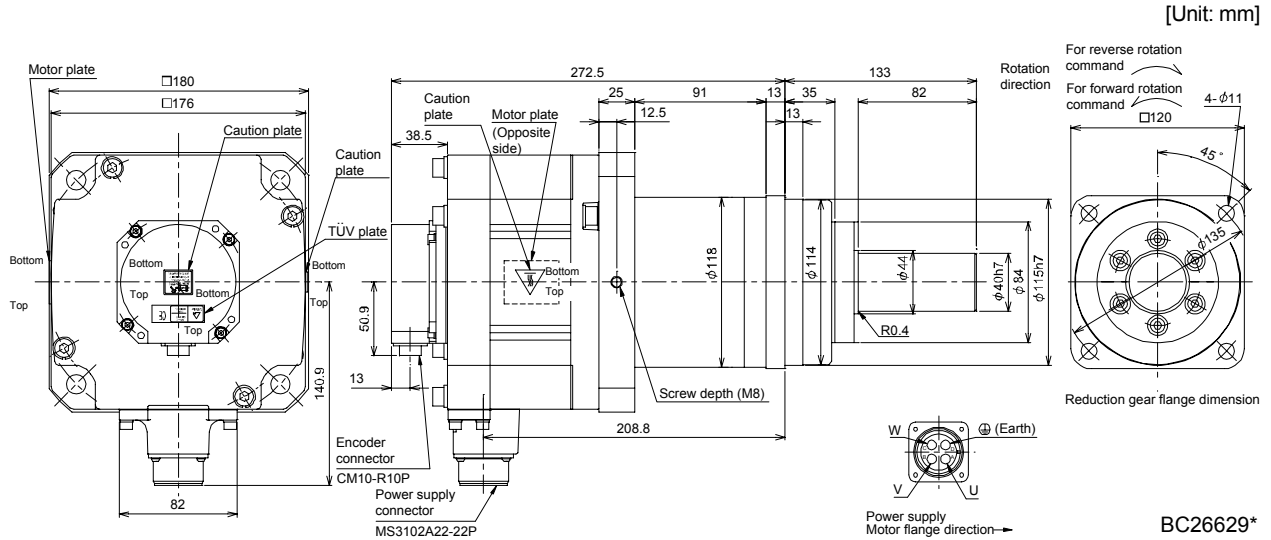

Model	Output [kW]	Reduction gear model	Reduction ratio (Actual reduction ratio)	Inertia moment J [ $\times 10^{-4} \text{kg} \cdot \text{m}^2$ ] (WK <sup>2</sup> [oz · in <sup>2</sup> ])	Mass [kg] ([lb])
HF-SP202G7	2.0	HPG-50A-21-J2BBDF-S	1/21	44.8 (245)	32.1 (70.8)
HF-SP2024G7		HPG-50A-33-J2BBDF-S	1/33	43.7 (239)	
		HPG-50A-45-J2BBDF-S	1/45		

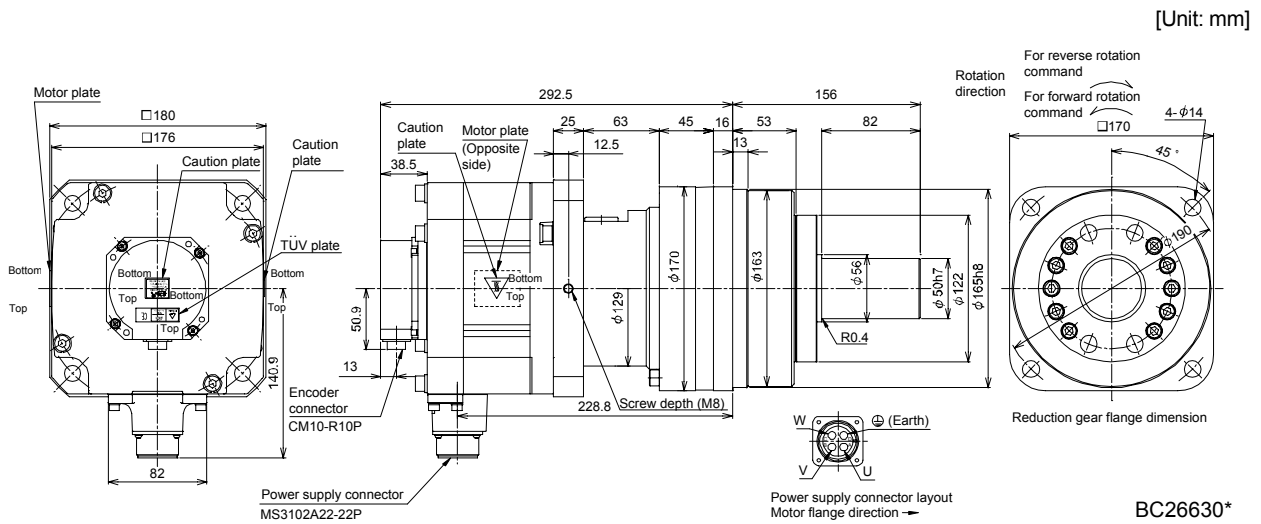

# 7. HF-SP SERIES

Model	Output [kW]	Reduction gear model	Reduction ratio (Actual reduction ratio)	Inertia moment $J [\times 10^{-4} \text{kg} \cdot \text{m}^2] (\text{WK}^2 [\text{oz} \cdot \text{in}^2])$	Mass [kg] ([lb])
HF-SP352G7 HF-SP3524G7	3.5	HPG-32A-05-J2PBZI-S	1/5	79.9 (437)	27.9 (61.5)

[Unit: mm]

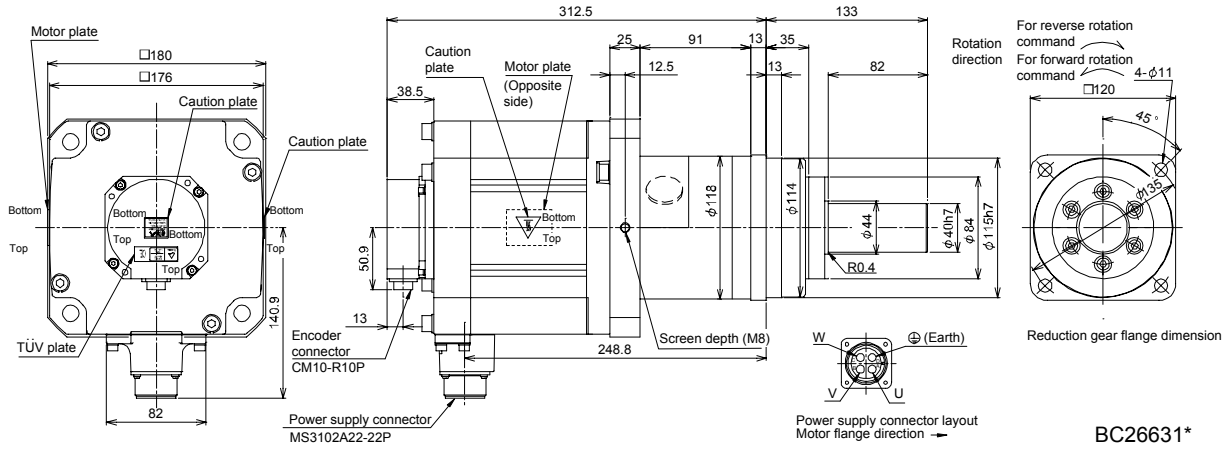

BC26631\*

Model	Output [kW]	Reduction gear model	Reduction ratio (Actual reduction ratio)	Inertia moment $J [\times 10^{-4} \text{kg} \cdot \text{m}^2] (\text{WK}^2 [\text{oz} \cdot \text{in}^2])$	Mass [kg] ([lb])
HF-SP352G7	3.5	HPG-50A-11-J2BBDF-S	1/11	83.4 (456)	39.1 (86.2)
HF-SP3524G7		HPG-50A-21-J2BBDF-S	1/21	81.5 (446)	

[Unit: mm]

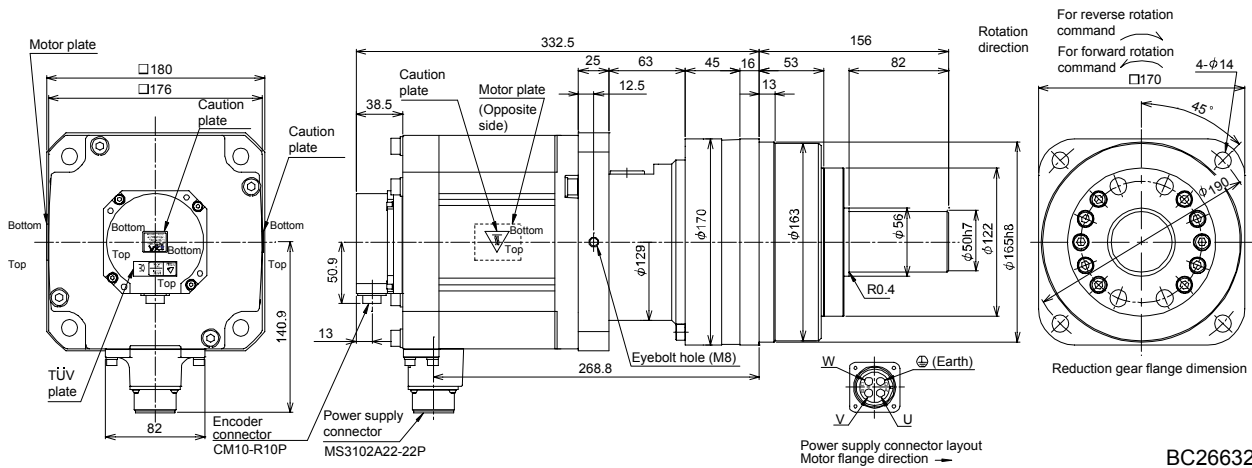

BC26632\*

# 7. HF-SP SERIES

Model	Output [kW]	Reduction gear model	Reduction ratio (Actual reduction ratio)	Inertia moment $J [\times 10^{-4} \text{kg} \cdot \text{m}^2] (\text{WK}^2 [\text{oz} \cdot \text{in}^2])$	Mass [kg] ([lb])
HF-SP502G7	5.0	HPG-50A-05-J2BBCF-S	1/5	108.5 (593)	41.6 (91.7)
HF-SP5024G7		HPG-50A-11-J2BBDF-S	1/11	105.4 (576)	43.1 (95.0)

[Unit: mm]

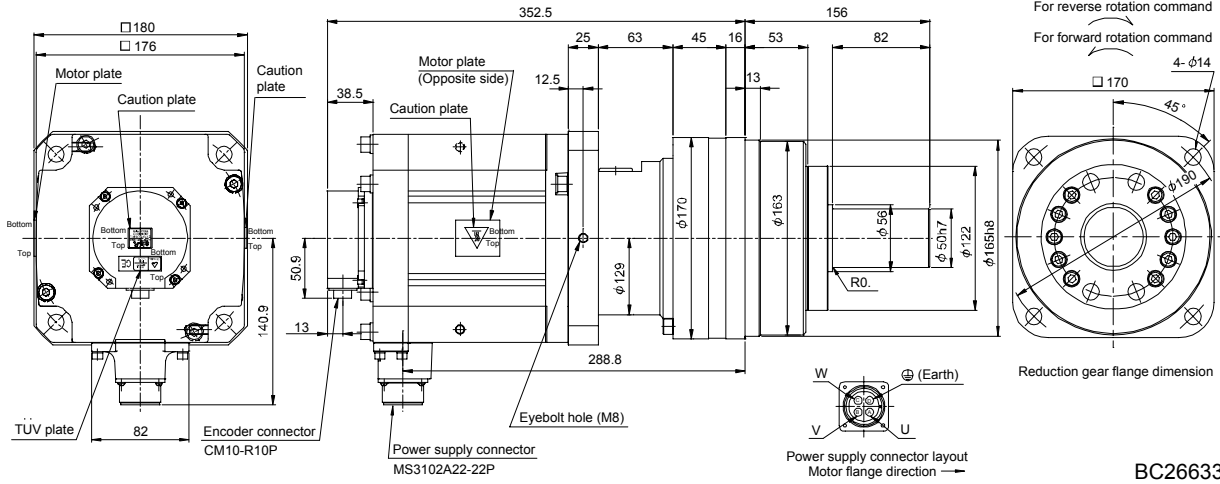

BC26633C

Model	Output [kW]	Reduction gear model	Reduction ratio (Actual reduction ratio)	Inertia moment $J [\times 10^{-4} \text{kg} \cdot \text{m}^2] (\text{WK}^2 [\text{oz} \cdot \text{in}^2])$	Mass [kg] ([lb])
HF-SP702G7	7.0	HPG-50A-05-J2BBCF-S	1/5	165.5 (905)	50.6 (112)
HF-SP7024G7					

[Unit: mm]

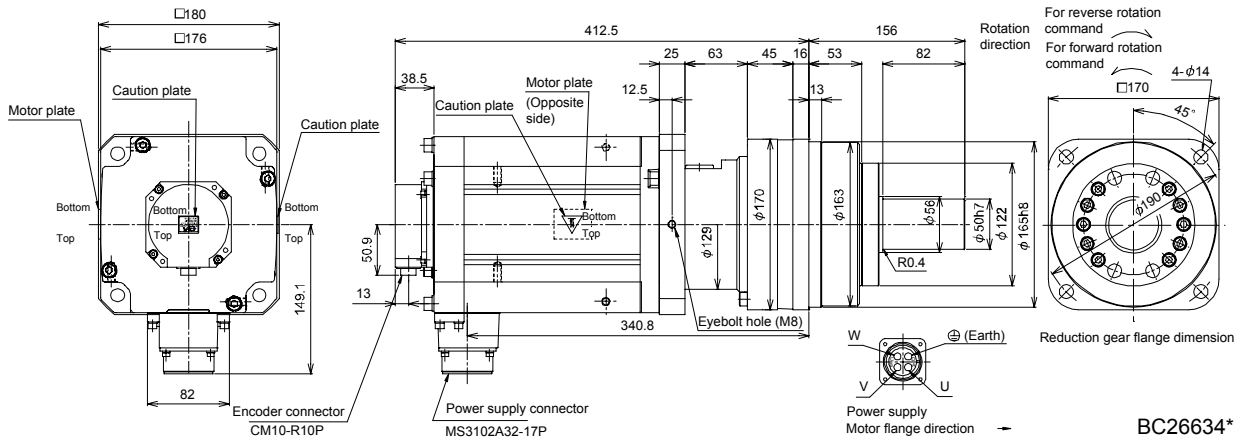

BC26634\*

## 7. HF-SP SERIES

### 7.8.10 Flange-mounting shaft output type for precision application compliant (with an electromagnetic brake)

Model	Output [kW]	Reduction gear model	Reduction ratio (Actual reduction ratio)	Brake static friction torque [N · m] (oz · in)	Inertia moment J [ $\times 10^{-4}$ kg · m <sup>2</sup> ] (WK <sup>2</sup> [oz · in <sup>2</sup> ])	Mass [kg] (lb)
HF-SP52BG7	0.5	HPG-20A-05-J2KSAWS-S	1/5	8.5 (1200)	8.99 (49.2)	9.9 (21.8)
HF-SP524BG7		HPG-20A-11-J2KSAXS-S	1/11		8.86 (48.4)	

[Unit: mm]

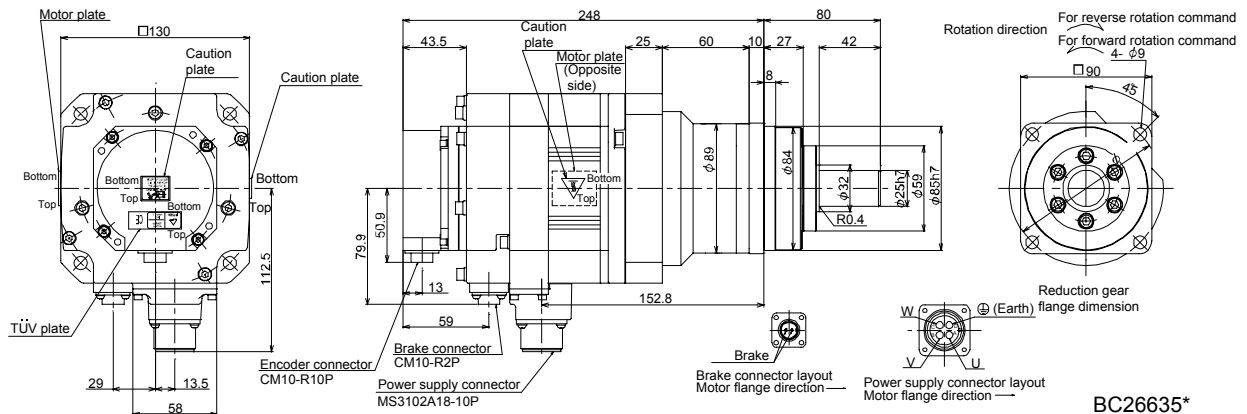

Model	Output [kW]	Reduction gear model	Reduction ratio (Actual reduction ratio)	Brake static friction torque [N · m] (oz · in)	Inertia moment J [ $\times 10^{-4}$ kg · m <sup>2</sup> ] (WK <sup>2</sup> [oz · in <sup>2</sup> ])	Mass [kg] (lb)
HF-SP52BG7	0.5	HPG-32A-21-J2MCSYS-S	1/21	8.5 (1200)	11.2 (61.2)	14.6 (32.2)
HF-SP524BG7		HPG-32A-33-J2MCSZS-S	1/33		11.0 (60.1)	
		HPG-32A-45-J2MCSZS-S	1/45			

[Unit: mm]

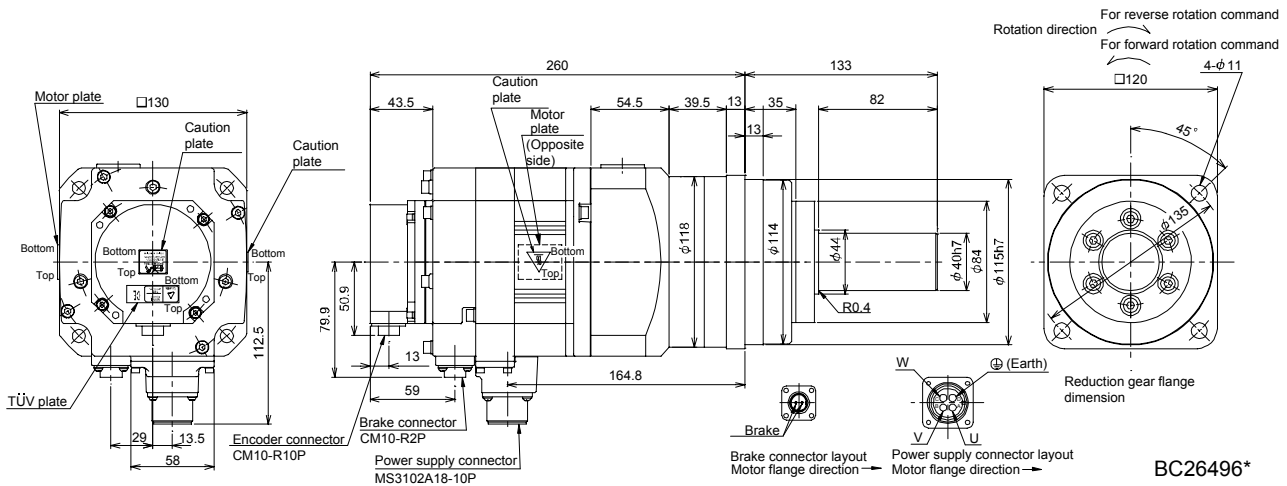

## 7. HF-SP SERIES

Model	Output [kW]	Reduction gear model	Reduction ratio (Actual reduction ratio)	Brake static friction torque [N · m] (oz · in)	Inertia moment J [ $\times 10^{-4}$ kg · m <sup>2</sup> ] (WK <sup>2</sup> [oz · in <sup>2</sup> ])	Mass [kg] (lb)
HF-SP102BG7 HF-SP1024BG7	1.0	HPG-20A-05-J2KSAWS-S	1/5	8.5 (1200)	14.7 (80.4)	11.7 (25.8)

[Unit: mm]

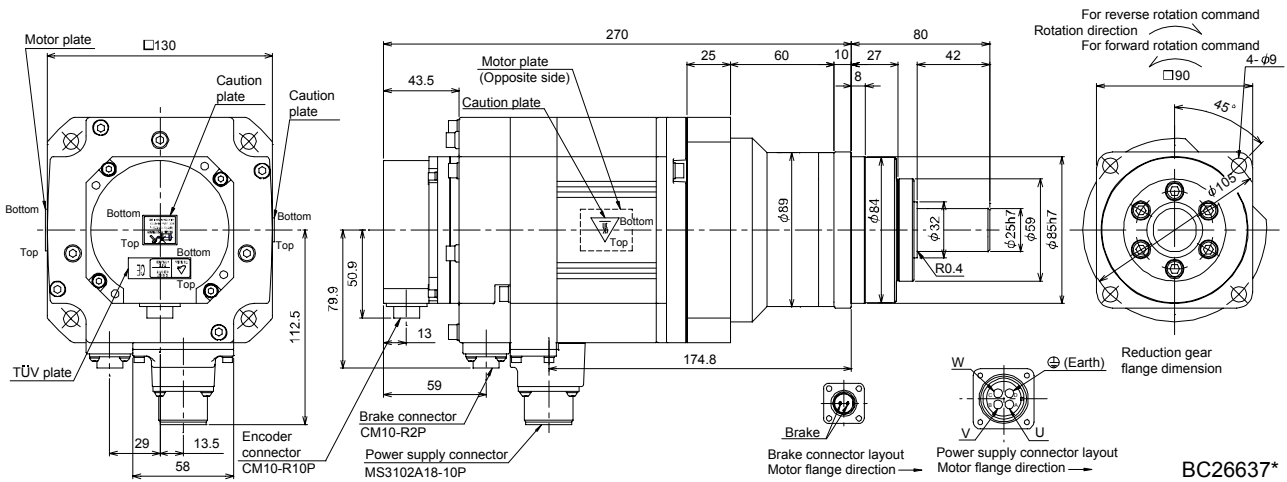

Model	Output [kW]	Reduction gear model	Reduction ratio (Actual reduction ratio)	Brake static friction torque [N · m] (oz · in)	Inertia moment J [ $\times 10^{-4}$ kg · m <sup>2</sup> ] (WK <sup>2</sup> [oz · in <sup>2</sup> ])	Mass [kg] (lb)
HF-SP102BG7	1.0	HPG-32A-11-J2MCSPS-S	1/11	8.5 (1200)	17.4 (95.1)	16.4 (36.2)
HF-SP1024BG7		HPG-32A-21-J2MCSYS-S	1/21		16.9 (92.4)	

[Unit: mm]

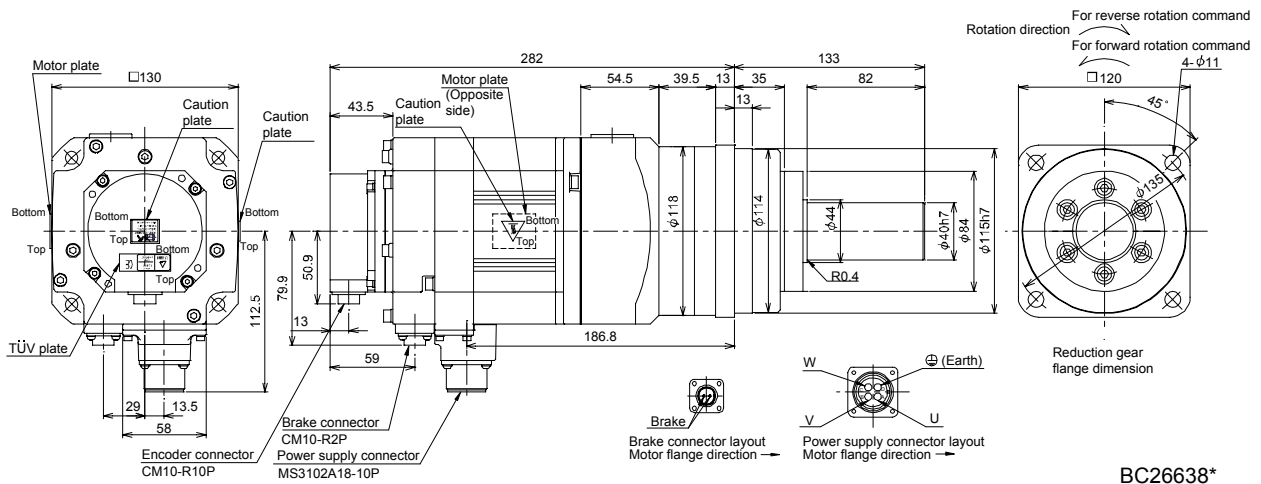

## 7. HF-SP SERIES

Model	Output [kW]	Reduction gear model	Reduction ratio (Actual reduction ratio)	Brake static friction torque [N · m] [(oz · in)]	Inertia moment J [ $\times 10^{-4} \text{kg} \cdot \text{m}^2$ ] ( $\text{WK}^2$ [oz · in <sup>2</sup> ])	Mass [kg] (lb)
HF-SP102BG7 HF-SP1024BG7	1.0	HPG-50A-33-J2AABC-S	1/33	8.5 (1200)	18.7 (102)	27.5 (60.6)
		HPG-50A-45-J2AABC-S	1/45			

[Unit: mm]

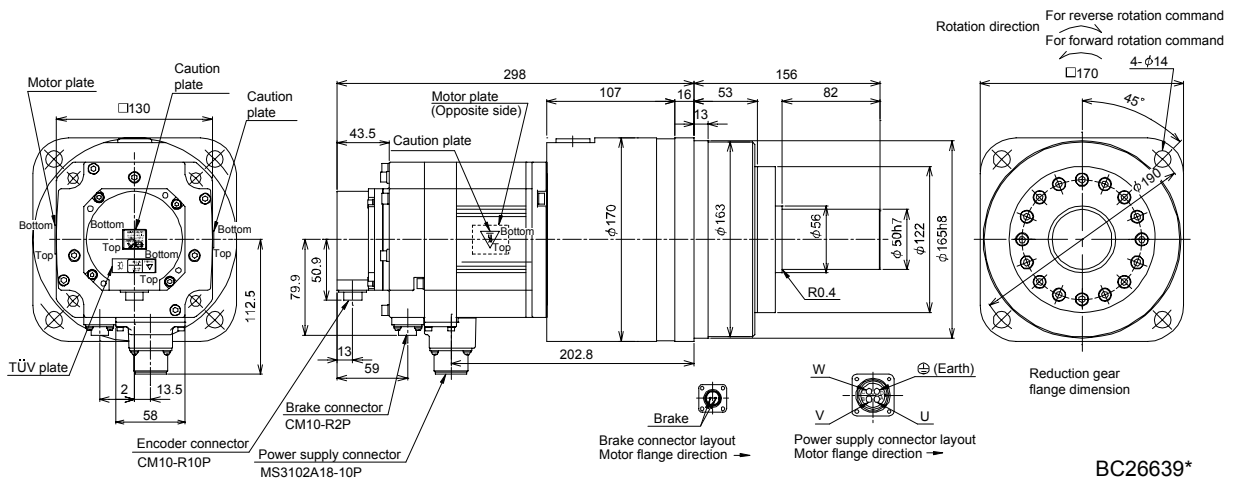

Model	Output [kW]	Reduction gear model	Reduction ratio (Actual reduction ratio)	Brake static friction torque [N · m] [(oz · in)]	Inertia moment J [ $\times 10^{-4} \text{kg} \cdot \text{m}^2$ ] ( $\text{WK}^2$ [oz · in <sup>2</sup> ])	Mass [kg] (lb)
HF-SP152BG7 HF-SP1524BG7	1.5	HPG-20A-05-J2KSAWS-S	1/5	8.5 (1200)	20.7 (113)	13.5 (29.8)

[Unit: mm]

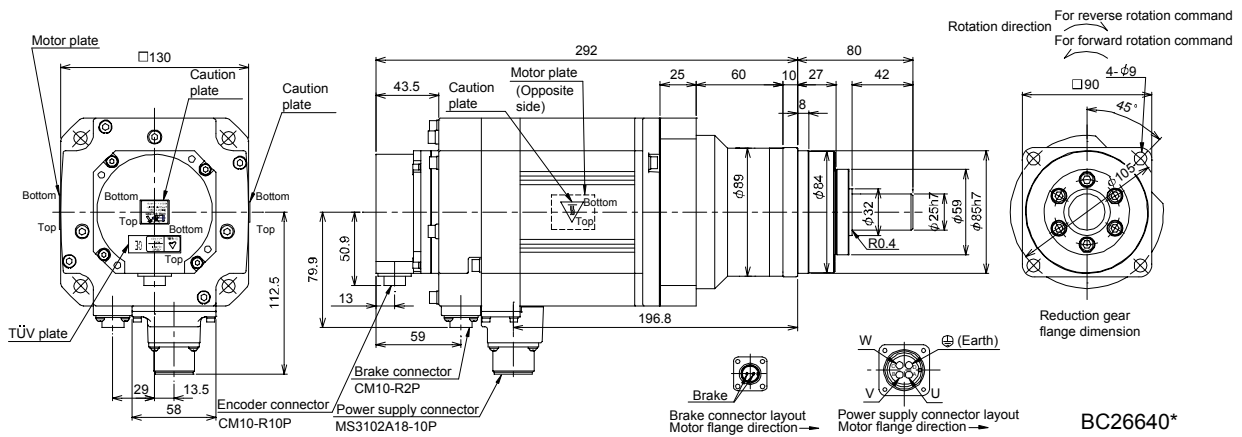



# 7. HF-SP SERIES

Model	Output [kW]	Reduction gear model	Reduction ratio (Actual reduction ratio)	Brake static friction torque [N · m] ([oz · in])	Inertia moment J [ $\times 10^{-4}$ kg · m <sup>2</sup> ] (WK <sup>2</sup> [oz · in <sup>2</sup> ])	Mass [kg] ([lb])
HF-SP152BG7 HF-SP1524BG7	1.5	HPG-32A-11-J2MCSPS-S	1/11	8.5 (1200)	23.4 (128)	18.2 (40.1)

[Unit: mm]

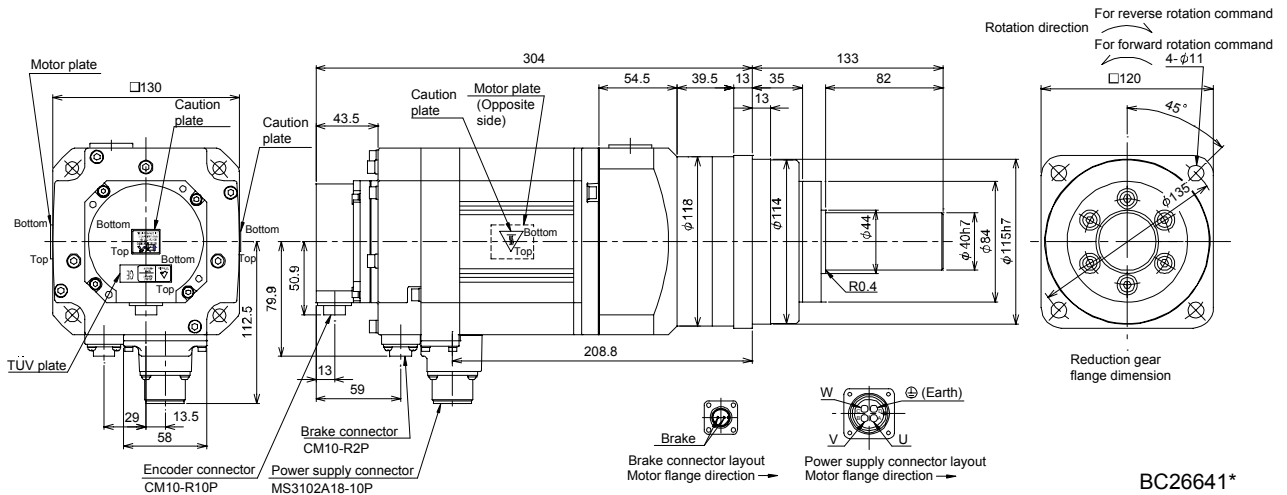

Model	Output [kW]	Reduction gear model	Reduction ratio (Actual reduction ratio)	Brake static friction torque [N · m] ([oz · in])	Inertia moment J [ $\times 10^{-4}$ kg · m <sup>2</sup> ] (WK <sup>2</sup> [oz · in <sup>2</sup> ])	Mass [kg] ([lb])
HF-SP152BG7 HF-SP1524BG7	1.5	HPG-50A-21-J2AABC-S	1/21	8.5 (1200)	25.7 (141)	29.3 (64.6)
		HPG-50A-33-J2AABC-S	1/33		24.7 (135)	
		HPG-50A-45-J2AABC-S	1/45			

[Unit: mm]

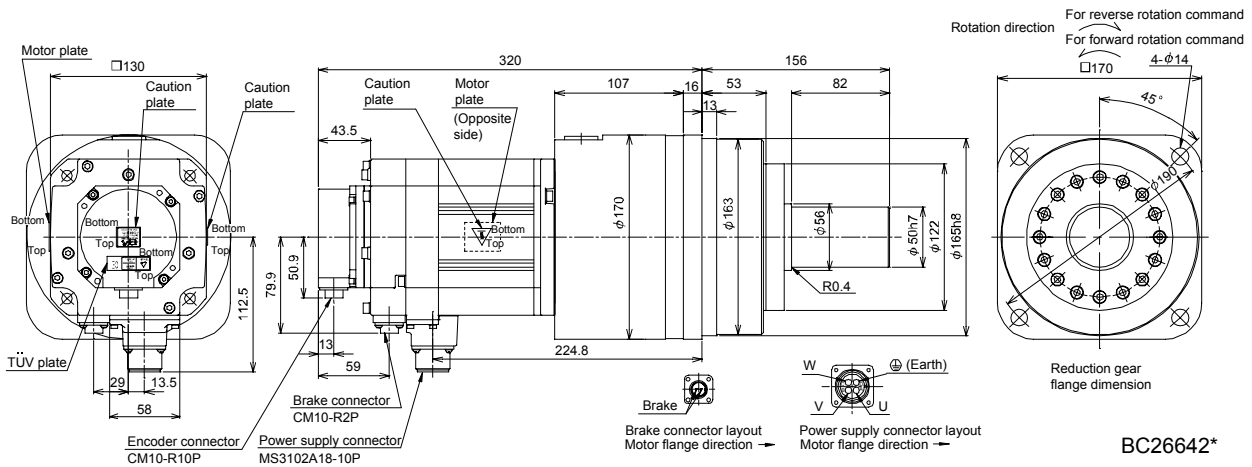

# 7. HF-SP SERIES

Model	Output [kW]	Reduction gear model	Reduction ratio (Actual reduction ratio)	Brake static friction torque [N · m] ([oz · in])	Inertia moment J [ $\times 10^{-4}$ kg · m <sup>2</sup> ] (WK <sup>2</sup> [oz · in <sup>2</sup> ])	Mass [kg] ([lb])
HF-SP202BG7	2.0	HPG-32A-05-J2PBZL-S	1/5	44 (6230)	52.8 (289)	26.9 (59.3)
HF-SP2024BG7		HPG-32A-11-J2PBZJ-S	1/11		52.4 (286)	27.4 (60.4)

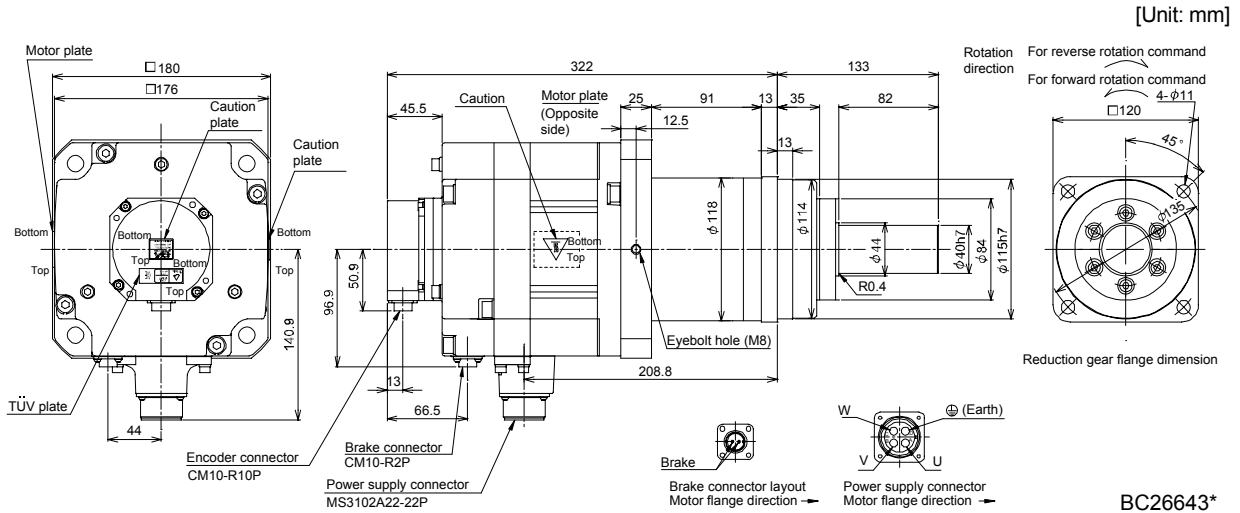

Model	Output [kW]	Reduction gear model	Reduction ratio (Actual reduction ratio)	Brake static friction torque [N · m] ([oz · in])	Inertia moment J [ $\times 10^{-4}$ kg · m <sup>2</sup> ] (WK <sup>2</sup> [oz · in <sup>2</sup> ])	Mass [kg] ([lb])
HF-SP202BG7	2.0	HPG-50A-21-J2BBDF-S	1/21	44 (6230)	54.4 (297)	38.1 (84.0)
HF-SP2024BG7		HPG-50A-33-J2BBDF-S	1/33		53.3 (291)	
		HPG-50A-45-J2BBDF-S	1/45			

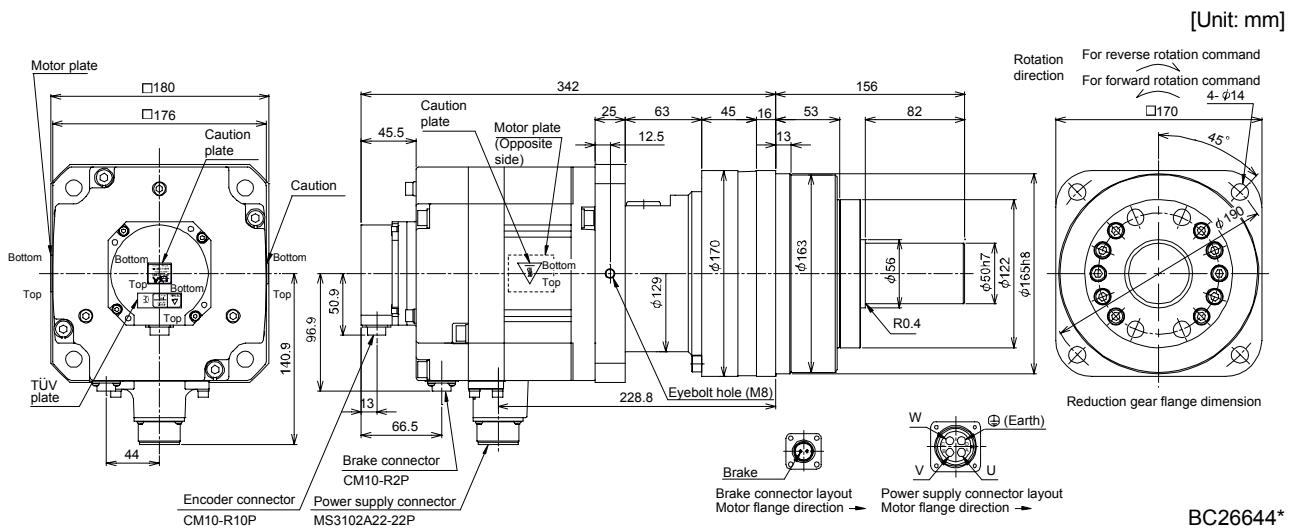

# 7. HF-SP SERIES

Model	Output [kW]	Reduction gear model	Reduction ratio (Actual reduction ratio)	Brake static friction torque [N · m] ([oz · in])	Inertia moment J [ $\times 10^{-4}$ kg · m <sup>2</sup> ] (WK <sup>2</sup> [oz · in <sup>2</sup> ])	Mass [kg] ([lb])
HF-SP352BG7 HF-SP3524BG7	3.5	HPG-32A-05-J2PBZI-S	1/5	44 (6230)	89.6 (490)	33.9 (74.7)

[Unit: mm]

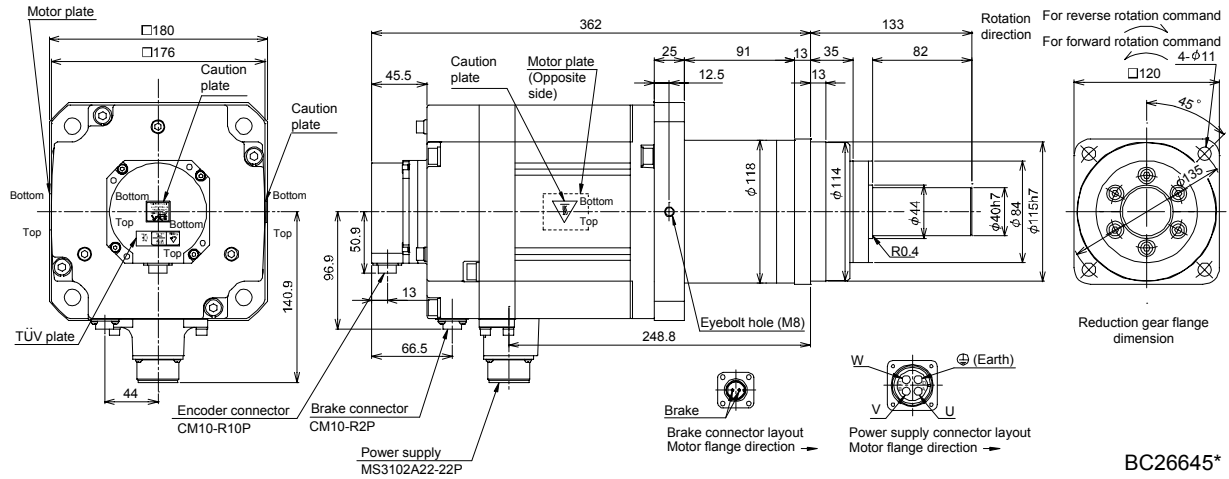

BC26645\*

Model	Output [kW]	Reduction gear model	Reduction ratio (Actual reduction ratio)	Brake static friction torque [N · m] ([oz · in])	Inertia moment J [ $\times 10^{-4}$ kg · m <sup>2</sup> ] (WK <sup>2</sup> [oz · in <sup>2</sup> ])	Mass [kg] ([lb])
HF-SP352BG7	3.5	HPG-50A-11-J2BBDF-S	1/11	44 (6230)	93.1 (509)	45.1 (99.4)
HF-SP3524BG7		HPG-50A-21-J2BBDF-S	1/21		91.2 (499)	

[Unit: mm]

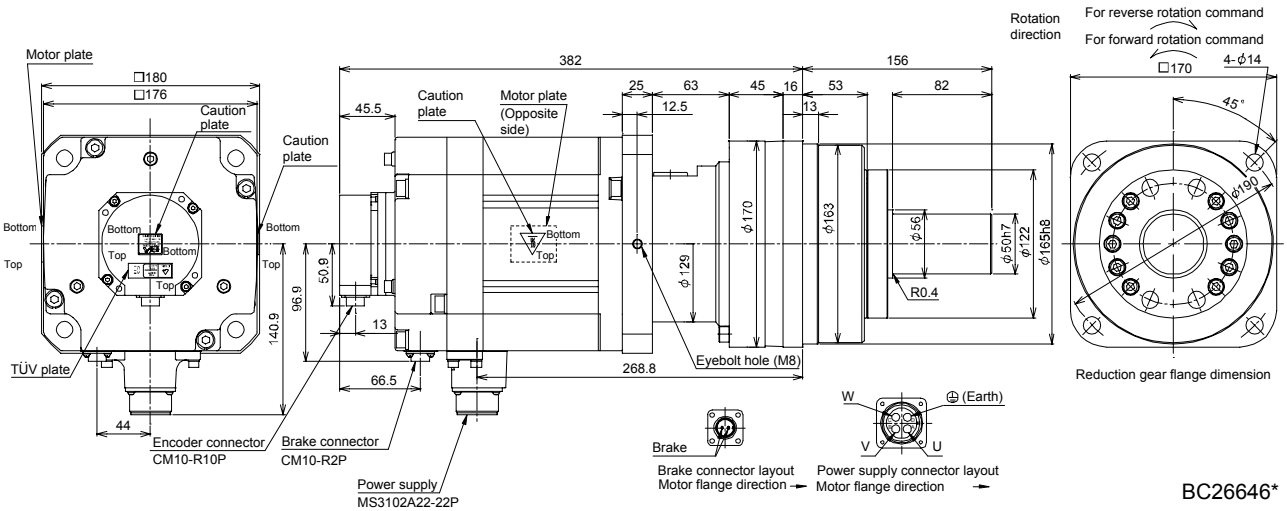

BC26646\*

## 7. HF-SP SERIES

Model	Output [kW]	Reduction gear model	Reduction ratio (Actual reduction ratio)	Brake static friction torque [N · m] (oz · in)	Inertia moment J [ $\times 10^{-4}$ kg · m <sup>2</sup> ] (WK <sup>2</sup> [oz · in <sup>2</sup> ])	Mass [kg] (lb)
HF-SP502BG7	5.0	HPG-50A-05-J2BBCF-S	1/5	44 (6230)	118.5 (648)	47.6 (105)
HF-SP5024BG7		HPG-50A-11-J2BDDF-S	1/11		115.4 (631)	49.1 (108)

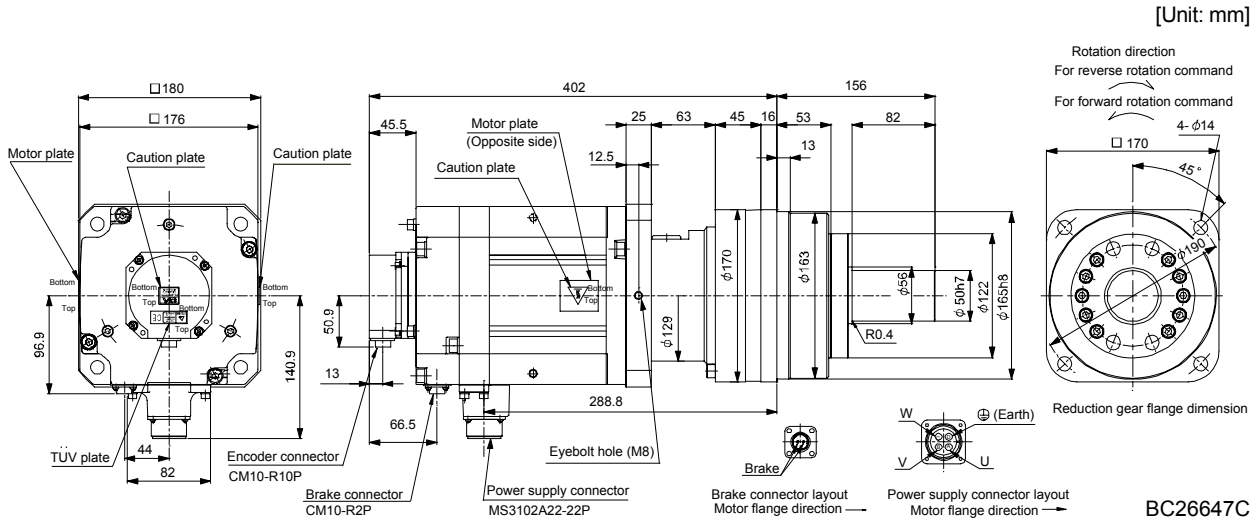

Model	Output [kW]	Reduction gear model	Reduction ratio (Actual reduction ratio)	Brake static friction torque [N · m] (oz · in)	Inertia moment J [ $\times 10^{-4}$ kg · m <sup>2</sup> ] (WK <sup>2</sup> [oz · in <sup>2</sup> ])	Mass [kg] (lb)
HF-SP702BG7	7.0	HPG-50A-05-J2BBCF-S	1/5	44 (6230)	175.5 (960)	56.6 (125)
HF-SP7024BG7						

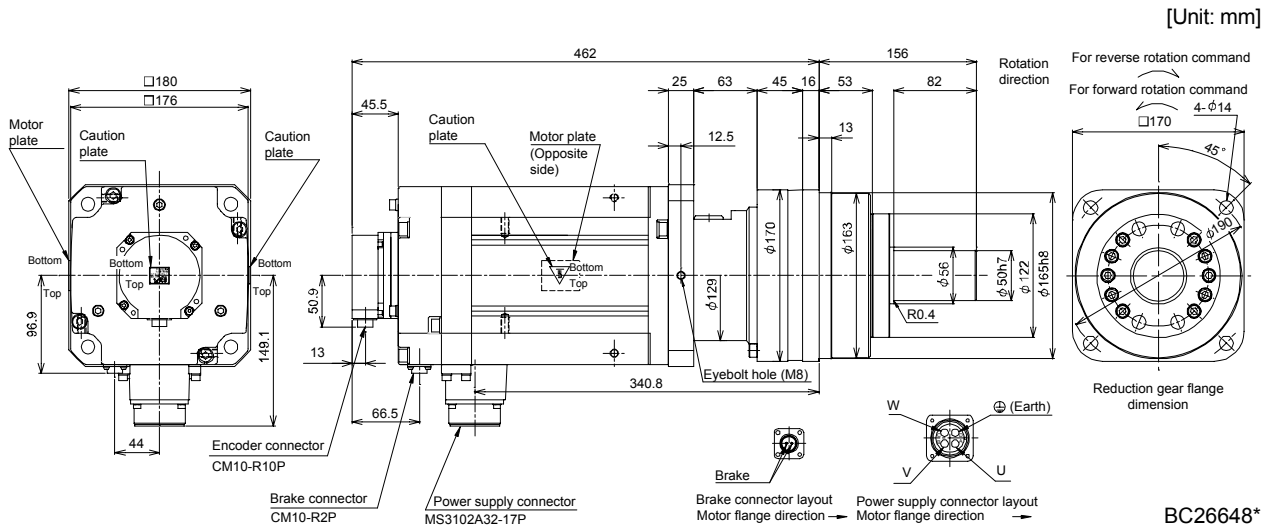



# 8. HA-LP SERIES

## 8. HA-LP SERIES

This chapter provides information on the servo motor specifications and characteristics. When using the HA-LP series servo motor, always read the Safety Instructions in the beginning of this manual and chapters 1 to 4, in addition to this chapter.

### 8.1 Model name make up

The following describes what each block of a model name indicates. Note that not all the combinations of the symbols exist.

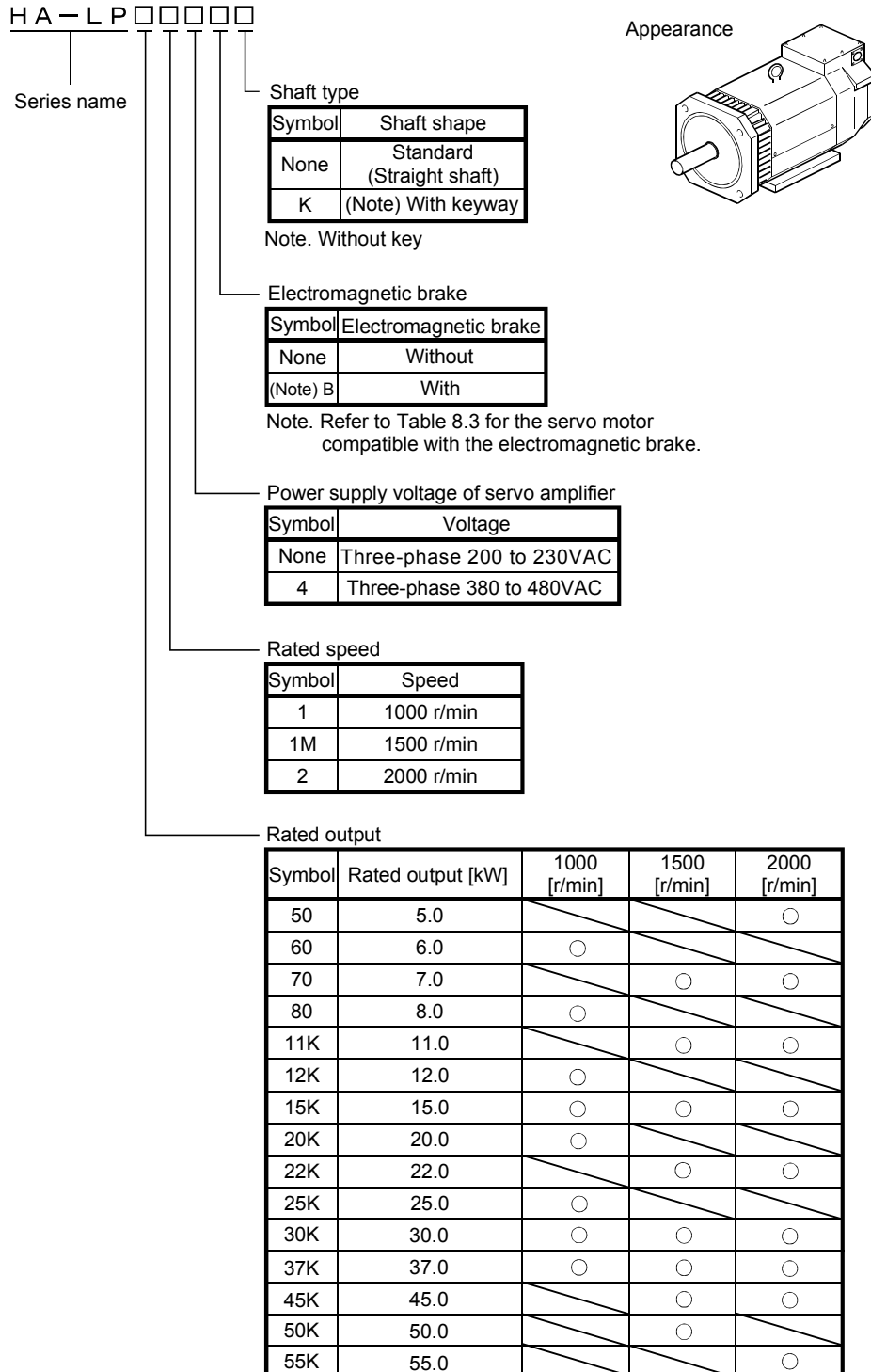

## 8. HA-LP SERIES

### 8.2 Standard specifications

#### 8.2.1 Standard specifications list

Servo motor		HA-LP 1000r/min series (200VAC-compatible, low inertia * middle large capacity)							
		601	801	12K1	15K1	20K1	25K1	30K1 (Note 9)	37K1 (Note 9)
Item									
Applicable servo amplifier/drive unit	MR-J3-□A/B/B-RJ006/T	700	11K		15K	22K		DU30K	DU37K
Applicable converter unit									MR-J3-CR-55K
Continuous running duty (Note 1)	Rated output [kW]	6.0	8.0	12.0	15.0	20.0	25.0	30.0	37.0
	Rated torque [N·m] [oz·in]	57.3 8110	76.4 10800	115 16300	143 20300	191 27000	239 33800	286 40500	353 50000
Rated speed (Note 1)	[r/min]	1000							
Maximum speed	[r/min]	1200							
Instantaneous permissible speed	[r/min]	1380							
Maximum torque	[N·m]	172	229	344	415	477	597	716	883
	[oz·in]	24400	32400	48700	58800	67500	84500	101000	125000
Power rate at continuous rated torque	[kW/s]	313	265	445	373	561	528	626	668
Inertia moment (Note 3)	J [ $\times 10^{-4}$ kg·m <sup>2</sup> ]	105	220	295	550	650	1080	1310	1870
	WK <sup>2</sup> [oz·in <sup>2</sup> ]	574	1200	1610	3010	3550	5900	7160	10200
Recommended ratio of load inertia moment to servo motor shaft inertia moment (Note 2)		10 times or less							
Power supply capacity		Refer to "Power supply equipment capacity and generated loss of servo amplifiers" in Servo Amplifier Instruction Manual.							
Rated current	[A]	34	42	61	83	118	118	154	188
Maximum current	[A]	102	126	183	249	295	295	385	470
Speed/position detector		Encoder common to absolute position and incremental detection systems (Resolution per servo motor 1 rotation: 262144 pulse/rev)							
Cooling fan	Power supply	Voltage * frequency	One-phase 200 to 220 VAC/50Hz, One-phase 200 to 230 VAC/60Hz		Three-phase 200 to 230VAC 50Hz/60Hz				
		Power consumption [W]	42(50Hz)/ 54(60Hz)	62(50Hz)/ 76(60Hz)	65(50Hz)/ 85(60Hz)	120(50Hz)/ 175(60Hz)			
	Rated current [A]	0.21(50Hz)/ 0.25(60Hz)	0.18(50Hz)/ 0.17(60Hz)	0.20(50Hz)/ 0.22(60Hz)	0.65(50Hz)/ 0.80(60Hz)				
Thermal sensor	Maximum rating	125VAC/DC, 3A or 250VAC/DC, 2A							
	Minimum rating	6VAC/DC, 0.15A							
Accessory		Oil seal							
Insulation class		155(F)							
Structure		Totally-enclosed, force-cooled (IP rating: IP44 (Note 4))							
Environmental conditions (Note 5)	Ambient temperature	Operation	[°C]	0 to 40 (non-freezing)					
			[°F]	32 to 104 (non-freezing)					
		Storage	[°C]	-15 to 70 (non-freezing)					
			[°F]	5 to 158 (non-freezing)					
	Ambient humidity	Operation	80%RH or less (non-condensing)						
		Storage	90%RH or less (non-condensing)						
	Ambience	Indoors (no direct sunlight) Free from corrosive gas, flammable gas, oil mist, dust and dirt.							
Altitude	Max.1000m above sea level								
Vibration resistance (Note 6)	[m/s <sup>2</sup> ]	X, : 11.7, Y : 29.4			X, Y: 9.8				
Vibration rank (Note 7)		V10							
Permissible load for the shaft (Note 8)	L [mm]		85	110	140		170		
		Radial	[N]	2450	2940	3234		4900	6370
		[lb]	551	661	727		1100	1430	
	Thrust	[N]	980		1470		1960		
	[lb]	220		330		441			
Mass (Note 3)	[kg]	55	95	115	160	180	230	250	335
	[lb]	121	209	254	353	397	507	551	739

## 8. HA-LP SERIES

Item		HA-LP 1500r/min series (200VAC-compatible, low inertia * middle large capacity)						
		701M	11K1M	15K1M	22K1M	30K1M (Note 9)	37K1M (Note 9)	
Applicable servo amplifier/drive unit	MR-J3-□A/B/B-RJ006/T	700	11K	15K	22K	DU30K	DU37K	
Applicable converter unit		MR-J3-CR-55K						
Continuous running duty (Note 1)	Rated output [kW]	7.0	11.0	15.0	22.0	30.0	37.0	
	Rated torque	[N · m]	44.6	70	95.5	140	191	236
		[oz · in]	6320	9910	13500	19800	27000	33400
Rated speed (Note 1) [r/min]		1500						
Maximum speed [r/min]		2000						
Instantaneous permissible speed [r/min]		2300						
Maximum torque	[N · m]	134	210	286	350	477	589	
	[oz · in]	19000	29700	40500	49600	67500	83400	
Power rate at continuous rated torque [kW/s]		189	223	309	357	561	514	
Inertia moment (Note 3)	J [ $\times 10^{-4}$ kg · m <sup>2</sup> ]	105	220	295	550	650	1080	
	WK <sup>2</sup> [oz · in <sup>2</sup> ]	574	1200	1610	3010	3550	5900	
Recommended ratio of load inertia moment to servo motor shaft inertia moment (Note 2)		10 times or less						
Power supply capacity		Refer to "Power supply equipment capacity and generated loss of servo amplifiers" in Servo Amplifier Instruction Manual.						
Rated current [A]		37	65	87	126	174	202	
Maximum current [A]		111	195	261	315	435	505	
Speed/position detector		Encoder common to absolute position and incremental detection systems (Resolution per servo motor 1 rotation: 262144 pulse/rev)						
Cooling fan	Power supply	Voltage · frequency	One-phase 200 to 220 VAC/50Hz, One-phase 200 to 230 VAC/60Hz		Three-phase 200 to 230VAC 50Hz/60Hz			
		Power consumption [W]	42(50Hz)/54(60Hz)	62(50Hz)/76(60Hz)	65(50Hz)/85(60Hz)	120(50Hz)/175(60Hz)		
	Rated current [A]	0.21(50Hz)/0.25(60Hz)	0.18(50Hz)/0.17(60Hz)	0.20(50Hz)/0.22(60Hz)	0.65(50Hz)/0.80(60Hz)			
Thermal sensor	Maximum rating	125VAC/DC, 3A or 250VAC/DC, 2A						
	Minimum rating	6VAC/DC, 0.15A						
Accessory		Oil seal						
Insulation class		155(F)						
Structure		Totally-enclosed, force-cooled (IP rating: IP44 (Note 4))						
Environmental conditions (Note 5)	Ambient temperature	Operation	[°C]	0 to 40 (non-freezing)				
			[°F]	32 to 104 (non-freezing)				
		Storage	[°C]	-15 to 70 (non-freezing)				
			[°F]	5 to 158 (non-freezing)				
	Ambient humidity	Operation	80%RH or less (non-condensing)					
		Storage	90%RH or less (non-condensing)					
	Ambience	Indoors (no direct sunlight) Free from corrosive gas, flammable gas, oil mist, dust and dirt.						
Altitude	Max.1000m above sea level							
Vibration resistance (Note 6)	[m/s <sup>2</sup> ]	X, : 11.7, Y : 29.4			X, Y: 9.8			
Vibration rank (Note 7)		V10						
Permissible load for the shaft (Note 8)	L [mm]	85	110		140			
		Radial	[N]	2450	2940	3234	4900	
	[lb]		551	661	727	1100		
	Thrust	[N]	980		1470	6370		
		[lb]	220		330	1430		
Mass (Note 3)	[kg]	55	95	115	160	180	230	
	[lb]	121	209	254	353	397	507	



## 8. HA-LP SERIES

Servo motor		HA-LP 2000r/min series (200VAC-compatible, low inertia * middle large capacity)						
		502	702	11K2	15K2	22K2	30K2 (Note 9)	37K2 (Note 9)
Item								
Applicable servo amplifier/drive unit	MR-J3-□A/B/B-RJ006/T	500	700	11K	15K	22K	DU30K	DU37K
Applicable converter unit							MR-J3-CR-55K	
Continuous running duty (Note 1)	Rated output [kW]	5.0	7.0	11.0	15.0	22.0	30.0	37.0
	Rated torque							
	[N · m]	23.9	33.4	52.5	71.6	105	143	177
	[oz · in]	3380	4730	7430	10100	14900	20300	25100
Rated speed (Note 1)	[r/min]	2000						
Maximum speed	[r/min]	2000						
Instantaneous permissible speed	[r/min]	2300						
Maximum torque	[N · m]	71.6	100	158	215	263	358	442
	[oz · in]	10100	14200	22400	30400	37200	50700	62600
Power rate at continuous rated torque	[kW/s]	77.2	118	263	233	374	373	480
Inertia moment (Note 3)	J [ $\times 10^{-4}$ kg · m <sup>2</sup> ]	74	94.2	105	220	295	550	650
	WK <sup>2</sup> [oz · in <sup>2</sup> ]	405	515	574	1200	1610	3010	3550
Recommended ratio of load inertia moment to servo motor shaft inertia moment (Note 2)		10 times or less						
Power supply capacity		Refer to "Power supply equipment capacity and generated loss of servo amplifiers" in Servo Amplifier Instruction Manual.						
Rated current	[A]	25	34	63	77	112	166	204
Maximum current	[A]	75	102	189	231	280	415	510
Speed/position detector		Encoder common to absolute position and incremental detection systems (Resolution per servo motor 1 rotation: 262144 pulse/rev)						
Cooling fan	Power supply	Voltage * frequency			One-phase 200 to 220 VAC/50Hz, One-phase 200 to 230 VAC/60Hz	Three-phase 200 to 230VAC 50Hz/60Hz		
		Power consumption [W]			42(50Hz)/ 54(60Hz)	62(50Hz)/ 76(60Hz)	65(50Hz)/ 85(60Hz)	
	Rated current [A]			0.21(50Hz)/ 0.25(60Hz)	0.18(50Hz)/ 0.17(60Hz)	0.20(50Hz)/ 0.22(60Hz)		
Thermal sensor	Maximum rating			125VAC/DC, 3A or 250VAC/DC, 2A				
	Minimum rating			6VAC/DC, 0.15A				
Accessory		Oil seal						
Insulation class		155(F)						
Structure		Totally enclosed, natural cooling (IP rating: IP65 (Note 4))			Totally-enclosed, force-cooled (IP rating: IP44 (Note 4))			
Environmental conditions (Note 5)	Ambient temperature	Operation	[°C]	0 to 40 (non-freezing)				
			[°F]	32 to 104 (non-freezing)				
		Storage	[°C]	-15 to 70 (non-freezing)				
			[°F]	5 to 158 (non-freezing)				
	Ambient humidity	Operation	80%RH or less (non-condensing)					
		Storage	90%RH or less (non-condensing)					
	Ambience	Indoors (no direct sunlight) Free from corrosive gas, flammable gas, oil mist, dust and dirt.						
	Altitude	Max.1000m above sea level						
Vibration resistance (Note 6)	[m/s <sup>2</sup> ]	X, Y : 11.7, Y : 29.4					X, Y : 9.8	
Vibration rank (Note 7)		V10						
Permissible load for the shaft (Note 8)	L [mm]		85		110	140		
		Radial	[N]	2450		2940	3234	
	[lb]		551		661	727		
	Thrust	[N]	980					1470
[lb]		220					330	
Mass (Note 3)	[kg]	28	35	55	95	115	160	180
	[lb]	61.7	77.2	121	209	254	353	397

## 8. HA-LP SERIES

Item		Servo motor		HA-LP 1000r/min series (400VAC-compatible, low inertia * large capacity)							
				6014	8014	12K14	15K14	20K14	25K14 (Note 9)	30K14 (Note 9)	37K14 (Note 9)
Applicable servo amplifier/drive unit	MR-J3-□A4/B4/ B4-RJ006/T4			700	11K		15K	22K	DU30K		DU37K
Applicable converter unit				MR-J3-CR-55K4							
Continuous running duty (Note 1)	Rated output [kW]		6.0	8.0	12.0	15.0	20.0	25.0	30.0	37.0	
	Rated torque	[N · m]	57.3	76.4	115	143	191	239	286	353	
[oz · in]		8110	10800	16300	20300	27000	33900	40500	50000		
Rated speed (Note 1)		[r/min]	1000								
Maximum speed		[r/min]	1200								
Instantaneous permissible speed		[r/min]	1380								
Maximum torque		[N · m]	172	229	344	415	477	597	716	883	
		[oz · in]	24400	32400	48700	58800	67500	84500	101000	125000	
Power rate at continuous rated torque		[kW/s]	313	265	445	373	561	528	626	668	
Inertia moment (Note 3)	J [ $\times 10^{-4}$ kg · m <sup>2</sup> ]		105	220	295	550	650	1080	1310	1870	
	WK <sup>2</sup> [oz · in <sup>2</sup> ]		574	1200	1610	3010	3550	5900	7160	10200	
Recommended ratio of load inertia moment to servo motor shaft inertia moment (Note 2)				10 times or less							
Power supply capacity				Refer to "Power supply equipment capacity and generated loss of servo amplifiers" in Servo Amplifier Instruction Manual.							
Rated current		[A]	17	20	30	40	55	70	77	95	
Maximum current		[A]	51	60	90	120	138	175	193	238	
Speed/position detector				Encoder common to absolute position and incremental detection systems (Resolution per servo motor 1 rotation: 262144 pulse/rev)							
Cooling fan	Power supply	Voltage * frequency		One-phase 200 to 220 VAC/50Hz, One-phase 200 to 230 VAC/60Hz	Three-phase 380 to 440VAC 50Hz Three-phase 380 to 480VAC 60Hz	Three-phase 380 to 460VAC 50Hz Three-phase 380 to 480VAC 60Hz					
		Power consumption [W]		42(50Hz)/ 54(60Hz)	62(50Hz)/ 76(60Hz)	65(50Hz)/ 85(60Hz)	110(50Hz)/150(60Hz)				
	Rated current [A]		0.21(50Hz)/ 0.25(60Hz)	0.14(50Hz)/ 0.11(60Hz)	0.12(50Hz)/ 0.14(60Hz)	0.20(50Hz)/0.22(60Hz)					
Thermal sensor	Maximum rating		125VAC/DC, 3A or 250VAC/DC, 2A								
	Minimum rating		6VAC/DC, 0.15A								
Accessory				Oil seal							
Insulation class				155(F)							
Structure				Totally-enclosed, force-cooled (IP rating: IP44 (Note 4))							
Environmental conditions (Note 5)	Ambient temperature	Operation	[°C]	0 to 40 (non-freezing)							
			[°F]	32 to 104 (non-freezing)							
		Storage	[°C]	-15 to 70 (non-freezing)							
			[°F]	5 to 158 (non-freezing)							
	Ambient humidity	Operation		80%RH or less (non-condensing)							
		Storage		90%RH or less (non-condensing)							
	Ambience		Indoors (no direct sunlight) Free from corrosive gas, flammable gas, oil mist, dust and dirt.								
Altitude		Max.1000m above sea level									
Vibration resistance (Note 6)		[m/s <sup>2</sup> ]	X : 11.7 Y : 29.4				X, Y : 9.8				
Vibration rank (Note 7)				V10							
Permissible load for the shaft (Note 8)	L [mm]	85		110		140		170			
		Radial	[N]	2450	2940	3234	4900	6370			
	[lb]		551	661	727	1100	1430				
	Thrust	[N]	980		1470		1960				
		[lb]	220		330		441				
Mass (Note 3)	[kg]	55	95	115	160	180	230	250	335		
	[lb]	121	209	254	353	397	507	551	739		

## 8. HA-LP SERIES

Item		Servo motor	HA-LP 1500r/min series (400VAC-compatible, low inertia * large capacity)								
			701M4	11K1M4	15K1M4	22K1M4	30K1M4 (Note 9)	37K1M4 (Note 9)	45K1M4 (Note 9)	50K1M4 (Note 9)	
Applicable servo amplifier/drive unit	MR-J3-□A4/B4/B4-RJ006/T4		700	11K	15K	22K	DU30K	DU37K	DU45K	DU55K	
Applicable converter unit		MR-J3-CR-55K4									
Continuous running duty (Note 1)	Rated output	[kW]	7.0	11.0	15.0	22.0	30.0	37.0	45.0	50.0	
	Rated torque	[N · m]	44.6	70.0	95.5	140	191	236	286	318	
		[oz · in]	6320	9910	13500	19800	27000	33400	40500	45000	
Rated speed (Note 1)		[r/min]	1500								
Maximum speed		[r/min]	2000								
Instantaneous permissible speed		[r/min]	2300								
Maximum torque		[N · m]	134	210	286	350	477	589	716	796	
		[oz · in]	19000	29700	40500	49600	67500	83400	101000	113000	
Power rate at continuous rated torque		[kW/s]	189	223	309	357	561	514	626	542	
Inertia moment (Note 3)	J	[ $\times 10^{-4}$ kg · m <sup>2</sup> ]	105	220	295	550	650	1080	1310	1870	
	WK <sup>2</sup>	[oz · in <sup>2</sup> ]	574	1200	1610	3010	3550	5900	7160	10200	
Recommended ratio of load inertia moment to servo motor shaft inertia moment (Note 2)		10 times or less									
Power supply capacity		Refer to "Power supply equipment capacity and generated loss of servo amplifiers" in Servo Amplifier Instruction Manual.									
Rated current		[A]	18	31	41	63	87	101	128	143	
Maximum current		[A]	54	93	123	158	218	253	320	358	
Speed/position detector		Encoder common to absolute position and incremental detection systems (Resolution per servo motor 1 rotation: 262144 pulse/rev)									
Cooling fan	Power supply	Voltage · frequency	One-phase 200 to 220 VAC/50Hz, One-phase 200 to 230 VAC/60Hz	Three-phase 380 to 440VAC 50Hz Three-phase 380 to 480VAC 60Hz	Three-phase 380 to 460VAC 50Hz Three-phase 380 to 480VAC 60Hz						
		Power consumption [W]	42(50Hz)/54(60Hz)	62(50Hz)/76(60Hz)	65 (50Hz)/85 (60 Hz)	110(50Hz)/150(60Hz)					
	Rated current [A]	0.21(50Hz)/0.25(60Hz)	0.14(50Hz)/0.11(60Hz)	0.12 (50Hz)/0.14 (60 Hz)	0.20(50Hz)/0.22(60Hz)						
Thermal sensor	Maximum rating	125VAC/DC, 3A or 250VAC/DC, 2A									
	Minimum rating	6VAC/DC, 0.15A									
Accessory		Oil seal									
Insulation class		155(F)									
Structure		Totally-enclosed, force-cooled (IP rating: IP44 (Note 4))									
Environmental conditions (Note 5)	Ambient temperature	Operation	[°C]	0 to 40 (non-freezing)							
			[°F]	32 to 104 (non-freezing)							
		Storage	[°C]	-15 to 70 (non-freezing)							
			[°F]	5 to 158 (non-freezing)							
	Ambient humidity	Operation	80%RH or less (non-condensing)								
		Storage	90%RH or less (non-condensing)								
	Ambience		Indoors (no direct sunlight) Free from corrosive gas, flammable gas, oil mist, dust and dirt.								
	Altitude		Max.1000m above sea level								
Vibration resistance (Note 6)		[m/s <sup>2</sup> ]	X : 11.7, Y : 29.4			X, Y : 9.8					
Vibration rank (Note 7)		V10									
Permissible load for the shaft (Note 8)	L	[mm]	85	110	140			170			
		Radial	[N]	2450	2940	3234		4900	6370		
	[lb]		551	661	727		1100	1430			
	Thrust	[N]	980			1470		1960			
[lb]		220			330		441				
Mass (Note 3)		[kg]	55	95	115	160	180	230	250	335	
		[lb]	121	209	254	353	397	507	551	739	

## 8. HA-LP SERIES

Servo motor		HA-LP 2000r/min series (400VAC-compatible, low inertia * large capacity)						
		11K24	15K24	22K24	30K24 (Note 9)	37K24 (Note 9)	45K24 (Note 9)	55K24 (Note 9)
Applicable servo amplifier/drive unit	MR-J3-□A4/B4/ B4-RJ006/T4	11K	15K	22K	DU30K	DU37K	DU45K	DU55K
Applicable converter unit		MR-J3-CR-55K4						
Continuous running duty (Note 1)	Rated output [kW]	11.0	15.0	22.0	30.0	37.0	45.0	55.0
	Rated torque	[N · m]	52.5	71.6	105	143	177	215
[oz · in]		7430	10100	14900	20300	25100	30400	37200
Rated speed (Note 1)		2000 [r/min]						
Maximum speed		2000 [r/min]						
Instantaneous permissible speed		2300 [r/min]						
Maximum torque	[N · m]	158	215	263	358	442	537	657
	[oz · in]	22400	30400	37200	50700	62600	76100	93000
Power rate at continuous rated torque [kW/s]		263	233	374	373	480	427	526
Inertia moment (Note 3)	J [ $\times 10^{-4}$ kg · m <sup>2</sup> ]	105	220	295	550	650	1080	1310
	WK <sup>2</sup> [oz · in <sup>2</sup> ]	574	1200	1610	3010	3550	5900	7160
Recommended ratio of load inertia moment to servo motor shaft inertia moment (Note 2)		10 times or less						
Power supply capacity		Refer to "Power supply equipment capacity and generated loss of servo amplifiers" in Servo Amplifier Instruction Manual.						
Rated current [A]		32	40	57	83	102	131	143
Maximum current [A]		96	120	143	208	255	328	358
Speed/position detector		Encoder common to absolute position and incremental detection systems (Resolution per servo motor 1 rotation: 262144 pulse/rev)						
Cooling fan	Power supply	Voltage · frequency	One-phase 200 to 220 VAC/50Hz, One-phase 200 to 230 VAC/60Hz	Three-phase 380 to 440VAC 50Hz Three-phase 380 to 480VAC 60Hz	Three-phase 380 to 460VAC 50Hz Three-phase 380 to 480VAC 60Hz			
		Power consumption [W]	42 (50Hz)/ 54 (60 Hz)	62 (50Hz)/ 76 (60 Hz)	65(50Hz)/ 85(60Hz)		110(50Hz)/ 150(60Hz)	
	Rated current [A]	0.21 (50Hz)/ 0.25 (60 Hz)	0.14 (50Hz)/ 0.11 (60 Hz)	0.12(50Hz)/ 0.14(60Hz)		0.20(50Hz)/ 0.22(60Hz)		
Thermal sensor	Maximum rating	125VAC/DC, 3A or 250VAC/DC, 2A						
	Minimum rating	6VAC/DC, 0.15A						
Accessory		Oil seal						
Insulation class		155(F)						
Structure		Totally-enclosed, force-cooled (IP rating: IP44 (Note 4))						
Environmental conditions (Note 5)	Ambient temperature	Operation	[°C]	0 to 40 (non-freezing)				
			[°F]	32 to 104 (non-freezing)				
		Storage	[°C]	-15 to 70 (non-freezing)				
			[°F]	5 to 158 (non-freezing)				
	Ambient humidity	Operation	80%RH or less (non-condensing)					
		Storage	90%RH or less (non-condensing)					
	Ambience	Indoors (no direct sunlight) Free from corrosive gas, flammable gas, oil mist, dust and dirt.						
Altitude	Max.1000m above sea level							
Vibration resistance (Note 6)	[m/s <sup>2</sup> ]	X, : 11.7, Y : 29.4			X, Y : 9.8			
Vibration rank (Note 7)		V10						
Permissible load for the shaft (Note 8)	L [mm]		85	110	140			
		Radial	[N]	2450	2940	3234		4900
	[lb]		551	661	727		1102	
	Thrust	[N]	980			1470		1960
[lb]		220			330		441	
Mass (Note 3)	[kg]	55	95	115	160	180	230	250
	[lb]	121	209	254	353	397	507	551

## 8. HA-LP SERIES

Note 1. When the power supply voltage drops, the output and the rated speed cannot be guaranteed.

2. If the load inertia moment ratio exceeds the indicated value, please consult your local sales office.

3. Refer to the outline dimension drawing for the servo motor with an electromagnetic brake.

4. Except for the shaft – through portion.

5. In the environment where the servo motor is exposed to oil mist, oil and/or water, the servo motor of the standard specifications may not be usable. Please contact your local sales office.

6. The vibration direction is as shown in the figure. The value is the one at the part that indicates the maximum value (normally the opposite-to-load side bracket). When the servo motor stops, fretting is likely to occur at the bearing. Therefore, suppress the vibration to about half of the permissible value.

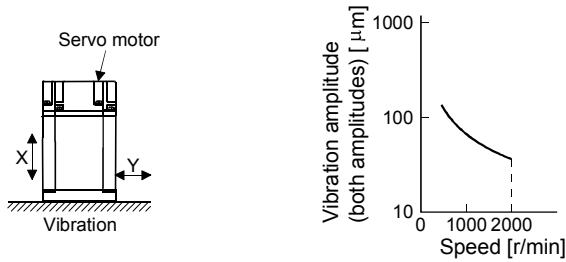

7. V10 indicates that the amplitude of a single servo motor is  $10\mu\text{m}$  or less. The following figure shows the servo motor installation position for measurement and the measuring position.

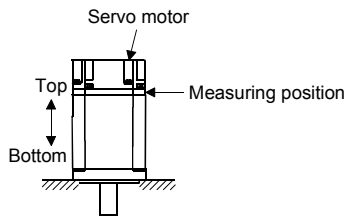

8. For the symbols in the table, refer to the following diagram: Do not subject the shaft to load greater than this value.

The values in the table assume that the loads work singly.

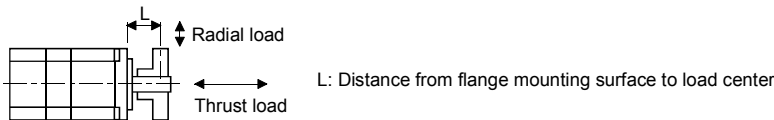

9. Not compliant with servo amplifiers MR-J3-□B-RJ006 and MR-J3-□T.

## 8. HA-LP SERIES

### 8.2.2 Torque characteristics

**POINT**

- For machines which produce unbalance torque, e.g. vertical lift applications, it is recommended to use the servo motor so that the unbalance torque will be within 70% of the rated torque.

#### (1) 3-phase 200VAC

When the power input of the servo amplifier (drive unit) is 3-phase 200VAC, the torque characteristic is indicated by the thin line.

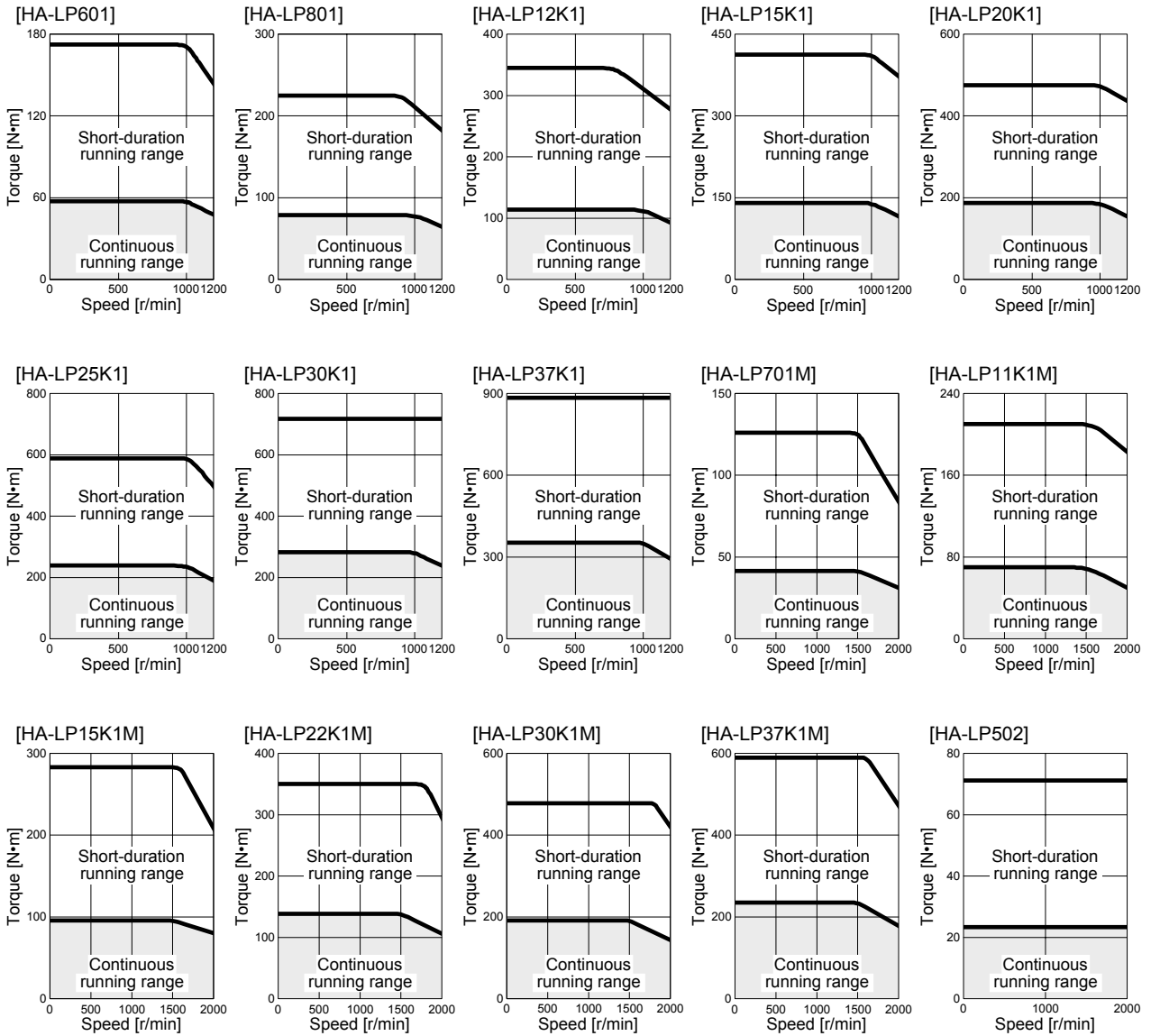

## 8. HA-LP SERIES

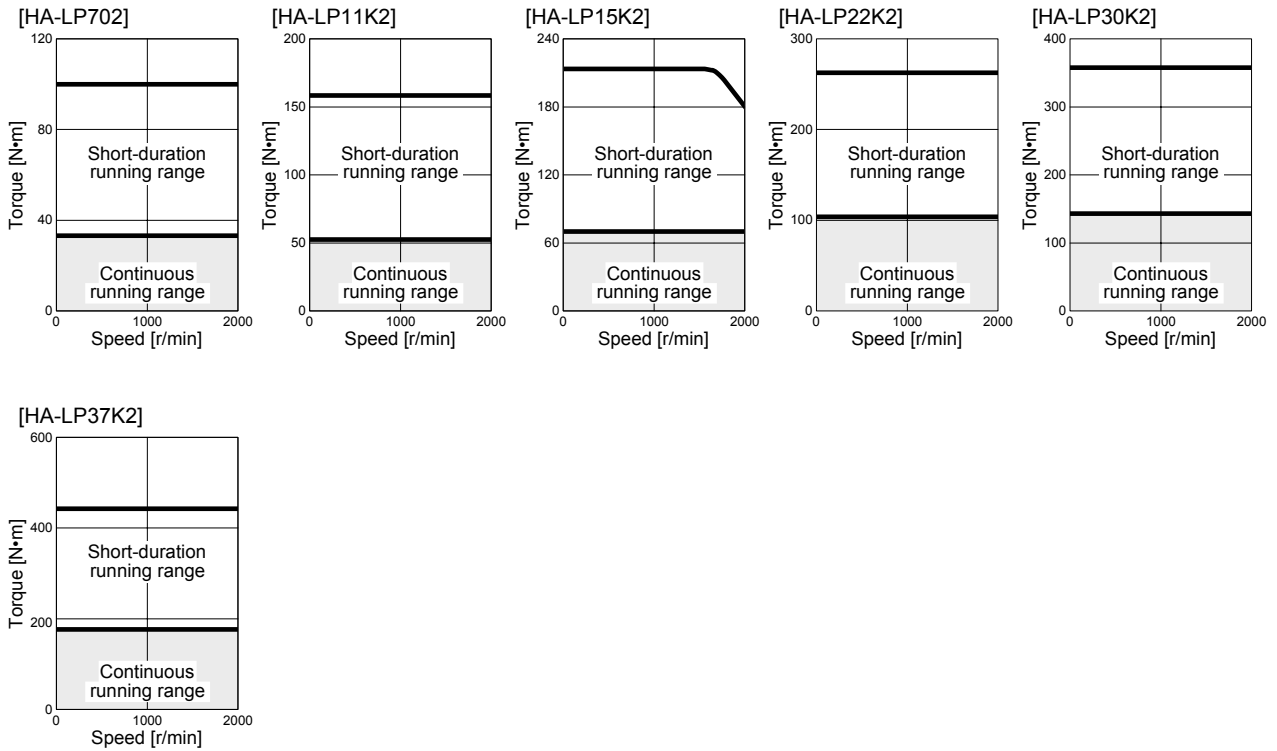

### (2) 3-phase 400VAC

When the power input of the servo amplifier (drive unit) are 3-phase 400VAC, the torque characteristic is indicated by the heavy line. For the 3-phase 380VAC power supply, part of the torque characteristic is indicated by the thin line.

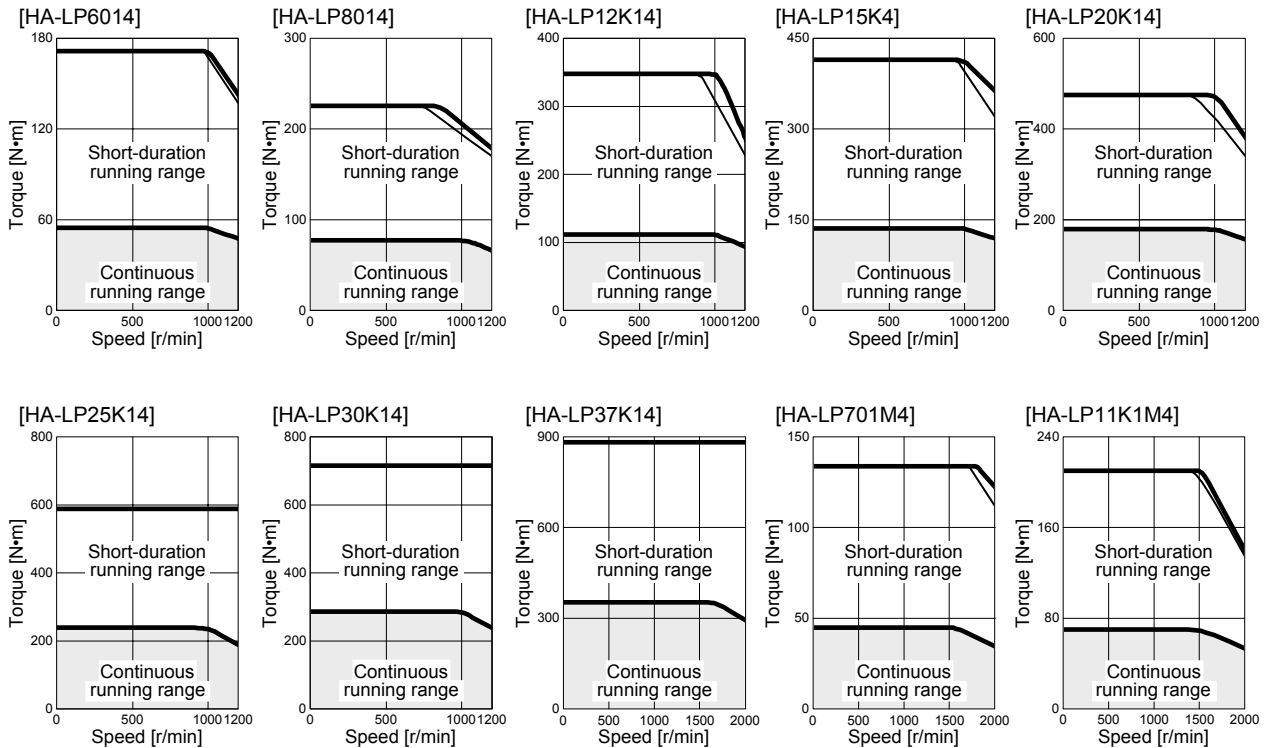

## 8. HA-LP SERIES

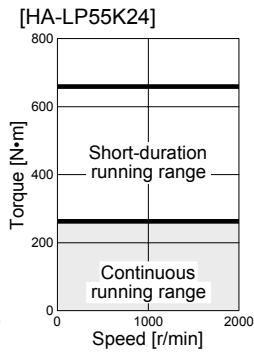
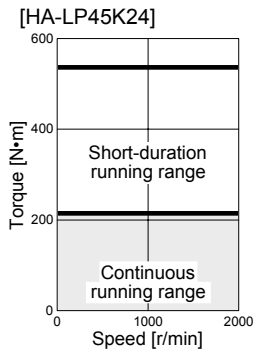
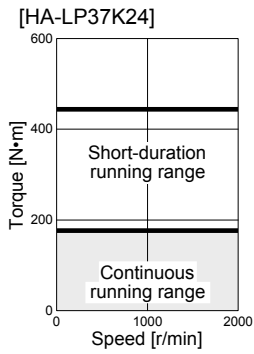
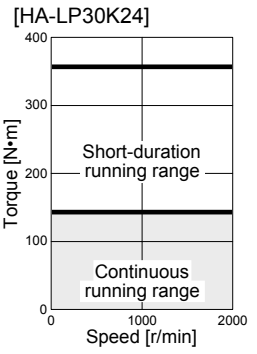
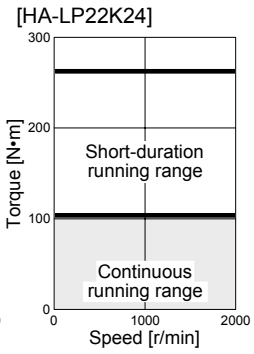
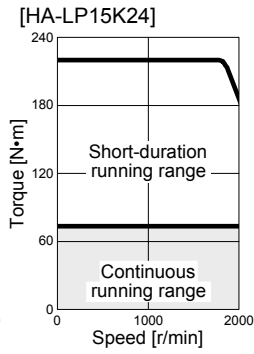
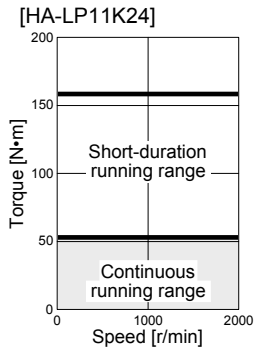
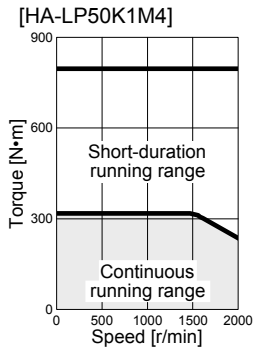
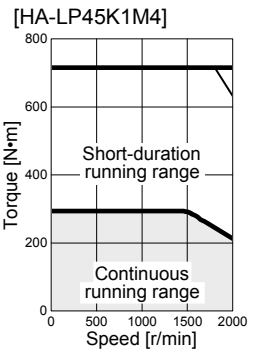
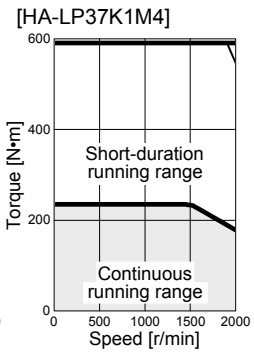
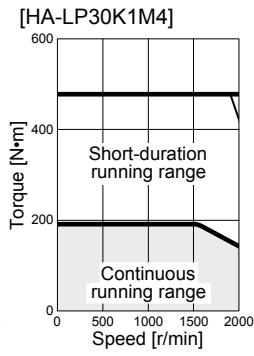
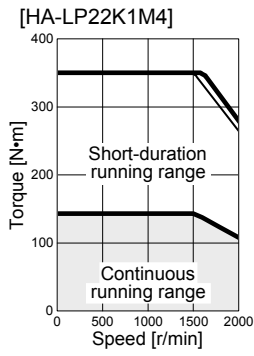
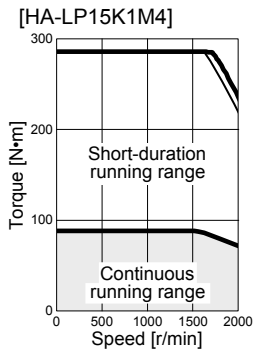



## 8. HA-LP SERIES

### 8.3 Electromagnetic brake



#### CAUTION

- The electromagnetic brake is provided to prevent a drop at a power failure or servo alarm occurrence during vertical drive or to hold a shaft at a stop. Do not use it for normal braking (including braking at servo lock).
- Before performing the operation, be sure to confirm that the electromagnetic brake operates properly.
- The operation time of the electromagnetic brake differs depending on the power supply circuit you use. Be sure to check the operation delay time with a real machine.

The characteristics of the electromagnetic brake provided for the servo motor with an electromagnetic brake are indicated below.

Item	Servo motor	HA-LP series	
		801B · 12K1B 11K1MB · 15K1MB 15K2(4)B · 22K2(4)B	601B 701MB 11K2(4)B
Type (Note 1)		Spring-loaded safety brake	
Rated voltage (Note 4)		24V <sup>0</sup> <sub>-10%</sub> DC	
Capacity	[W] at 20°C (68°F)	46	30
Coil resistance (Note 6)	[Ω]	12.4	19.0
Inductance (Note 6)	[H]	2.96	3.12
Brake static friction torque	[N · m]	160.5	82
	[oz · in]	22700	11600
Release delay time (Note 2)	[s]	0.3	0.25
Braking delay time (Note 2)	[s]	DC off	0.04
Permissible braking work	Per braking [J]	5000	3000
	Per hour [J]	50000	30000
Brake looseness at servo motor shaft (Note 5)	[degrees]	to 0.8	to 0.8
Brake life (Note 3)	Number of braking cycles [times]	20000	20000
	Work per braking [J]	3000	1000
Selection example of surge absorbers to be used (Note 7, 8)	For the suppressed voltage 125V		TND20V-680KB
	For the suppressed voltage 350V	TND10V-221KB	

Note 1. There is no manual release mechanism. When it is necessary to hand-turn the servo motor shaft for machine centering, etc., use a separate 24VDC power supply to release the brake electrically.

2. The value for initial ON gap at 20°C (68°F).

3. The brake gap will increase as the brake lining wears, but the gap is not adjustable. The brake life indicated is the number of braking cycles after which adjustment will be required.

4. Always prepare a power supply exclusively used for the electromagnetic brake.

5. The above values are typical initial values and not guaranteed values.

6. These values are measured values and not guaranteed values.

7. Select the electromagnetic brake control relay properly, considering the characteristics of the electromagnetic brake and surge absorber.

8. Manufactured by Nippon Chemi-Con Corporation.

## 8. HA-LP SERIES

### 8.4 Servo motors with special shafts

The servo motors with special shafts indicated by the symbol (K) in the table is available. K is the symbols attached to the servo motor model names.

Servo motor	Shaft shape
	Keyway shaft (without key)
HA-LP	K

Servo motor	Variable dimensions									Figure
	S	R	Q	W	QK	QL	U	r	Y	
HA-LP502(B)K · 702(B)K · 11K2(4)(B)K HA-LP601(B)K HA-LP701M(B)K	42h6	85	80	12 <sup>0</sup> <sub>-0.04</sub>	70	5	5 <sup>+0.2</sup> <sub>0</sub>	6	Same as the straight axis of standard motor	A
HA-LP801(B)K · 12K1(B)K HA-LP11K1M(B)K · 15K1M(B)K HA-LP15K2(4)(B)K · 22K2(4)(B)K	55m6	110	100	16 <sup>0</sup> <sub>-0.04</sub>	90	5	6 <sup>+0.2</sup> <sub>0</sub>	8		
HA-LP15K1(B)K · 20K1(B)K HA-LP22K1M(B)K · 30K1M(4)(B)K HA-LP30K2(4)(B)K · 37K2(4)(B)K	60m6	140	140	18 <sup>0</sup> <sub>-0.04</sub>	128	6	7 <sup>+0.2</sup> <sub>0</sub>	9	Same as the straight axis of standard motor	B
HA-LP25K1(4)(B)K · 30K1(4)(B)K HA-LP37K1M(4)(B)K · 45K1M4(B)K HA-LP45K24(B)K · 55K24(B)K	65m6	140	140	18 <sup>0</sup> <sub>-0.04</sub>	128	6	7 <sup>+0.2</sup> <sub>0</sub>	9		
HA-LP37K1(4)(B)K HA-LP50K1M4(B)K	80m6	170	170	22 <sup>0</sup> <sub>-0.04</sub>	147	11	9 <sup>+0.2</sup> <sub>0</sub>	11		

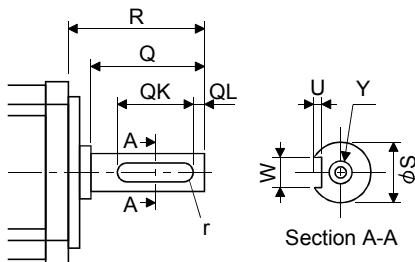

Figure A

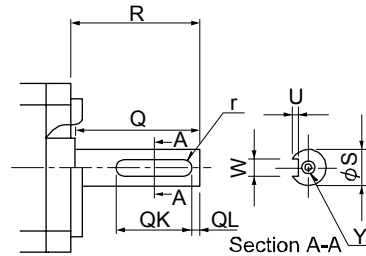

Figure B

## 8. HA-LP SERIES

### 8.5 Wiring option

Connector sets to use in power supply connector or brake connector are available as option. For details of each connector set, cable and connector set to use in wiring to encoder, refer to the Servo Amplifier Instruction Manual for using.

Make sure to use the following power supply connector set for conforming to the INC/EN compliant.

Servo motor	(Note) Power supply connector set	Brake connector set
HA-LP502	MR-PWCNS2	
HA-LP702	MR-PWCNS3	
HA-LP601 to 12K1	None (Terminal box)	MR-BKCN Configuration products Plug : MS3106A10SL-4S (D190) (DDK) Connector for cable : YSO10-5 to 8 (Daiwa Dengyo)
HA-LP701M to 15K1M		
HA-LP11K2 to 22K2		
HA-LP11K24 to 22K24		
HA-LP15K1 to 37K1		
HA-LP22K1M to 37K1M		
HA-LP30K2 * 37K2		
HA-LP15K14 to 37K14		
HA-LP22K1M4 to 50K1M4		
HA-LP30K24 to 55K24		

Note. The configuration products for power supply connector set are as shown below.

MR-PWCNS2 (Plug: CE05-6A24-10SD-D-BSS Cable clamp: CE3057-16A-2-D)

MR-PWCNS3 (Plug: CE05-6A32-17SD-D-BSS Cable clamp: CE3057-20A-1-D)

### 8.6 Cooling fan

The HA-LP servo motor have a cooling fan. Leave the following distance between the servo motor's suction face and the wall.

Servo motor series	Distance L [mm]
HA-LP601 to 12K1 HA-LP701M to 15K1M HA-LP11K2 to 22K2 HA-LP11K24 to 22K24	100
HA-LP15K1 to 37K1 HA-LP22K1M to 37K1M HA-LP30K2 * 37K2 HA-LP25K14 to 37K14 HA-LP30K1M4 to 50K1M4 HA-LP30K24 to 55K24	150

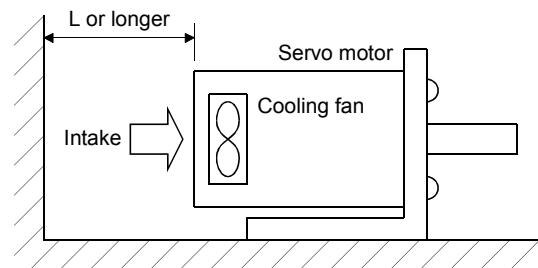

## 8. HA-LP SERIES

### 8.7 Outline dimension drawings

The dimensions without tolerances are reference dimensions.

Inertia moment on the table is the value calculated by converting the total value of inertia moment for servo motor, electromagnetic brake and decelerator with servo motor shaft.

#### 8.7.1 Terminal box detail diagram

(1) HA-LP601(4) · 701M(4) · 11K2(4)

[Unit: mm]

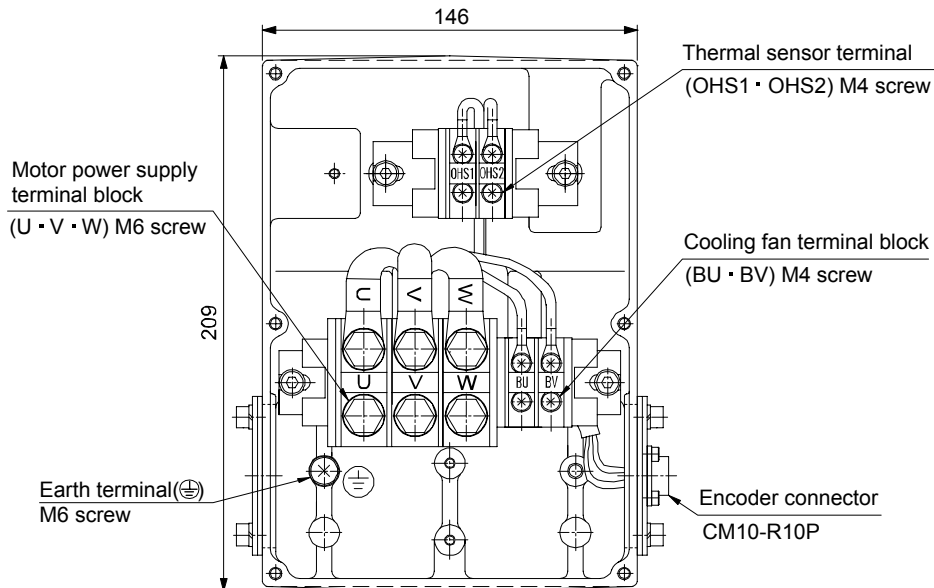

(2) HA-LP801(4) · 12K1(4) · 11K1M(4) · 15K1M(4) · 15K2(4) · 22K2(4)

[Unit: mm]

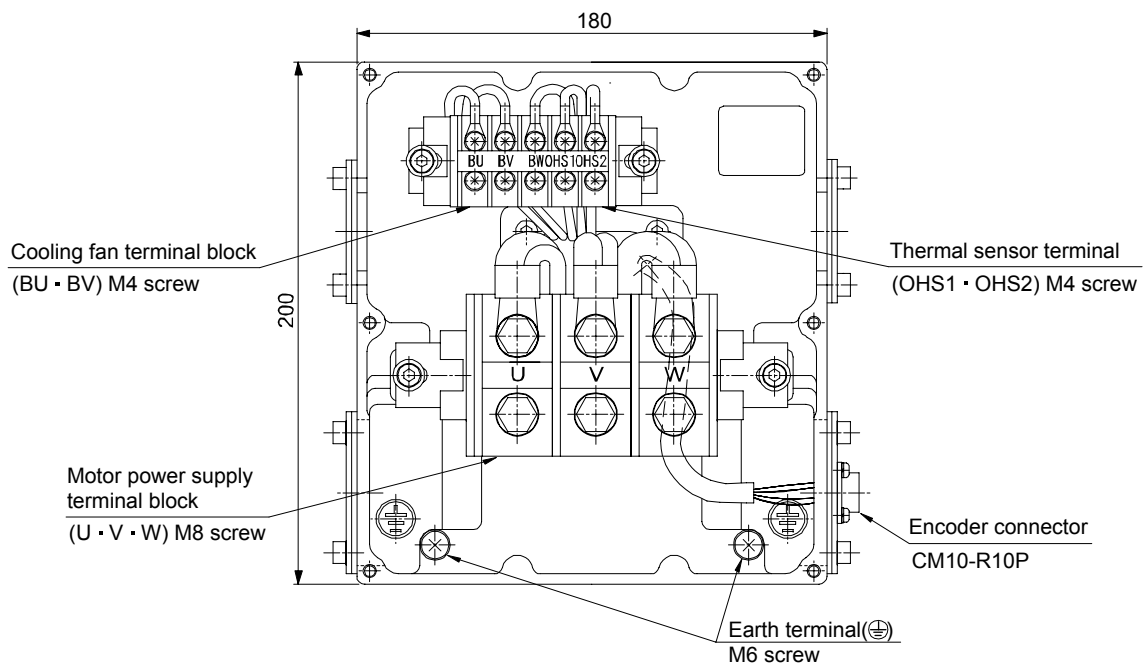

## 8. HA-LP SERIES

(3) HA-LP15K1(4) · 20K1(4) · 22K1M(4) · 30K1M4 · 30K24 · 37K24

[Unit: mm]

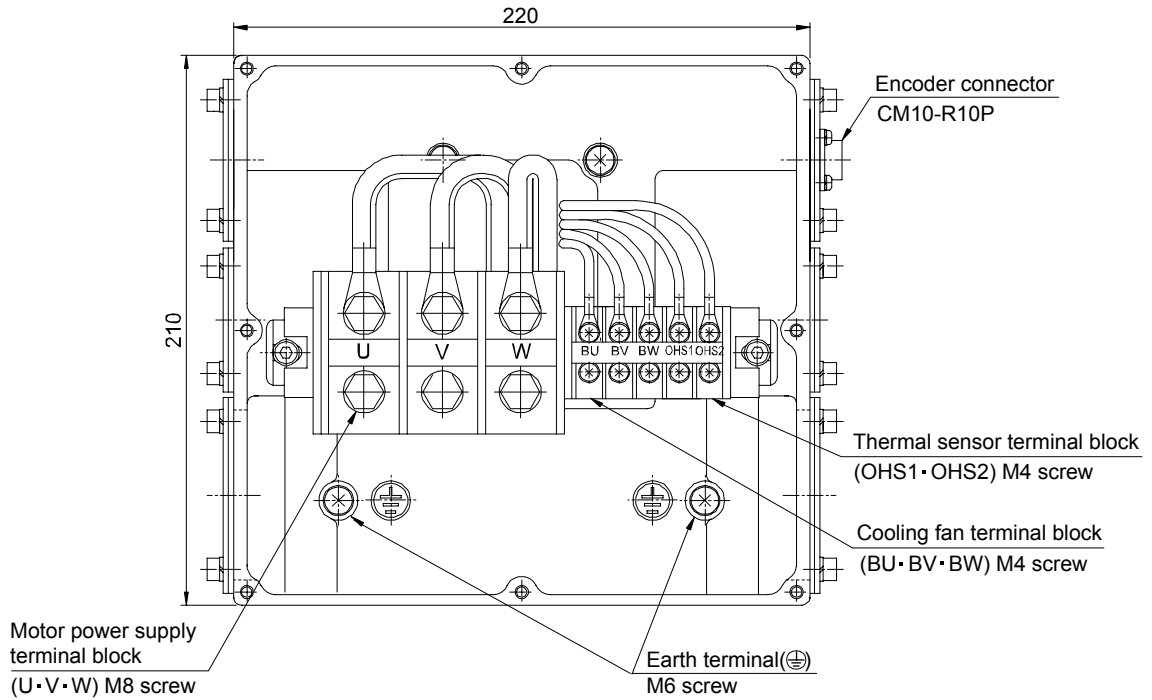

BG72622\*

(4) HA-LP25K1(4) · 30K1(4) · 37K1(4) · 30K1M(4) · 37K1M(4) · 45K1M4 · 50K1M4 · 30K2 · 37K2 · 45K24 · 55K24

[Unit: mm]

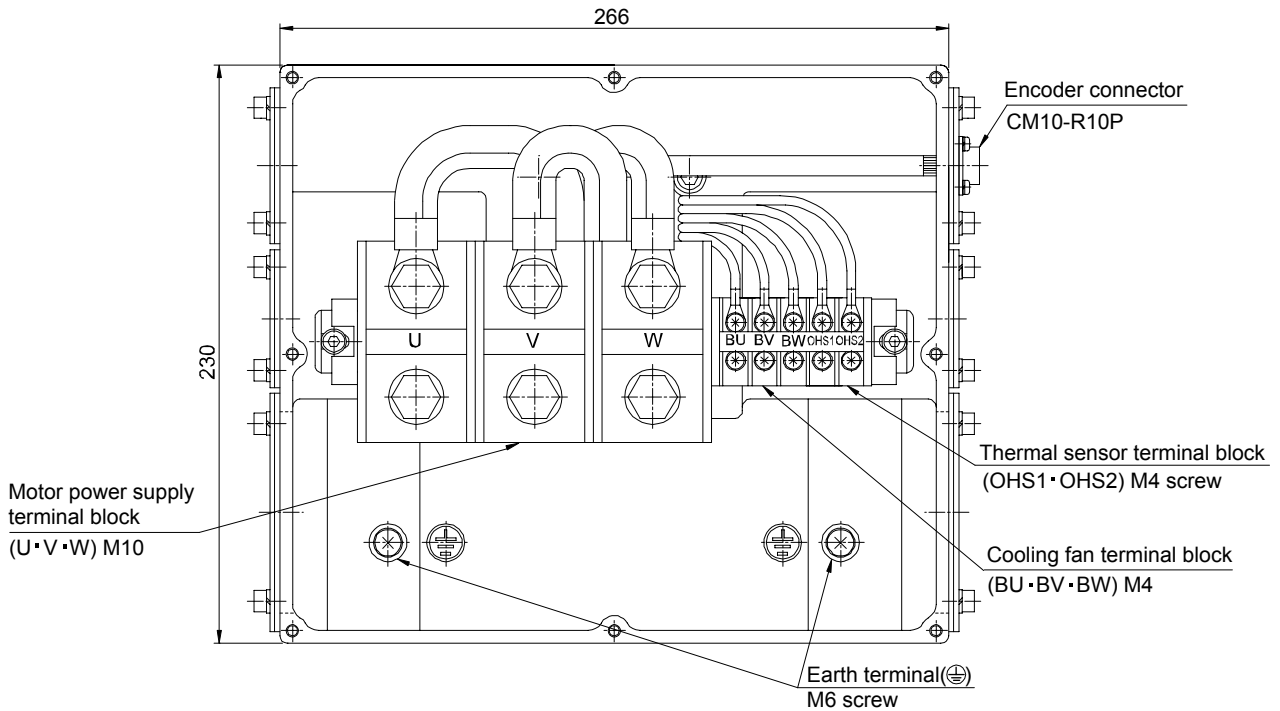

BG72623\*

## 8. HA-LP SERIES

### 8.7.2 Standard (without an electromagnetic brake)

Model	Output [kW]	Inertia moment $J [ \times 10^{-4} \text{kg} \cdot \text{m}^2 ] [ \text{WK}^2 \text{oz} \cdot \text{in}^2 ]$	Mass [kg] ([lb])
HA-LP502	5	74 (405)	28 (61.7)

[Unit: mm]

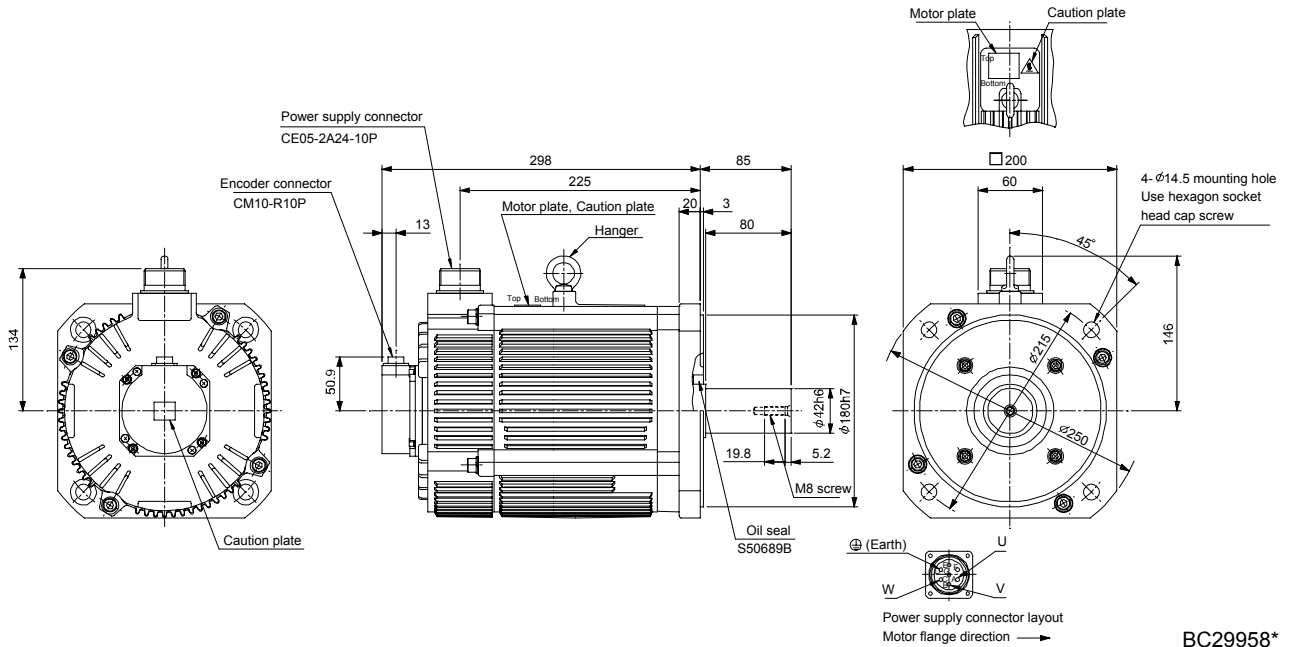

BC29958\*

Model	Output [kW]	Inertia moment $J [ \times 10^{-4} \text{kg} \cdot \text{m}^2 ] [ \text{WK}^2 \text{oz} \cdot \text{in}^2 ]$	Mass [kg] ([lb])
HA-LP702	7	94.2 (515)	35 (77.2)

[Unit: mm]

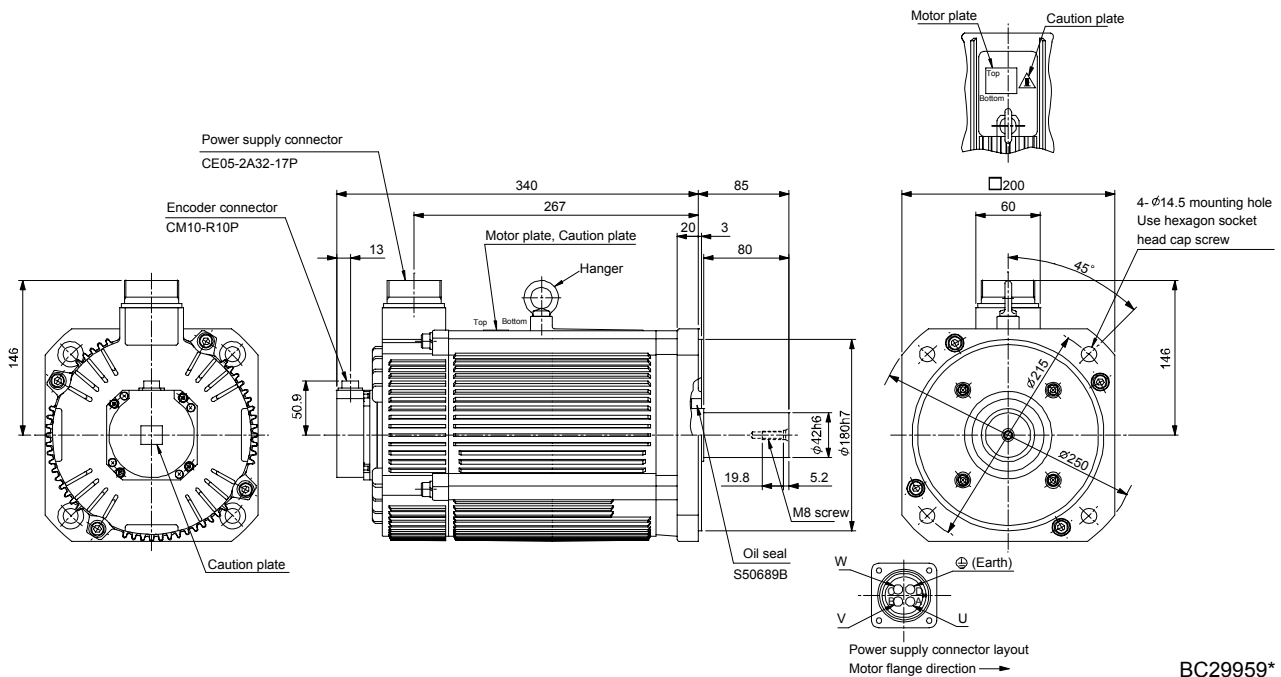

BC29959\*

## 8. HA-LP SERIES

Model	Output [kW]	Inertia moment $J [\times 10^{-4} \text{kg} \cdot \text{m}^2] (\text{WK}^2 [\text{oz} \cdot \text{in}^2])$	Mass [kg] ([lb])
HA-LP601 HA-LP6014	6	105 (574)	55 (121)
HA-LP701M HA-LP701M4	7		
HA-LP11K2 HA-LP11K24	11		

[Unit: mm]

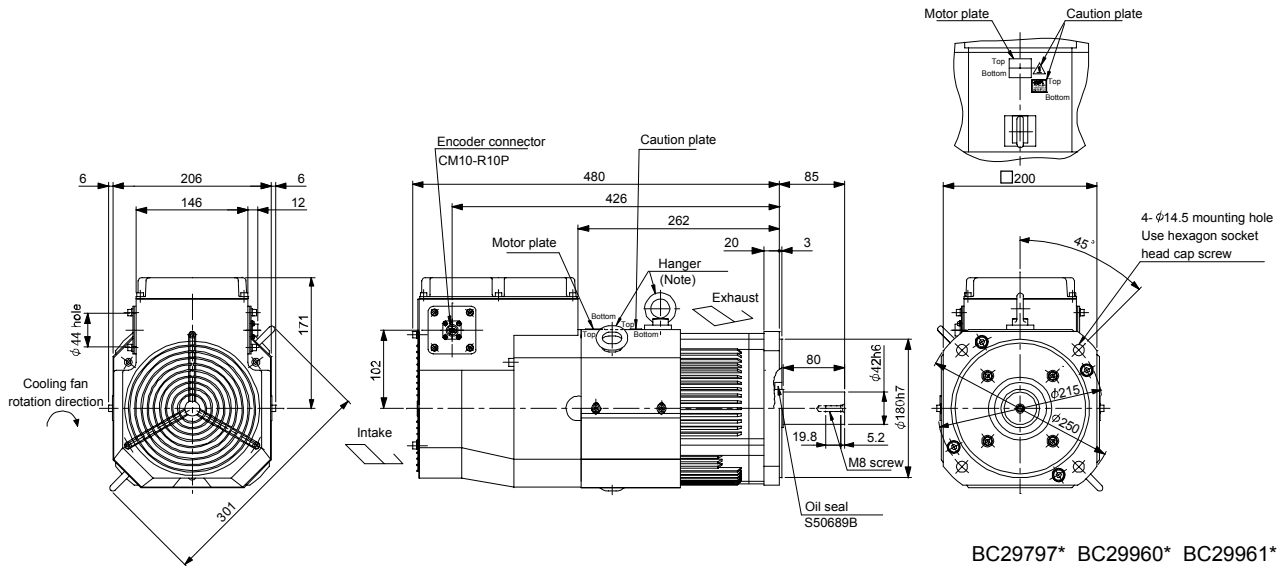

Note. When the motor is used without the hanger, plug the threaded hole with a bolt of M10 × 20 or less.

Model	Output [kW]	Inertia moment $J [\times 10^{-4} \text{kg} \cdot \text{m}^2] (\text{WK}^2 [\text{oz} \cdot \text{in}^2])$	Mass [kg] ([lb])
HA-LP801 HA-LP8014	8	220 (1200)	95 (209)
HA-LP11K1M HA-LP11K1M4	11		
HA-LP15K2 HA-LP15K24	15		

[Unit: mm]

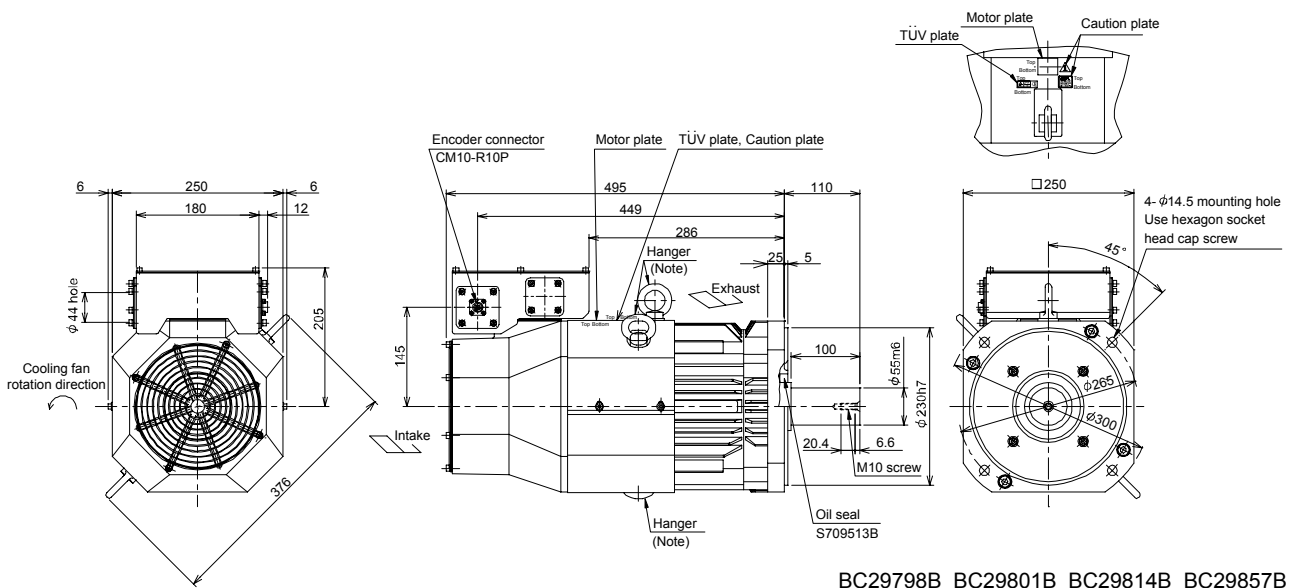

Note. When the motor is used without the hanger, plug the threaded hole with a bolt of M12 × 20 or less.

## 8. HA-LP SERIES

Model	Output [kW]	Inertia moment $J [ \times 10^{-4} \text{kg} \cdot \text{m}^2 ] ( \text{WK}^2 [ \text{oz} \cdot \text{in}^2 ] )$	Mass [kg] ([lb])
HA-LP12K1 HA-LP12K14	12	295 (1610)	115 (254)
HA-LP15K1M HA-LP15K1M4	15		
HA-LP22K2 HA-LP22K24	22		

[Unit: mm]

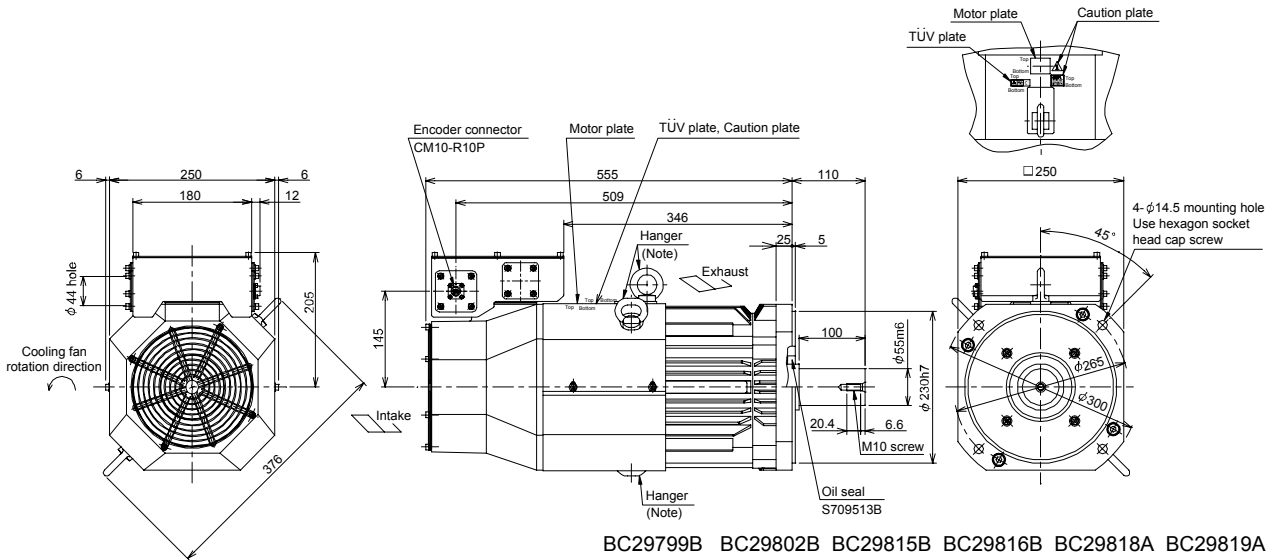

Note. When the motor is used without the hanger, plug the threaded hole with a bolt of  $M12 \times 20$  or less.

Model	Output [kW]	Inertia moment $J [ \times 10^{-4} \text{kg} \cdot \text{m}^2 ] ( \text{WK}^2 [ \text{oz} \cdot \text{in}^2 ] )$	Mass [kg] ([lb])
HA-LP15K1 HA-LP15K14	15	550 (3010)	160 (353)
HA-LP22K1M HA-LP22K1M4	22		
HA-LP30K24	30		

[Unit: mm]

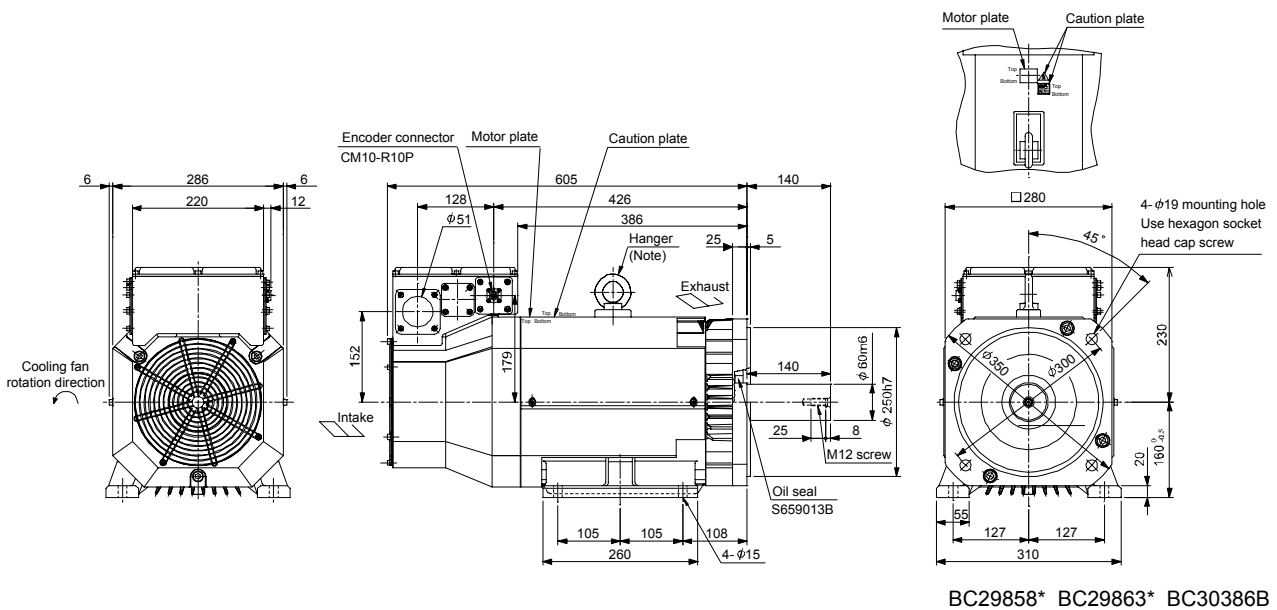

Note. When the motor is used without the hanger, plug the threaded hole with a bolt of  $M16 \times 20$  or less.



## 8. HA-LP SERIES

Model	Output [kW]	Inertia moment $J [ \times 10^{-4} \text{kg} \cdot \text{m}^2 ] ( \text{WK}^2 [\text{oz} \cdot \text{in}^2] )$	Mass [kg] (lb)
HA-LP20K1 HA-LP20K14	20	650 (3550)	180 (397)
HA-LP30K1M4	30		
HA-LP37K24	37		

[Unit: mm]

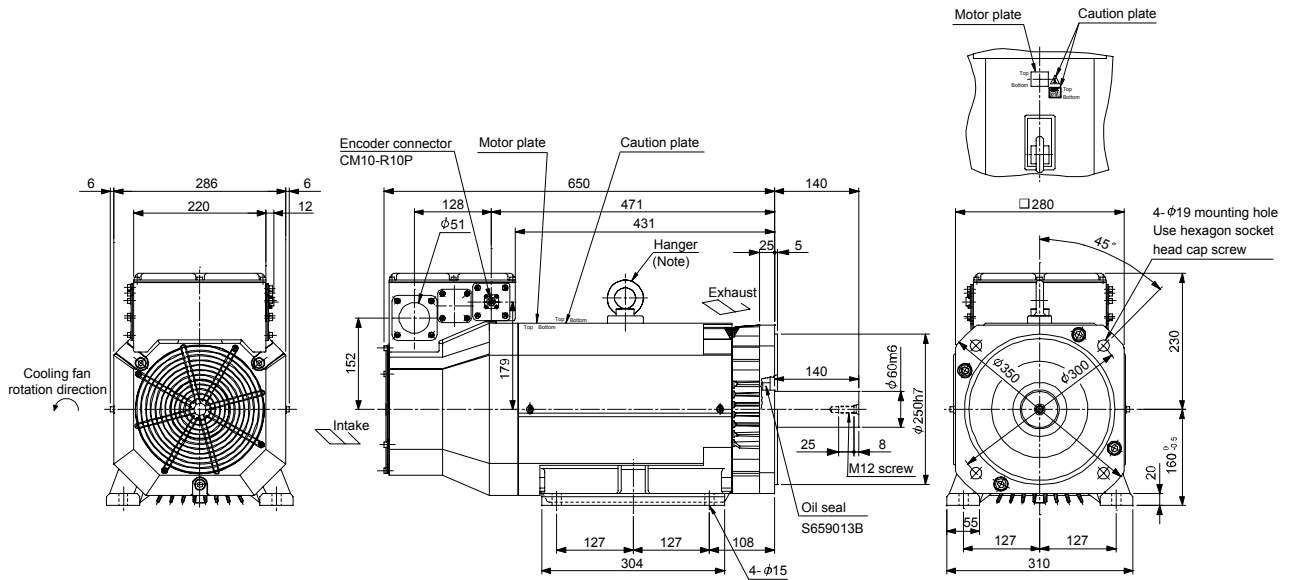

BC29864\* BC30384\* BC30388B

Note. When the motor is used without the hanger, plug the threaded hole with a bolt of M16 × 20 or less.

Model	Output [kW]	Inertia moment $J [ \times 10^{-4} \text{kg} \cdot \text{m}^2 ] ( \text{WK}^2 [\text{oz} \cdot \text{in}^2] )$	Mass [kg] (lb)
HA-LP25K1 HA-LP25K14	25	1080 (5900)	230 (507)
HA-LP37K1M HA-LP37K1M4	37		
HA-LP45K24	45		

[Unit: mm]

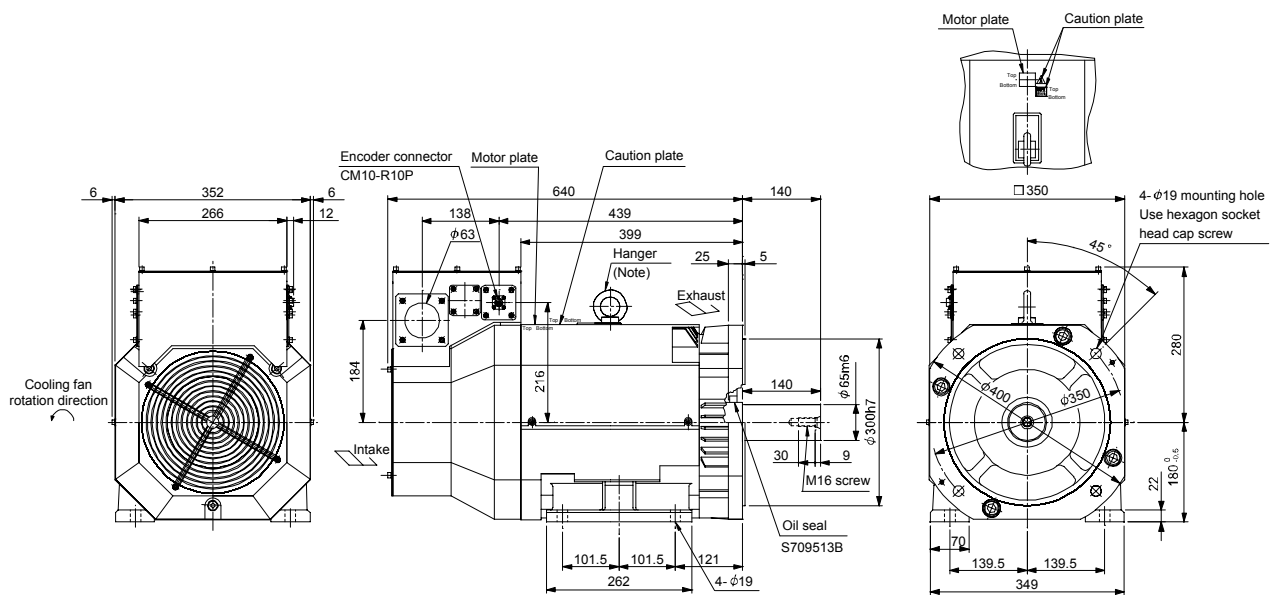

BC29865\* BC30394\* BC30397B

Note. When the motor is used without the hanger, plug the threaded hole with a bolt of M16 × 20 or less.

## 8. HA-LP SERIES

Model	Output [kW]	Inertia moment $J [ \times 10^{-4} \text{kg} \cdot \text{m}^2 ] ( \text{WK}^2 [ \text{oz} \cdot \text{in}^2 ] )$	Mass [kg] ([lb])
HA-LP30K1 HA-LP30K14	30	1310 (7160)	250 (551)
HA-LP45K1M4	45		
HA-LP55K24	55		

[Unit: mm]

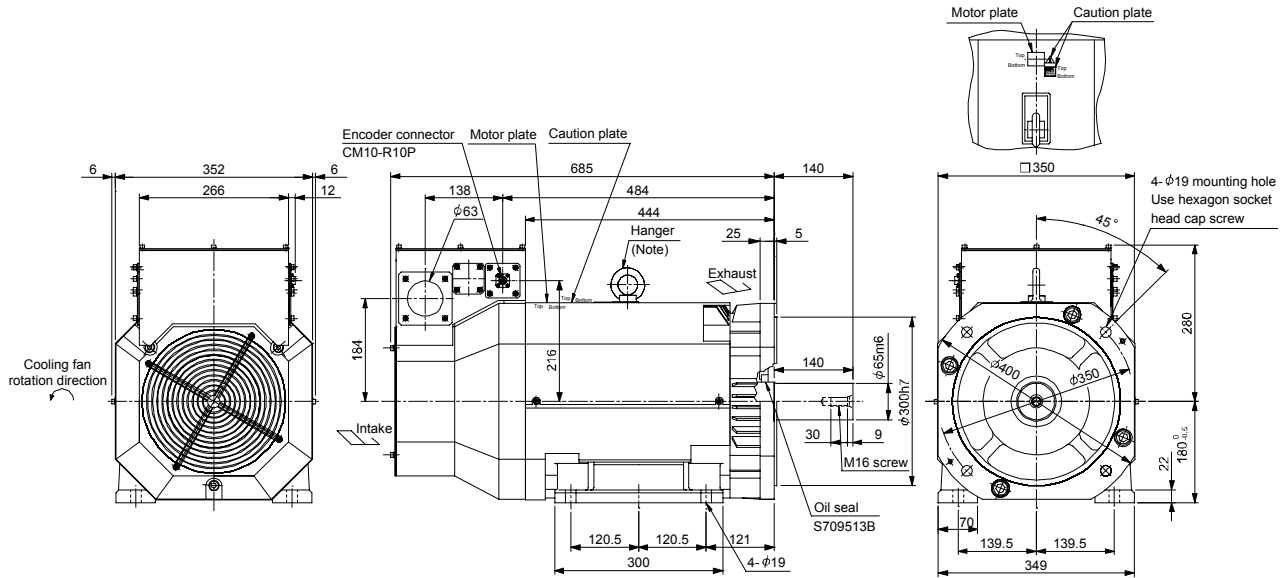

BC30390\* BC30396\* BC30399B

Note. When the motor is used without the hanger, plug the threaded hole with a bolt of M12 × 20 or less.

Model	Output [kW]	Inertia moment $J [ \times 10^{-4} \text{kg} \cdot \text{m}^2 ] ( \text{WK}^2 [ \text{oz} \cdot \text{in}^2 ] )$	Mass [kg] ([lb])
HA-LP37K1 HA-LP37K14	37	1870 (10200)	335 (739)
HA-LP50K1M4	50		

[Unit: mm]

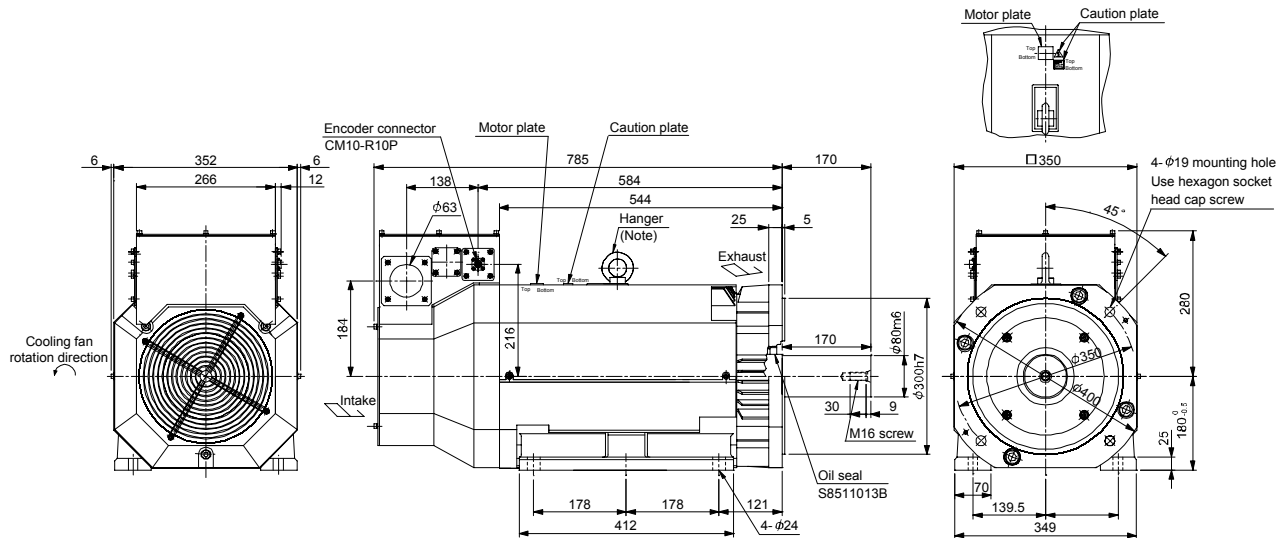

BC30392\* BC30398B

Note. When the motor is used without the hanger, plug the threaded hole with a bolt of M16 × 20 or less.

## 8. HA-LP SERIES

Model	Output [kW]	Inertia moment $J [ \times 10^{-4} \text{kg} \cdot \text{m}^2 ] ( \text{WK}^2 [ \text{oz} \cdot \text{in}^2 ] )$	Mass [kg] (lb)
HA-LP30K1M	30	650 (3550)	180 (397)
HA-LP37K2	37		

[Unit: mm]

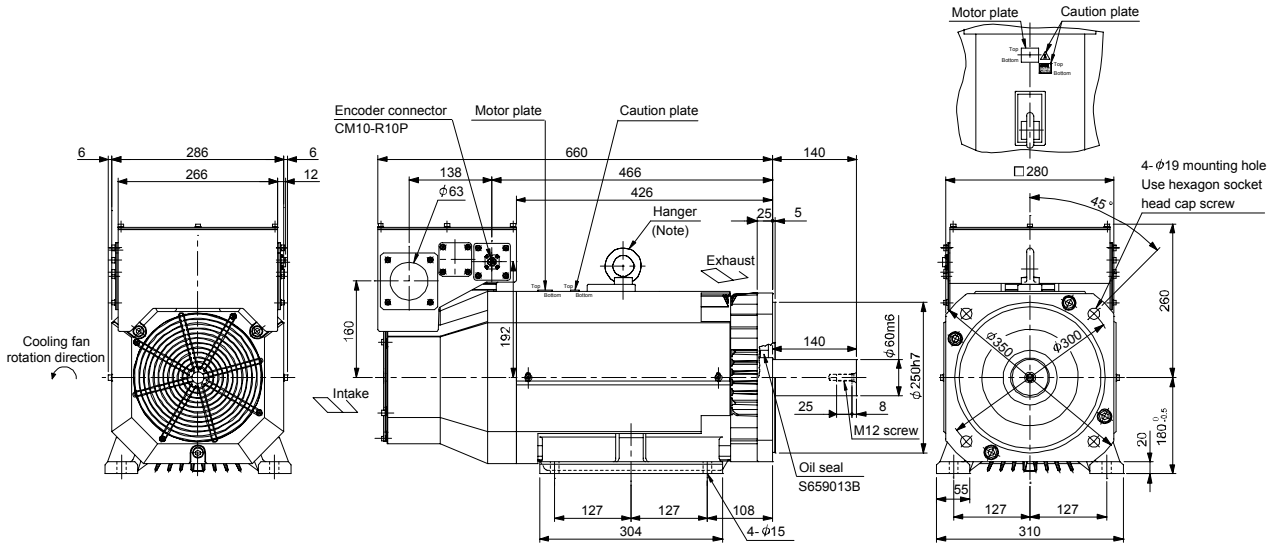

Note. When the motor is used without the hanger, plug the threaded hole with a bolt of  $M10 \times 20$  or less.

Model	Output [kW]	Inertia moment $J [ \times 10^{-4} \text{kg} \cdot \text{m}^2 ] ( \text{WK}^2 [ \text{oz} \cdot \text{in}^2 ] )$	Mass [kg] (lb)
HA-LP30K2	30	550 (3010)	160 (353)

[Unit: mm]

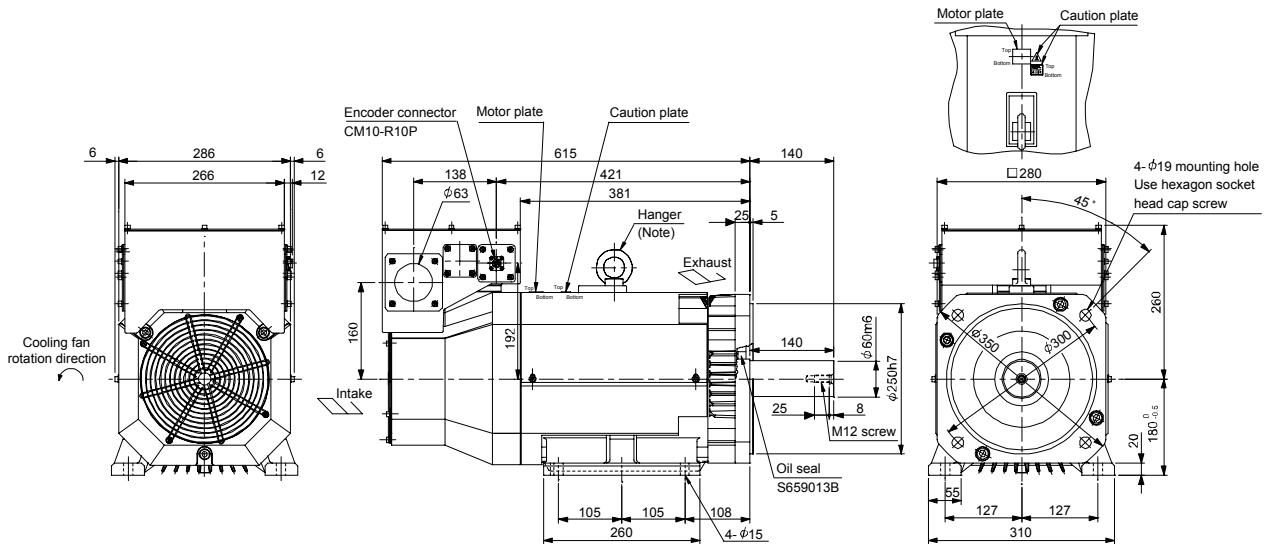

Note. When the motor is used without the hanger, plug the threaded hole with a bolt of  $M12 \times 20$  or less.

## 8. HA-LP SERIES

### 8.7.3 With an electromagnetic brake

Model	Output [kW]	Brake static friction torque [N · m] (oz · in)	Inertia moment $J [ \times 10^{-4} \text{kg} \cdot \text{m}^2 ] (\text{WK}^2 \text{oz} \cdot \text{in}^2)$	Mass [kg] (lb)
HA-LP601B HA-LP6014B	6	82 (11600)	113 (618)	70 (154)
HA-LP701MB HA-LP701M4B	7			
HA-LP11K2B HA-LP11K24B	11			

[Unit: mm]

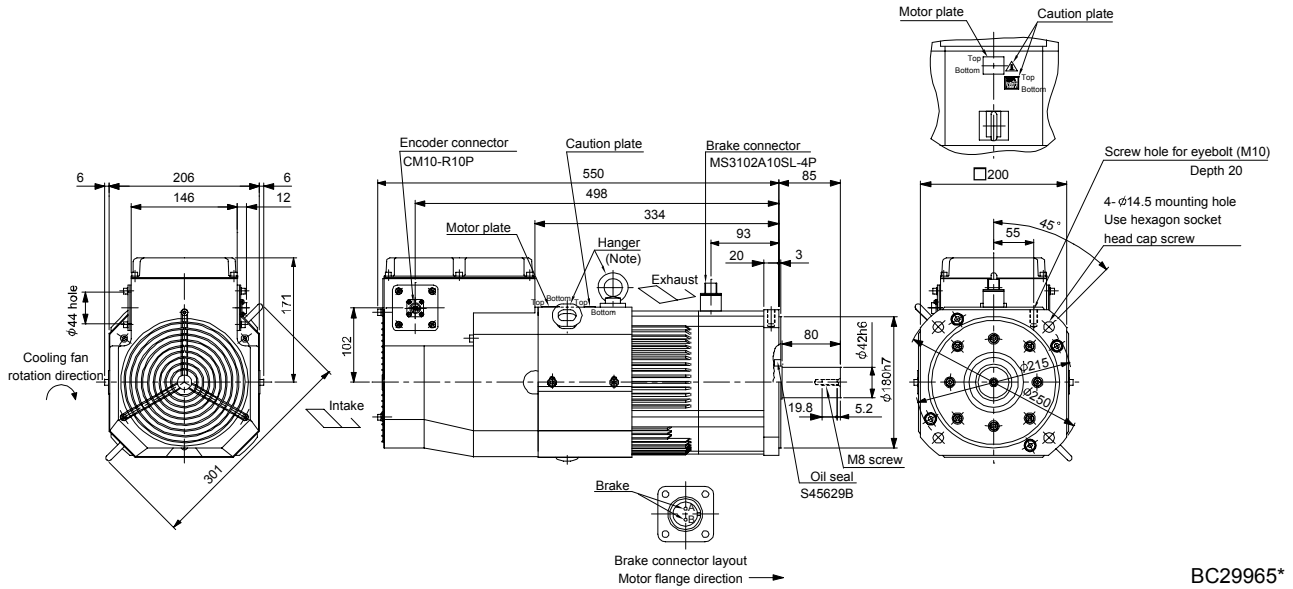

Note. When the motor is used without the hanger, plug the threaded hole with a bolt of  $M10 \times 20$  or less.

Model	Output [kW]	Brake static friction torque [N · m] (oz · in)	Inertia moment $J [ \times 10^{-4} \text{kg} \cdot \text{m}^2 ] (\text{WK}^2 \text{oz} \cdot \text{in}^2)$	Mass [kg] (lb)
HA-LP801B HA-LP8014B	8	160.5 (22700)	293 (1600)	130 (287)
HA-LP11K1MB HA-LP11K1M4B	11			
HA-LP15K2B HA-LP15K24B	15			

[Unit: mm]

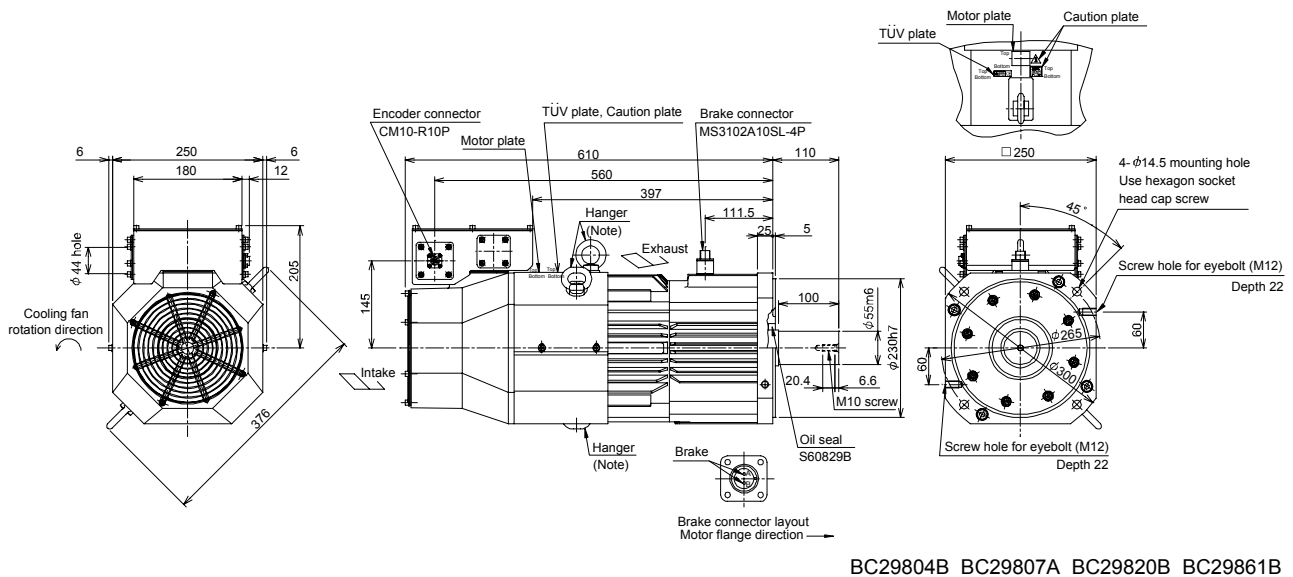

Note. When the motor is used without the hanger, plug the threaded hole with a bolt of  $M12 \times 20$  or less.

## 8. HA-LP SERIES

Model	Output [kW]	Brake static friction torque [N · m] [(oz · in)]	Inertia moment $J [ \times 10^{-4} \text{kg} \cdot \text{m}^2 ] (\text{WK}^2 [\text{oz} \cdot \text{in}^2])$	Mass [kg] [(lb)]
HA-LP12K1B HA-LP12K14B	12	160.5 (22700)	369 (2020)	150 (331)
HA-LP15K1MB HA-LP15K1M4B	15			
HA-LP22K2B HA-LP22K24B	22			

[Unit: mm]

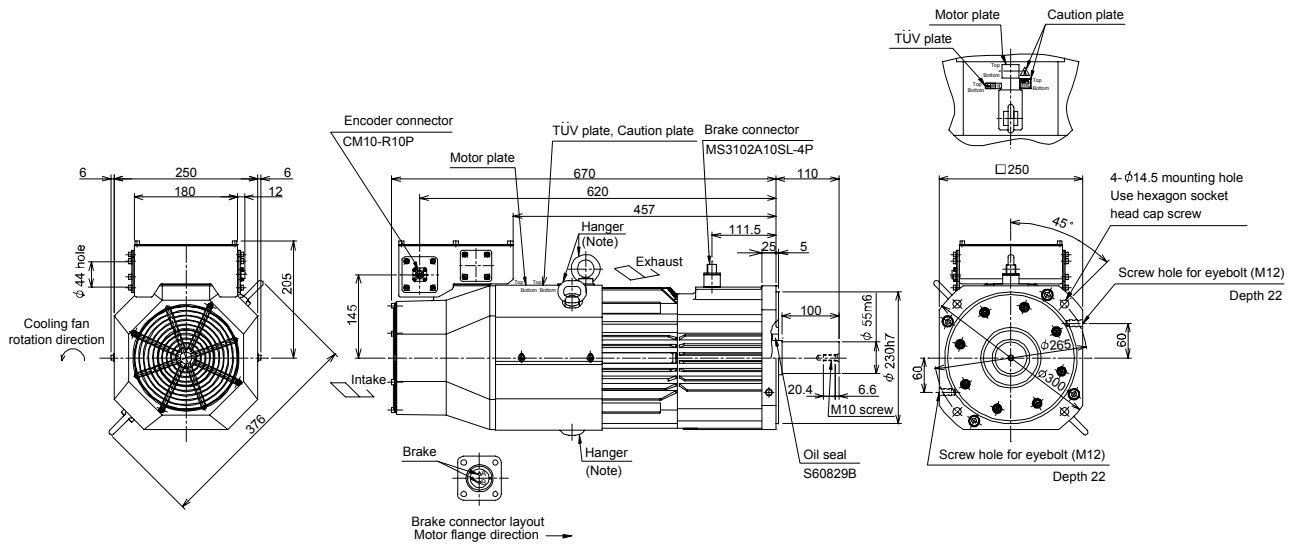

BC29805B BC29808A BC29821B BC29822B BC29824B BC29825A

Note. When the motor is used without the hanger, plug the threaded hole with a bolt of M12 × 20 or less.

### 8.8 Servo motor with oil seal

For the servo motor with oil seal, the oil seal prevents the entry of oil into the servo motor. Install the servo motor horizontally, and set the oil level in the gear box to be lower than the oil seal lip always.

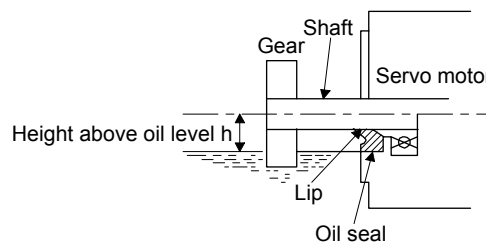

Servo motor	Height above oil level h [mm]
HA-LP502 · 702 · 601(4) HA-LP701M(4) · 11K2(4)	34
HA-LP15K1(4) · 20K1(4) HA-LP22K1M(4) · 30K1M(4) HA-LP30K2(4) · 37K2(4)	45
HA-LP801(4) · 12K1(4) · 25K1(4) · 30K1(4) HA-LP11K1M(4) · 15K1M(4) · 37K1M(4) · 45K1M4 HA-LP15K2(4) · 22K2(4) · 45K24 · 55K24	48
HA-LP37K1(4) · 50K1M4	55

# 9. HC-RP SERIES

## 9. HC-RP SERIES

This chapter provides information on the servo motor specifications and characteristics. When using the HC-RP series servo motor, always read the Safety Instructions in the beginning of this manual and chapters 1 to 4, in addition to this chapter.

### 9.1 Model name make up

The following describes what each block of a model name indicates. Note that not all the combinations of the symbols exist.

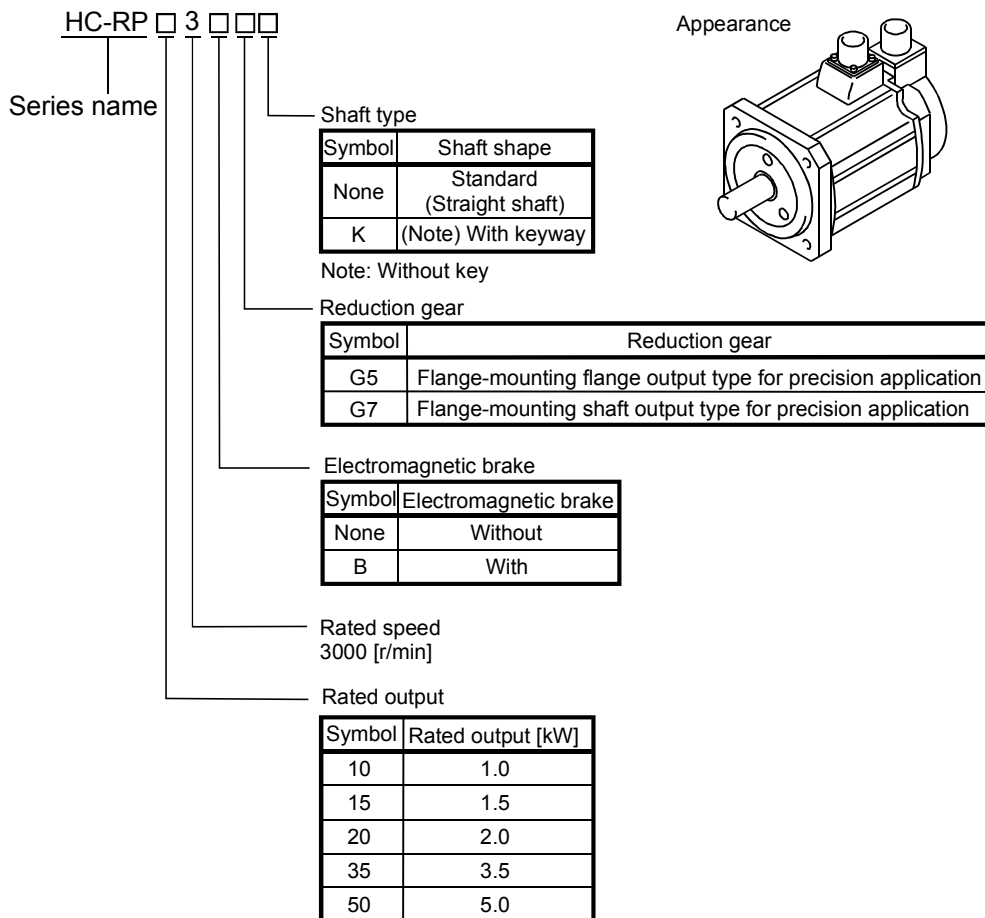

## 9. HC-RP SERIES

### 9.2 Standard specifications

#### 9.2.1 Standard specifications list

Item		Servo motor		HC-RP series (Low inertia · middle capacity)				
				103	153	203	353	503
Applicable servo amplifier/drive unit	MR-J3-□A/B/B-RJ006/T			200	200	350	500	500
Continuous running duty (Note 1)	Rated output	[kW]		1.0	1.5	2.0	3.5	5.0
	Rated torque	[N · m]		3.18	4.78	6.37	11.1	15.9
		[oz · in]		450	677	902	1570	2250
Rated speed (Note 1)	[r/min]			3000				
Maximum speed	[r/min]			4500				
Instantaneous permissible speed	[r/min]			5175				
Maximum torque	[N · m]		7.95	11.9	15.9	27.9	39.7	
	[oz · in]		1130	1690	2250	3950	5620	
Power rate at continuous rated torque	[kW/s]		67.4	120	176	150	211	
Inertia moment (Note 3)	J	[× 10 <sup>-4</sup> kg · m <sup>2</sup> ]		1.5	1.9	2.3	8.3	12.0
	WK <sup>2</sup>	[oz · in <sup>2</sup> ]		8.2	10.4	12.6	45.4	65.6
Recommended ratio of load inertia moment to servo motor shaft inertia moment (Note 2)				5 times or less				
Power supply capacity				Refer to "Power supply equipment capacity and generated loss of servo amplifiers" in Servo Amplifier Instruction Manual.				
Rated current	[A]		6.1	8.8	14	23	28	
Maximum current	[A]		18	23	37	58	70	
Speed/position detector				Encoder common to absolute position and incremental detection systems (Resolution per servo motor 1 rotation: 262144 pulse/rev)				
Accessory				Oil seal				
Insulation class				155(F)				
Structure				Totally-enclosed, natural-cooling (IP rating: IP65 (Note 4, 9))				
Environmental conditions (Note 5)	Ambient temperature	Operation	[°C]	0 to 40 (non-freezing)				
			[°F]	32 to 104 (non-freezing)				
		Storage	[°C]	-15 to 70 (non-freezing)				
			[°F]	5 to 158 (non-freezing)				
	Ambient humidity	Operation		80%RH or less (non-condensing)				
		Storage		90%RH or less (non-condensing)				
	Ambience		Indoors (no direct sunlight) Free from corrosive gas, flammable gas, oil mist, dust and dirt.					
	Altitude		Max.1000m above sea level					
Vibration resistance (Note 6)		[m/s <sup>2</sup> ]	X, Y: 24.5					
Vibration rank (Note 7)				V10				
Permissible load for the shaft (Note 8)	L		[mm]	45			63	
	Radial	[N]		686			980	
		[lb]		154			220	
	Thrust	[N]		196			392	
		[lb]		44.1			88.1	
Mass (Note 3)	[kg]		3.9	5.0	6.2	12	17	
	[lb]		8.6	11.0	13.7	26.5	37.5	

## 9. HC-RP SERIES

Note 1. When the power supply voltage drops, we cannot guarantee the out put and rated speed.

2. If the load inertia moment ratio exceeds the indicated value, please consult your local sales office.
3. Refer to the outline dimension drawing for the servo motor with an electromagnetic brake.
4. Except for the shaft – through portion.
5. In the environment where the servo motor is exposed to oil mist, oil and/or water, the servo motor of the standard specifications may not be usable. Contact your local sales office.
6. The vibration direction is as shown in the figure. The value is the one at the part that indicates the maximum value (normally the opposite-to-load side bracket). When the servo motor stops, fretting is likely to occur at the bearing. Therefore, suppress the vibration to about half of the permissible value.

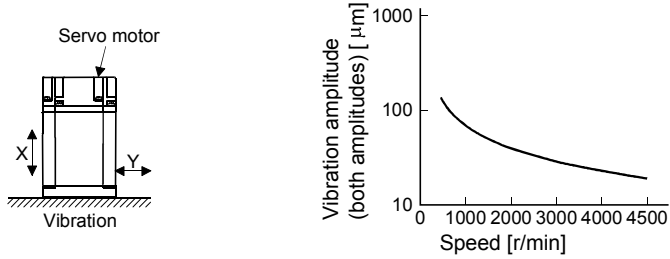

7. V10 indicates that the amplitude of a single servo motor is 10μm or less. The following figure shows the servo motor installation position for measurement and the measuring position.

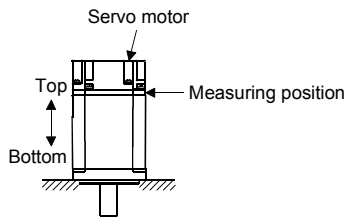

8. For the symbols in the table, refer to the following diagram: Do not subject the shaft to load greater than this value.  
The values in the table assume that the loads work singly.

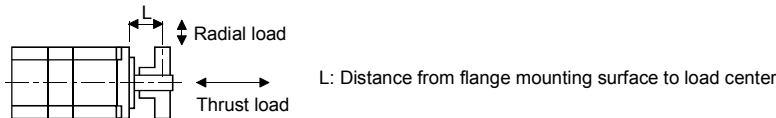

9. When the servo motor is provided with the reduction gear, the IP rating of the reduction gear section is IP44.



## 9. HC-RP SERIES

### 9.2.2 Torque characteristics

<b>POINT</b>
<ul style="list-style-type: none"> <li>For machines which produce unbalance torque, e.g. vertical lift applications, it is recommended to use the servo motor so that the unbalance torque will be within 70% of the rated torque.</li> </ul>

When the power input of the servo amplifier is 3-phase 200VAC, the torque characteristic is indicated by the thin line.

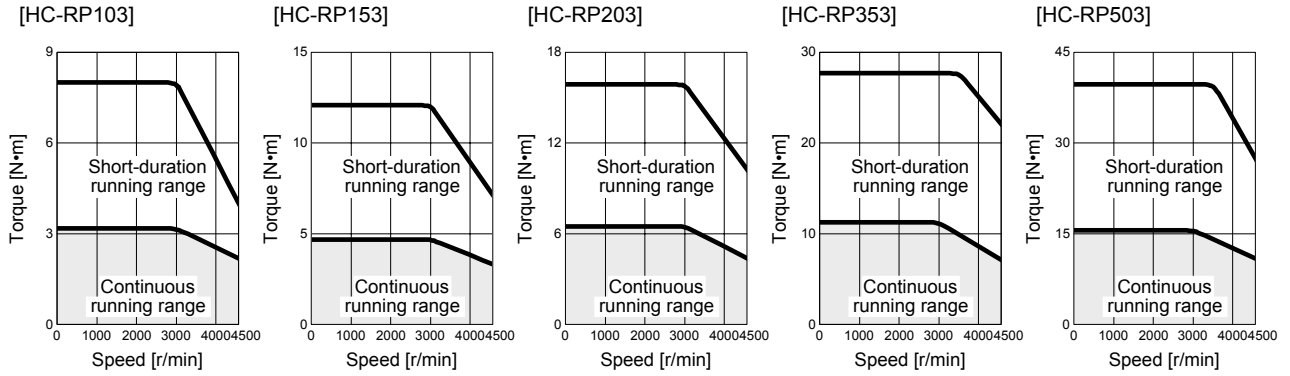

## 9. HC-RP SERIES

### 9.3 Electromagnetic brake



**CAUTION**

- The electromagnetic brake is provided to prevent a drop at a power failure or servo alarm occurrence during vertical drive or to hold a shaft at a stop. Do not use it for normal braking (including braking at servo lock).
- Before performing the operation, be sure to confirm that the electromagnetic brake operates properly.
- The operation time of the electromagnetic brake differs depending on the power supply circuit you use. Be sure to check the operation delay time with a real machine.

The characteristics of the electromagnetic brake provided for the servo motor with an electromagnetic brake are indicated below.

Item	Servo motor	HC-RP series	
		103B to 203B	353B · 503B
Type (Note 1)		Spring-loaded safety brake	
Rated voltage (Note 4)		24V <sup>0</sup> <sub>-10%</sub> DC	
Capacity	[W] at 20°C (68°F)	19	23
Coil resistance (Note 6)	[Ω]	30.0	25
Inductance (Note 6)	[H]	0.81	0.70
Brake static friction torque	[N · m]	7	17
	[oz · in]	991	2410
Release delay time (Note 2)	[s]	0.03	0.04
Braking delay time (Note 2)	[s] DC off	0.03	0.03
Permissible braking work	Per braking [J]	400	400
	Per hour [J]	4000	4000
Brake looseness at servo motor shaft (Note 5)	[degrees]	0.2 to 0.6	0.2 to 0.6
Brake life (Note 3)	Number of braking cycles [times]	20000	20000
	Work per braking [J]	200	200
Selection example of surge absorbers to be used (Note 7, 8)	For the suppressed voltage 125V	TND20V-680KB	
	For the suppressed voltage 350V	TND10V-221KB	

Note 1. There is no manual release mechanism. When it is necessary to hand-turn the servo motor shaft for machine centering, etc., use a separate 24VDC power supply to release the brake electrically.

2. The value for initial ON gap at 20°C (68°F).

3. The brake gap will increase as the brake lining wears, but the gap is not adjustable. The brake life indicated is the number of braking cycles after which adjustment will be required.

4. Always prepare a power supply exclusively used for the electromagnetic brake.

5. The above values are typical initial values and not guaranteed values.

6. These values are measured values and not guaranteed values.

7. Select the electromagnetic brake control relay properly, considering the characteristics of the electromagnetic brake and surge absorber.

8. Manufactured by Nippon Chemi-Con Corporation.

## 9. HC-RP SERIES

### 9.4 Servo motors with special shafts

The servo motors with special shafts indicated by the symbol (K) in the table is available. K is the symbols attached to the servo motor model names.

Servo motor	Shaft shape
	Keyway shaft (without key)
HC-RP	K

Servo motor	Variable dimensions							
	S	R	Q	W	QK	QL	U	r
HC-RP103(B)K to 203(B)K	24h6	45	40	$8^{0}_{-0.036}$	25	5	$4^{+0.2}_{0}$	4
HC-RP353(B)K to 503(B)K	28h6	63	58	$8^{0}_{-0.036}$	53	3	$4^{+0.2}_{0}$	4

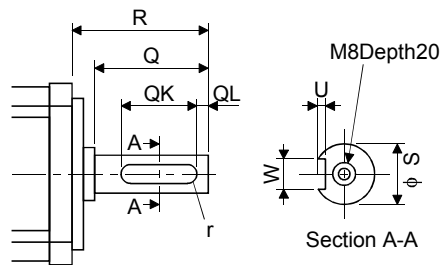

## 9. HC-RP SERIES

### 9.5 Servo motors with a reduction gear for precision application compliant (G5/G7)



**CAUTION**

- The servo motor with a reduction gear must be installed in the specified direction. Otherwise, it can leak oil, leading to a fire or fault.
- For the servo motor with a reduction gear, transport it in the same status as in the installation method. Tipping it over can cause oil leakage.

Servo motors are available with a reduction gear designed for: precision applications compliant.  
Servo motors with an electromagnetic brake are also available.

#### (1) Manufacturing range

The symbols (20A, 32A, 50A) in the following table indicate the model numbers of the reduction gears assembled to the servo motors.

Servo motors with a reduction gear having the indicated reduction gear model numbers are available.

The reduction gear model number indicates □□□ of the reduction number model name HPG-□□□-05...

Servo motor	Reduction ratio				
	1/5	1/11	1/21	1/33	1/45
HC-RP103(B)G5 HC-RP103(B)G7					
HC-RP153(B)G5 HC-RP153(B)G7	20A	32A			
HC-RP203(B)G5 HC-RP203(B)G7				50A	
HC-RP353(B)G5 HC-RP353(B)G7					
HC-RP503(B)G5 HC-RP503(B)G7					

#### (2) Specifications

Item	Description
Mounting method	Flange mounting
Mounting direction	In any directions
Lubrication method	Grease lubrication (Already packed) (Note 1)
	Packed with Reduction gear model number 20A, 32A: Harmonic grease SK-2 (Harmonic Drive Systems) Reduction gear model number 50A: EPNOC grease AP(N)2 (JX Nippon Oil & Energy)
Output shaft rotating direction	Same as the servo motor output shaft direction.
With an electromagnetic brake	Available
Backlash	3 minutes or less at reduction gear output shaft
Permissible load inertia moment ratio (when converting into the servo motor shaft) (Note 2)	5 times or less
Permissible speed (at servo motor shaft)	4500r/min
IP rating (reduction gear area)	IP44 equivalent
Reduction gear efficiency (Note 3)	71 to 90%

Note 1. Already packed with grease.

2. If the above indicated value is exceeded, please consult your local sales office.

3. The reduction gear efficiency differs depending on the reduction ratio.

Also, it changes depending on the use conditions such as the output torque, speed and rotation, temperature, etc.

The numerical value in the table is a typical value in the rated torque, rated speed and rotation and typical temperature, and not a guaranteed value.

## 9. HC-RP SERIES

### (3) Permissible loads of servo motor shaft

The radial load point of a precision reduction gear is as shown below.

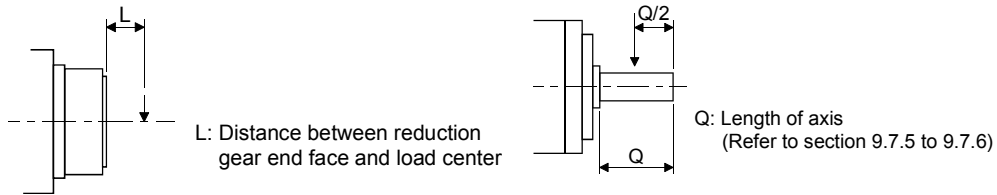

Flange-mounting flange output type for precision application compliant (G5)

Flange-mounting shaft output type for precision application compliant (G7)

Servo motor	Reduction ratio	Radial load point L (mm)	Permissible load (Note)			
			Permissible radial load		Permissible thrust load	
			[N]	[lb]	[N]	[lb]
HC-RP103(B)G5 HC-RP103(B)G7	1/5	32	416	93.5	1465	329.3
	1/11	32	527	118	1856	417
	1/21	57	1094	246	4359	980
	1/33	57	1252	282	4992	1120
	1/45	57	1374	309	5478	1230
HC-RP153(B)G5 HC-RP153(B)G7	1/5	32	416	93.5	1465	329
	1/11	57	901	203	3590	807
	1/21	57	1094	246	4359	980
	1/33	62	2929	658	10130	2280
	1/45	62	3215	723	11117	2500
HC-RP203(B)G5 HC-RP203(B)G7	1/5	32	416	93.5	1465	329
	1/11	57	901	203	3590	807
	1/21	62	2558	575	8845	1990
	1/33	62	2929	658	10130	2280
	1/45	62	3215	723	11117	2500
HC-RP353(B)G5 HC-RP353(B)G7	1/5	57	711	160	2834	637
	1/11	57	901	203	3590	807
	1/21	62	2558	575	8845	1990
	1/33	62	2929	658	10130	2280
HC-RP503(B)G5 HC-RP503(B)G7	1/5	57	711	160	2834	637
	1/11	62	2107	474	7285	1640
	1/21	62	2558	575	8845	1990

Note. The load above this value should not be applied to the shaft.  
The value in the table assumes that the load is applied independently.

## 9. HC-RP SERIES

### (4) Special shaft servo motors

Servo motors with special shafts having keyway (with single pointed keys) are available for the flange-mounting shaft output type for precision applications compliant (G7).

[Unit: mm]

Servo motor	Reduction gear model number	Q	$\phi S$	W	T	QK	U	Y
HF-RFS□(B)G7K	20A	42	25h7	8	7	36	4	M6 Depth 12
	32A	82	40h7	12	8	70	5	M10
	50A	82	40h7	14	9	70	5.5	Depth 20

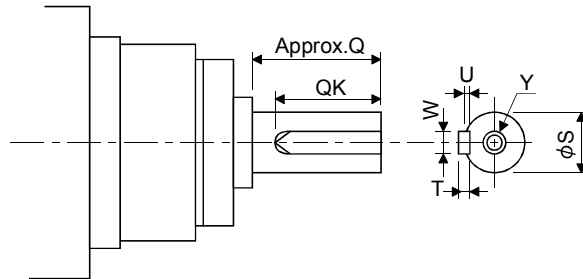

### 9.6 Wiring option

Connector sets to use in power supply connector or brake connector are available as option.

For details of each connector set, cable and connector set to use in wiring to encoder, refer to the Servo Amplifier Instruction Manual for using.

Make sure to use the following power supply connector set for conforming to the IEC/EN compliant.

Servo motor	Power supply connector set	Brake connector set
HC-RP103 to 203	MR-PWCNS1 Configuration products Plug : CE05-6A22-23SD-D-BSS Cable clamp : CE3057-12A-2-D (DDK)	Shared with the one for power supply (Note)
HC-RP353 * 503	MR-PWCNS2 Configuration products Plug : CE05-6A24-10SD-D-BSS Cable clamp : CE3057-16A-2-D (DDK)	

Note. Brake connector is not required since the power supply connector has a pin assigned for electromagnetic brake.

## 9. HC-RP SERIES

### 9.7 Outline dimension drawings

The dimensions without tolerances are reference dimensions.

The outer frame of the reduction gear is a material surface such as casting. Its actual dimensions may be 1 to 3mm larger than the drawing dimensions. Design the machine side with allowances.

Inertia moment on the table is the value calculated by converting the total value of inertia moment for servo motor, electromagnetic brake and decelerator with servo motor shaft.

#### 9.7.1 Standard (without an electromagnetic brake)

Model	Output [kW]	Inertia moment $J [\times 10^{-4} \text{kg} \cdot \text{m}^2]$ $(\text{WK}^2 [\text{oz} \cdot \text{in}^2])$	Mass [kg] (lb)
HC-RP103	1.0	1.50 (8.20)	3.9 (8.60)

[Unit: mm]

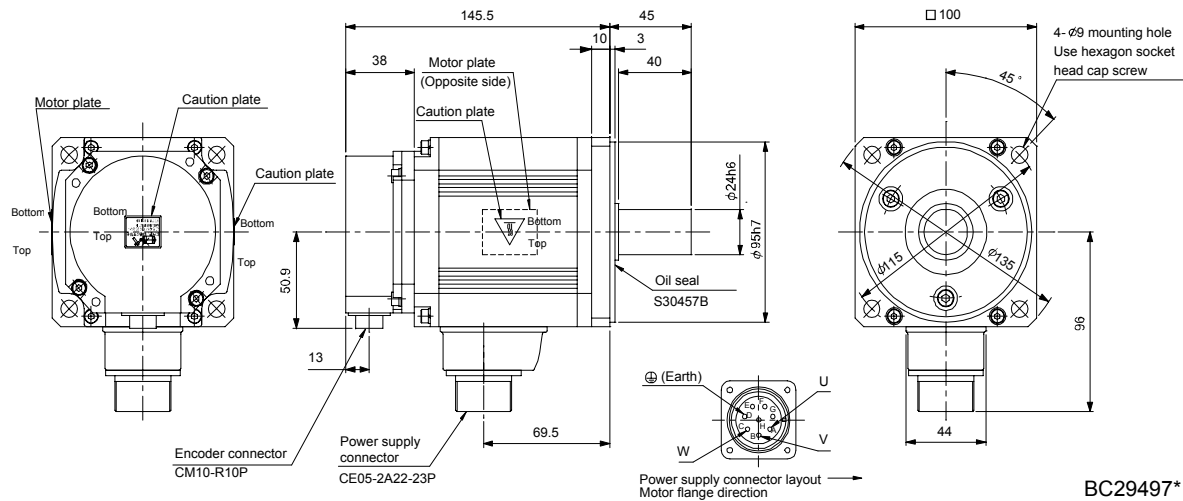

BC29497\*

Model	Output [kW]	Inertia moment $J [\times 10^{-4} \text{kg} \cdot \text{m}^2]$ $(\text{WK}^2 [\text{oz} \cdot \text{in}^2])$	Mass [kg] (lb)
HC-RP153	1.5	1.90 (10.4)	5.0 (11.0)

[Unit: mm]

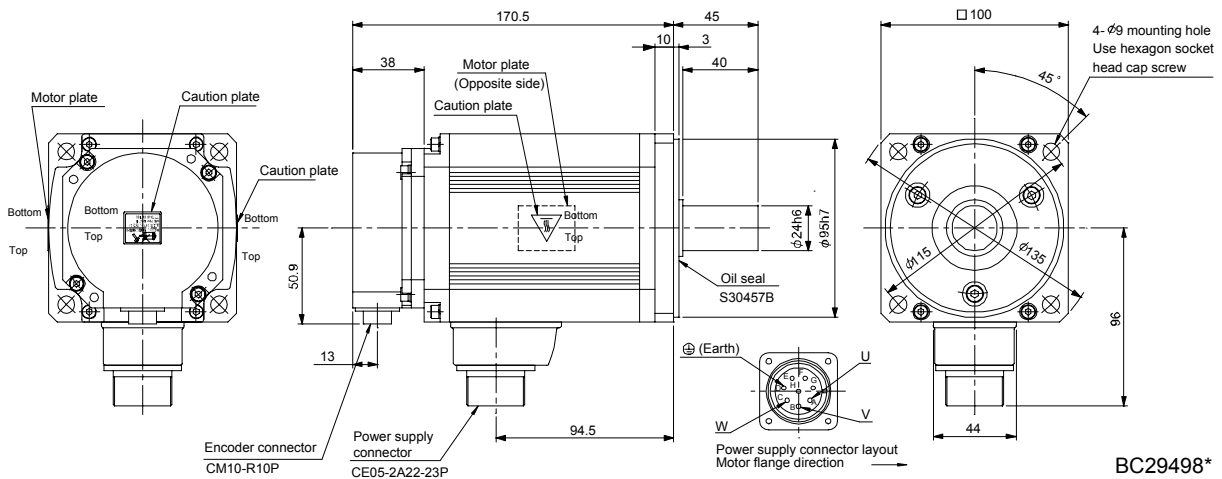

BC29498\*

# 9. HC-RP SERIES

Model	Output [kW]	Inertia moment J [ $\times 10^{-4}$ kg · m <sup>2</sup> ] (WK <sup>2</sup> [oz · in <sup>2</sup> ])	Mass [kg] (lb)
HC-RP203	2.0	2.30 (12.6)	6.2 (13.7)

[Unit: mm]

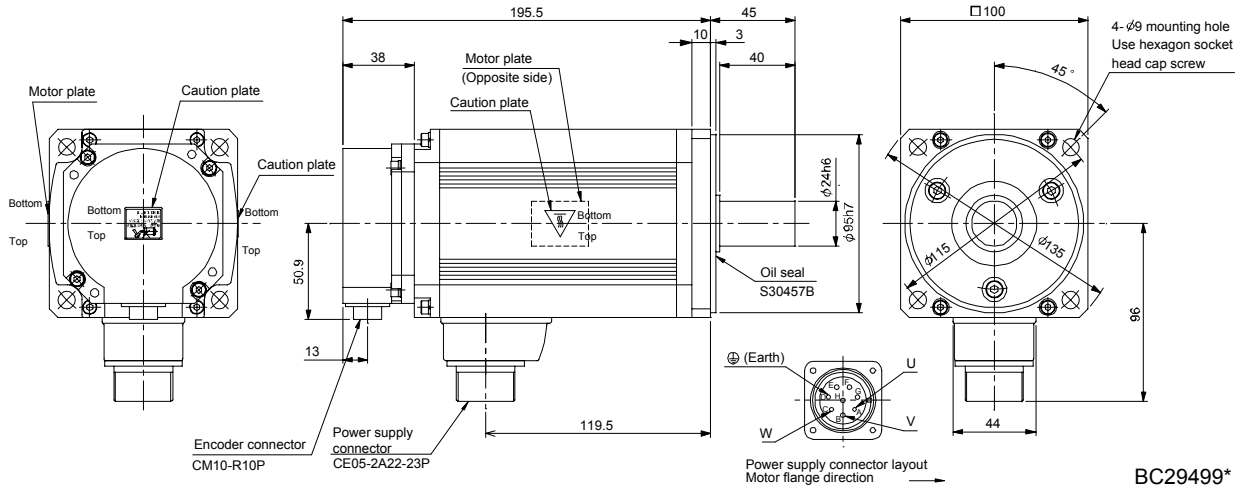

BC29499\*

Model	Output [kW]	Inertia moment J [ $\times 10^{-4}$ kg · m <sup>2</sup> ] (WK <sup>2</sup> [oz · in <sup>2</sup> ])	Mass [kg] (lb)
HC-RP353	3.5	8.30 (45.4)	12 (26.5)

[Unit: mm]

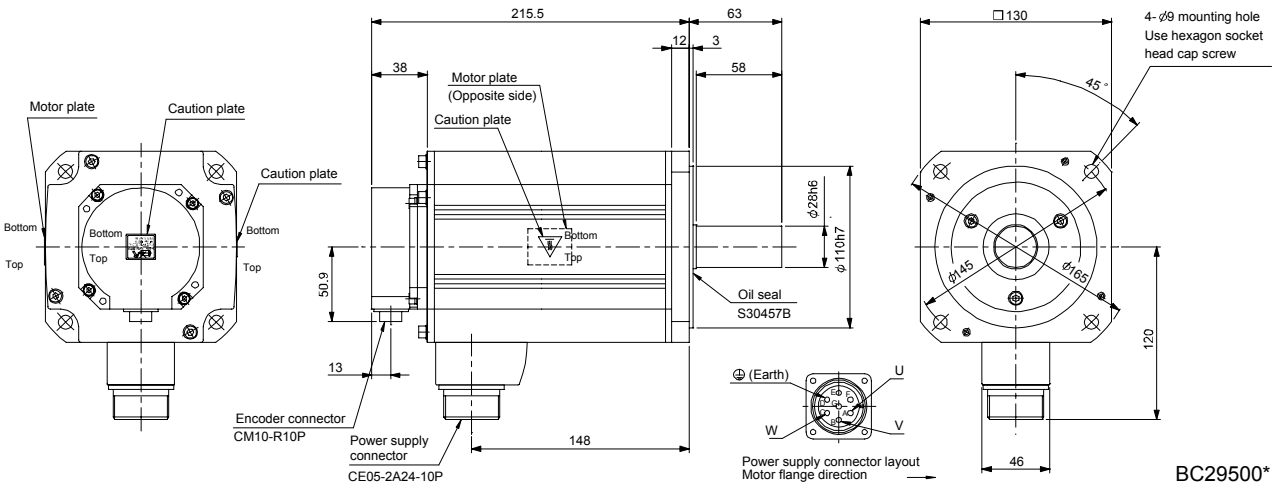

BC29500\*



## 9. HC-RP SERIES

Model	Output [kW]	Inertia moment J [ $\times 10^{-4}$ kg · m <sup>2</sup> ] (WK <sup>2</sup> [oz · in <sup>2</sup> ])	Mass [kg] (lb)
HC-RP503	5.0	12.0 (65.6)	17 (37.5)

[Unit: mm]

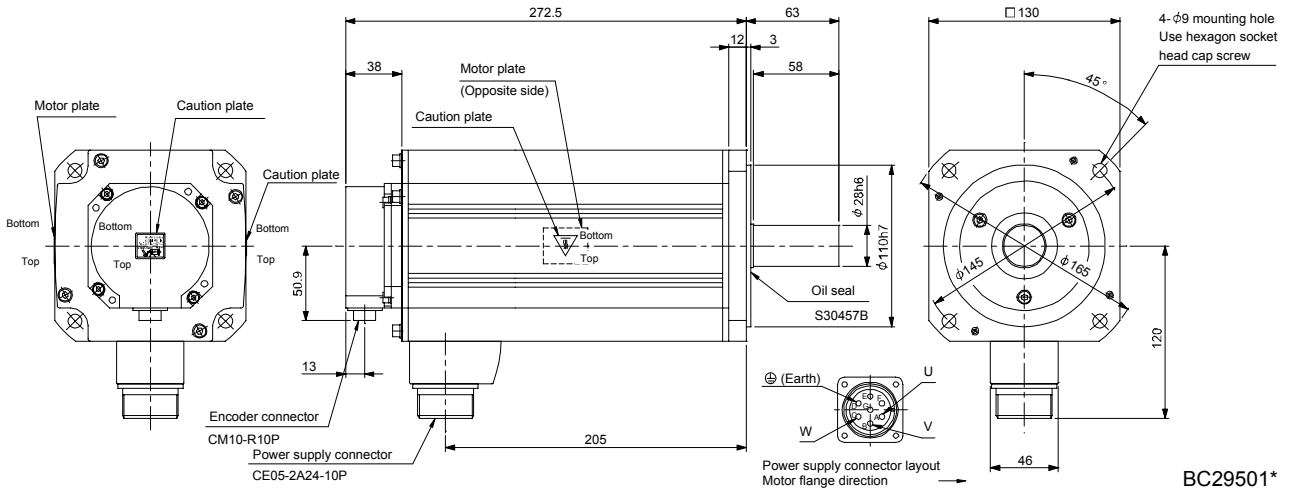

### 9.7.2 With an electromagnetic brake

Model	Output [kW]	Brake static friction torque [N · m] (oz · in)	Inertia moment J [ $\times 10^{-4}$ kg · m <sup>2</sup> ] (WK <sup>2</sup> [oz · in <sup>2</sup> ])	Mass [kg] (lb)
HC-RP103B	1.0	7 (991)	1.85 (10.1)	6.0 (13.2)

[Unit: mm]

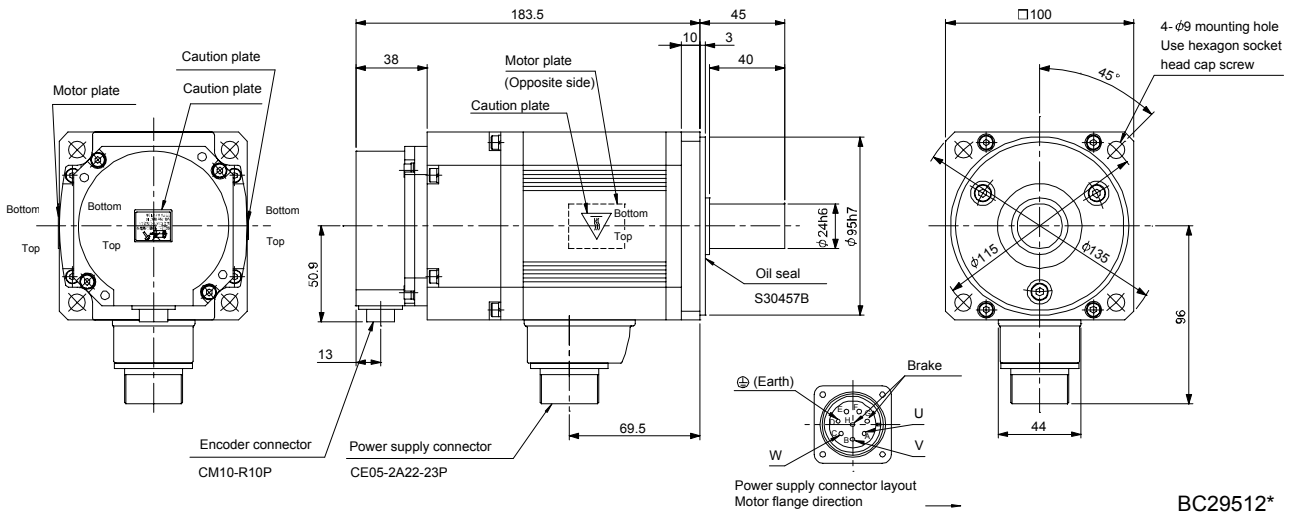

# 9. HC-RP SERIES

Model	Output [kW]	Brake static friction torque [N · m] (oz · in)	Inertia moment $J [ \times 10^{-4} \text{kg} \cdot \text{m}^2 ]$ (WK <sup>2</sup> [oz · in <sup>2</sup> ])	Mass [kg] (lb)
HC-RP153B	1.5	7 (991)	2.25 (12.3)	7.0 (15.4)

[Unit: mm]

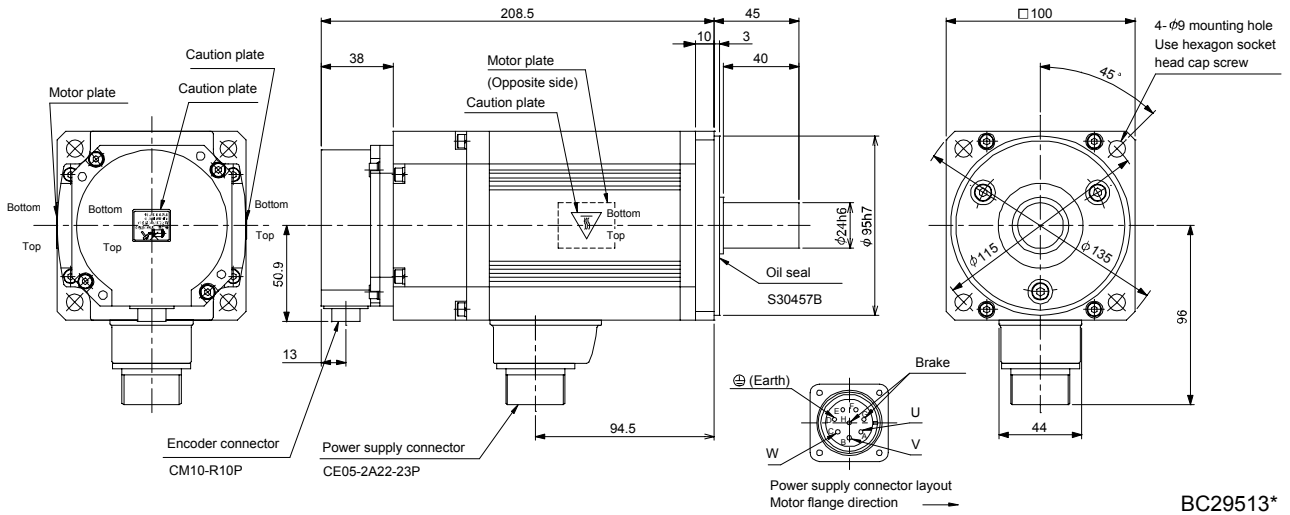

BC29513\*

Model	Output [kW]	Brake static friction torque [N · m] (oz · in)	Inertia moment $J [ \times 10^{-4} \text{kg} \cdot \text{m}^2 ]$ (WK <sup>2</sup> [oz · in <sup>2</sup> ])	Mass [kg] (lb)
HC-RP203B	2.0	7 (991)	2.65 (14.5)	8.3 (18.3)

[Unit: mm]

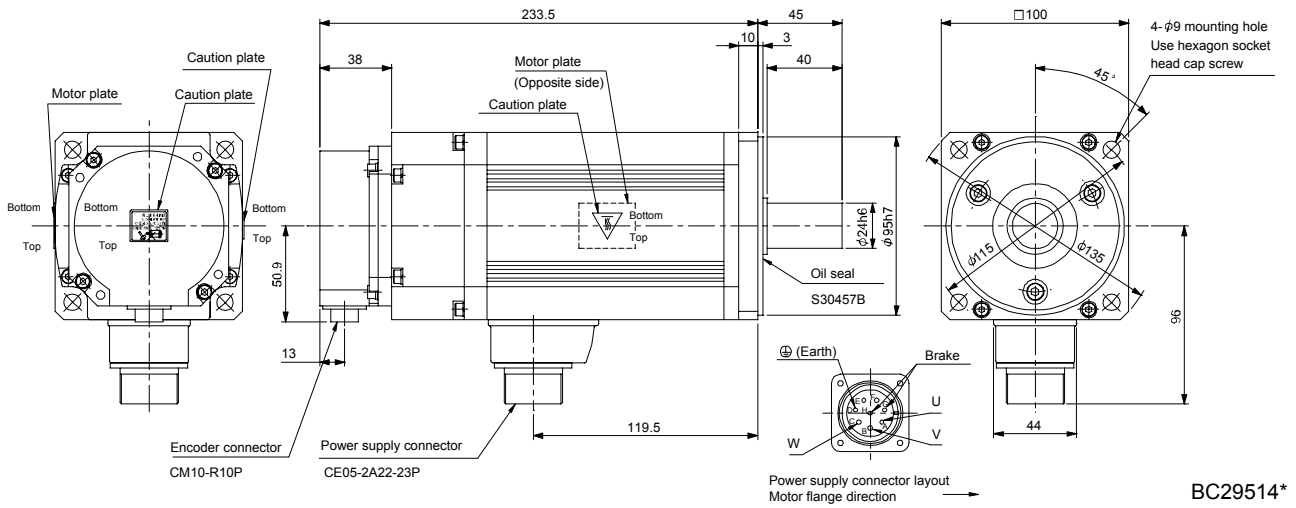

BC29514\*

# 9. HC-RP SERIES

Model	Output [kW]	Brake static friction torque [N · m] ([oz · in])	Inertia moment $J [ \times 10^{-4} \text{kg} \cdot \text{m}^2 ]$ ( $\text{WK}^2 [\text{oz} \cdot \text{in}^2]$ )	Mass [kg] ([lb])
HC-RP353B	3.5	17 (2410)	11.8 (64.5)	15 (33.1)

[Unit: mm]

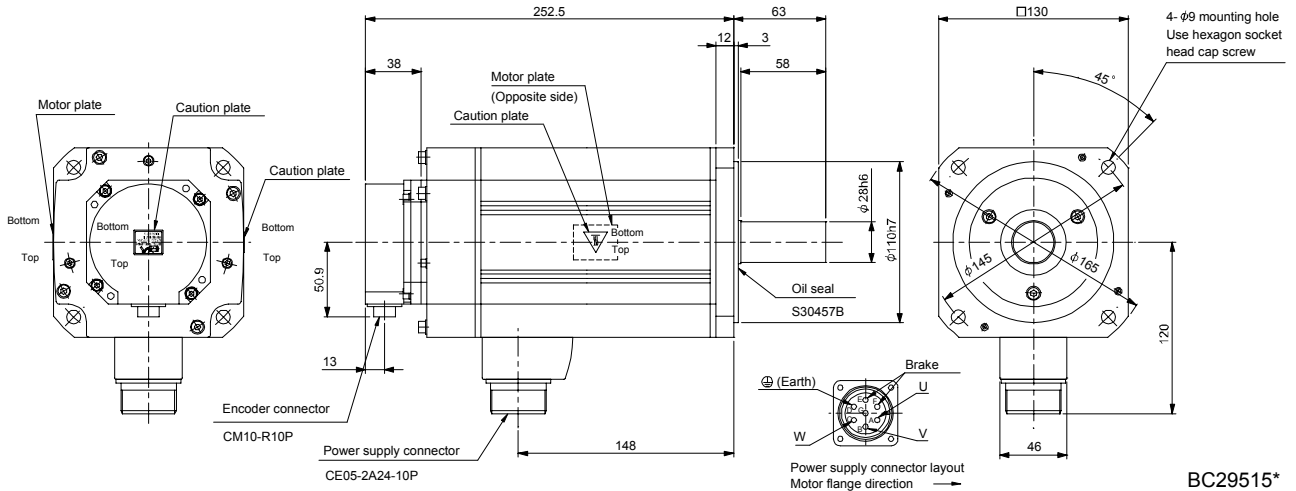

BC29515\*

Model	Output [kW]	Brake static friction torque [N · m] ([oz · in])	Inertia moment $J [ \times 10^{-4} \text{kg} \cdot \text{m}^2 ]$ ( $\text{WK}^2 [\text{oz} \cdot \text{in}^2]$ )	Mass [kg] ([lb])
HC-RP503B	5.0	17 (2410)	15.5 (84.7)	21 (46.3)

[Unit: mm]

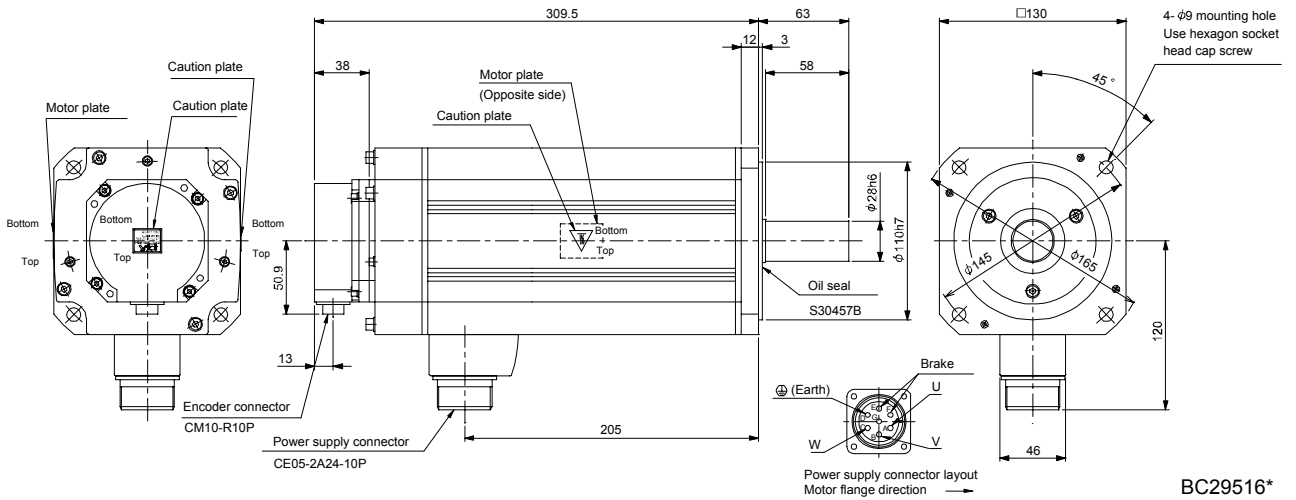

BC29516\*

## 9. HC-RP SERIES

### 9.7.3 Flange-mounting flange output type for precision application compliant (without an electromagnetic brake)

Model	Output [kW]	Reduction gear model	Reduction ratio (Actual reduction ratio)	Inertia moment $J$ [ $\times 10^{-4} \text{kg} \cdot \text{m}^2$ ] ( $\text{WK}^2$ [oz · in <sup>2</sup> ])	Mass [kg] ([lb])
HC-RP103G5	1.0	HPG-20A-05-FOLBWS-S	1/5	2.33 (12.7)	6.4 (14.1)
		HPG-20A-11-FOLBXS-S	1/11	2.25 (12.3)	6.6 (14.6)

[Unit: mm]

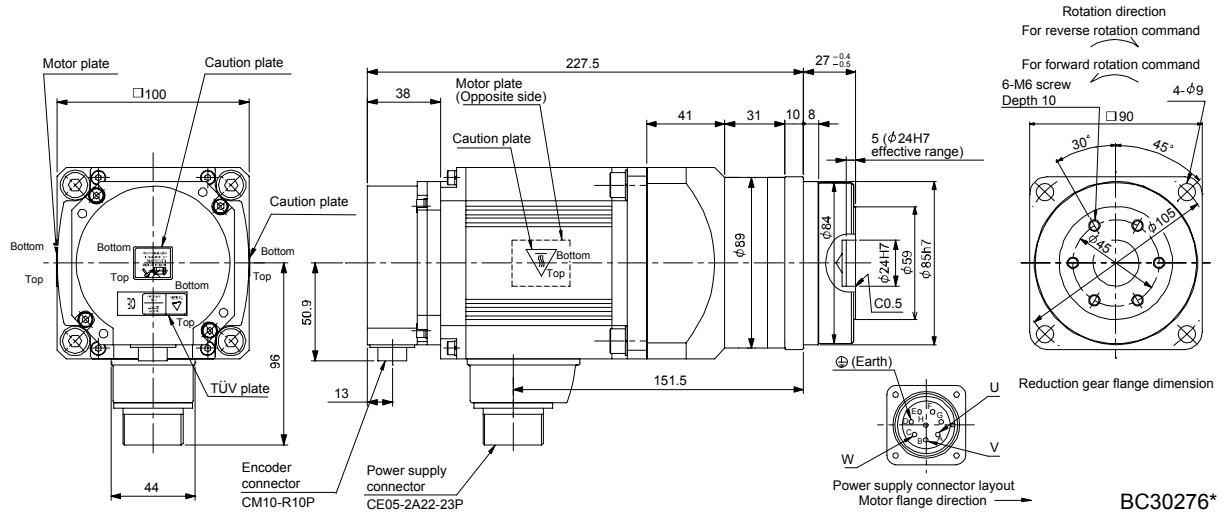

Model	Output [kW]	Reduction gear model	Reduction ratio (Actual reduction ratio)	Inertia moment $J$ [ $\times 10^{-4} \text{kg} \cdot \text{m}^2$ ] ( $\text{WK}^2$ [oz · in <sup>2</sup> ])	Mass [kg] ([lb])
HC-RP103G5	1.0	HPG-32A-21-FONFSYS-S	1/21	4.40 (24.1)	10.4 (22.9)
		HPG-32A-33-FONFSZS-S	1/33	4.20 (23.0)	

[Unit: mm]

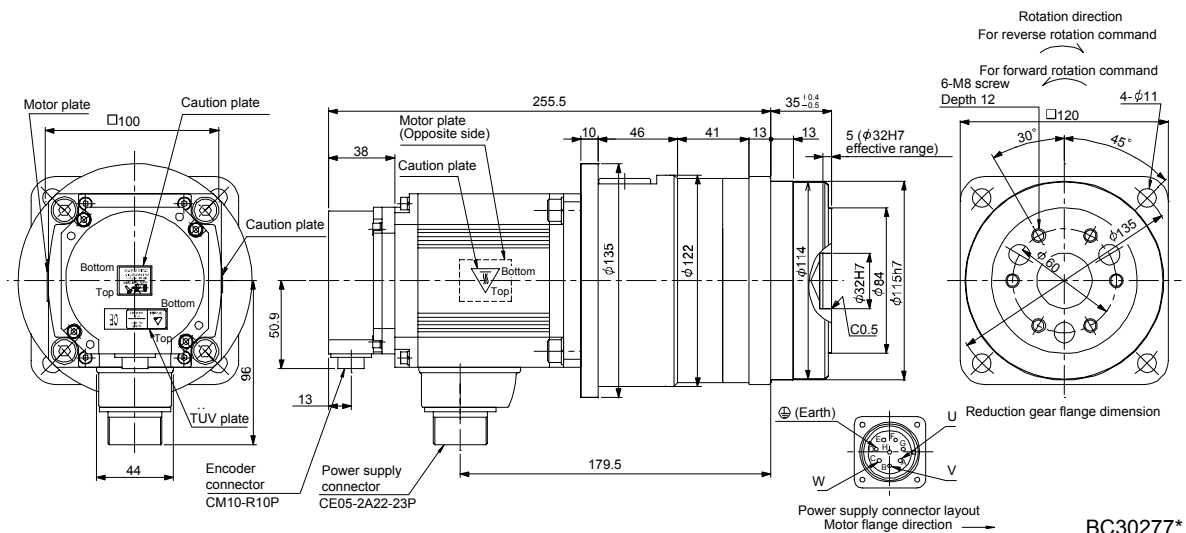

# 9. HC-RP SERIES

Model	Output [kW]	Reduction gear model	Reduction ratio (Actual reduction ratio)	Inertia moment $J$ [ $\times 10^{-4} \text{kg} \cdot \text{m}^2$ ] ( $\text{WK}^2$ [oz · in <sup>2</sup> ])	Mass [kg] ([lb])
HC-RP103G5	1.0	HPG-50A-45-FOADBC-S	1/45	6.10 (33.4)	19.9 (43.9)

[Unit: mm]

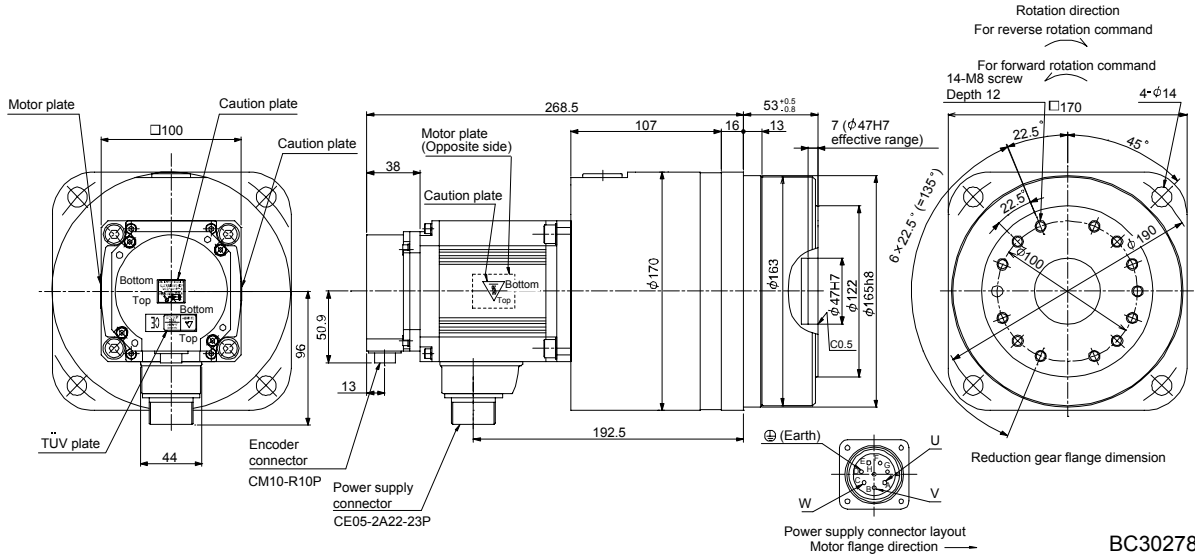

BC30278\*

Model	Output [kW]	Reduction gear model	Reduction ratio (Actual reduction ratio)	Inertia moment $J$ [ $\times 10^{-4} \text{kg} \cdot \text{m}^2$ ] ( $\text{WK}^2$ [oz · in <sup>2</sup> ])	Mass [kg] ([lb])
HC-RP153G5	1.5	HPG-20A-05-FOLBWS-S	1/5	2.73 (14.9)	7.5 (16.5)

[Unit: mm]

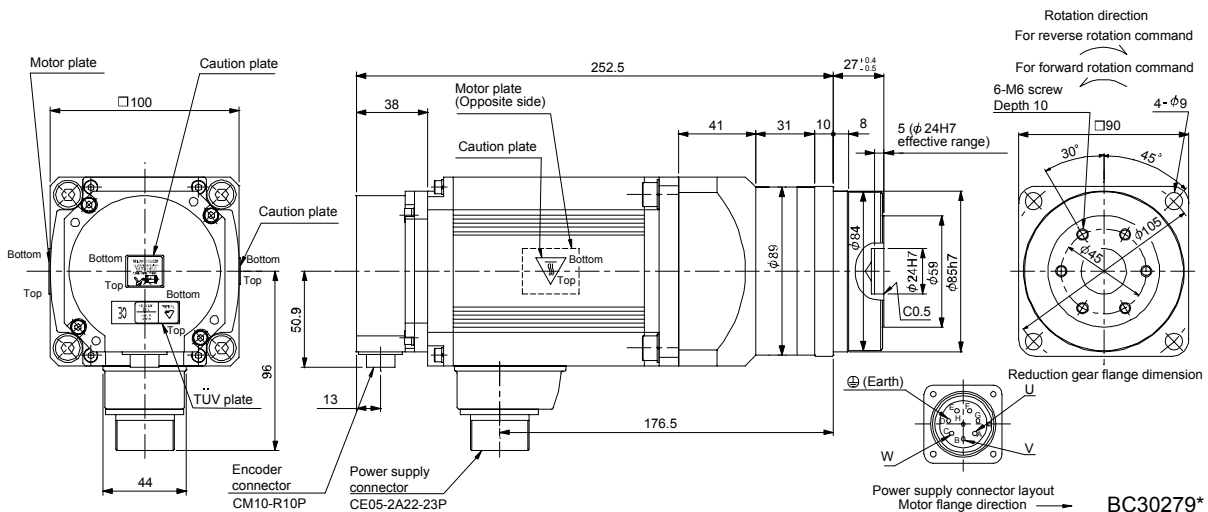

BC30279\*

# 9. HC-RP SERIES

Model	Output [kW]	Reduction gear model	Reduction ratio (Actual reduction ratio)	Inertia moment $J [\times 10^{-4} \text{kg} \cdot \text{m}^2] (\text{WK}^2 [\text{oz} \cdot \text{in}^2])$	Mass [kg] ([lb])
HC-RP153G5	1.5	HPG-32A-11-FONFSPS-S	1/11	5.20 (28.4)	11.5 (25.4)
		HPG-32A-21-FONFSYS-S	1/21	4.80 (26.2)	

[Unit: mm]

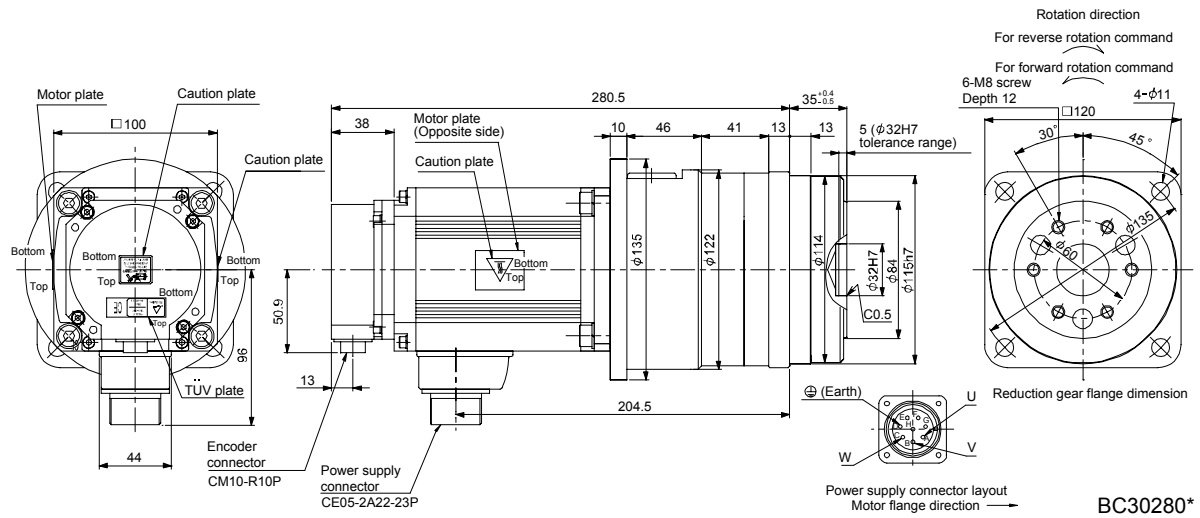

Model	Output [kW]	Reduction gear model	Reduction ratio (Actual reduction ratio)	Inertia moment $J [\times 10^{-4} \text{kg} \cdot \text{m}^2] (\text{WK}^2 [\text{oz} \cdot \text{in}^2])$	Mass [kg] ([lb])
HC-RP153G5	1.5	HPG-50A-33-FOADBC-S	1/33	6.60 (36.1)	21.0 (46.3)
		HPG-50A-45-FOADBC-S	1/45	6.50 (35.5)	

[Unit: mm]

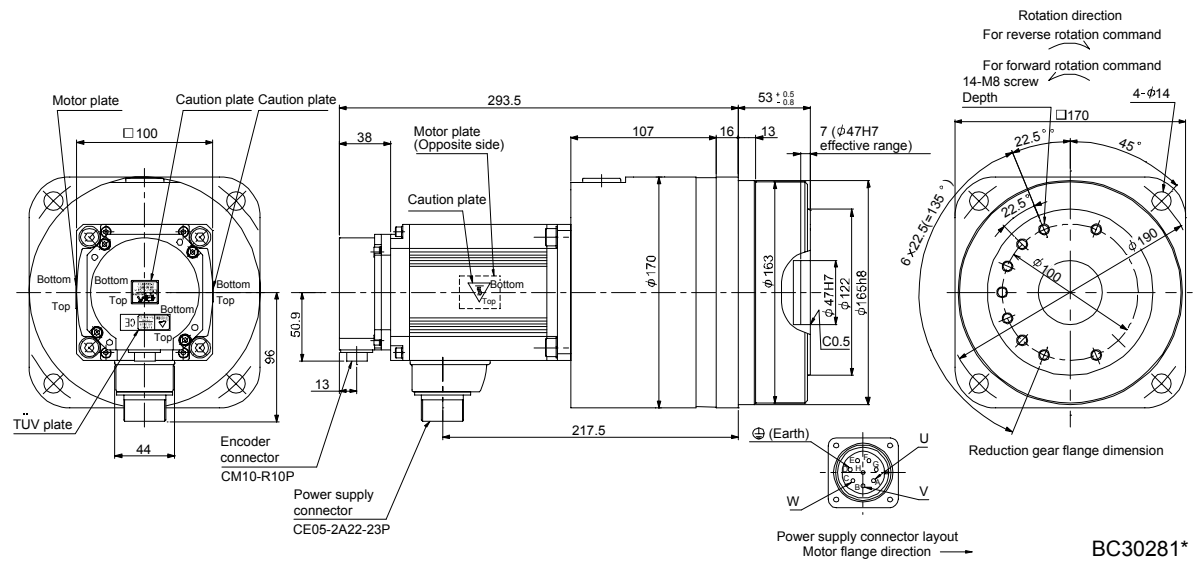

# 9. HC-RP SERIES

Model	Output [kW]	Reduction gear model	Reduction ratio (Actual reduction ratio)	Inertia moment $J [\times 10^{-4} \text{kg} \cdot \text{m}^2] (\text{WK}^2 [\text{oz} \cdot \text{in}^2])$	Mass [kg] (lb)
HC-RP203G5	2.0	HPG-20A-05-FOLBWS-S	1/5	3.13 (17.1)	8.7 (19.2)

[Unit: mm]

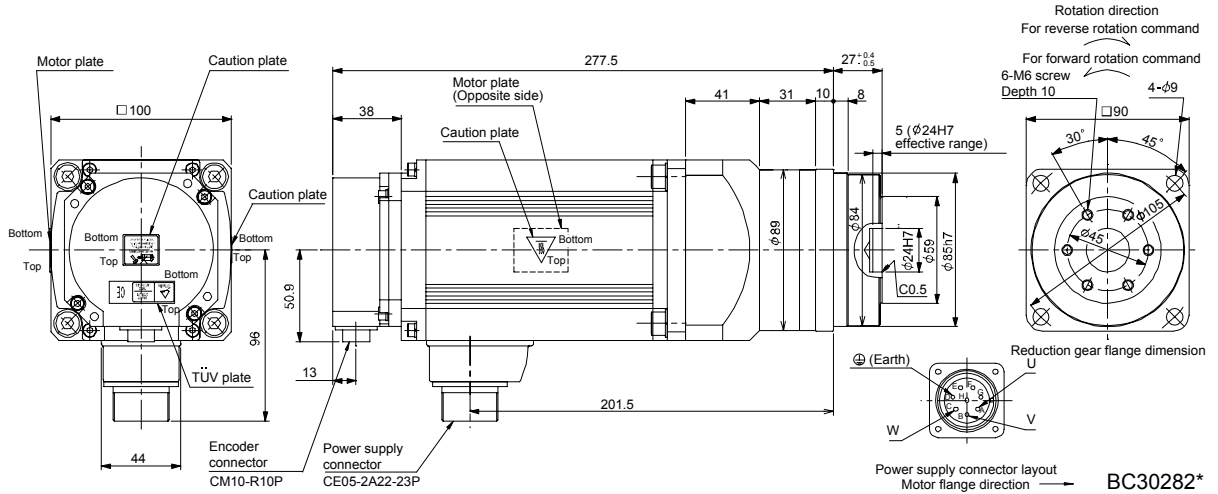

Model	Output [kW]	Reduction gear model	Reduction ratio (Actual reduction ratio)	Inertia moment $J [\times 10^{-4} \text{kg} \cdot \text{m}^2] (\text{WK}^2 [\text{oz} \cdot \text{in}^2])$	Mass [kg] (lb)
HC-RP203G5	2.0	HPG-32A-11-FONFSPS-S	1/11	5.60 (30.6)	12.7 (28.0)

[Unit: mm]

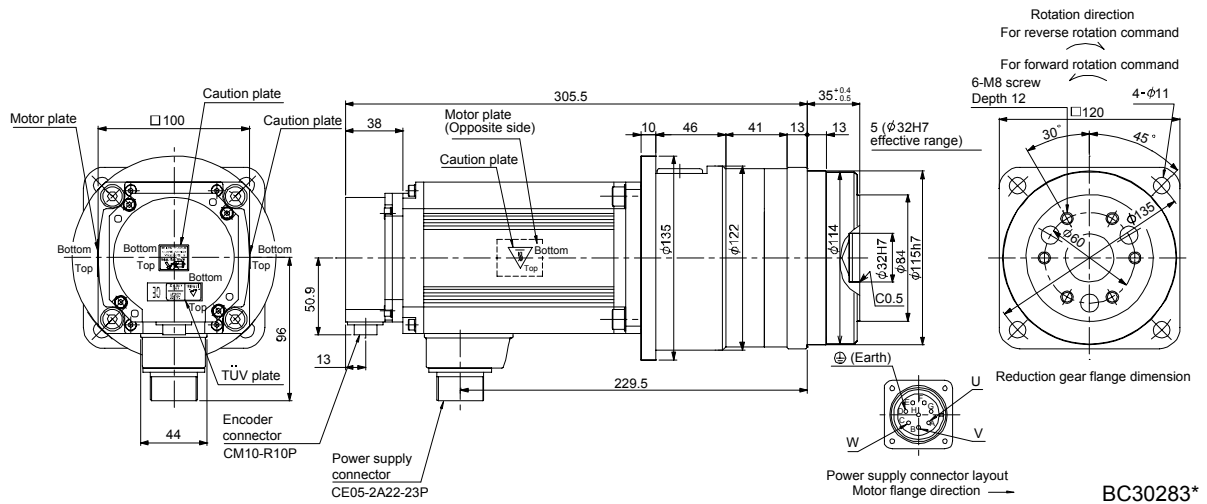

# 9. HC-RP SERIES

Model	Output [kW]	Reduction gear model	Reduction ratio (Actual reduction ratio)	Inertia moment $J [\times 10^{-4} \text{kg} \cdot \text{m}^2] (\text{WK}^2 [\text{oz} \cdot \text{in}^2])$	Mass [kg] ([lb])
HC-RP203G5	2.0	HPG-50A-21-FOADBC-S	1/21	8.00 (43.7)	22.2 (48.9)
		HPG-50A-33-FOADBC-S	1/33	7.00 (38.3)	
		HPG-50A-45-FOADBC-S	1/45	6.90 (37.7)	

[Unit: mm]

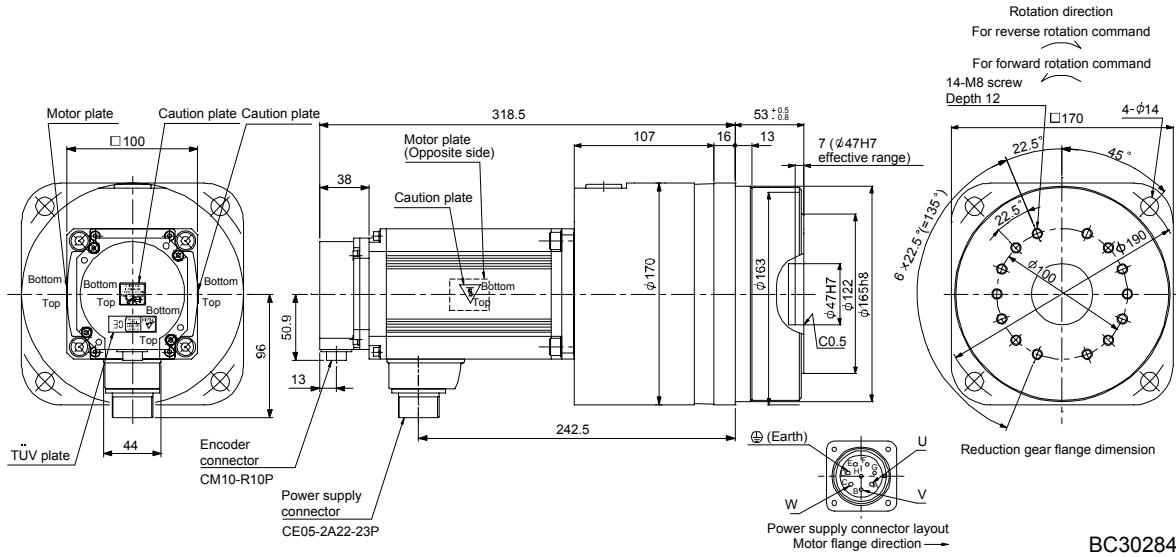

BC30284\*

Model	Output [kW]	Reduction gear model	Reduction ratio (Actual reduction ratio)	Inertia moment $J [\times 10^{-4} \text{kg} \cdot \text{m}^2] (\text{WK}^2 [\text{oz} \cdot \text{in}^2])$	Mass [kg] ([lb])
HC-RP353G5	3.5	HPG-32A-05-FOPAQS-S	1/5	13.2 (72.2)	18.5 (40.8)
		HPG-32A-11-FOPAR-S	1/11	13.0 (71.1)	19.0 (41.9)

[Unit: mm]

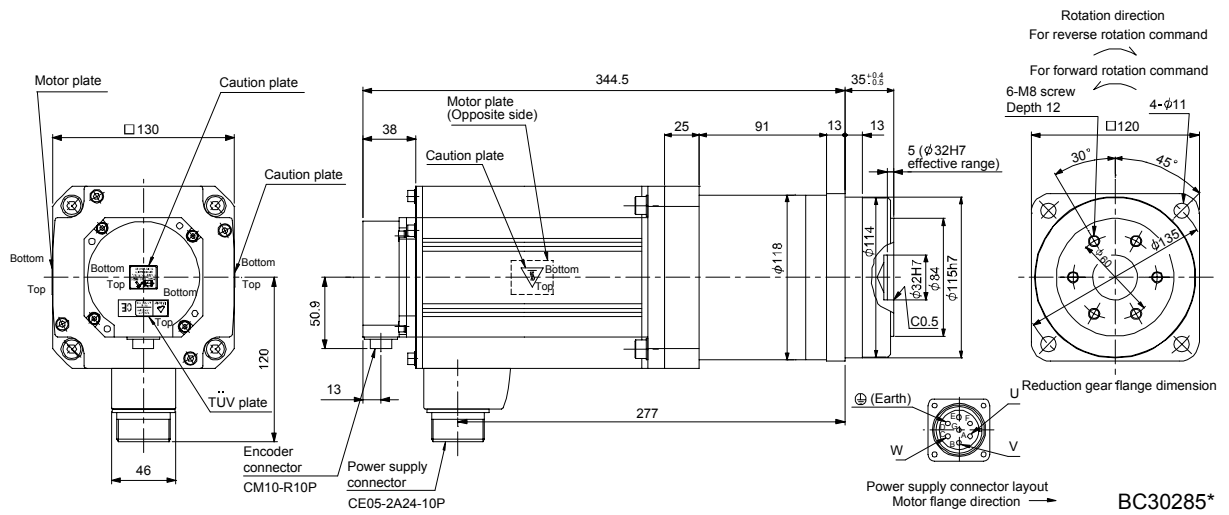

BC30285\*



## 9. HC-RP SERIES

Model	Output [kW]	Reduction gear model	Reduction ratio (Actual reduction ratio)	Inertia moment J [ $\times 10^{-4} \text{kg} \cdot \text{m}^2$ ] ( $\text{WK}^2$ [oz · in <sup>2</sup> ])	Mass [kg] ([lb])
HC-RP353G5	3.5	HPG-50A-21-FOBADD-S	1/21	15.0 (82.0)	28.1 (62.0)
		HPG-50A-33-FOBADD-S	1/33	14.1 (77.1)	

[Unit: mm]

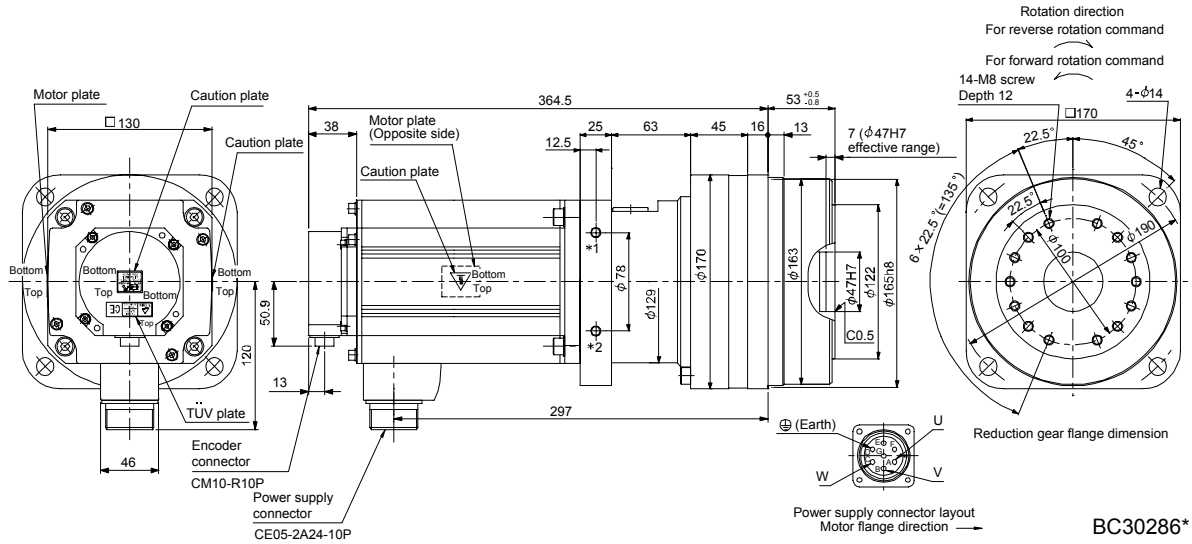

Note. \*1 and \*2 are the screw holes (M8) for the hangers.

Model	Output [kW]	Reduction gear model	Reduction ratio (Actual reduction ratio)	Inertia moment J [ $\times 10^{-4} \text{kg} \cdot \text{m}^2$ ] ( $\text{WK}^2$ [oz · in <sup>2</sup> ])	Mass [kg] ([lb])
HC-RP503G5	5.0	HPG-32A-05-FOPAQS-S	1/5	16.9 (92.4)	23.5 (51.8)

[Unit: mm]

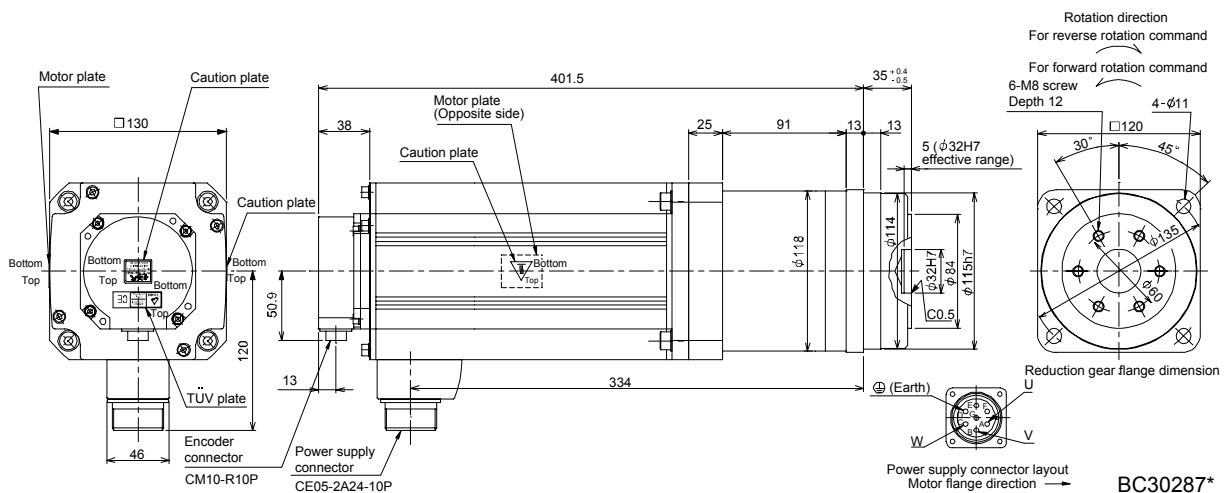

## 9. HC-RP SERIES

Model	Output [kW]	Reduction gear model	Reduction ratio (Actual reduction ratio)	Inertia moment $J [\times 10^{-4} \text{kg} \cdot \text{m}^2] (\text{WK}^2 [\text{oz} \cdot \text{in}^2])$	Mass [kg] ([lb])
HC-RP503G5	5.0	HPG-50A-11-FOBADD-S	1/11	20.5 (112)	33.1 (73.0)
		HPG-50A-21-FOBADD-S	1/21	18.7 (102)	

[Unit: mm]

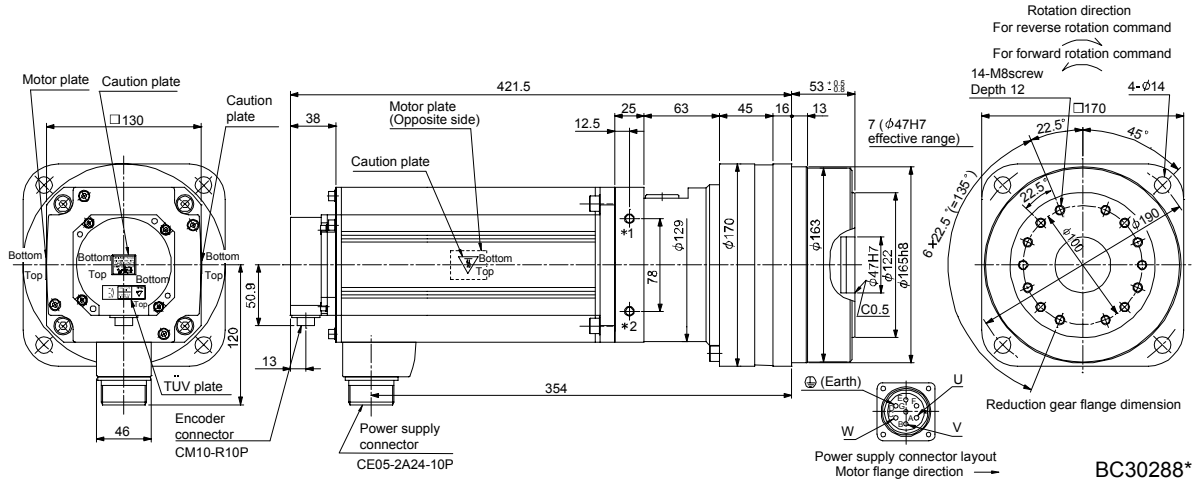

BC30288\*

Note. \*1 and \*2 are the screw holes (M8) for the hangers.

### 9.7.4 Flange-mounting flange output type for precision application compliant (with an electromagnetic brake)

Model	Output [kW]	Reduction gear model	Reduction ratio (Actual reduction ratio)	Brake static friction torque [N · m] ([oz · in])	Inertia moment $J [\times 10^{-4} \text{kg} \cdot \text{m}^2] (\text{WK}^2 [\text{oz} \cdot \text{in}^2])$	Mass [kg] ([lb])
HC-RP103BG5	1.0	HPG-20A-05-FOLBWS-S	1/5	7.0 (991)	2.68 (14.7)	8.5 (18.7)
		HPG-20A-11-FOLBXS-S	1/11		2.60 (14.2)	8.7 (19.2)

[Unit: mm]

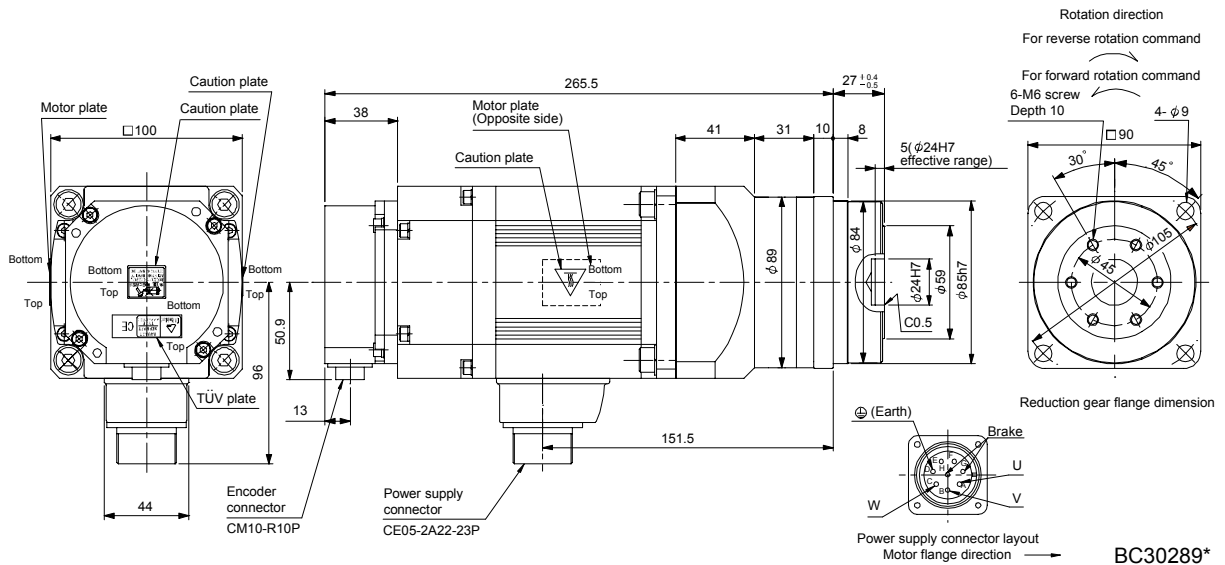

BC30289\*

# 9. HC-RP SERIES

Model	Output [kW]	Reduction gear model	Reduction ratio (Actual reduction ratio)	Brake static friction torque [N · m] ([oz · in])	Inertia moment J [ $\times 10^{-4} \text{kg} \cdot \text{m}^2$ ] ( $\text{WK}^2$ [oz · in <sup>2</sup> ])	Mass [kg] ([lb])
HC-RP103BG5	1.0	HPG-32A-21-FONFSYS-S	1/21	7.0 (991)	4.75 (26.0)	12.5 (27.6)
		HPG-32A-33-FONFSZS-S	1/33		4.55 (24.9)	

[Unit: mm]

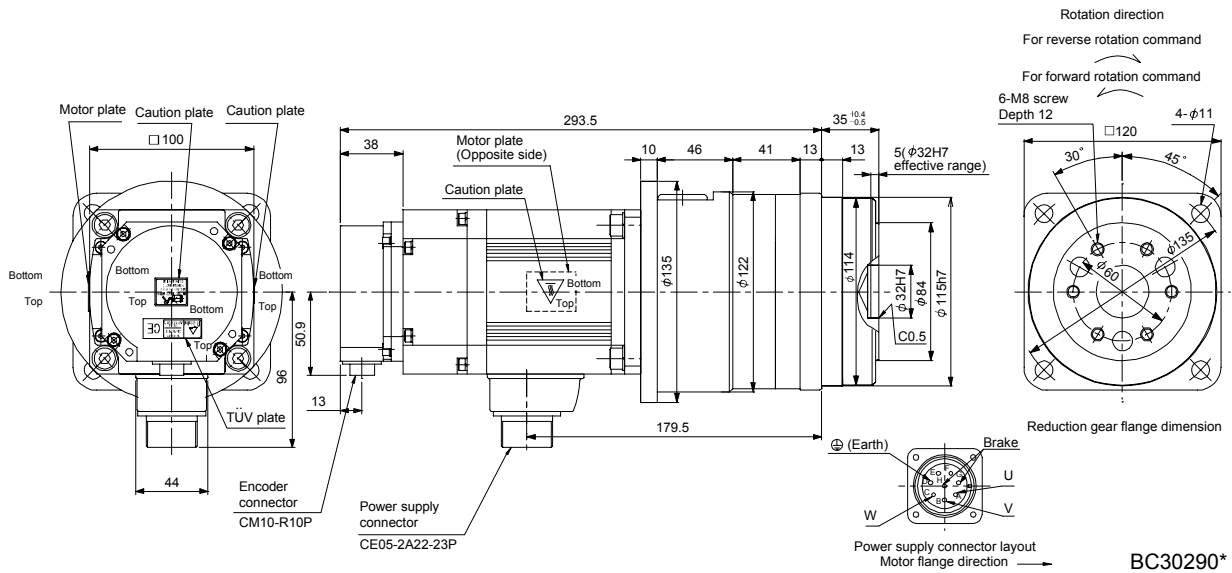

Model	Output [kW]	Reduction gear model	Reduction ratio (Actual reduction ratio)	Brake static friction torque [N · m] ([oz · in])	Inertia moment J [ $\times 10^{-4} \text{kg} \cdot \text{m}^2$ ] ( $\text{WK}^2$ [oz · in <sup>2</sup> ])	Mass [kg] ([lb])
HC-RP103BG5	1.0	HPG-50A-45-FOADBC-S	1/45	7.0 (991)	6.45 (35.3)	22.0 (48.5)

[Unit: mm]

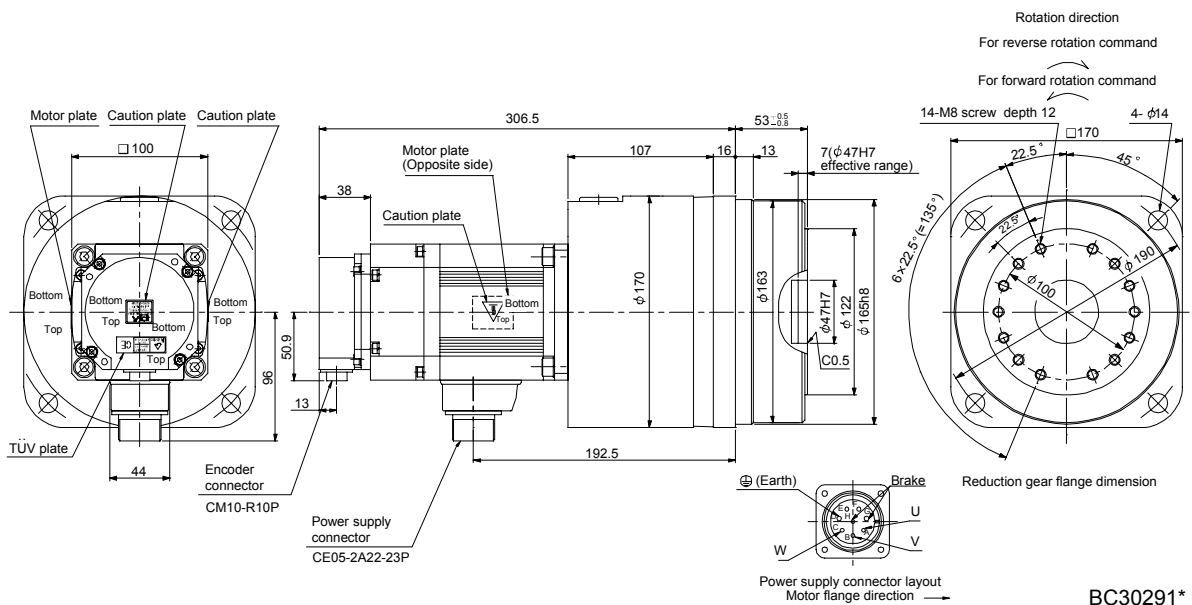





# 9. HC-RP SERIES

Model	Output [kW]	Reduction gear model	Reduction ratio (Actual reduction ratio)	Brake static friction torque [N · m] ([oz · in])	Inertia moment J [ $\times 10^{-4} \text{kg} \cdot \text{m}^2$ ] ( $\text{WK}^2$ [oz · in <sup>2</sup> ])	Mass [kg] ([lb])
HC-RP203BG5	2.0	HPG-32A-11-FONFSPS-S	1/11	7.0 (991)	5.95 (32.5)	14.8 (32.6)

[Unit: mm]

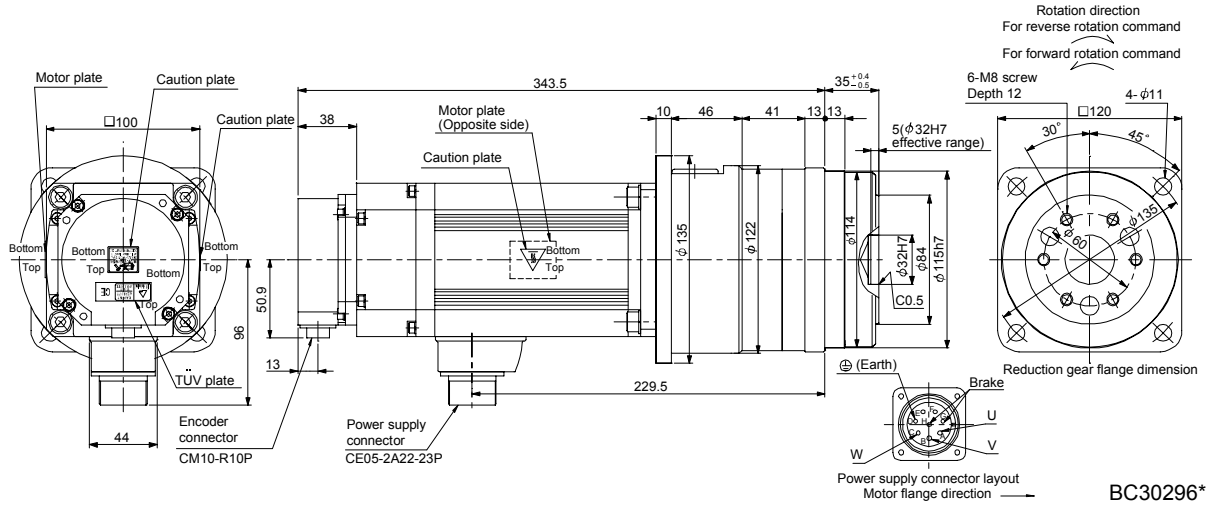

Model	Output [kW]	Reduction gear model	Reduction ratio (Actual reduction ratio)	Brake static friction torque [N · m] ([oz · in])	Inertia moment J [ $\times 10^{-4} \text{kg} \cdot \text{m}^2$ ] ( $\text{WK}^2$ [oz · in <sup>2</sup> ])	Mass [kg] ([lb])
HC-RP203BG5	2.0	HPG-50A-21-FOADBC-S	1/21	7.0 (991)	8.35 (45.7)	24.3 (53.6)
		HPG-50A-33-FOADBC-S	1/33		7.35 (40.2)	
		HPG-50A-45-FOADBC-S	1/45		7.25 (39.6)	

[Unit: mm]

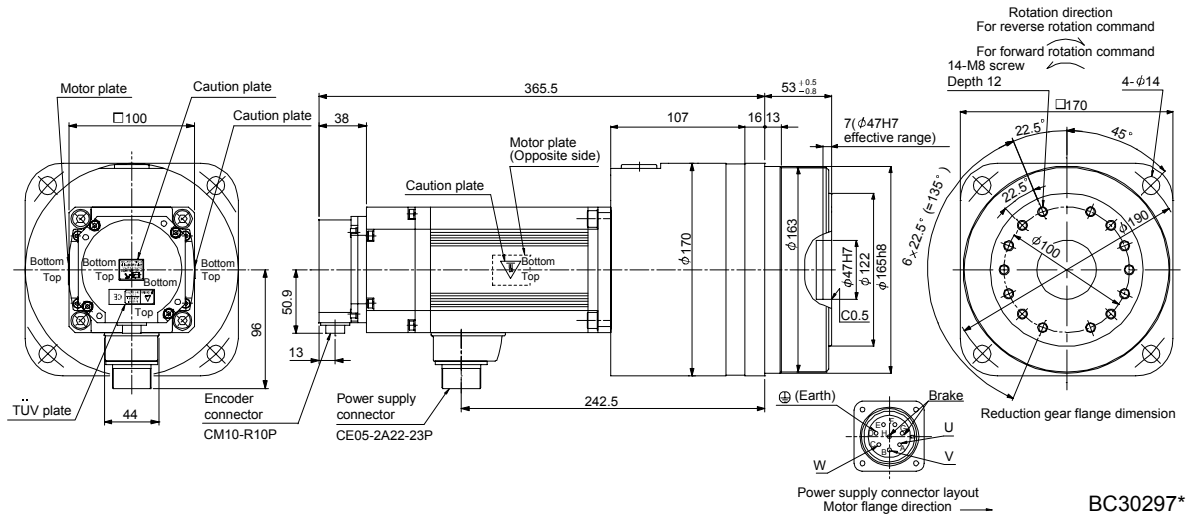

# 9. HC-RP SERIES

Model	Output [kW]	Reduction gear model	Reduction ratio (Actual reduction ratio)	Brake static friction torque [N · m] [(oz · in)]	Inertia moment J [ $\times 10^{-4} \text{kg} \cdot \text{m}^2$ ] ( $\text{WK}^2$ [oz · in <sup>2</sup> ])	Mass [kg] [(lb)]
HC-RP353BG5	3.5	HPG-32A-05-FOPAQS-S	1/5	16.7 (2370)	16.7 (91.3)	21.5 (47.4)
		HPG-32A-11-FOPAR-S	1/11		16.5 (90.2)	22.0 (48.5)

[Unit: mm]

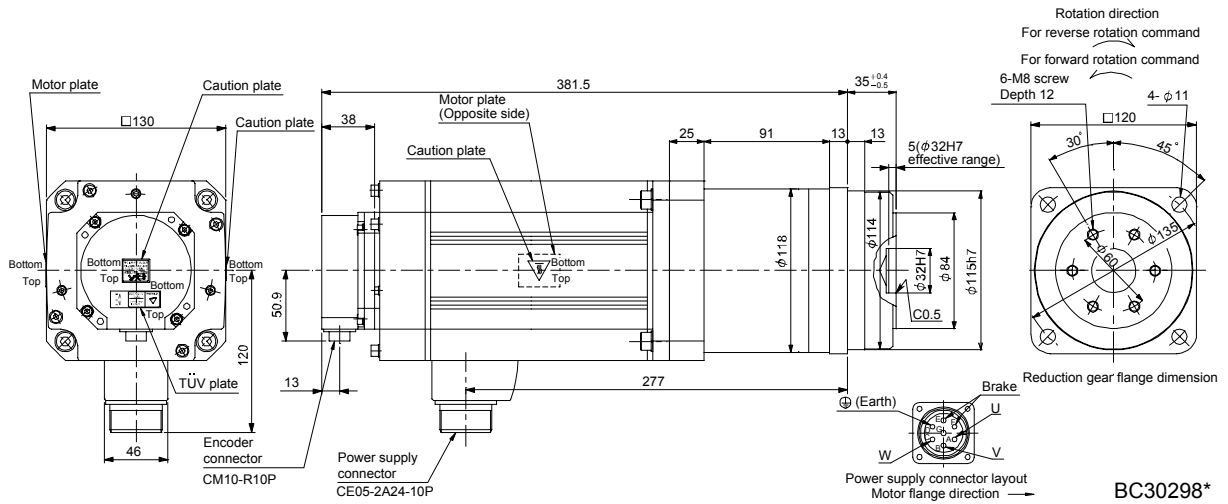

Model	Output [kW]	Reduction gear model	Reduction ratio (Actual reduction ratio)	Brake static friction torque [N · m] [(oz · in)]	Inertia moment J [ $\times 10^{-4} \text{kg} \cdot \text{m}^2$ ] ( $\text{WK}^2$ [oz · in <sup>2</sup> ])	Mass [kg] [(lb)]
HC-RP353BG5	3.5	HPG-50A-21-FOBADD-S	1/21	16.7 (2370)	18.5 (101)	31.1 (68.6)
		HPG-50A-33-FOBADD-S	1/33		17.6 (96.2)	

[Unit: mm]

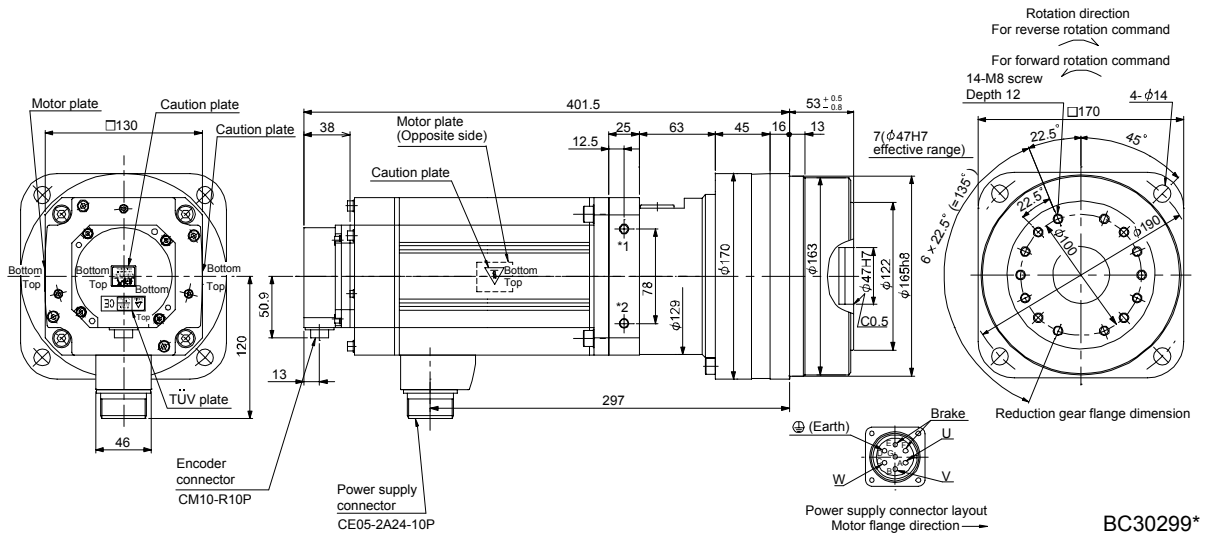

Note. \*1 and \*2 are the screw holes (M8) for the hangers.

# 9. HC-RP SERIES

Model	Output [kW]	Reduction gear model	Reduction ratio (Actual reduction ratio)	Brake static friction torque [N · m] (oz · in)	Inertia moment J [ $\times 10^{-4} \text{kg} \cdot \text{m}^2$ ] ( $\text{WK}^2$ [oz · in <sup>2</sup> ])	Mass [kg] (lb)
HC-RP503BG5	5.0	HPG-32A-05-FOPAQS-S	1/5	16.7 (2370)	20.4 (112)	27.5 (60.6)

[Unit: mm]

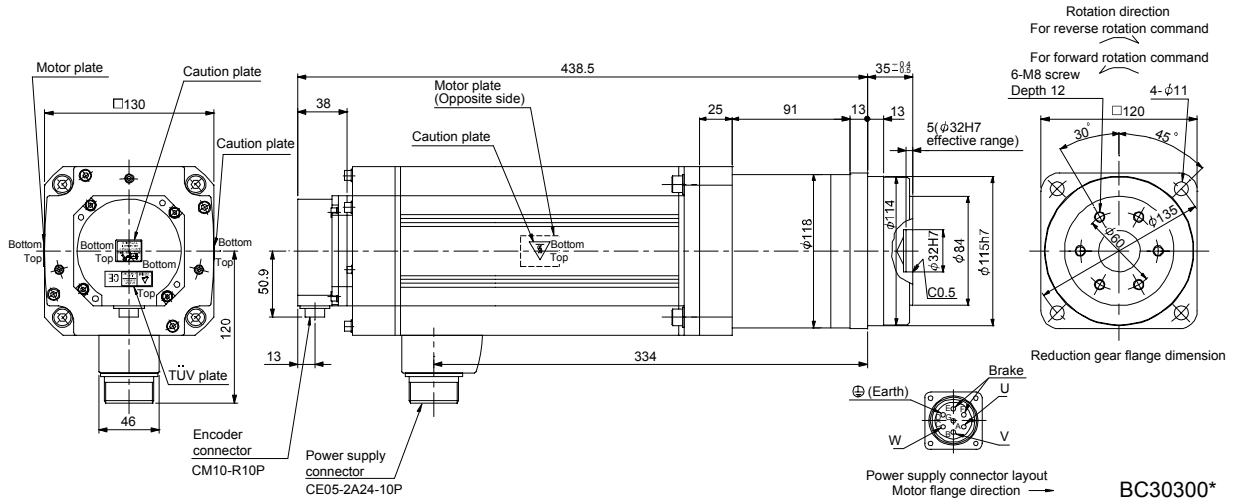

Model	Output [kW]	Reduction gear model	Reduction ratio (Actual reduction ratio)	Brake static friction torque [N · m] (oz · in)	Inertia moment J [ $\times 10^{-4} \text{kg} \cdot \text{m}^2$ ] ( $\text{WK}^2$ [oz · in <sup>2</sup> ])	Mass [kg] (lb)
HC-RP503BG5	5.0	HPG-50A-11-FOBADD-S	1/11	16.7 (2370)	24.0 (131)	37.1 (81.8)
		HPG-50A-21-FOBADD-S	1/21		22.2 (121)	

[Unit: mm]

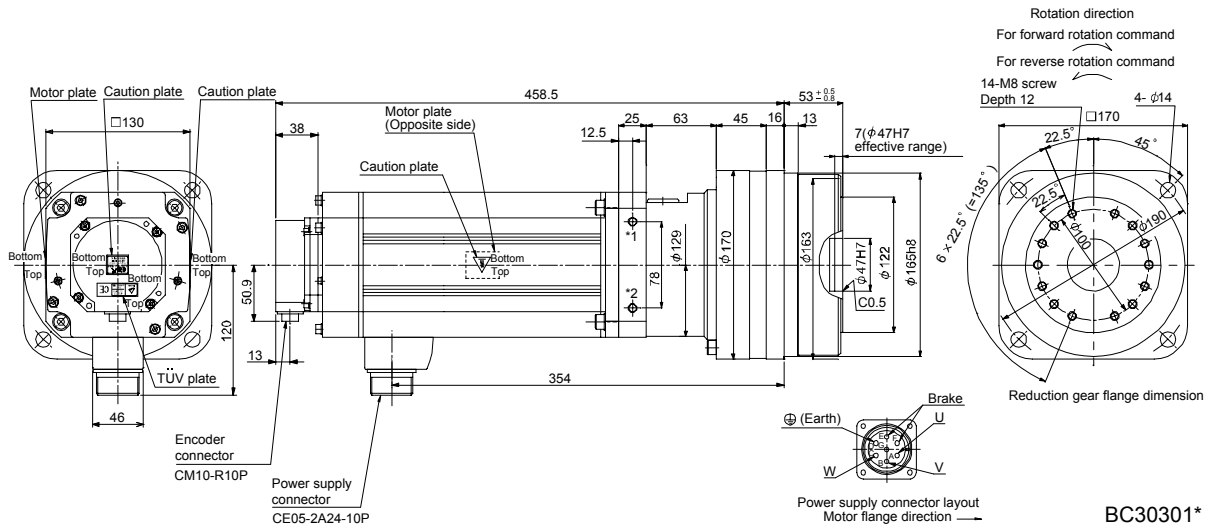

Note. \*1 and \*2 are the screw holes (M8) for the hangers.



## 9. HC-RP SERIES

### 9.7.5 Flange-mounting shaft output type for precision application compliant (without an electromagnetic brake)

Model	Output [kW]	Reduction gear model	Reduction ratio (Actual reduction ratio)	Inertia moment $J [\times 10^{-4} \text{kg} \cdot \text{m}^2] (\text{WK}^2 [\text{oz} \cdot \text{in}^2])$	Mass [kg] ([lb])
HC-RP103G7	1.0	HPG-20A-05-J2LBWS-S	1/5	2.37 (13.0)	6.8 (15.0)
		HPG-20A-11-J2LBXS-S	1/11	2.25 (12.3)	7.0 (15.4)

[Unit: mm]

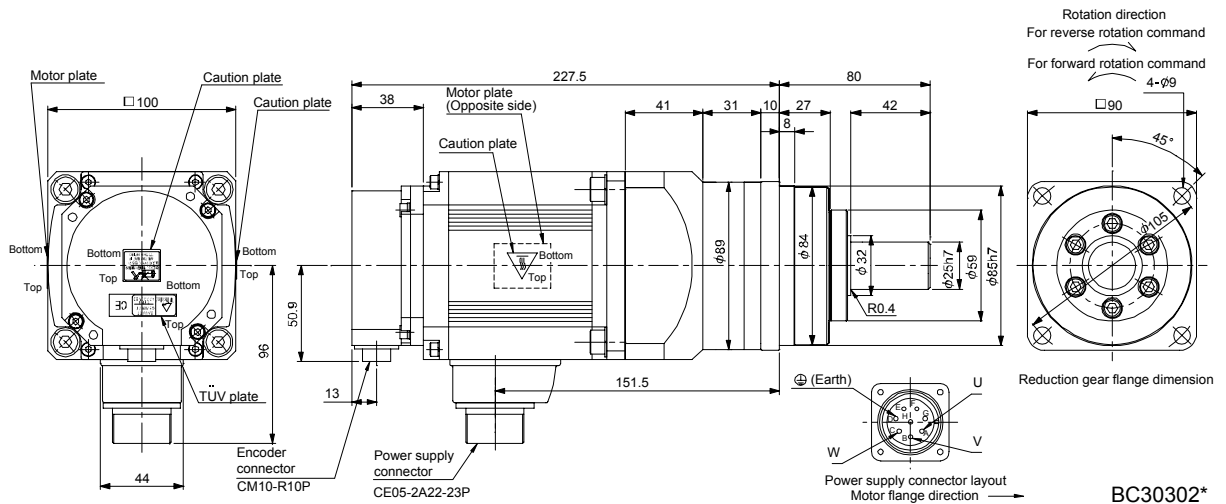

Model	Output [kW]	Reduction gear model	Reduction ratio (Actual reduction ratio)	Inertia moment $J [\times 10^{-4} \text{kg} \cdot \text{m}^2] (\text{WK}^2 [\text{oz} \cdot \text{in}^2])$	Mass [kg] ([lb])
HC-RP103G7	1.0	HPG-32A-21-J2NFSYS-S	1/21	4.40 (24.1)	11.8 (26.0)
		HPG-32A-33-J2NFSZS-S	1/33	4.20 (23.0)	

[Unit: mm]

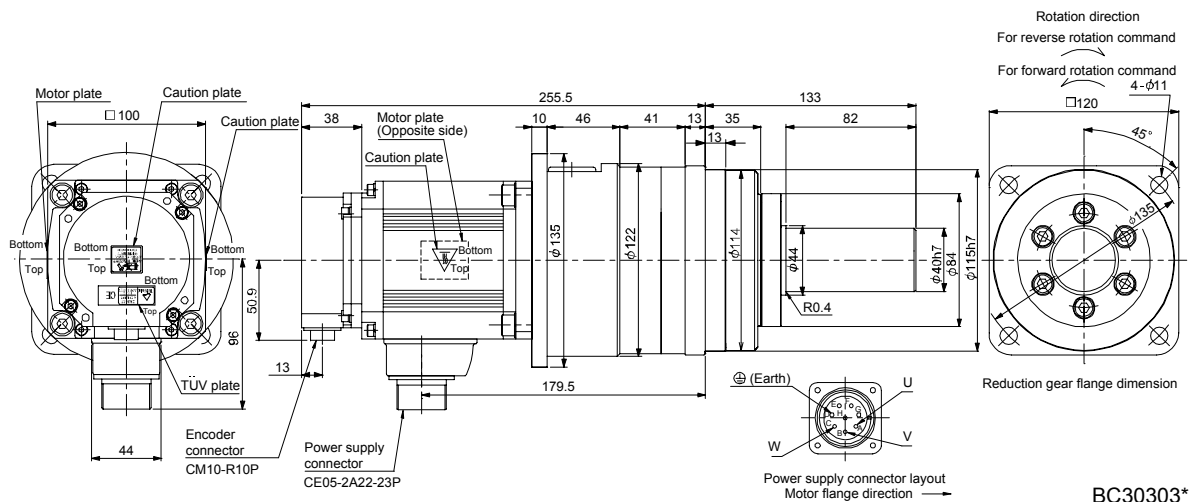

# 9. HC-RP SERIES

Model	Output [kW]	Reduction gear model	Reduction ratio (Actual reduction ratio)	Inertia moment $J [\times 10^{-4} \text{kg} \cdot \text{m}^2] (\text{WK}^2 [\text{oz} \cdot \text{in}^2])$	Mass [kg] ([lb])
HC-RP103G7	1.0	HPG-50A-45-J2ADBC-S	1/45	6.20 (33.9)	22.9 (50.5)

[Unit: mm]

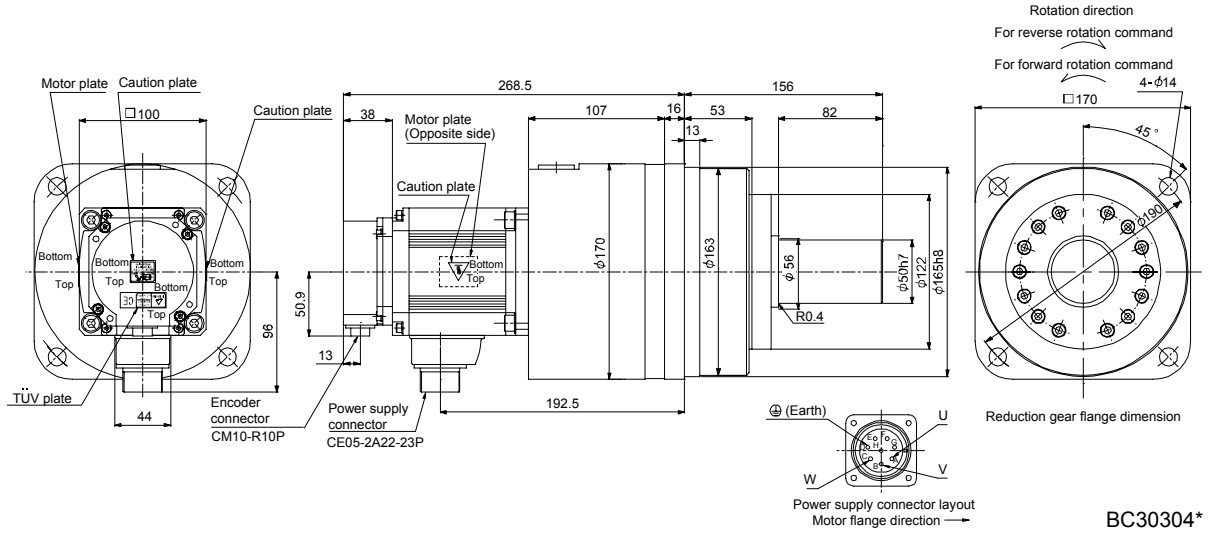

Model	Output [kW]	Reduction gear model	Reduction ratio (Actual reduction ratio)	Inertia moment $J [\times 10^{-4} \text{kg} \cdot \text{m}^2] (\text{WK}^2 [\text{oz} \cdot \text{in}^2])$	Mass [kg] ([lb])
HC-RP153G7	1.5	HPG-20A-05-J2LBWS-S	1/5	2.77 (15.1)	7.9 (17.4)

[Unit: mm]

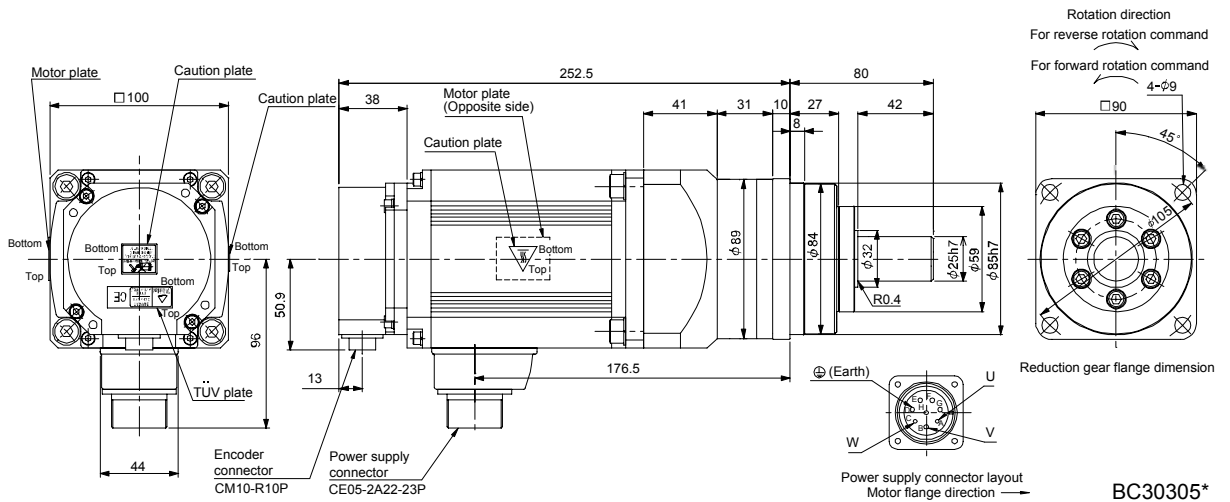

# 9. HC-RP SERIES

Model	Output [kW]	Reduction gear model	Reduction ratio (Actual reduction ratio)	Inertia moment J [ $\times 10^{-4} \text{kg} \cdot \text{m}^2$ ] (WK <sup>2</sup> [oz · in <sup>2</sup> ])	Mass [kg] ([lb])
HC-RP153G7	1.5	HPG-32A-11-J2NFSPS-S	1/11	5.30 (29.0)	12.9 (28.4)
		HPG-20A-11-J2NFSYS-S	1/21	4.80 (26.2)	

[Unit: mm]

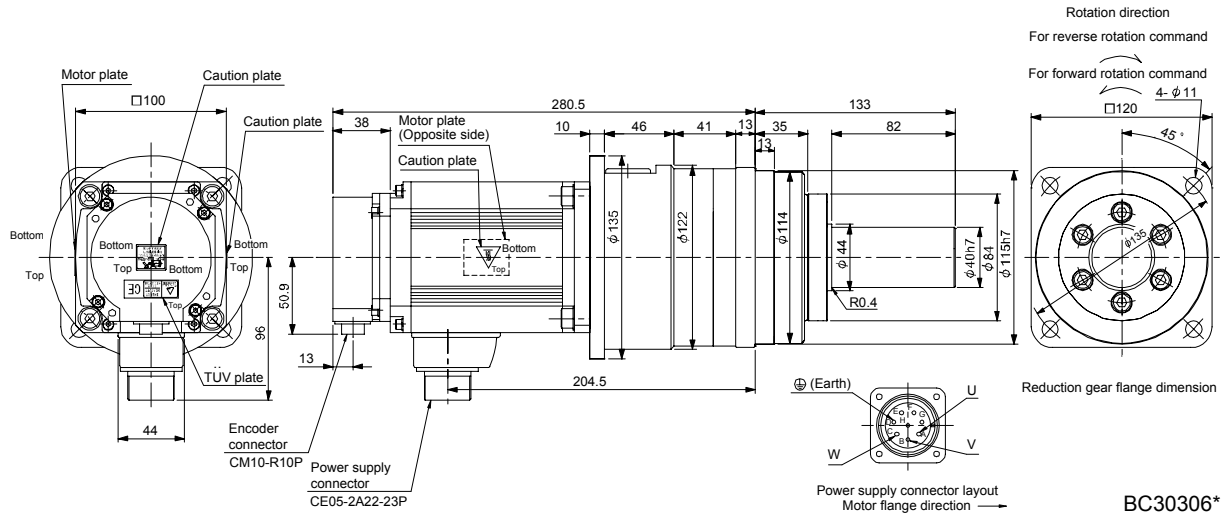

BC30306\*

Model	Output [kW]	Reduction gear model	Reduction ratio (Actual reduction ratio)	Inertia moment J [ $\times 10^{-4} \text{kg} \cdot \text{m}^2$ ] (WK <sup>2</sup> [oz · in <sup>2</sup> ])	Mass [kg] ([lb])
HC-RP153G7	1.5	HPG-50A-33-J2ADBC-S	1/33	6.60 (36.1)	24.0 (52.9)
		HPG-50A-45-J2ADBC-S	1/45		

[Unit: mm]

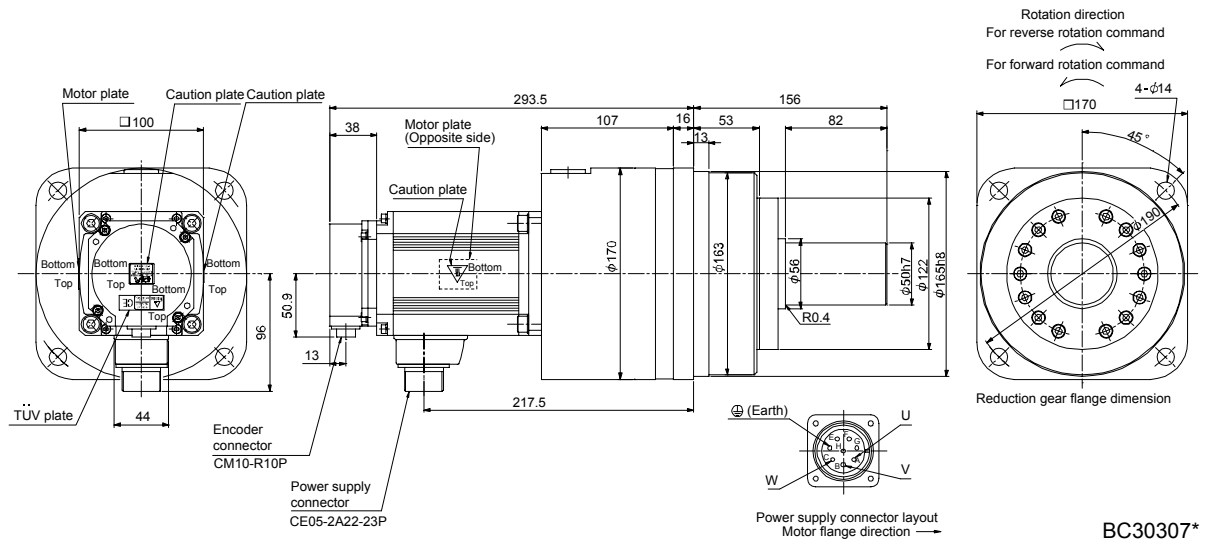

BC30307\*

## 9. HC-RP SERIES

Model	Output [kW]	Reduction gear model	Reduction ratio (Actual reduction ratio)	Inertia moment $J$ [ $\times 10^{-4} \text{kg} \cdot \text{m}^2$ ] ( $\text{WK}^2$ [oz · in <sup>2</sup> ])	Mass [kg] ([lb])
HC-RP203G7	2.0	HPG-20A-05-J2LBWS-S	1/5	3.17 (17.3)	9.1 (20.1)

[Unit: mm]

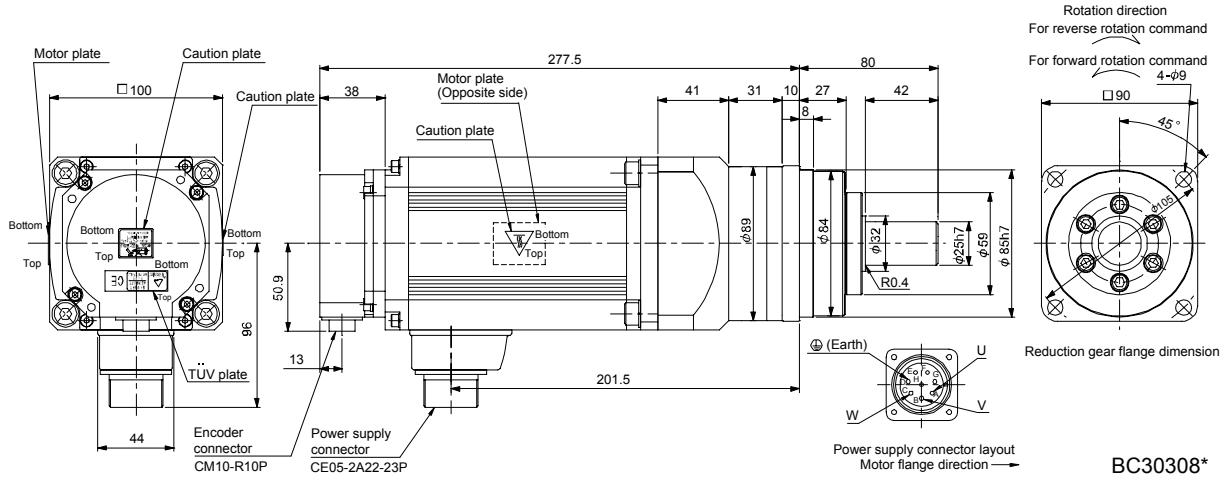

Model	Output [kW]	Reduction gear model	Reduction ratio (Actual reduction ratio)	Inertia moment $J$ [ $\times 10^{-4} \text{kg} \cdot \text{m}^2$ ] ( $\text{WK}^2$ [oz · in <sup>2</sup> ])	Mass [kg] ([lb])
HC-RP203G7	2.0	HPG-32A-11-J2NFSPS-S	1/11	5.70 (31.2)	14.1 (31.1)

[Unit: mm]

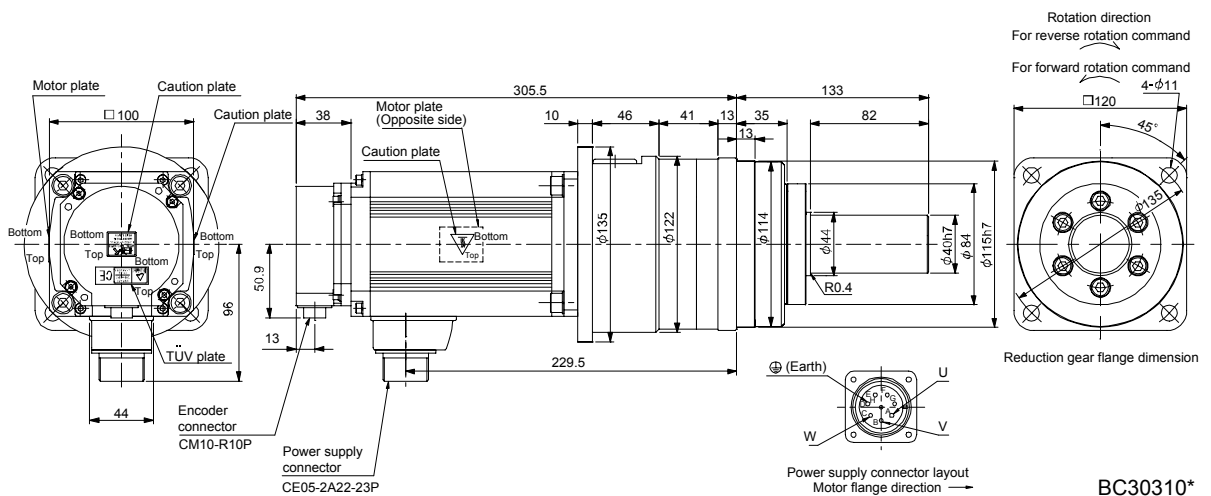

# 9. HC-RP SERIES

Model	Output [kW]	Reduction gear model	Reduction ratio (Actual reduction ratio)	Inertia moment $J [\times 10^{-4} \text{kg} \cdot \text{m}^2] (\text{WK}^2 [\text{oz} \cdot \text{in}^2])$	Mass [kg] ([lb])
HC-RP203G7	2.0	HPG-50A-21-J2ADBC-S	1/21	8.0 (43.7)	25.2 (55.6)
		HPG-50A-33-J2ADBC-S	1/33	7.0 (38.3)	
		HPG-50A-45-J2ADBC-S	1/45		

[Unit: mm]

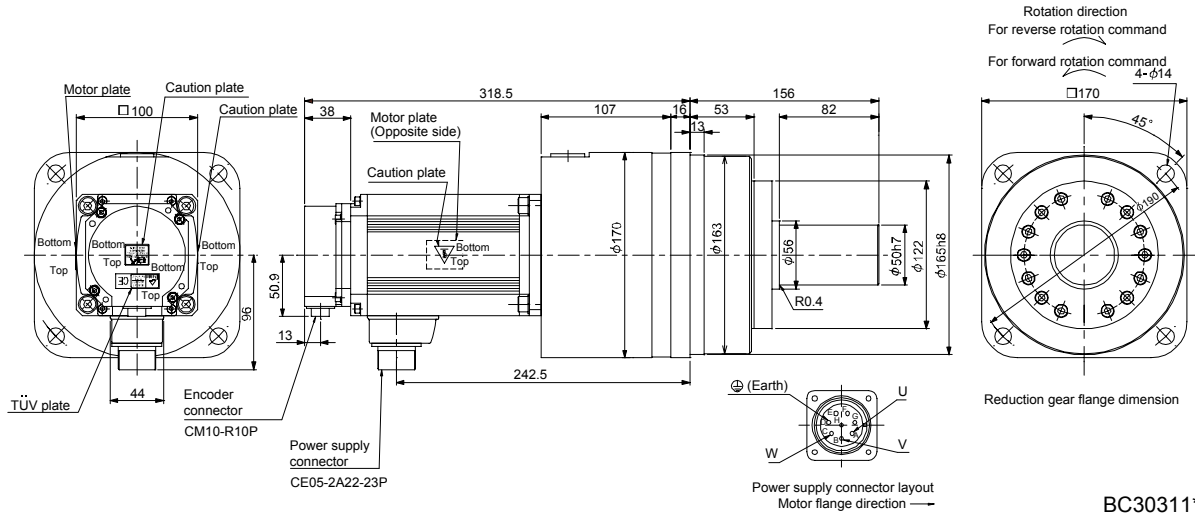

BC30311\*

Model	Output [kW]	Reduction gear model	Reduction ratio (Actual reduction ratio)	Inertia moment $J [\times 10^{-4} \text{kg} \cdot \text{m}^2] (\text{WK}^2 [\text{oz} \cdot \text{in}^2])$	Mass [kg] ([lb])
HC-RP353G7	3.5	HPG-32A-05-J2PAQS-S	1/5	13.5 (73.8)	19.9 (43.9)
		HPG-32A-11-J2PAR-S	1/11	13.1 (71.6)	20.4 (45.0)

[Unit: mm]

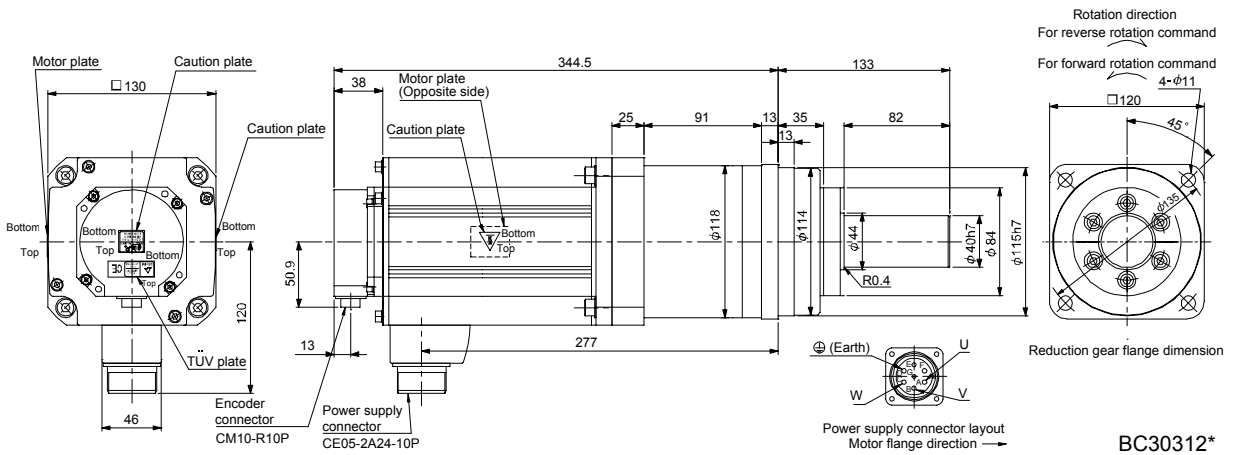

BC30312\*



## 9. HC-RP SERIES

Model	Output [kW]	Reduction gear model	Reduction ratio (Actual reduction ratio)	Inertia moment J [ $\times 10^{-4} \text{kg} \cdot \text{m}^2$ ] (WK <sup>2</sup> [oz · in <sup>2</sup> ])	Mass [kg] ([lb])
HC-RP503G7	5.0	HPG-50A-11-J2BADD-S	1/11	20.7 (113)	36.1 (79.6)
		HPG-50A-21-J2BADD-S	1/21	18.8 (103)	

[Unit: mm]

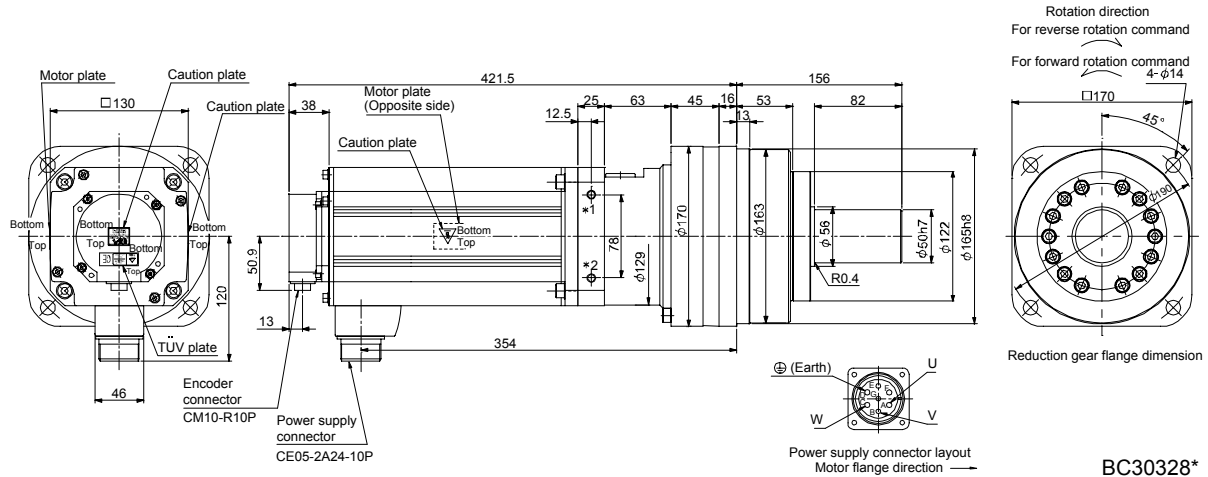

Note. \*1 and \*2 are the screw holes (M8) for the hangers.

### 9.7.6 Flange-mounting shaft output type for precision application compliant (with an electromagnetic brake)

Model	Output [kW]	Reduction gear model	Reduction ratio (Actual reduction ratio)	Brake static friction torque [N · m] (oz · in)	Inertia moment J [ $\times 10^{-4} \text{kg} \cdot \text{m}^2$ ] (WK <sup>2</sup> [oz · in <sup>2</sup> ])	Mass [kg] ([lb])
HC-RP103BG7	1.0	HPG-20A-05-J2LBWS-S	1/5	7.0 (991)	2.72 (14.9)	8.9 (19.6)
		HPG-20A-11-J2LBXS-S	1/11		2.60 (14.2)	9.1 (20.1)

[Unit: mm]

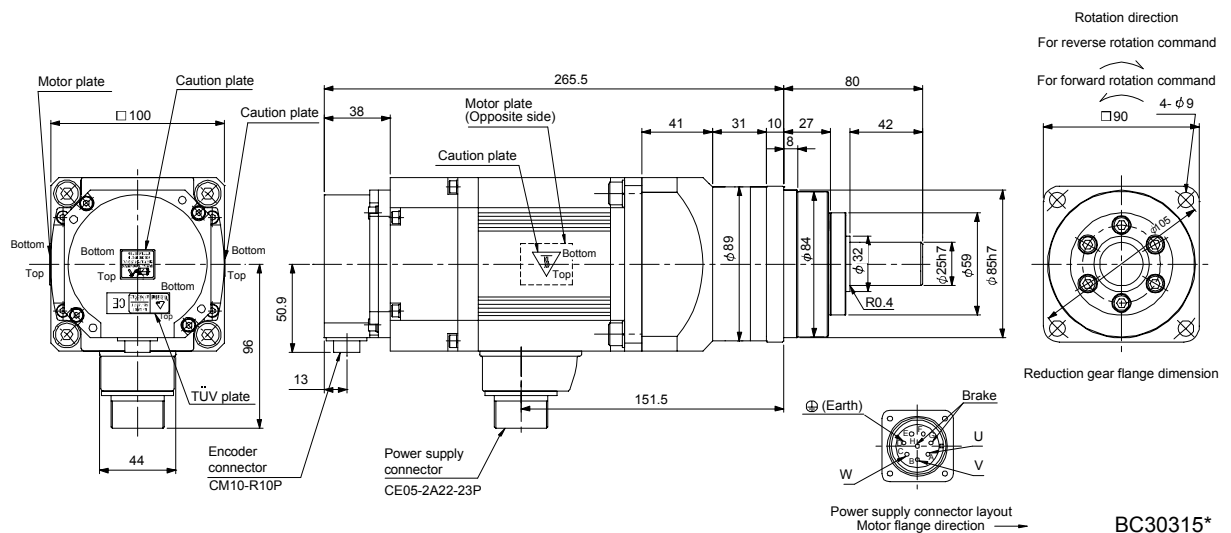

# 9. HC-RP SERIES

Model	Output [kW]	Reduction gear model	Reduction ratio (Actual reduction ratio)	Brake static friction torque [N · m] (oz · in)	Inertia moment J [ $\times 10^{-4} \text{kg} \cdot \text{m}^2$ ] ( $\text{WK}^2$ [oz · in <sup>2</sup> ])	Mass [kg] (lb)
HC-RP103BG7	1.0	HPG-32A-21-J2NFSYS-S	1/21	7.0 (991)	4.75 (26.0)	13.9 (30.6)
		HPG-32A-33-J2NFSZS-S	1/33		4.55 (24.9)	

[Unit: mm]

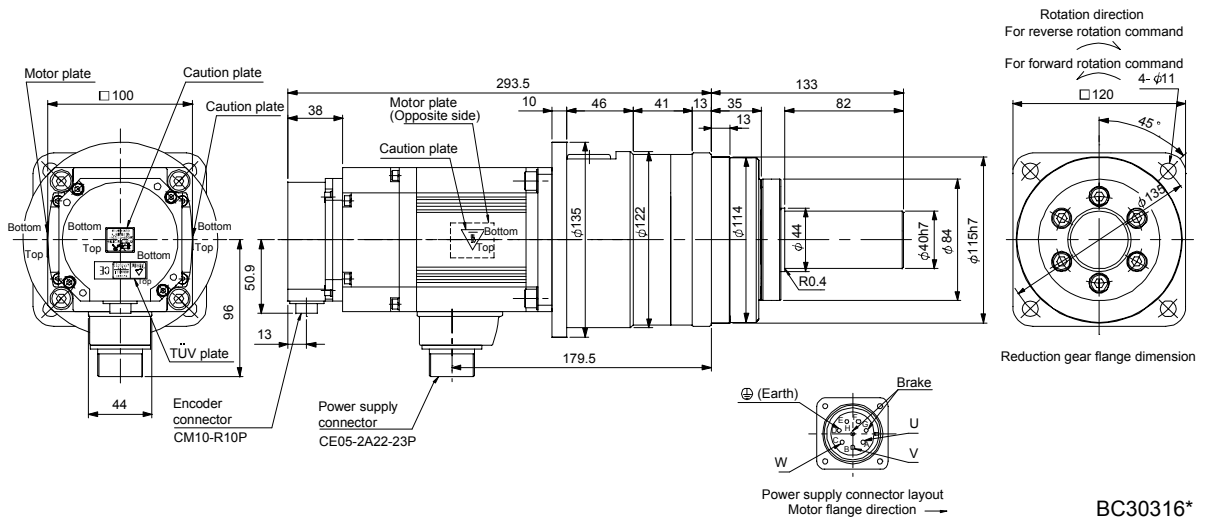

Model	Output [kW]	Reduction gear model	Reduction ratio (Actual reduction ratio)	Brake static friction torque [N · m] (oz · in)	Inertia moment J [ $\times 10^{-4} \text{kg} \cdot \text{m}^2$ ] ( $\text{WK}^2$ [oz · in <sup>2</sup> ])	Mass [kg] (lb)
HC-RP103BG7	1.0	HPG-50A-45-J2ADBC-S	1/45	7.0 (991)	6.55 (35.8)	25.0 (55.1)

[Unit: mm]

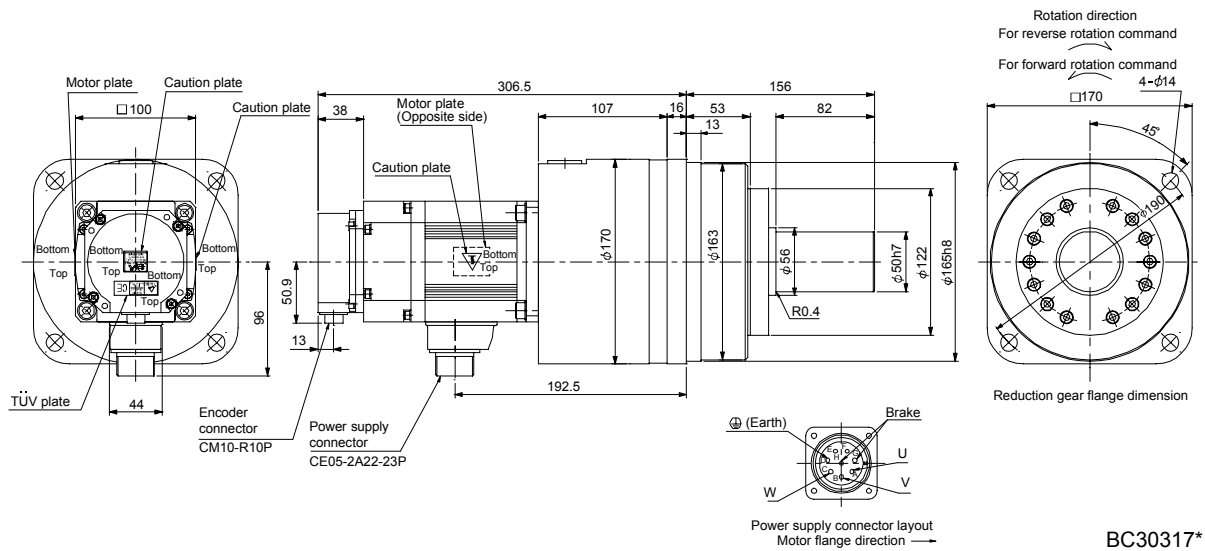



# 9. HC-RP SERIES

Model	Output [kW]	Reduction gear model	Reduction ratio (Actual reduction ratio)	Brake static friction torque [N · m] [oz · in]	Inertia moment J [ $\times 10^{-4}$ kg · m <sup>2</sup> ] (WK <sup>2</sup> [oz · in <sup>2</sup> ])	Mass [kg] (lb)
HC-RP153BG7	1.5	HPG-20A-05-J2LBWS-S	1/5	7.0 (991)	3.12 (17.1)	9.9 (21.8)

[Unit: mm]

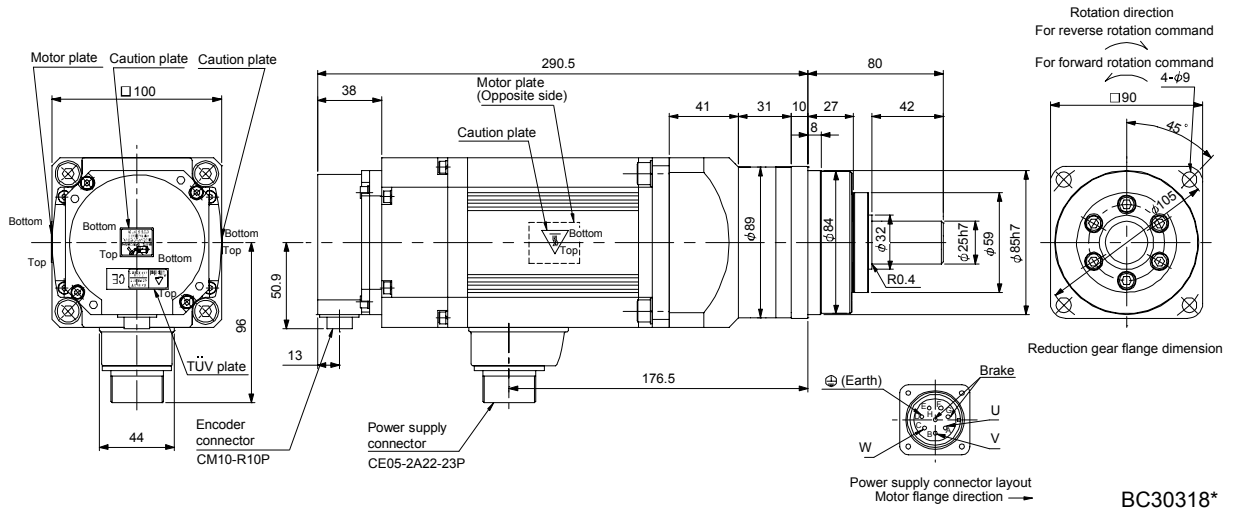

Model	Output [kW]	Reduction gear model	Reduction ratio (Actual reduction ratio)	Brake static friction torque [N · m] [oz · in]	Inertia moment J [ $\times 10^{-4}$ kg · m <sup>2</sup> ] (WK <sup>2</sup> [oz · in <sup>2</sup> ])	Mass [kg] (lb)
HC-RP153BG7	1.5	HPG-32A-11-J2NFSPS-S	1/11	7.0 (991)	5.65 (30.9)	14.9 (32.8)
		HPG-32A-21-J2NFSYS-S	1/21		5.15 (28.2)	

[Unit: mm]

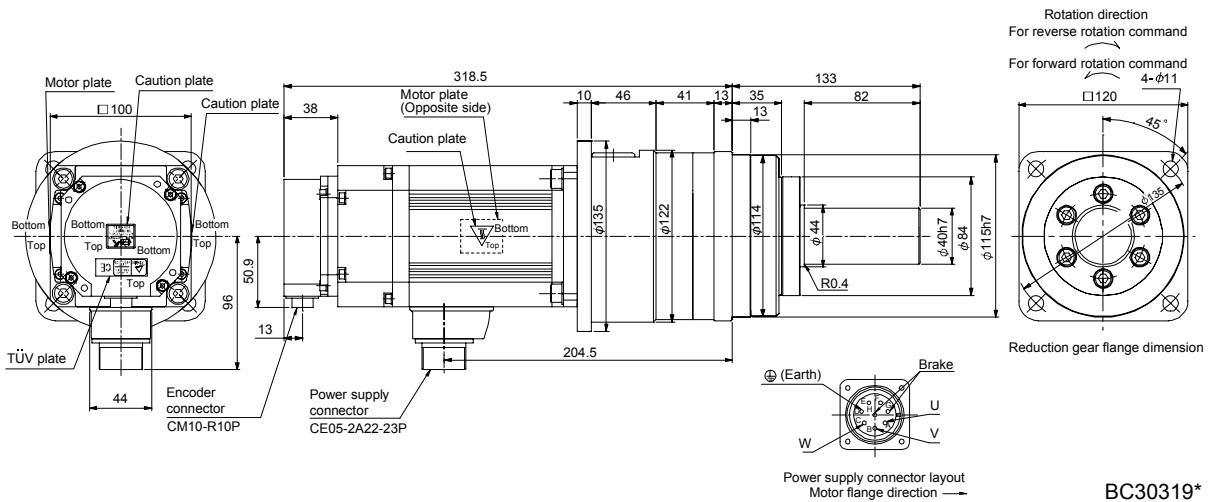

# 9. HC-RP SERIES

Model	Output [kW]	Reduction gear model	Reduction ratio (Actual reduction ratio)	Brake static friction torque [N · m] ([oz · in])	Inertia moment J [ $\times 10^{-4} \text{kg} \cdot \text{m}^2$ ] (WK <sup>2</sup> [oz · in <sup>2</sup> ])	Mass [kg] ([lb])
HC-RP153BG7	1.5	HPG-50A-33-J2ADBC-S	1/33	7.0 (991)	6.95 (38.0)	26.0 (57.3)
		HPG-50A-45-J2ADBC-S	1/45			

[Unit: mm]

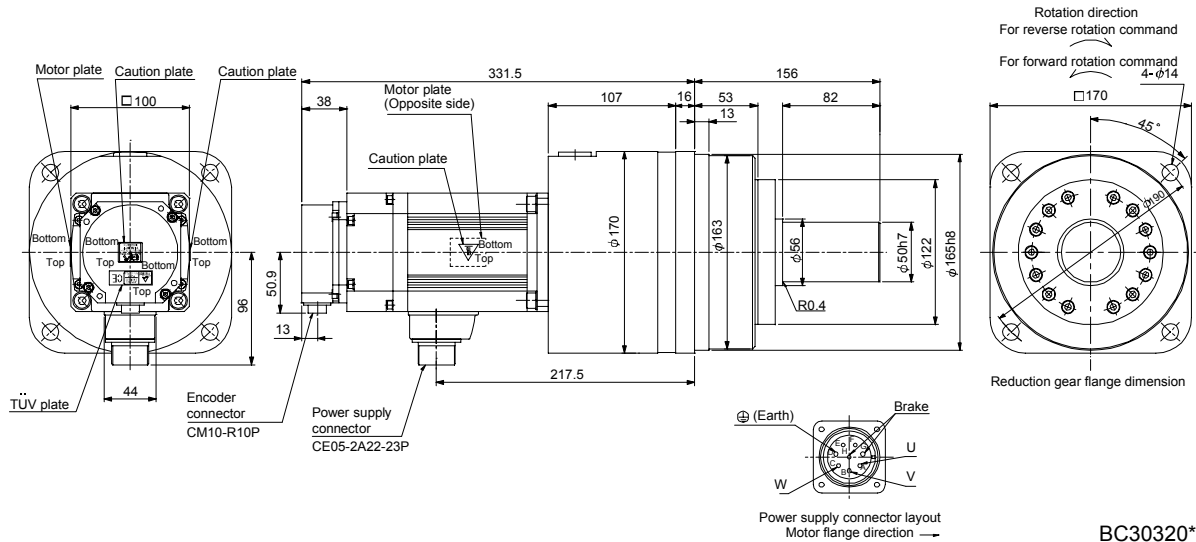

BC30320\*

Model	Output [kW]	Reduction gear model	Reduction ratio (Actual reduction ratio)	Brake static friction torque [N · m] ([oz · in])	Inertia moment J [ $\times 10^{-4} \text{kg} \cdot \text{m}^2$ ] (WK <sup>2</sup> [oz · in <sup>2</sup> ])	Mass [kg] ([lb])
HC-RP203BG7	2.0	HPG-20A-05-J2LBWS-S	1/5	7.0 (991)	3.52 (19.2)	11.2 (24.7)

[Unit: mm]

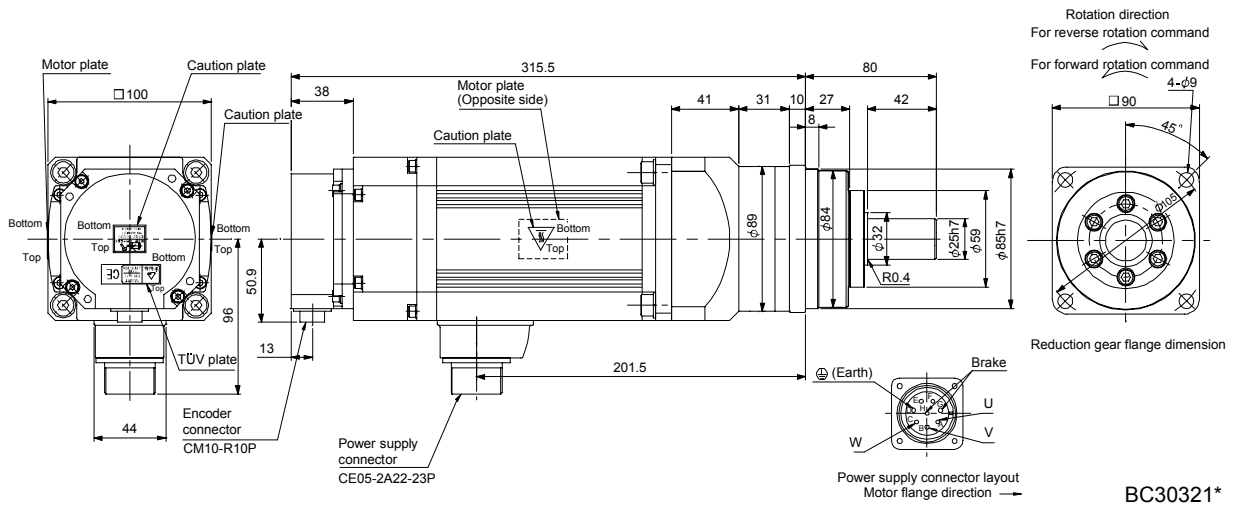

BC30321\*

# 9. HC-RP SERIES

Model	Output [kW]	Reduction gear model	Reduction ratio (Actual reduction ratio)	Brake static friction torque [N · m] ([oz · in])	Inertia moment J [ $\times 10^{-4}$ kg · m <sup>2</sup> ] (WK <sup>2</sup> [oz · in <sup>2</sup> ])	Mass [kg] ([lb])
HC-RP203BG7	2.0	HPG-32A-11-J2NFSPS-S	1/11	7.0 (991)	6.05 (33.1)	16.2 (35.7)

[Unit: mm]

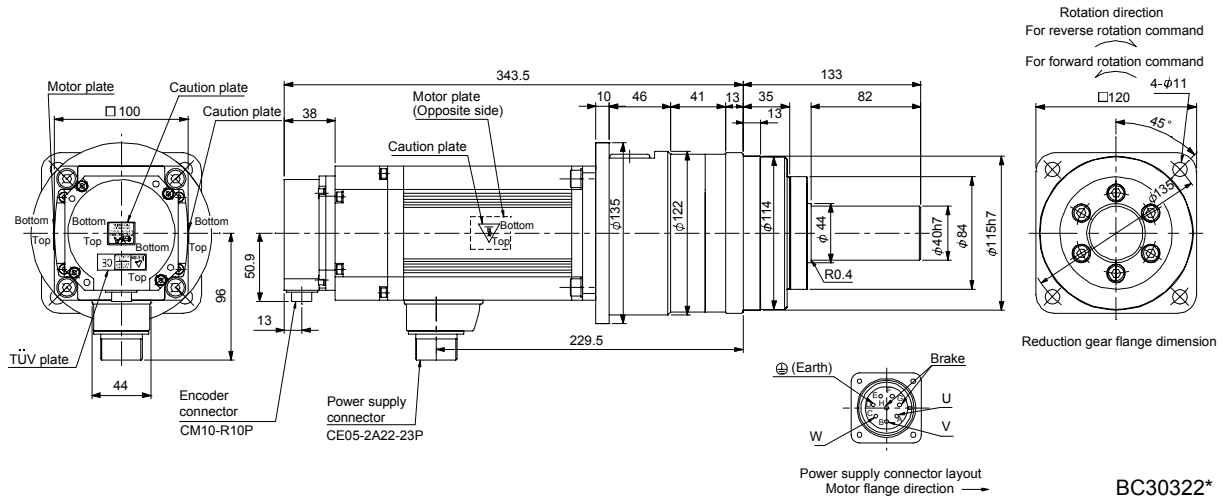

Model	Output [kW]	Reduction gear model	Reduction ratio (Actual reduction ratio)	Brake static friction torque [N · m] ([oz · in])	Inertia moment J [ $\times 10^{-4}$ kg · m <sup>2</sup> ] (WK <sup>2</sup> [oz · in <sup>2</sup> ])	Mass [kg] ([lb])
HC-RP203BG7	2.0	HPG-50A-21-J2ADBC-S	1/21	7.0 (991)	8.35 (45.7)	27.3 (60.2)
		HPG-50A-33-J2ADBC-S	1/33		7.35 (40.2)	
		HPG-50A-45-J2ADBC-S	1/45			

[Unit: mm]

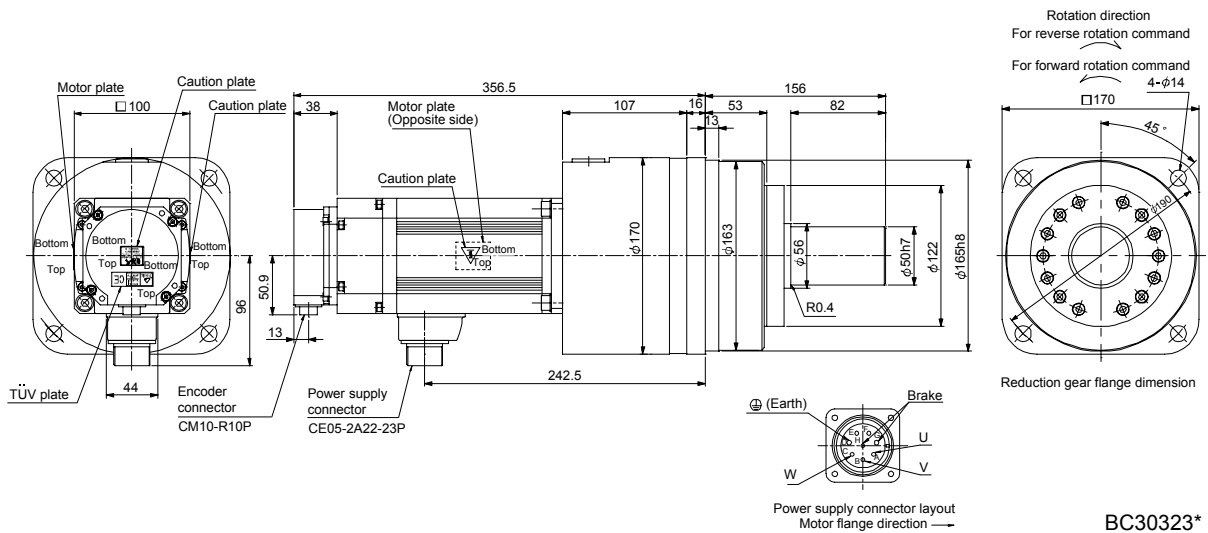

# 9. HC-RP SERIES

Model	Output [kW]	Reduction gear model	Reduction ratio (Actual reduction ratio)	Brake static friction torque [N · m] ([oz · in])	Inertia moment J [ $\times 10^{-4} \text{kg} \cdot \text{m}^2$ ] ( $\text{WK}^2$ [oz · in <sup>2</sup> ])	Mass [kg] ([lb])
HC-RP353BG7	3.5	HPG-32A-05-J2PAQS-S	1/5	16.7 (2370)	17.0 (92.9)	22.9 (50.5)
		HPG-32A-11-J2PAR-S	1/11		16.6 (90.8)	23.4 (51.6)

[Unit: mm]

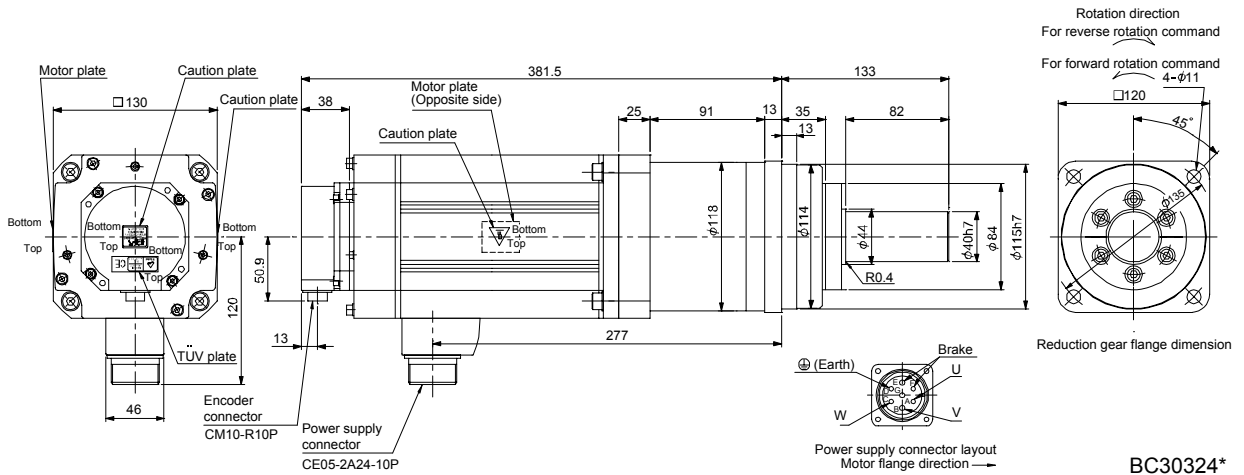

Model	Output [kW]	Reduction gear model	Reduction ratio (Actual reduction ratio)	Brake static friction torque [N · m] ([oz · in])	Inertia moment J [ $\times 10^{-4} \text{kg} \cdot \text{m}^2$ ] ( $\text{WK}^2$ [oz · in <sup>2</sup> ])	Mass [kg] ([lb])
HC-RP353BG7	3.5	HPG-50A-21-J2BADD-S	1/21	16.7 (2370)	18.6 (102)	34.1 (75.2)
		HPG-50A-33-J2BADD-S	1/33		17.6 (96.2)	

[Unit: mm]

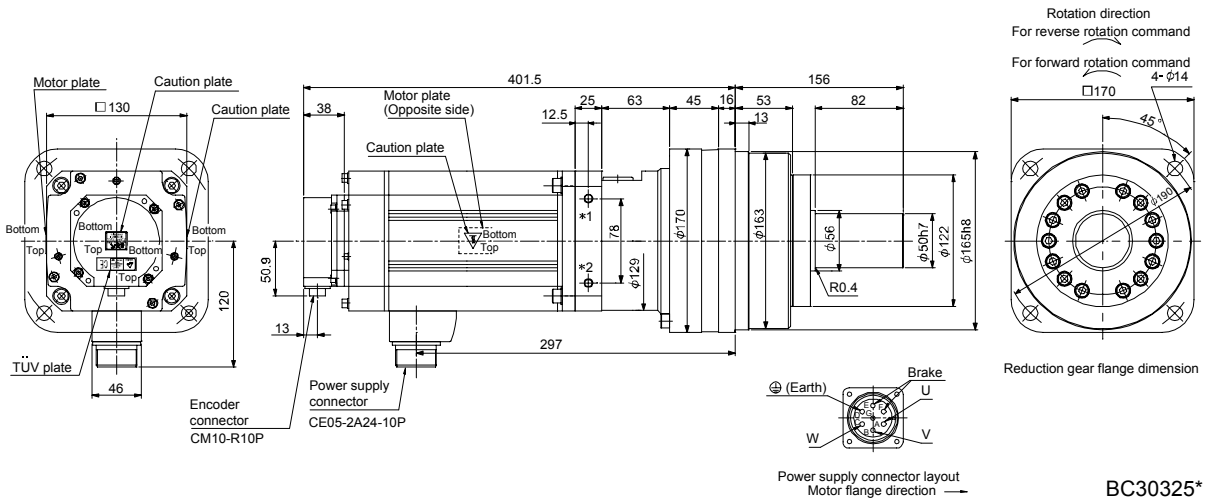

Note. \*1 and \*2 are the screw holes (M8) for the hangers.

# 9. HC-RP SERIES

Model	Output [kW]	Reduction gear model	Reduction ratio (Actual reduction ratio)	Brake static friction torque [N · m] [oz · in]	Inertia moment J [ $\times 10^{-4}$ kg · m <sup>2</sup> ] (WK <sup>2</sup> [oz · in <sup>2</sup> ])	Mass [kg] (lb)
HC-RP503BG7	5.0	HPG-32A-05-J2PAQS-S	1/5	16.7 (2370)	20.7 (113)	28.9 (63.7)

[Unit: mm]

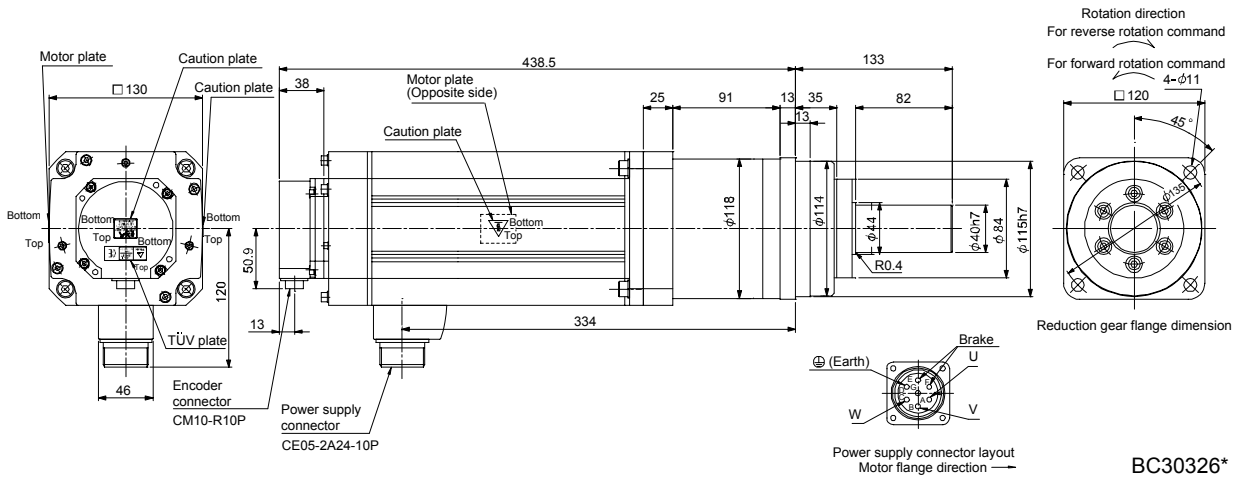

Model	Output [kW]	Reduction gear model	Reduction ratio (Actual reduction ratio)	Brake static friction torque [N · m] [oz · in]	Inertia moment J [ $\times 10^{-4}$ kg · m <sup>2</sup> ] (WK <sup>2</sup> [oz · in <sup>2</sup> ])	Mass [kg] (lb)
HC-RP503BG7	5.0	HPG-50A-11-J2BADD-S	1/11	16.7 (2370)	24.2 (132)	40.1 (88.4)
		HPG-50A-21-J2BADD-S	1/21		22.3 (122)	

[Unit: mm]

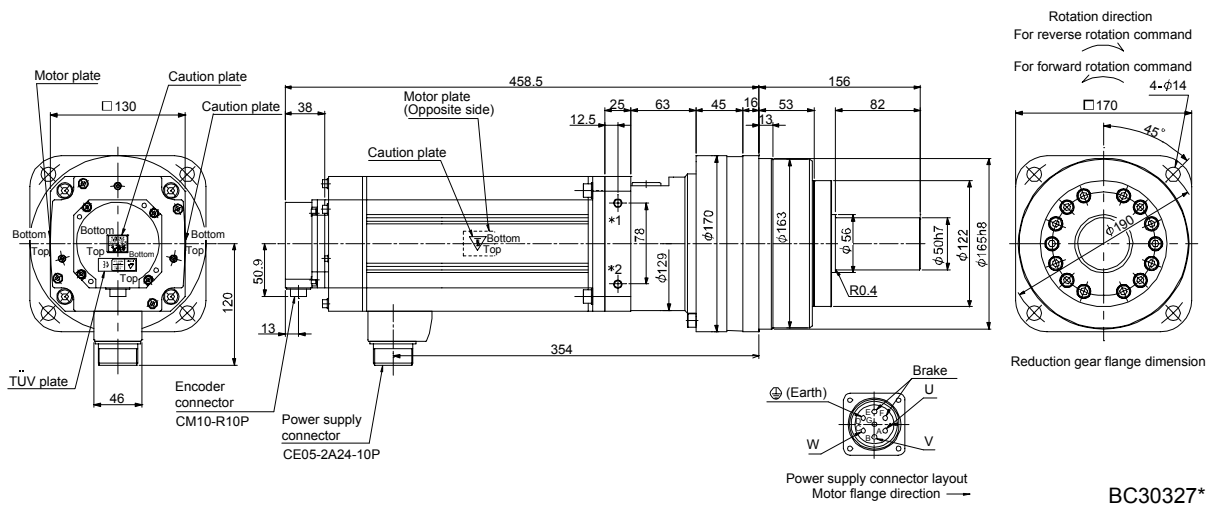

Note. \*1 and \*2 are the screw holes (M8) for the hangers.

## 9. HC-RP SERIES

---

### 9.8 Servo motor with oil seal

For the servo motor with oil seal, the oil seal prevents the entry of oil into the servo motor. Install the servo motor horizontally, and set the oil level in the gear box to be lower than the oil seal lip always.

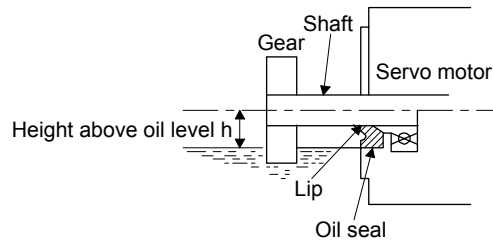

Servo motor	Height above oil level h [mm]
HC-RP103 to 503	20



# 10. HC-UP SERIES

## 10. HC-UP SERIES

This chapter provides information on the servo motor specifications and characteristics. When using the HC-UP series servo motor, always read the Safety Instructions in the beginning of this manual and chapters 1 to 4, in addition to this chapter.

### 10.1 Model name make up

The following describes what each block of a model name indicates. Note that not all the combinations of the symbols exist.

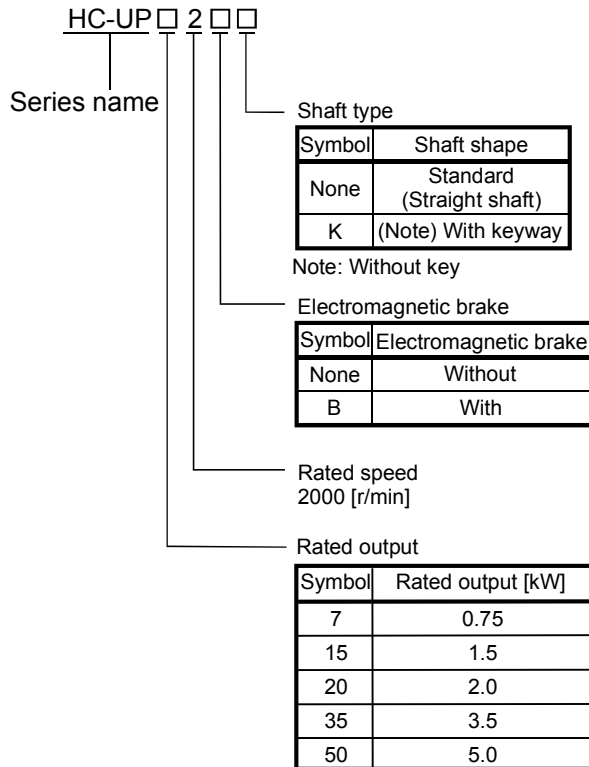

Appearance

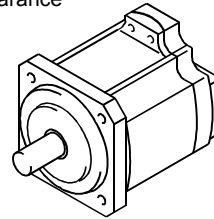



## 10. HC-UP SERIES

### 10.2 Standard specifications

#### 10.2.1 Standard specifications list

Item		Servo motor	HC-UP 2000r/min series (Flat type • middle capacity)				
			72	152	202	352	502
Applicable servo amplifier/drive unit	MR-J3-□A/B/B-RJ006/T		70	200	350	500	500
Continuous running duty (Note 1)	Rated output [kW]		0.75	1.5	2.0	3.5	5.0
	Rated torque	[N • m]	3.58	7.16	9.55	16.7	23.9
		[oz • in]	507	1020	1350	2370	3390
Rated speed (Note 1)		[r/min]	2000				
Maximum speed		[r/min]	3000			2500	
Instantaneous permissible speed		[r/min]	3450			2875	
Maximum torque		[N • m]	10.7	21.6	28.5	50.1	71.6
		[oz • in]	1520	3060	4040	7100	10100
Power rate at continuous rated torque		[kW/s]	12.3	23.2	23.9	36.5	49.6
Inertia moment (Note 3)	J	[ $\times 10^{-4}$ kg • m <sup>2</sup> ]	10.4	22.1	38.2	76.5	115
	WK <sup>2</sup>	[oz • in <sup>2</sup> ]	56.9	121	209	418	629
Recommended ratio of load inertia moment to servo motor shaft inertia moment (Note 2)			15 times or less				
Power supply capacity			Refer to "Power supply equipment capacity and generated loss of servo amplifiers" in Servo Amplifier Instruction Manual.				
Rated current		[A]	5.4	9.7	14	23	28
Maximum current		[A]	16	29	42	69	84
Speed/position detector			Encoder common to absolute position and incremental detection systems (Resolution per servo motor 1 rotation : 262144 pulse/rev)				
Accessory			Oil seal				
Insulation class			155(F)				
Structure			Totally-enclosed, natural-cooling (IP rating: IP65 (Note 4))				
Environmental conditions (Note 5)	Ambient temperature	Operation	[°C]	0 to 40 (non-freezing)			
			[°F]	32 to 104 (non-freezing)			
		Storage	[°C]	-15 to 70 (non-freezing)			
			[°F]	5 to 158 (non-freezing)			
	Ambient humidity	Operation		80%RH or less (non-condensing)			
		Storage		90%RH or less (non-condensing)			
	Ambience		Indoors (no direct sunlight) Free from corrosive gas, flammable gas, oil mist, dust and dirt.				
	Altitude		Max.1000m above sea level				
Vibration resistance (Note 6)		[m/s <sup>2</sup> ]	X, Y: 24.5		X: 24.5 Y: 49		
Vibration rank (Note 7)			V10				
Permissible load for the shaft (Note 8)	L	[mm]	55		65		
		Radial	[N]	637	882	1176	
	[lb]		143	198	264		
	Thrust	[N]	490	784			
		[lb]	110	176			
Mass (Note 3)		[kg]	8.0	11	16	20	24
		[lb]	17.6	24.3	35.3	44.1	52.9

# 10. HC-UP SERIES

Note 1. When the power supply voltage drops, we cannot guarantee the out put and rated speed.

2. If the load inertia moment ratio exceeds the indicated value, please consult your local sales office.
3. Refer to the outline dimension drawing for the servo motor with an electromagnetic brake.
4. Except for the shaft – through portion.
5. In the environment where the servo motor is exposed to oil mist, oil and/or water, the servo motor of the standard specifications may not be usable. Contact your local sales office.
6. The vibration direction is as shown in the figure. The value is the one at the part that indicates the maximum value (normally the opposite-to-load side bracket). When the servo motor stops, fretting is likely to occur at the bearing. Therefore, suppress the vibration to about half of the permissible value.

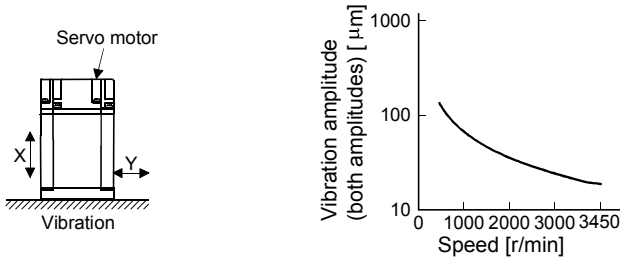

7. V10 indicates that the amplitude of a single servo motor is 10 $\mu\text{m}$  or less. The following figure shows the servo motor installation position for measurement and the measuring position.

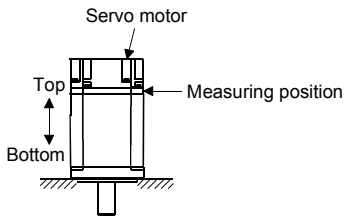

8. For the symbols in the table, refer to the following diagram: Do not subject the shaft to load greater than this value. The values in the table assume that the loads work singly.

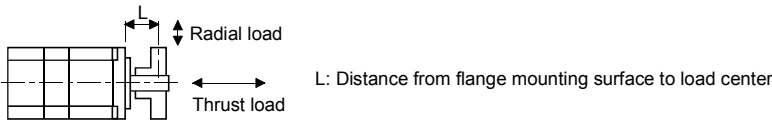

## 10. HC-UP SERIES

### 10.2.2 Torque characteristics

POINT
<ul style="list-style-type: none"> <li>For machines which produce unbalance torque, e.g. vertical lift applications, it is recommended to use the servo motor so that the unbalance torque will be within 70% of the rated torque.</li> </ul>

When the power input of the servo amplifier are 3-phase 200VAC or 1-phase 230VAC, the torque characteristic is indicated by the heavy line. For the 1-phase 200VAC power supply, part of the torque characteristic is indicated by the thin line. HC-UP72 supports 1-phase power supply input.

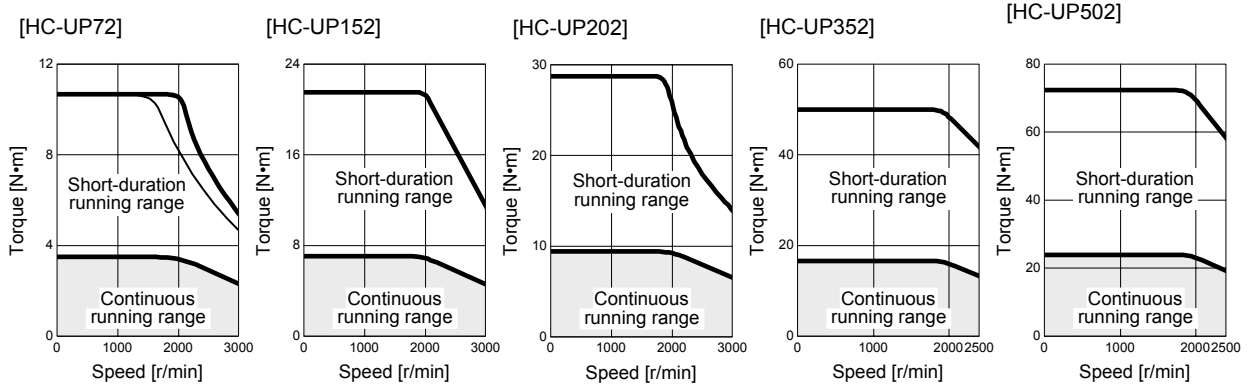

## 10. HC-UP SERIES

### 10.3 Electromagnetic brake



**CAUTION**

- The electromagnetic brake is provided to prevent a drop at a power failure or servo alarm occurrence during vertical drive or to hold a shaft at a stop. Do not use it for normal braking (including braking at servo lock).
- Before performing the operation, be sure to confirm that the electromagnetic brake operates properly.
- The operation time of the electromagnetic brake differs depending on the power supply circuit you use. Be sure to check the operation delay time with a real machine.

The characteristics of the electromagnetic brake provided for the servo motor with an electromagnetic brake are indicated below.

Item	Servo motor	HC-UP series	
		72B · 152B	202B to 502B
Type (Note 1)		Spring-loaded safety brake	
Rated voltage (Note 4)		24V <sup>0</sup> <sub>-10%</sub> DC	
Capacity	[W] at 20°C (68°F)	19	34
Coil resistance (Note 6)	[Ω]	29.0	17.0
Inductance (Note 6)	[H]	0.8	1.17
Brake static friction torque	[N · m]	8.5	44
	[oz · in]	1200	6230
Release delay time (Note 2)	[s]	0.04	0.1
Braking delay time (Note 2)	[s] DC off	0.03	0.03
Permissible braking work	Per braking [J]	400	4500
	Per hour [J]	4000	45000
Brake looseness at servo motor shaft (Note 5)	[degrees]	0.2 to 0.6	0.2 to 0.6
Brake life (Note 3)	Number of braking cycles [times]	20000	20000
	Work per braking [J]	200	1000
Selection example of surge absorbers to be used (Note 7, 8)	For the suppressed voltage 125V	TND20V-680KB	
	For the suppressed voltage 350V	TND10V-221KB	

Note 1. There is no manual release mechanism. When it is necessary to hand-turn the servo motor shaft for machine centering, etc., use a separate 24VDC power supply to release the brake electrically.

2. The value for initial ON gap at 20°C (68°F).

3. The brake gap will increase as the brake lining wears, but the gap is not adjustable. The brake life indicated is the number of braking cycles after which adjustment will be required.

4. Always prepare a power supply exclusively used for the electromagnetic brake.

5. The above values are typical initial values and not guaranteed values.

6. These values are measured values and not guaranteed values.

7. Select the electromagnetic brake control relay properly, considering the characteristics of the electromagnetic brake and surge absorber.

8. Manufactured by Nippon Chemi-Con Corporation.

## 10. HC-UP SERIES

### 10.4 Servo motors with special shafts

The servo motors with special shafts indicated by the symbol (K) in the table is available. K is the symbols attached to the servo motor model names.

Servo motor	Shaft shape
	Keyway shaft (without key)
HC-UP	K

Servo motor	Variable dimensions							
	S	R	Q	W	QK	QL	U	r
HC-UP72(B)K	22h6	55	50	$6_{-0.036}^0$	42	3	$3.5_{+0.1}^0$	3
HC-UP152(B)K	28h6	55	50	$8_{-0.036}^0$	40	3	$4_{+0.2}^0$	4
HC-UP202(B)K to 502(B)K	$35_{+0.010}^0$	65	60	$10_{-0.036}^0$	50	5	$5_{+0.2}^0$	5

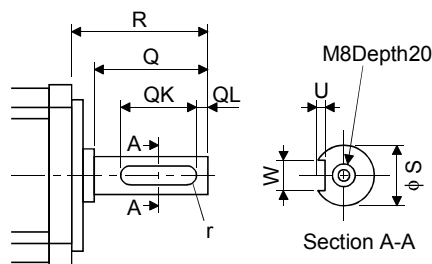

### 10.5 Wiring option

Connector sets to use in power supply connector or brake connector are available as option.

For details of each connector set, cable and connector set to use in wiring to encoder, refer to the Servo Amplifier Instruction Manual for using.

Make sure to use the following power supply connector set for conforming to the IEC/EN compliant.

Servo motor	Power supply connector set	Brake connector set
HC-UP72 * 152	MR-PWCNS1 Configuration products Plug: CE05-6A22-23SD-D-BSS Cable clamp: CE3057-12A-2-D (DDK)	Shared with the one for power supply (Note)
HC-UP202 to 502	MR-PWCNS2 Configuration products Plug: CE05-6A24-10SD-D-BSS Cable clamp: CE3057-16A-2-D (DDK)	MR-BKCN Configuration products Plug: D/MS3106A10SL-4S (D190) (DDK) Connector for cable: YSO10-5 to 8 (Daiwa Dengyo)

Note. Brake connector is not required since the power supply connector has a pin assigned for electromagnetic brake.

# 10. HC-UP SERIES

## 10.6 Outline dimension drawings

The dimensions without tolerances are reference dimensions.

Inertia moment on the table is the value calculated by converting the total value of inertia moment for servo motor, electromagnetic brake and decelerator with servo motor shaft.

### 10.6.1 Standard (without an electromagnetic brake)

Model	Output [kW]	Inertia moment J [ $\times 10^{-4}$ kg · m <sup>2</sup> ] (WK <sup>2</sup> [oz · in <sup>2</sup> ])	Mass [kg] (lb)
HC-UP72	0.75	10.4 (56.9)	8.0 (17.6)

[Unit: mm]

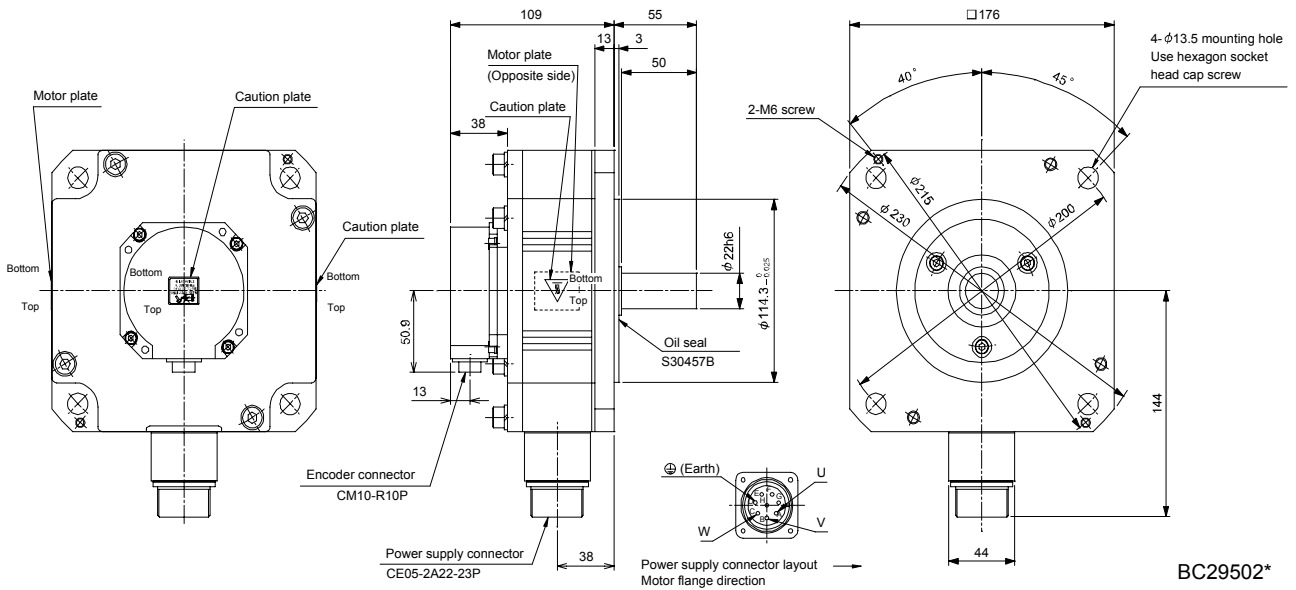

Model	Output [kW]	Inertia moment J [ $\times 10^{-4}$ kg · m <sup>2</sup> ] (WK <sup>2</sup> [oz · in <sup>2</sup> ])	Mass [kg] (lb)
HC-UP152	1.5	22.1 (121)	11 (24.3)

[Unit: mm]

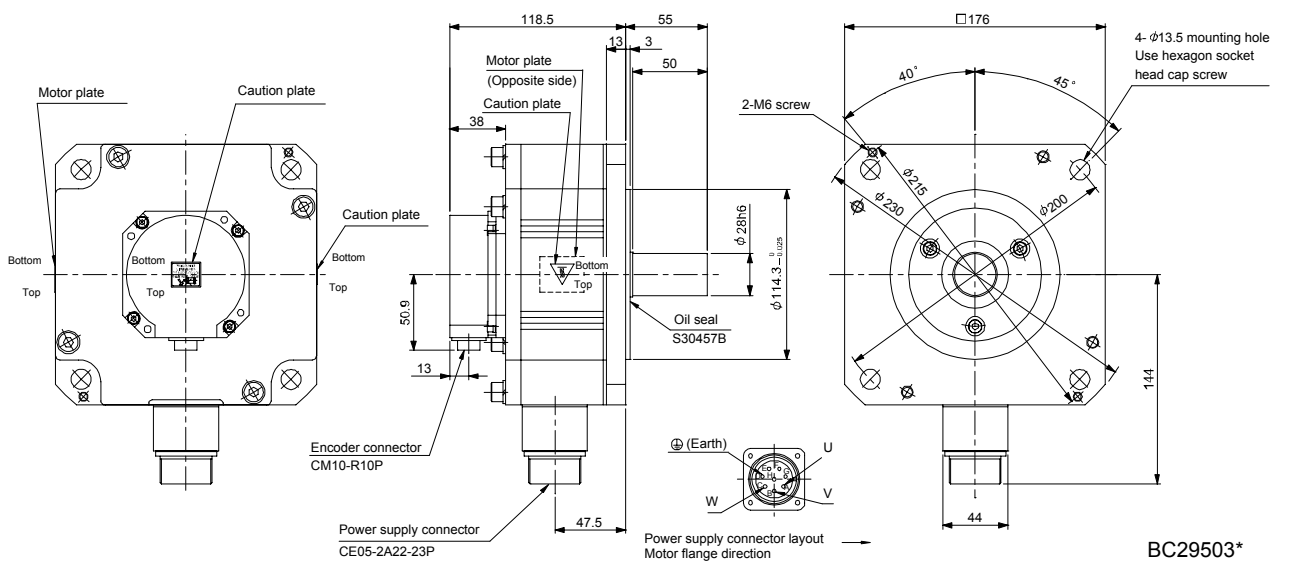

# 10. HC-UP SERIES

Model	Output [kW]	Inertia moment J [ $\times 10^{-4}$ kg $\cdot$ m <sup>2</sup> ] (WK <sup>2</sup> [oz $\cdot$ in <sup>2</sup> ])	Mass [kg] (lb)
HC-UP202	2.0	38.2 (209)	16 (35.3)

[Unit: mm]

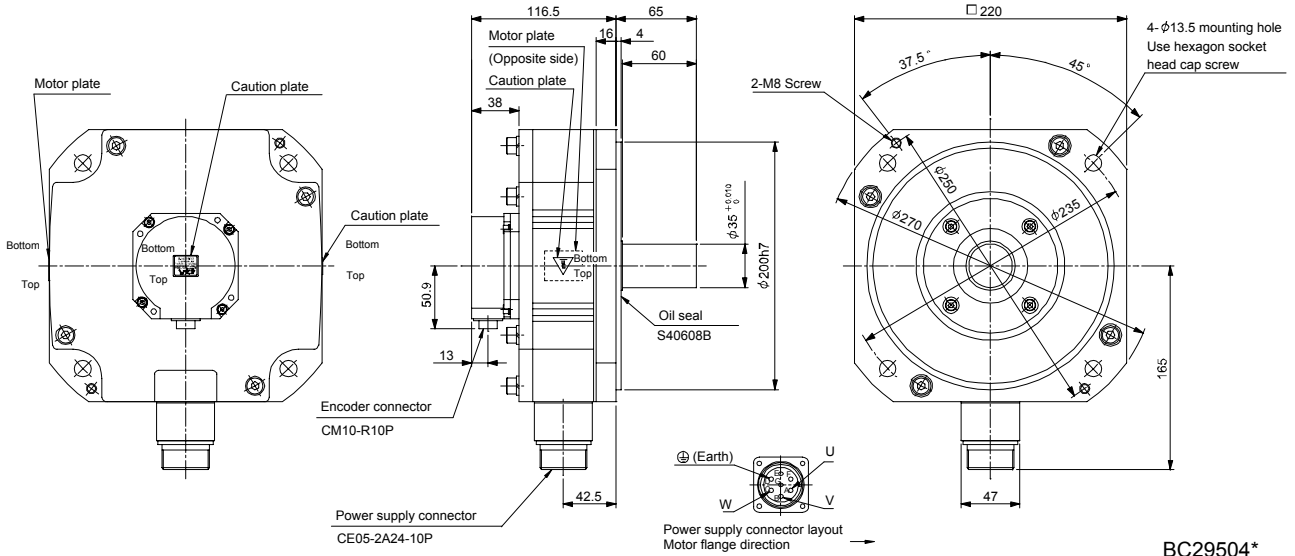

BC29504\*

Model	Output [kW]	Inertia moment J [ $\times 10^{-4}$ kg $\cdot$ m <sup>2</sup> ] (WK <sup>2</sup> [oz $\cdot$ in <sup>2</sup> ])	Mass [kg] (lb)
HC-UP352	3.5	76.5 (418)	20 (44.1)

[Unit: mm]

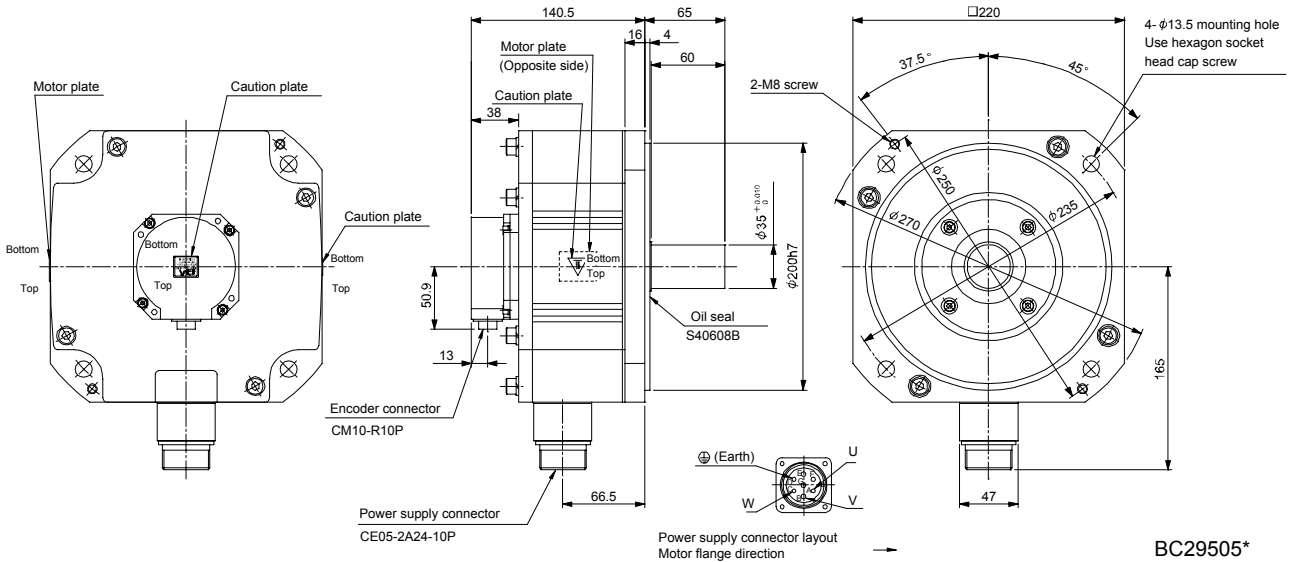

BC29505\*

# 10. HC-UP SERIES

Model	Output [kW]	Inertia moment J [ $\times 10^{-4}$ kg · m <sup>2</sup> ] (WK <sup>2</sup> [oz · in <sup>2</sup> ])	Mass [kg] (lb)
HC-UP502	5.0	115 (629)	24 (52.9)

[Unit: mm]

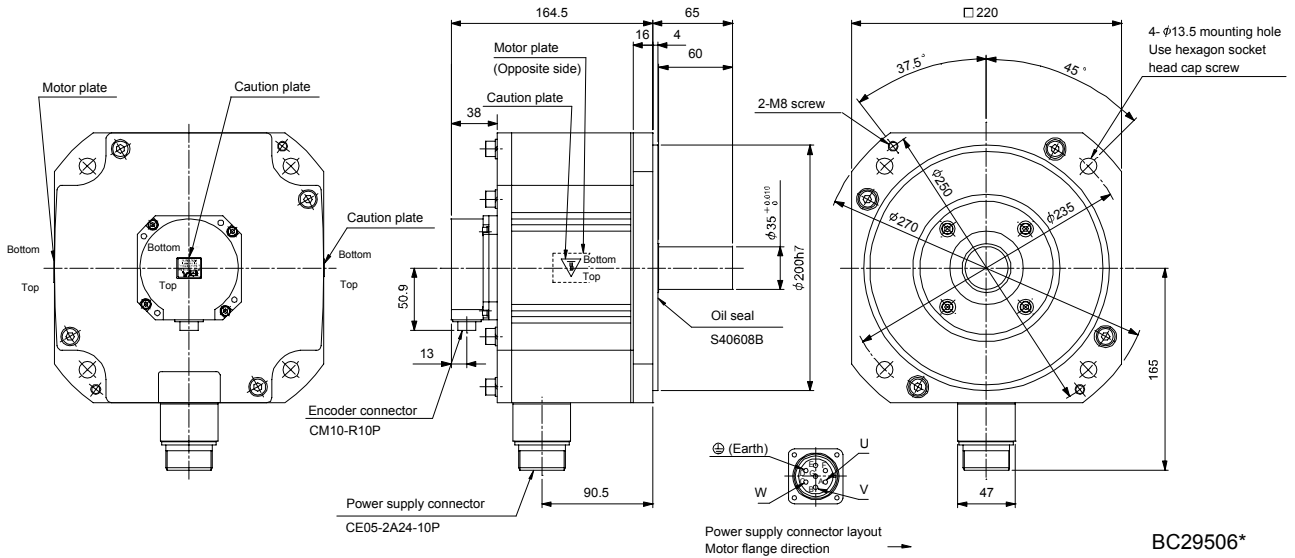

BC29506\*

## 10.6.2 With an electromagnetic brake

Model	Output [kW]	Brake static friction torque [N · m] (oz · in)	Inertia moment J [ $\times 10^{-4}$ kg · m <sup>2</sup> ] (WK <sup>2</sup> [oz · in <sup>2</sup> ])	Mass [kg] (lb)
HC-UP72B	0.75	8.5 (1200)	12.5 (68.3)	10 (22.0)

[Unit: mm]

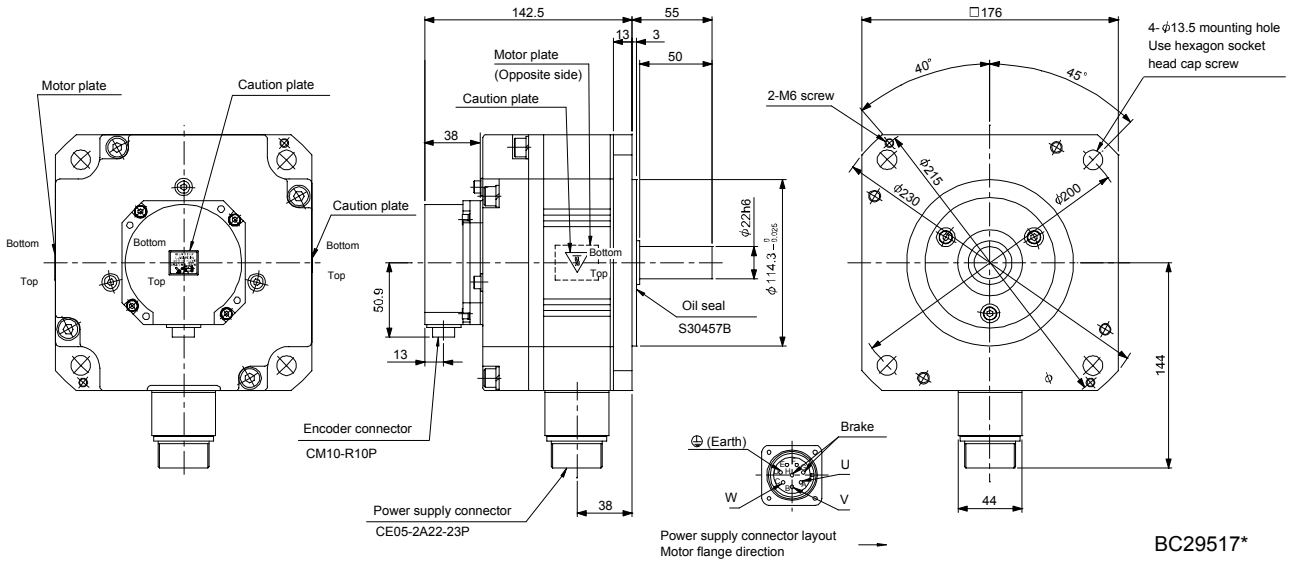

BC29517\*





# 10. HC-UP SERIES

Model	Output [kW]	Brake static friction torque [N · m] ([oz · in])	Inertia moment $J [ \times 10^{-4} \text{kg} \cdot \text{m}^2 ]$ ( $\text{WK}^2$ [oz · in <sup>2</sup> ])	Mass [kg] ([lb])
HC-UP352B	3.5	44 (6230)	85.1 (465)	26 (57.3)

[Unit: mm]

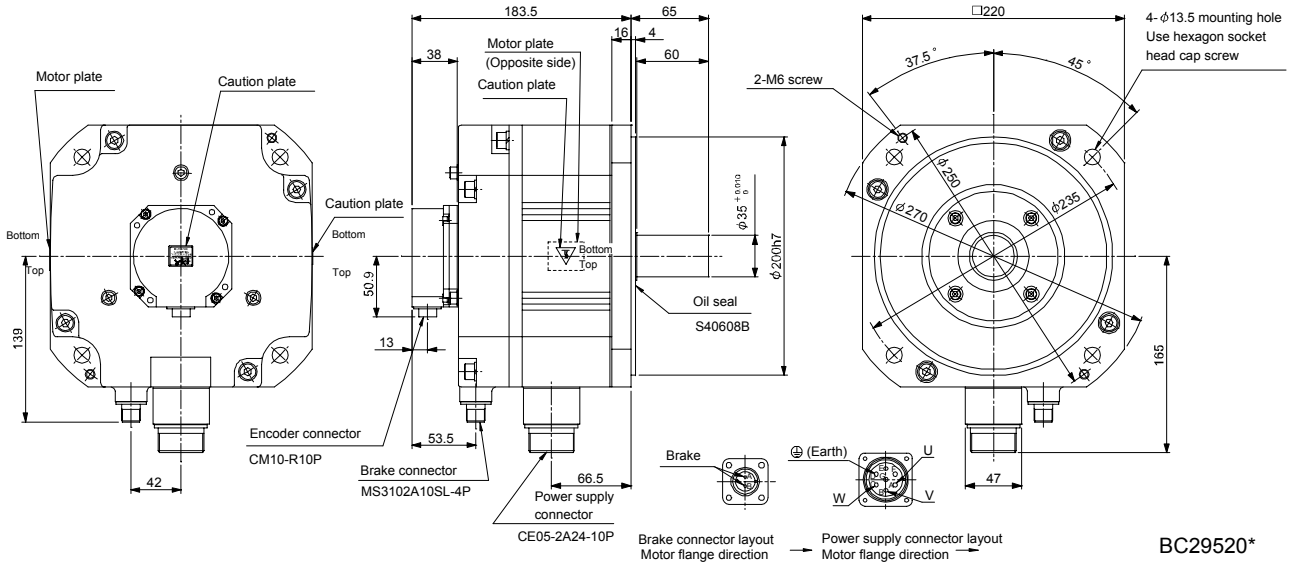

BC29520\*

Model	Output [kW]	Brake static friction torque [N · m] ([oz · in])	Inertia moment $J [ \times 10^{-4} \text{kg} \cdot \text{m}^2 ]$ ( $\text{WK}^2$ [oz · in <sup>2</sup> ])	Mass [kg] ([lb])
HC-UP502B	5.0	44 (6230)	124 (678)	30 (66.1)

[Unit: mm]

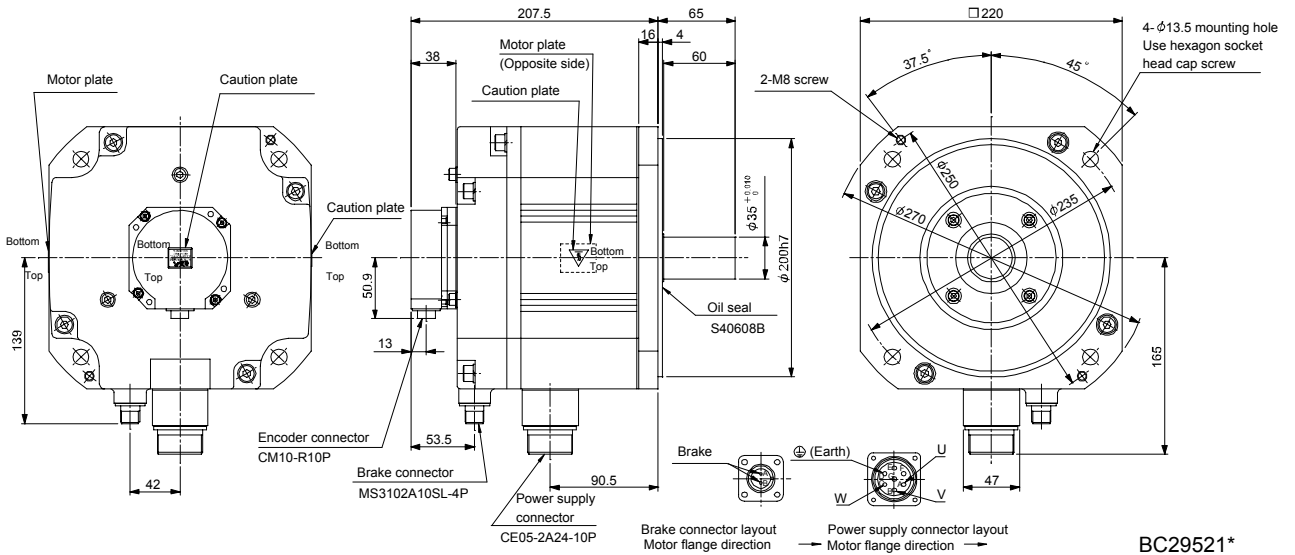

BC29521\*

## 10. HC-UP SERIES

---

### 10.7 Servo motor with oil seal

For the servo motor with oil seal, the oil seal prevents the entry of oil into the servo motor. Install the servo motor horizontally, and set the oil level in the gear box to be lower than the oil seal lip always.

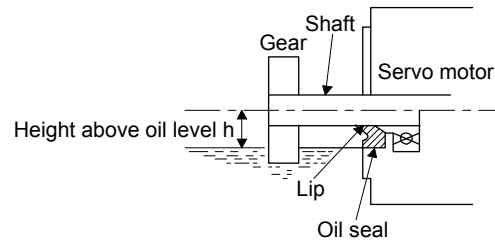

Servo motor	Height above oil level h [mm]
HC-UP72 · 152	20
HC-UP202 to 502	25

# 11. HC-LP SERIES

## 11. HC-LP SERIES

This chapter provides information on the servo motor specifications and characteristics. When using the HC-LP series servo motor, always read the Safety Instructions in the beginning of this manual and chapters 1 to 4, in addition to this chapter.

### 11.1 Model name make up

The following describes what each block of a model name indicates. Note that not all the combinations of the symbols exist.

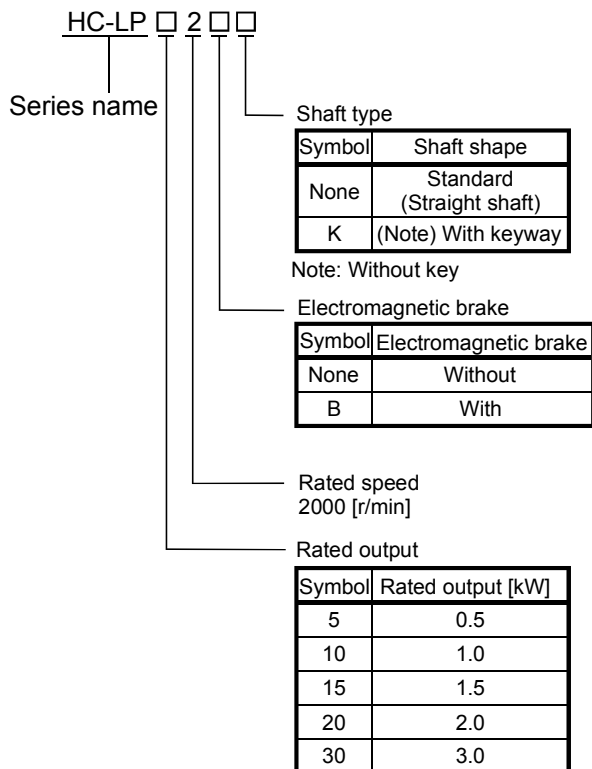

Appearance

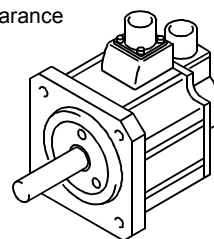

## 11. HC-LP SERIES

### 11.2 Standard specifications

#### 11.2.1 Standard specifications list

Item			Servo motor	HC-LP series (Low inertia · middle capacity)				
				52	102	152	202	302
Applicable servo amplifier/drive unit	MR-J3-□A/B/B-RJ006/T			60	100	200	350	500
Continuous running duty (Note 1)	Rated output	[kW]		0.5	1.0	1.5	2.0	3.0
	Rated torque	[N · m]		2.39	4.78	7.16	9.55	14.3
		[oz · in]		339	677	1010	1350	2030
Rated speed (Note 1)	[r/min]			2000				
Maximum speed	[r/min]			3000				
Instantaneous permissible speed	[r/min]			3450				
Maximum torque	[N · m]			7.16	14.4	21.6	28.5	42.9
	[oz · in]			1010	2040	3060	4040	6080
Power rate at continuous rated torque	[kW/s]			17.9	49.7	80.1	41.5	56.8
Inertia moment (Note 3)	J	[× 10 <sup>-4</sup> kg · m <sup>2</sup> ]		3.10	4.62	6.42	22.0	36.0
	WK <sup>2</sup>	[oz · in <sup>2</sup> ]		16.9	25.3	35.1	120	197
Recommended ratio of load inertia moment to servo motor shaft inertia moment (Note 2)				10 times or less				
Power supply capacity				Refer to "Power supply equipment capacity and generated loss of servo amplifiers" in Servo Amplifier Instruction Manual.				
Rated current	[A]			3.2	5.9	9.9	14	23
Maximum current	[A]			9.6	18	30	42	69
Speed/position detector				Encoder common to absolute position and incremental detection systems (Resolution per servo motor 1 rotation : 262144 pulse/rev)				
Accessory				Oil seal				
Insulation class				155(F)				
Structure				Totally-enclosed, natural-cooling (IP rating: IP65 (Note 4))				
Environmental conditions (Note 5)	Ambient temperature	Operation	[°C]	0 to 40 (non-freezing)				
			[°F]	32 to 104 (non-freezing)				
		Storage	[°C]	-15 to 70 (non-freezing)				
			[°F]	5 to 158 (non-freezing)				
	Ambient humidity	Operation		80%RH or less (non-condensing)				
		Storage		90%RH or less (non-condensing)				
	Ambience			Indoors (no direct sunlight) Free from corrosive gas, flammable gas, oil mist, dust and dirt.				
	Altitude			Max.1000m above sea level				
Vibration resistance (Note 6)	[m/s <sup>2</sup> ]			X: 9.8 Y: 24.5			X: 19.6 Y: 49	
Vibration rank (Note 7)				V10				
Permissible load for the shaft (Note 8)	L [mm]			55			79	
	Radial	[N]		980			2060	
		[lb]		220			463	
	Thrust	[N]		490			980	
		[lb]		110			220	
Mass (Note 3)	[kg]			6.5	8.0	10	21	28
	[lb]			14.3	17.6	22.0	46.3	61.7

# 11. HC-LP SERIES

Note 1. When the power supply voltage drops, we cannot guarantee the out put and rated speed.

2. If the load inertia moment ratio exceeds the indicated value, please consult your local sales office.
3. Refer to the outline dimension drawing for the servo motor with an electromagnetic brake.
4. Except for the shaft – through portion.
5. In the environment where the servo motor is exposed to oil mist, oil and/or water, the servo motor of the standard specifications may not be usable. Contact your local sales office.
6. The vibration direction is as shown in the figure. The value is the one at the part that indicates the maximum value (normally the opposite-to-load side bracket). When the servo motor stops, fretting is likely to occur at the bearing. Therefore, suppress the vibration to about half of the permissible value.

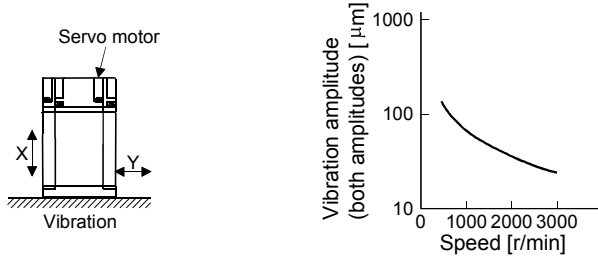

7. V10 indicates that the amplitude of a single servo motor is 10<sup>4</sup>μm or less. The following figure shows the servo motor installation position for measurement and the measuring position.

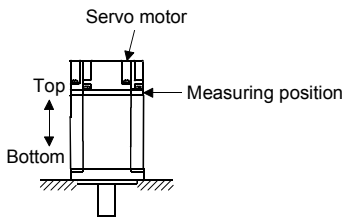

8. For the symbols in the table, refer to the following diagram: Do not subject the shaft to load greater than this value. The values in the table assume that the loads work singly.

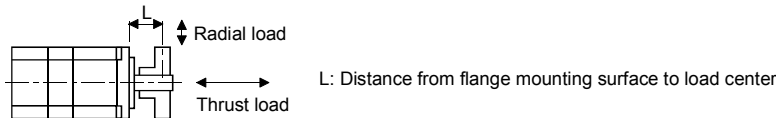

# 11. HC-LP SERIES

## 11.2.2 Torque characteristics

<b>POINT</b>
<ul style="list-style-type: none"> <li>For machines which produce unbalance torque, e.g. vertical lift applications, it is recommended to use the servo motor so that the unbalance torque will be within 70% of the rated torque.</li> </ul>

When the power input of the servo amplifier are 3-phase 200VAC or 1-phase 230VAC, the torque characteristic is indicated by the heavy line. For the 1-phase 200VAC power supply, part of the torque characteristic is indicated by the thin line. HC-LP52 supports 1-phase power supply input.

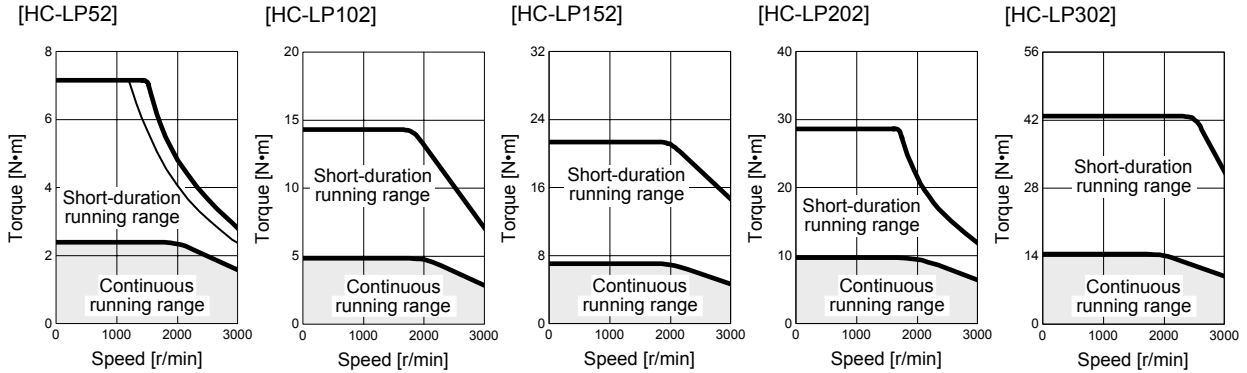

## 11. HC-LP SERIES

### 11.3 Electromagnetic brake



**CAUTION**

- The electromagnetic brake is provided to prevent a drop at a power failure or servo alarm occurrence during vertical drive or to hold a shaft at a stop. Do not use it for normal braking (including braking at servo lock).
- Before performing the operation, be sure to confirm that the electromagnetic brake operates properly.
- The operation time of the electromagnetic brake differs depending on the power supply circuit you use. Be sure to check the operation delay time with a real machine.

The characteristics of the electromagnetic brake provided for the servo motor with an electromagnetic brake are indicated below.

Item	Servo motor	HC-LP series	
		52B to 152B	202B * 302B
Type (Note 1)		Spring-loaded safety brake	
Rated voltage (Note 4)		24V <sup>0</sup> <sub>-10%</sub> DC	
Capacity	[W] at 20°C (68°F)	19	34
Coil resistance (Note 6)	[Ω]	29.0	17.0
Inductance (Note 6)	[H]	0.80	1.17
Brake static friction torque	[N · m]	8.5	44
	[oz · in]	1200	6230
Release delay time (Note 2)	[s]	0.04	0.1
Braking delay time (Note 2)	[s] DC off	0.03	0.03
Permissible braking work	Per braking [J]	400	4500
	Per hour [J]	4000	45000
Brake looseness at servo motor shaft (Note 5)	[degrees]	0.2 to 0.6	0.2 to 0.6
Brake life (Note 3)	Number of braking cycles [times]	20000	20000
	Work per braking [J]	200	1000
Selection example of surge absorbers to be used (Note 7, 8)	For the suppressed voltage 125V	TND20V-680KB	
	For the suppressed voltage 350V	TND10V-221KB	

Note 1. There is no manual release mechanism. When it is necessary to hand-turn the servo motor shaft for machine centering, etc., use a separate 24VDC power supply to release the brake electrically.

2. The value for initial ON gap at 20°C (68°F).

3. The brake gap will increase as the brake lining wears, but the gap is not adjustable. The brake life indicated is the number of braking cycles after which adjustment will be required.

4. Always prepare a power supply exclusively used for the electromagnetic brake.

5. The above values are typical initial values and not guaranteed values.

6. These values are measured values and not guaranteed values.

7. Select the electromagnetic brake control relay properly, considering the characteristics of the electromagnetic brake and surge absorber.

8. Manufactured by Nippon Chemi-Con Corporation.



## 11. HC-LP SERIES

### 11.4 Servo motors with special shafts

The servo motors with special shafts indicated by the symbol (K) in the table is available. K is the symbols attached to the servo motor model names.

Servo motor	Shaft shape
	Keyway shaft (without key)
HC-LP	K

Servo motor	Variable dimensions							
	S	R	Q	W	QK	QL	U	r
HC-LP52(B)K to 152(B)K	24h6	55	50	$8_{-0.036}^0$	36	5	$4_{+0.2}^0$	4
HC-LP202(B)K * 302(B)K	$35_{+0.010}^0$	79	75	$10_{-0.036}^0$	55	5	$5_{+0.2}^0$	5

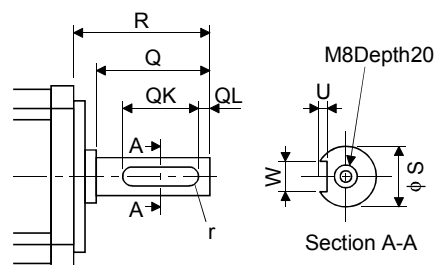

### 11.5 Wiring option

Connector sets to use in power supply connector or brake connector are available as option.

For details of each connector set, cable and connector set to use in wiring to encoder, refer to the Servo Amplifier Instruction Manual for using.

Make sure to use the following power supply connector set for conforming to the IEC/EN compliant.

Servo motor	Power supply connector set	Brake connector set
HC-LP52 to 152	MR-PWCNS1 Configuration products Plug: CE05-6A22-23SD-D-BSS Cable clamp: CE3057-12A-2-D (DDK)	Shared with the one for power supply (Note)
HC-LP202 * 302	MR-PWCNS2 Configuration products Plug: CE05-6A24-10SD-D-BSS Cable clamp: CE3057-16A-2-D (DDK)	MR-BKCN Configuration products Plug: D/MS3106A10SL-4S (D190) (DDK) Connector for cable: YSO10-5 to 8 (Daiwa Dengyo)

Note. Brake connector is not required since the power supply connector has a pin assigned for electromagnetic brake.

# 11. HC-LP SERIES

## 11.6 Outline dimension drawings

The dimensions without tolerances are reference dimensions.

Inertia moment on the table is the value calculated by converting the total value of inertia moment for servo motor, electromagnetic brake and decelerator with servo motor shaft.

### 11.6.1 Standard (without an electromagnetic brake)

Model	Output [kW]	Inertia moment J [ $\times 10^{-4}$ kg · m <sup>2</sup> ] (WK <sup>2</sup> [oz · in <sup>2</sup> ])	Mass [kg] (lb)
HC-LP52	0.5	3.10 (16.9)	6.5 (14.3)

[Unit: mm]

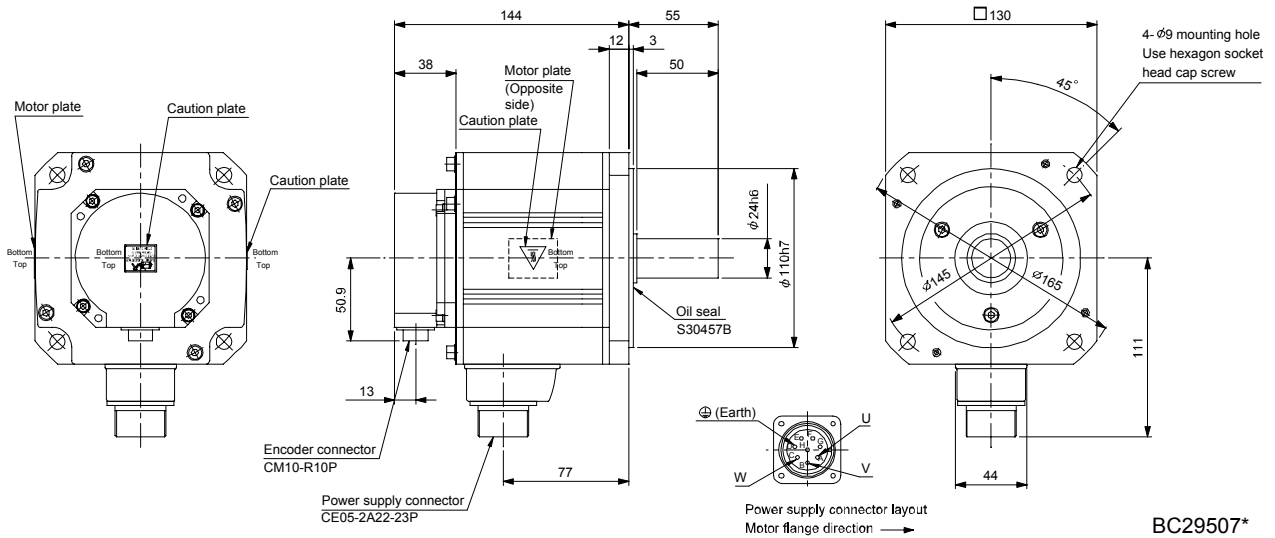

BC29507\*

Model	Output [kW]	Inertia moment J [ $\times 10^{-4}$ kg · m <sup>2</sup> ] (WK <sup>2</sup> [oz · in <sup>2</sup> ])	Mass [kg] (lb)
HC-LP102	1.0	4.62(25.3)	8.0 (17.6)

[Unit: mm]

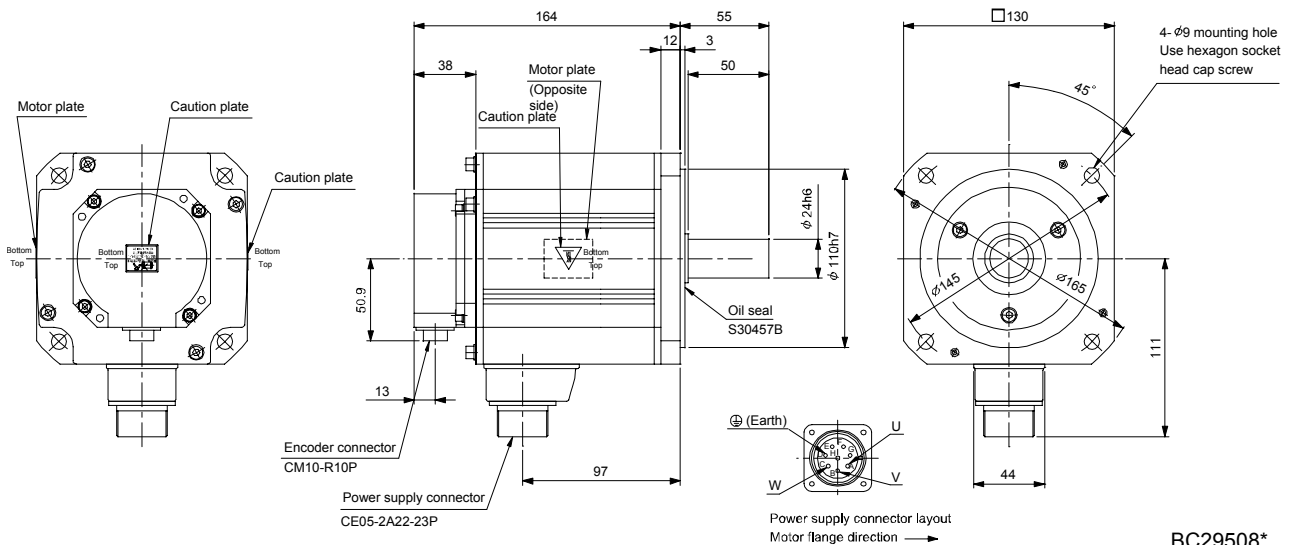

BC29508\*

# 11. HC-LP SERIES

Model	Output [kW]	Inertia moment J [ $\times 10^{-4}$ kg · m <sup>2</sup> ] (WK <sup>2</sup> [oz · in <sup>2</sup> ])	Mass [kg] (lb)
HC-LP152	1.5	6.42(35.1)	10 (22.0)

[Unit: mm]

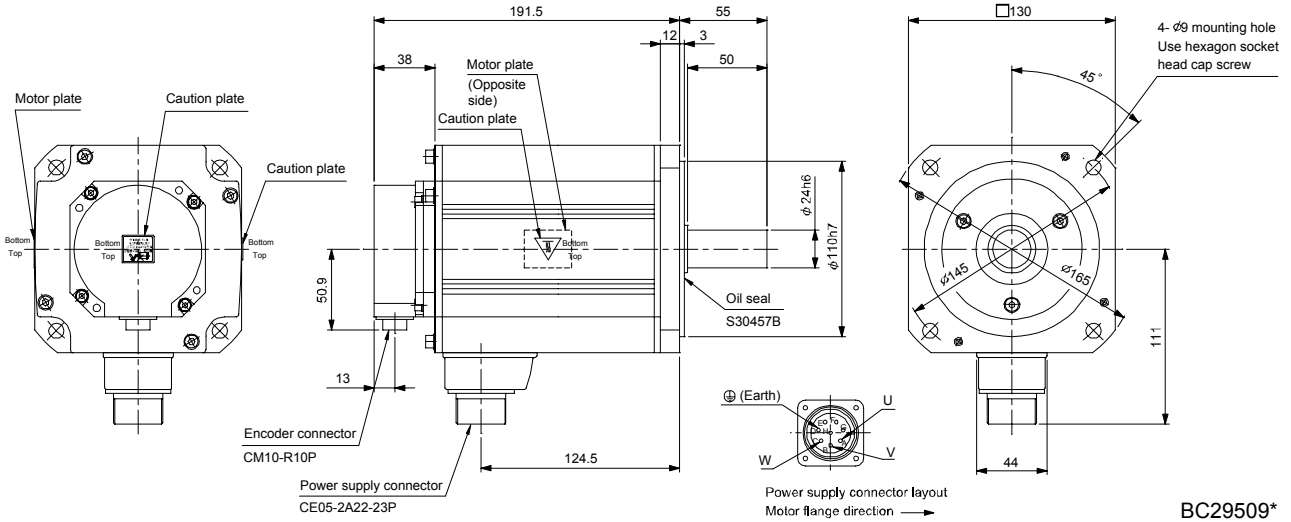

BC29509\*

Model	Output [kW]	Inertia moment J [ $\times 10^{-4}$ kg · m <sup>2</sup> ] (WK <sup>2</sup> [oz · in <sup>2</sup> ])	Mass [kg] (lb)
HC-LP202	2.0	22.0(120)	21 (46.3)

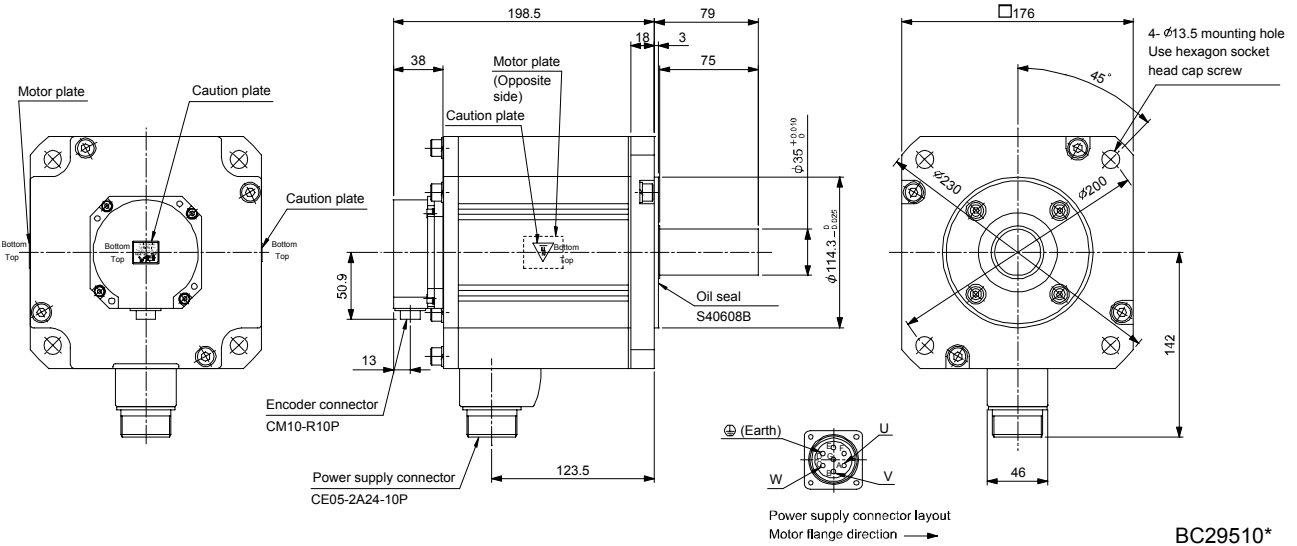

BC29510\*

# 11. HC-LP SERIES

Model	Output [kW]	Inertia moment J [ $\times 10^{-4}$ kg · m <sup>2</sup> ] (WK <sup>2</sup> [oz · in <sup>2</sup> ])	Mass [kg] (lb)
HC-LP302	3.0	36.0(197)	28 (61.7)

[Unit: mm]

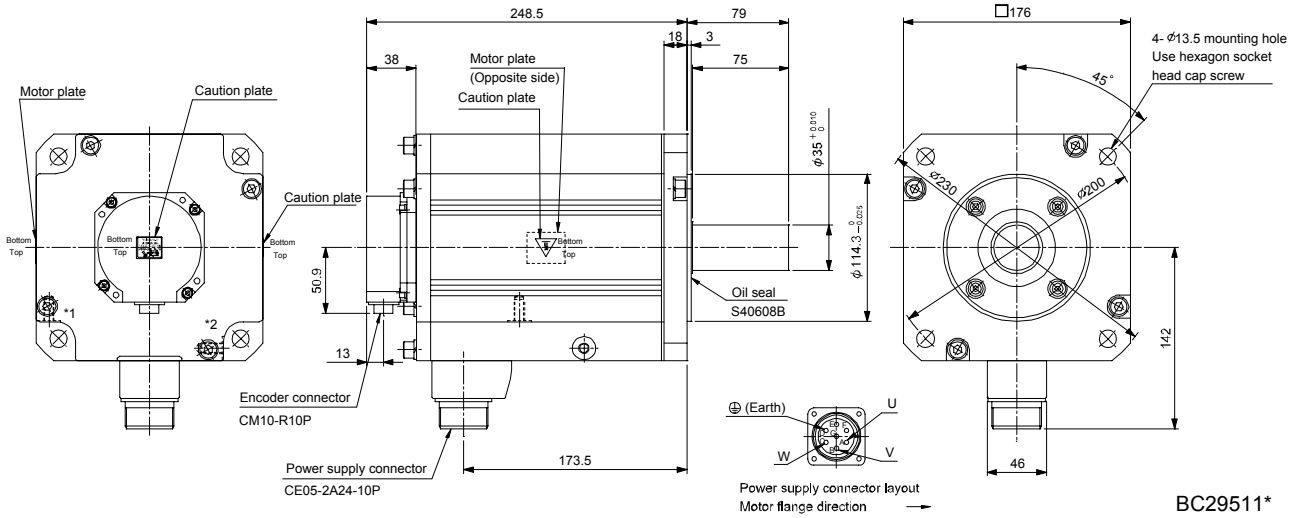

## 11.6.2 With an electromagnetic brake

Model	Output [kW]	Brake static friction torque [N · m] (oz · in)	Inertia moment J [ $\times 10^{-4}$ kg · m <sup>2</sup> ] (WK <sup>2</sup> [oz · in <sup>2</sup> ])	Mass [kg] (lb)
HC-LP52B	0.5	8.5 (1200)	5.20 (28.4)	9.0 (19.8)

[Unit: mm]

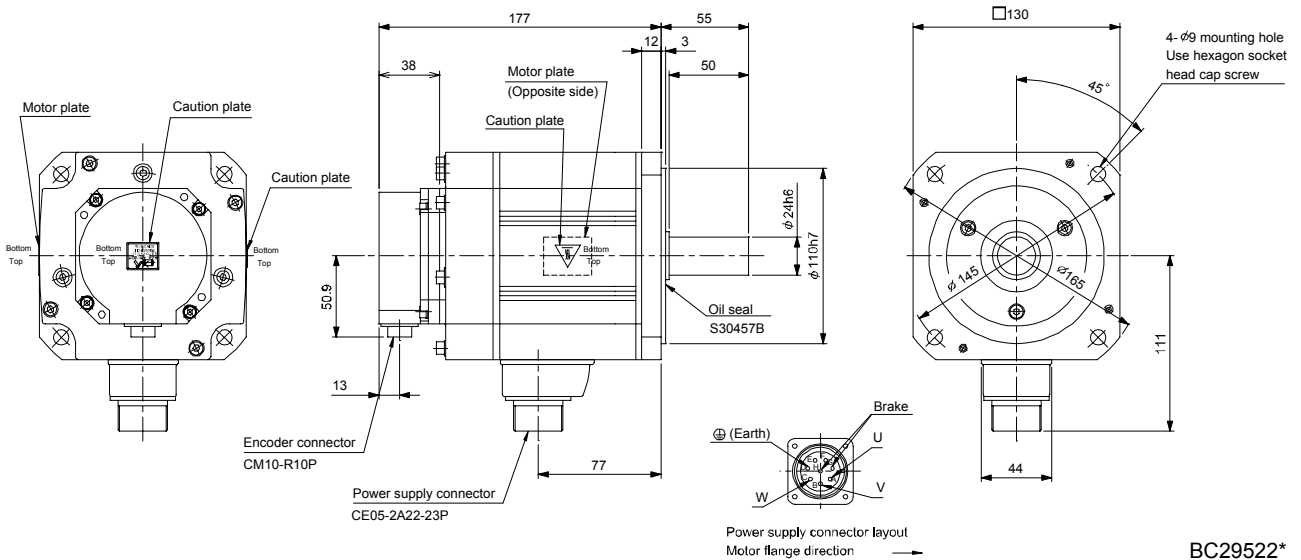

# 11. HC-LP SERIES

Model	Output [kW]	Brake static friction torque [N · m] (oz · in)	Inertia moment J [ $\times 10^{-4}$ kg · m <sup>2</sup> ] (WK <sup>2</sup> [oz · in <sup>2</sup> ])	Mass [kg] (lb)
HC-LP102B	1.0	8.5 (1200)	6.72 (36.7)	11 (24.3)

[Unit: mm]

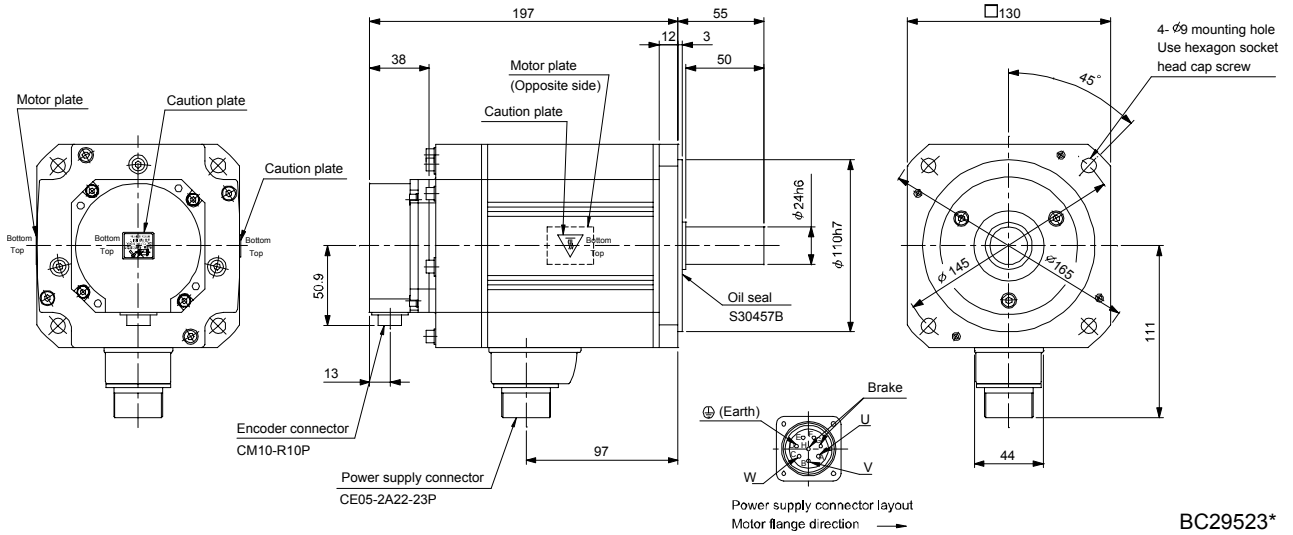

Model	Output [kW]	Brake static friction torque [N · m] (oz · in)	Inertia moment J [ $\times 10^{-4}$ kg · m <sup>2</sup> ] (WK <sup>2</sup> [oz · in <sup>2</sup> ])	Mass [kg] (lb)
HC-LP152B	1.5	8.5 (1200)	8.52 (46.6)	13 (28.7)

[Unit: mm]

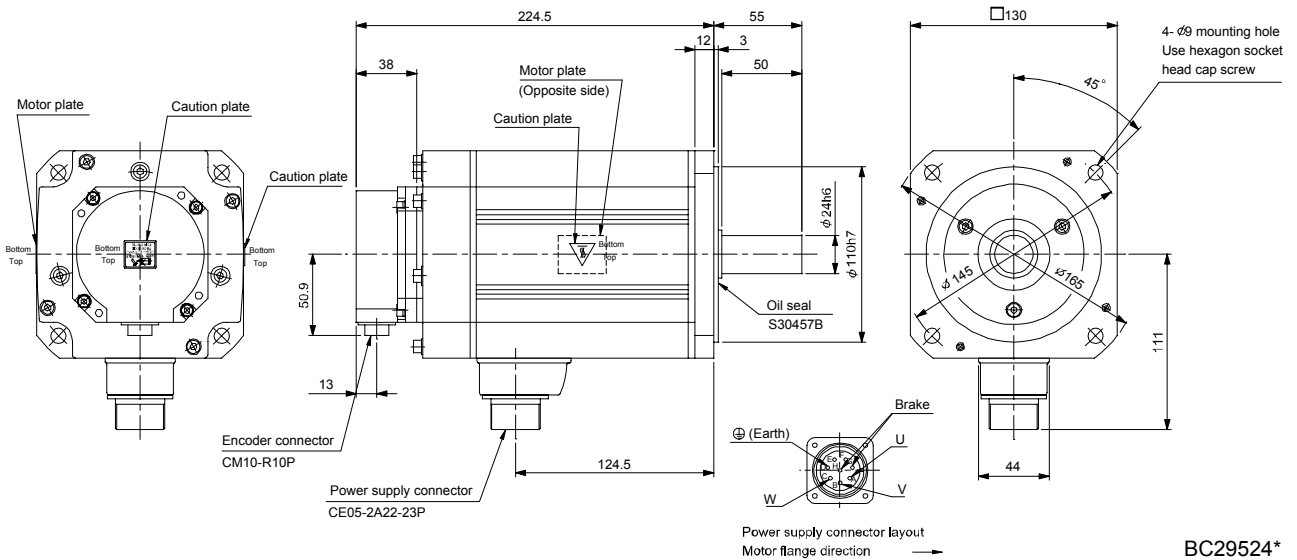

# 11. HC-LP SERIES

Model	Output [kW]	Brake static friction torque [N · m] (oz · in)	Inertia moment $J [ \times 10^{-4} \text{kg} \cdot \text{m}^2 ]$ ( $\text{WK}^2 [\text{oz} \cdot \text{in}^2]$ )	Mass [kg] (lb)
HC-LP202B	2.0	44 (6230)	32.0 (175)	27 (59.5)

[Unit: mm]

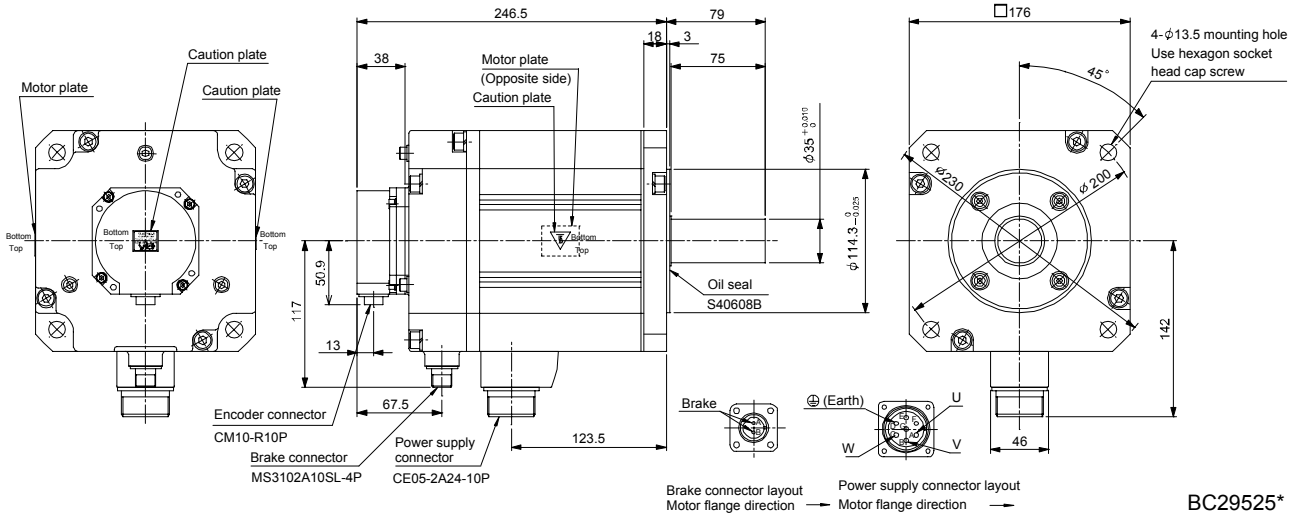

BC29525\*

Model	Output [kW]	Brake static friction torque [N · m] (oz · in)	Inertia moment $J [ \times 10^{-4} \text{kg} \cdot \text{m}^2 ]$ ( $\text{WK}^2 [\text{oz} \cdot \text{in}^2]$ )	Mass [kg] (lb)
HC-LP302B	3.0	44 (6230)	46.0 (252)	34 (75.0)

[Unit: mm]

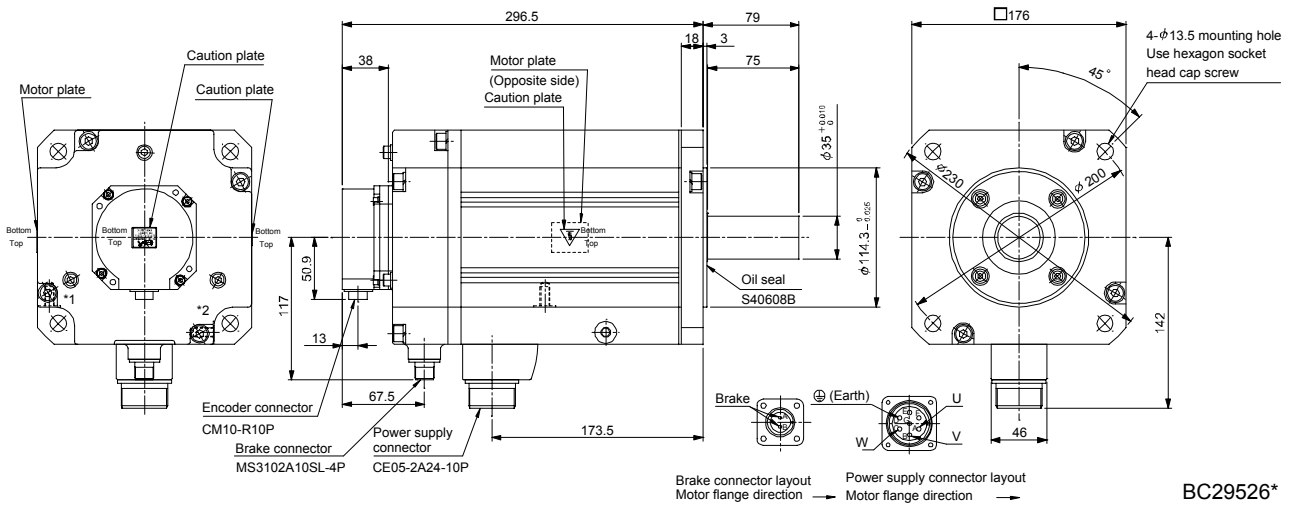

BC29526\*

## 11. HC-LP SERIES

---

### 11.7 Servo motor with oil seal

For the servo motor with oil seal, the oil seal prevents the entry of oil into the servo motor. Install the servo motor horizontally, and set the oil level in the gear box to be lower than the oil seal lip always.

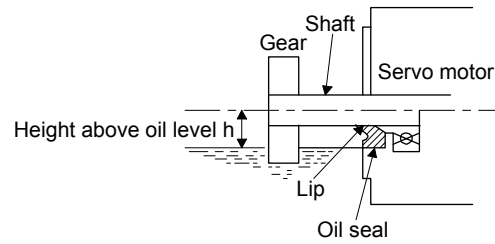

Servo motor	Height above oil level h [mm]
HC-LP52 to 152	20
HC-LP202 · 302	25

# 12. HF-JP SERIES

## 12. HF-JP SERIES

This chapter provides information on the servo motor specifications and characteristics. When using the HF-JP series servo motor, always read the Safety Instructions in the beginning of this manual and chapters 1 to 4, in addition to this chapter.

### 12.1 Model name make up

The following describes what each block of a model name indicates. Note that not all the combinations of the symbols exist.

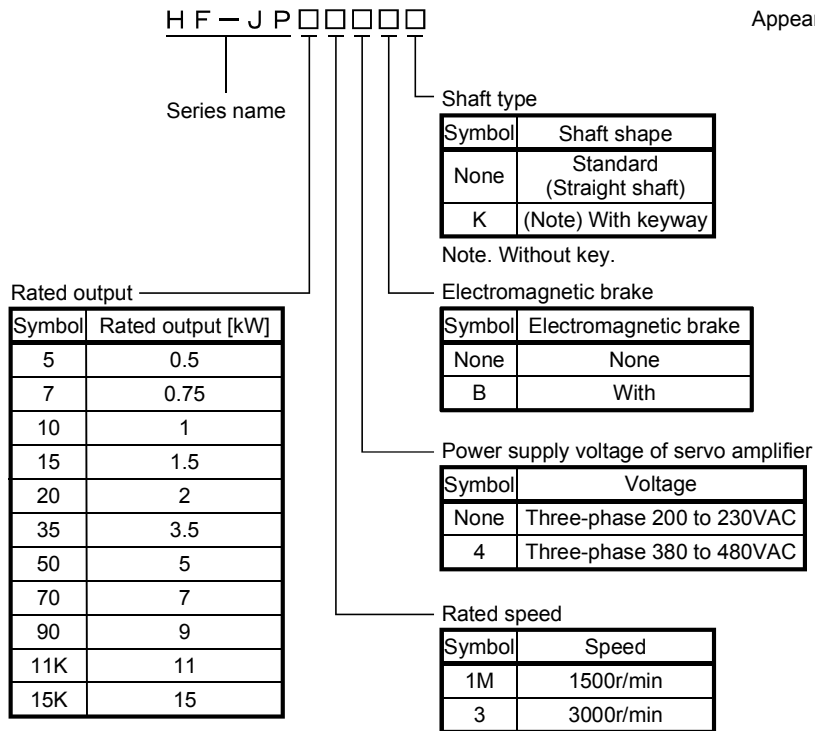



## 12. HF-JP SERIES

### 12.2 Standard specifications

#### 12.2.1 Standard specifications list

Item		Servo motor		HF-JP 3000r/min series (200VAC-compatible, low inertia · medium capacity)							
		53	73	103	153	203	353	503	703	903	
Applicable servo amplifier/drive unit	MR-J3-□A/B/B-RJ006/T	60	70	100	200		350	500	700	11K	
Continuous running duty (Note 1)	Rated output (Note 9) [kW]	0.5	0.75	1.0	1.5	2.0	3.3 (3.5)	5.0	7.0	9.0	
	Rated torque (Note 9)	[N · m]	1.59	2.39	3.18	4.77	6.37	10.5 (11.1)	15.9	22.3	28.6
		[oz · in]	225	33	450	675	907	1490 (1570)	2250	3160	4050
Rated speed (Note 1)	[r/min]	3000									
Maximum speed	[r/min]	6000							5000		
Instantaneous permissible speed	[r/min]	6900							5750		
Maximum torque (Note 9)	[N · m]	4.77 (6.37)	7.16 (9.55)	9.55 (12.7)	14.3 (19.1)	19.1 (25.5)	32.0 (44.6)	47.7 (63.7)	66.8	85.8	
	[oz · in]	675 (902)	1010 (1350)	1350 (1800)	2030 (2700)	2700 (3610)	4530 (6320)	6750 (9020)	9460	12200	
Power rate at continuous rated torque	[kW/s]	16.7	27.3	38.2	60.2	82.4	83.5	133	114.6	147.1	
Inertia moment (Note 3)	J [ $\times 10^{-4}$ kg · m <sup>2</sup> ]	1.52	2.09	2.65	3.79	4.92	13.2	19.0	43.3	55.8	
	WK [oz · in <sup>2</sup> ]	8.31	11.4	14.5	20.7	26.9	72.2	104	237	305	
Recommended ratio of load inertia moment to servo motor shaft inertia moment (Note 2)		10 times or less									
Power supply capacity		Refer to "Power supply equipment capacity and generated loss of servo amplifiers" in Servo Amplifier Instruction Manual.									
Rated current (Note 9)	[A]	3.0	5.6	5.6	10.6	10.6	16.6 (17.6)	27	34	41	
Maximum current (Note 9)	[A]	9.0(12)	17(23)	17(23)	32(43)	32(43)	51(71)	81(108)	103	134	
Speed/position detector		Encoder common to absolute position and incremental detection systems (Resolution per servo motor 1 rotation: 262144pulse/rev)									
Accessory		Oil seal									
Insulation class		155(F)									
Structure		Totally – enclosed, natural-cooling (IP rating: IP67 (Note 4))									
Environmental conditions (Note 5)	Ambient temperature	Operation	[°C]	0 to 40 (non-freezing)							
			[°F]	32 to 104 (non-freezing)							
		Storage	[°C]	–15 to 70 (non-freezing)							
			[°F]	5 to 158 (non-freezing)							
	Ambient humidity	Operation	80%RH or less (non-condensing)								
		Storage	90%RH or less (non-condensing)								
	Ambience	Indoors (no direct sunlight) Free from corrosive gas, flammable gas, oil mist, dust and dirt.									
	Altitude	Max.1000m above sea level									
Vibration resistance (Note 6)	[m/s <sup>2</sup> ]	X, Y: 24.5							X: 24.5m/s <sup>2</sup> Y: 29.4m/s <sup>2</sup>		
Vibration rank (Note 7)		V10									
Permissible load for the shaft (Note 8)	L	[mm]	40				55		79		
		Radial	[N]	323				980		2450	
	[lb]		72.6				220		551		
	Thrust	[N]	284				490		980		
[lb]		63.8				110		220			
Mass (Note 3)	[kg]	3.0	3.7	4.5	5.9	7.5	13	18	29	36	
	[lb]	6.61	8.16	9.92	13.0	16.5	28.7	39.7	63.9	79.4	

## 12. HF-JP SERIES

Servo motor			HF-JP 3000r/min series (400VAC-compatible, low inertia • medium capacity)									
			534	734	1034	1534	2034	3534	5034	7034	9034	
Applicable servo amplifier/drive unit	MR-J3-□A4/B4/B4-RJ006/T4		60	100			200		350	500	700	11K
Continuous running duty (Note 1)	Rated output (Note 9)	[kW]	0.5	0.75	1.0	1.5	2.0	3.3 (3.5)	5.0	7.0	9.0	
	Rated torque (Note 9)	[N • m]	1.59	2.39	3.18	4.77	6.37	10.5 (11.1)	15.9	22.3	28.6	
		[oz • in]	225	338	450	675	902	1490 (1570)	2250	3160	4050	
Rated speed (Note 1)	[r/min]		3000									
Maximum speed	[r/min]		6000						5000			
Instantaneous permissible speed	[r/min]		6900						5750			
Maximum torque (Note 9)	[N • m]		4.77 (6.37)	7.16 (9.55)	9.55 (12.7)	14.3 (19.1)	19.1 (25.5)	32.0 (44.6)	47.7 (63.7)	66.8	85.8	
		[oz • in]	675 (902)	1010 (1350)	1350 (1800)	2030 (2700)	2700 (3610)	4530 (6320)	6750 (9020)	9460	12200	
Power rate at continuous rated torque	[kW/s]		16.7	27.3	38.2	60.2	82.4	83.5	133	114.6	147.1	
Inertia moment (Note 3)	J	[ $\times 10^{-4}$ kg • m <sup>2</sup> ]	1.52	2.09	2.65	3.79	4.92	13.2	19.0	43.3	55.8	
	WK	[oz • in <sup>2</sup> ]	8.31	11.4	14.5	20.7	26.9	72.2	104	237	305	
Recommended ratio of load inertia moment to servo motor shaft inertia moment (Note 2)	10 times or less											
Power supply capacity	Refer to "Power supply equipment capacity and generated loss of servo amplifiers" in Servo Amplifier Instruction Manual.											
Rated current (Note 9)	[A]		1.5	2.8	2.8	5.4	5.4	8.3(8.8)	14	17	21	
Maximum current (Note 9)	[A]		4.5(6.0)	8.4(12)	8.4(12)	17(22)	17(22)	26(36)	41(54)	52	67	
Speed/position detector	Encoder common to absolute position and incremental detection systems (Resolution per servo motor 1 rotation: 262144pulse/rev)											
Accessory	Oil seal											
Insulation class	155(F)											
Structure	Totally – enclosed, natural-cooling (IP rating: IP67 (Note 4))											
Environmental conditions (Note 5)	Ambient temperature	Operation	[°C]	0 to 40 (non-freezing)								
			[°F]	32 to 104 (non-freezing)								
		Storage	[°C]	–15 to 70 (non-freezing)								
			[°F]	5 to 158 (non-freezing)								
	Ambient humidity	Operation	80%RH or less (non-condensing)									
		Storage	90%RH or less (non-condensing)									
	Ambience	Indoors (no direct sunlight) Free from corrosive gas, flammable gas, oil mist, dust and dirt.										
	Altitude	Max.1000m above sea level										
Vibration resistance (Note 6)	[m/s <sup>2</sup> ]		X, Y: 24.5						X: 24.5m/s <sup>2</sup> Y: 29.4m/s <sup>2</sup>			
Vibration rank (Note 7)	V10											
Permissible load for the shaft (Note 8)	L	[mm]		40			55		79			
		Radial	[N]	323			980		2450			
	[lb]		72.6			220		551				
	Thrust	[N]	284			490		980				
[lb]		63.8			110		220					
Mass (Note 3)	[kg]		3.0	3.7	4.5	5.9	7.5	13	18	29	36	
	[lb]		6.61	8.16	9.92	13.0	16.5	28.7	39.7	64	79	

## 12. HF-JP SERIES

Item		Servo motor		HF-JP 1500r/min series (200VAC-compatible, low inertia · large capacity)		HF-JP 1500r/min series (400VAC-compatible, low inertia · large capacity)	
				11K1M	15K1M	11K1M4	15K1M4
Applicable servo amplifier/drive unit	(Note 10) MR-J3-□A(4)-LR/ B(4)-LR/T(4)-LR			11K	15K	11K	15K
Continuous running duty (Note 1)	Rated output	[kW]	11	15	11	15	
	Rated torque	[N · m]	70	95.5	70	95.5	
		[oz · in]	9910	13520	6610	13520	
Rated speed (Note 1)	[r/min]	1500					
Maximum speed	[r/min]	3000					
Instantaneous permissible speed	[r/min]	3450					
Maximum torque	[N · m]	210	286	210	286		
	[oz · in]	29700	40500	29700	40500		
Power rate at continuous rated torque	[kW/s]	223	290	223	290		
Inertia moment (Note 3)	J	[ $\times 10^{-4}$ kg · m <sup>2</sup> ]	220	315	220	315	
	WK	[oz · in <sup>2</sup> ]	1200	1720	1200	1720	
Recommended ratio of load inertia moment to servo motor shaft inertia moment (Note 2)	10 times or less						
Power supply capacity	Refer to "Power supply equipment capacity and generated loss of servo amplifiers" in Servo Amplifier Instruction Manual.						
Rated current	[A]	60	76	32	38		
Maximum current	[A]	200	315	220	315		
Speed/position detector	Encoder common to absolute position and incremental detection systems (Resolution per servo motor 1 rotation: 262144pulse/rev)						
Accessory	Oil seal						
Insulation class	155(F)						
Structure	Totally - enclosed, natural-cooling (IP rating: IP67 (Note 4))						
Environmental conditions (Note 5)	Ambient temperature	Operation	[°C]	0 to 40 (non-freezing)			
			[°F]	32 to 104 (non-freezing)			
		Storage	[°C]	-15 to 70 (non-freezing)			
			[°F]	5 to 158 (non-freezing)			
	Ambient humidity	Operation	80%RH or less (non-condensing)				
		Storage	90%RH or less (non-condensing)				
	Ambience	Indoors (no direct sunlight) Free from corrosive gas, flammable gas, oil mist, dust and dirt.					
	Altitude	Max.1000m above sea level					
Vibration resistance (Note 6)	[m/s <sup>2</sup> ]	X, Y: 24.5					
Vibration rank (Note 7)	V10						
Permissible load for the shaft (Note 8)	L	[mm]	110				
		Radial	[N]	2940			
	[lb]		661				
	Thrust	[N]	980				
		[lb]	220				
Mass (Note 3)	[kg]	62	86	62	86		
	[lb]	137	190	137	190		

## 12. HF-JP SERIES

Note 1. When the power supply voltage drops, the output and the rated speed cannot be guaranteed.

2. If the load inertia moment ratio exceeds the indicated value, please consult your local sales office.
3. Refer to the outline dimension drawing for the servo motor with an electromagnetic brake.
4. Except for the shaft-through portion.
5. In the environment where the servo motor is exposed to oil mist, oil and/or water, the servo motor of the standard specifications may not be usable. Please contact your local sales office.
6. The vibration direction is as shown in the figure. The value is the one at the part that indicates the maximum value (normally the opposite-to-load side bracket). When the servo motor stops, fretting is likely to occur at the bearing. Therefore, suppress the vibration to about half of the permissible value.

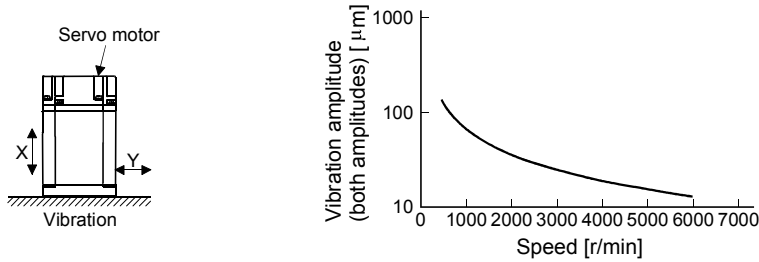

7. V10 indicates that the amplitude of a single servo motor is 10 $\mu\text{m}$  or less. The following figure shows the servo motor installation position for measurement and the measuring position.

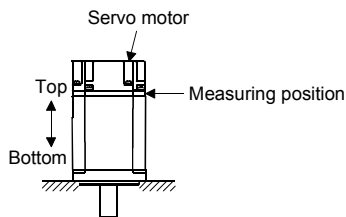

8. For the symbols in the table, refer to the following diagram: Do not subject the shaft to load greater than this value. The values in the table assume that the loads work singly.

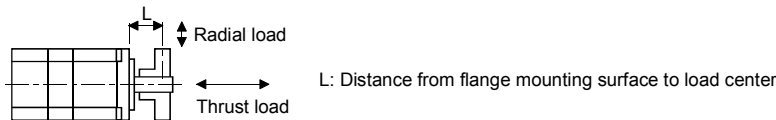

9. Values in ( ) are applicable when the maximum torque is increased to 400%. The maximum torque can be increased to 400% by combining with the following servo amplifiers.

MR-J3-□A(4)-U1□□

MR-J3-□B(4)-U1□□

MR-J3-□T(4)-U1□□

10. Contact your local sales office for fully closed loop control compatible servo amplifier.

## 12. HF-JP SERIES

### 12.2.2 Torque characteristics

POINT
<ul style="list-style-type: none"> <li>For machines which produce unbalance torque, e.g. vertical lift applications, it is recommended to use the servo motor so that the unbalance torque will be within 70% of the rated torque.</li> </ul>

#### (1) 3-phase 200VAC

When the power input of the servo amplifier are 3-phase 200VAC or 1-phase 230VAC, the torque characteristic is indicated by the heavy line. For the 1-phase 200VAC power supply, part of the torque characteristic is indicated by the thin line. HF-JP53 and HF-JP73 support 1-phase power supply input.

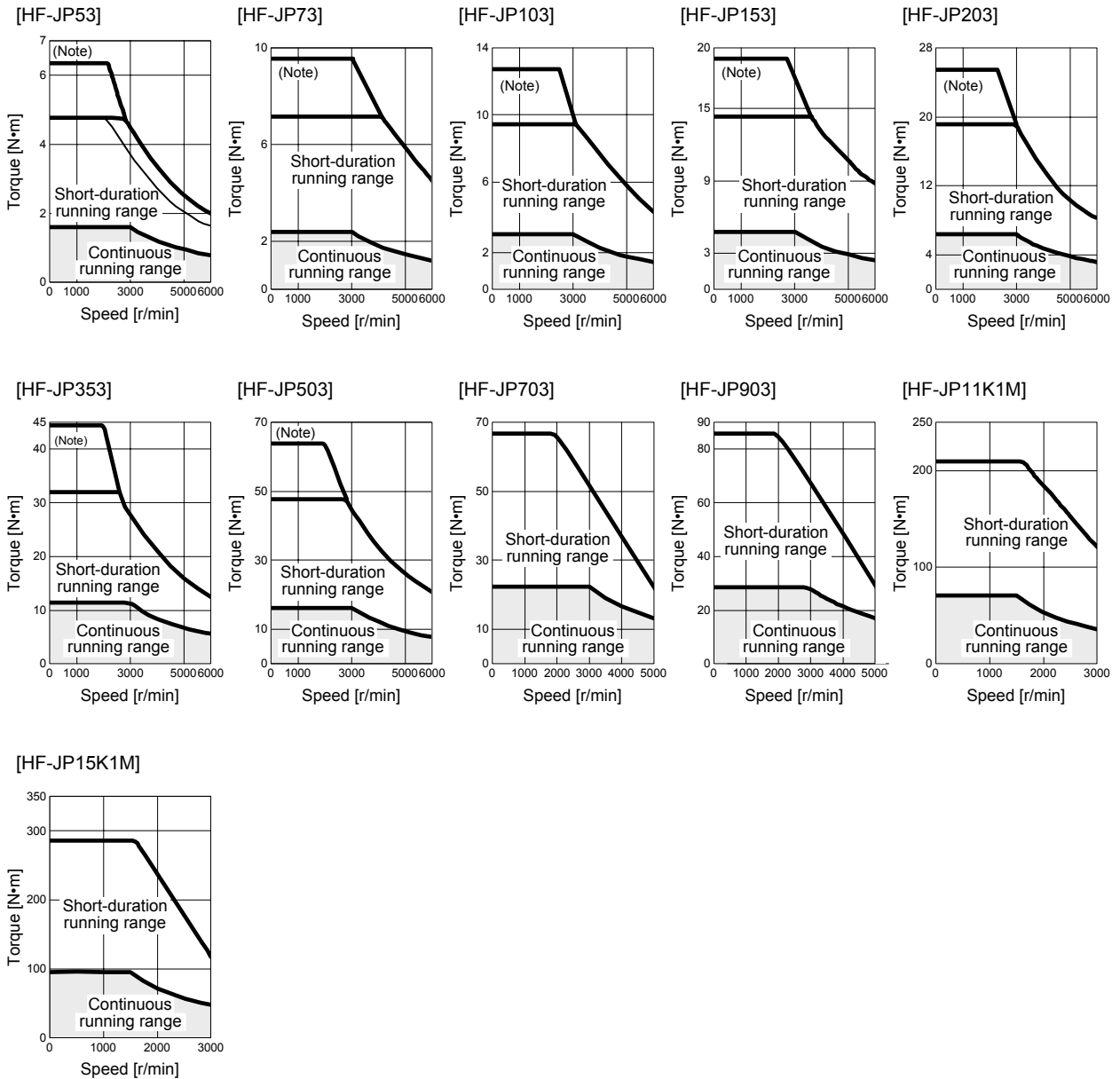

Note. Value at the maximum torque 400%.

## 12. HF-JP SERIES

### (2) 3-phase 400VAC

When the power input of the servo amplifier are 3-phase 400VAC, the torque characteristic is indicated by the heavy line. For the 3-phase 380VAC power supply, part of the torque characteristic is indicated by the thin line.

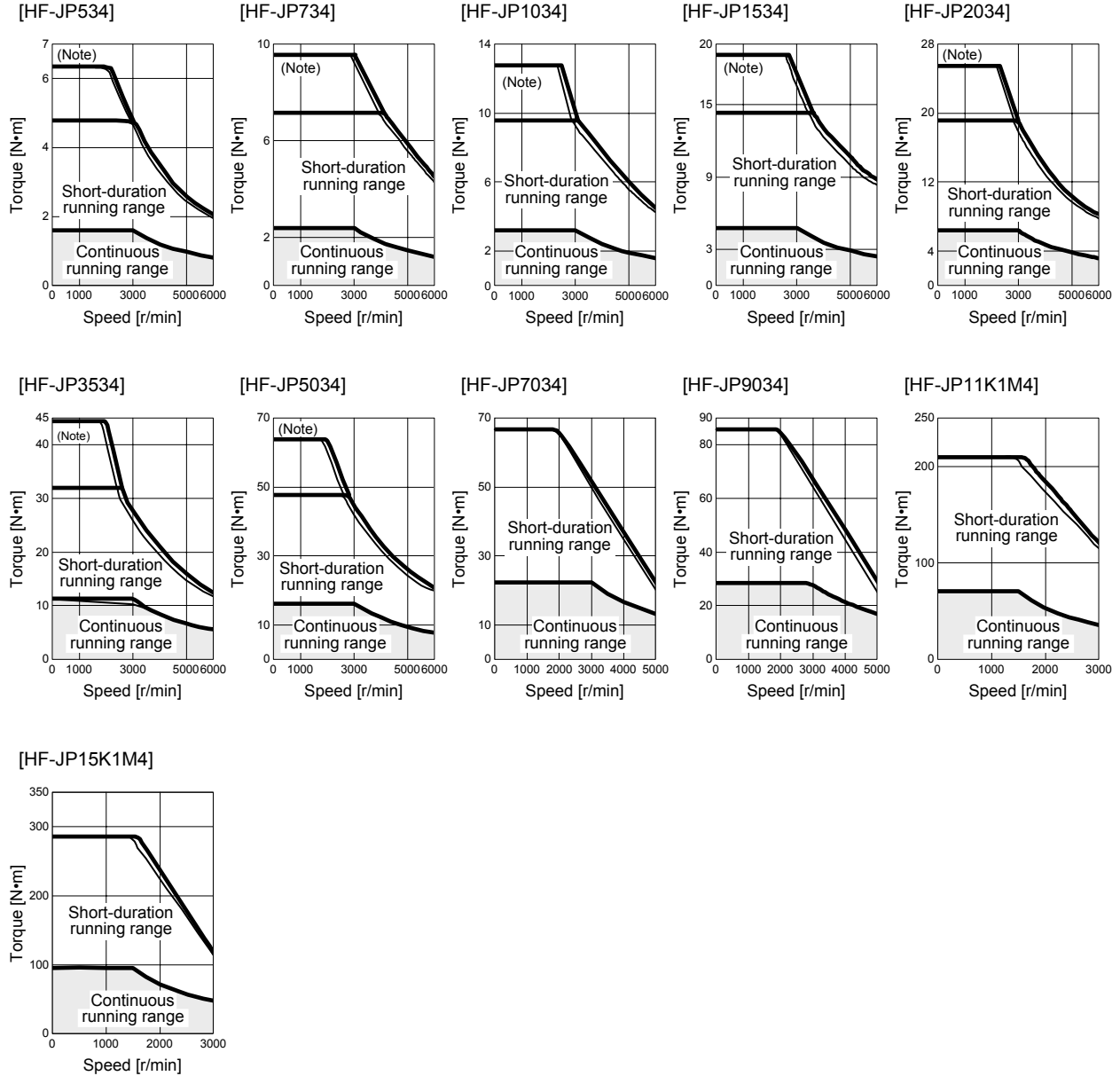

Note. Value at the maximum torque 400%.

## 12. HF-JP SERIES

### 12.3 Electromagnetic brake



**CAUTION**

- The electromagnetic brake is provided to prevent a drop at a power failure or servo alarm occurrence during vertical drive or to hold a shaft at a stop. Do not use it for normal braking (including braking at servo lock).
- Before performing the operation, be sure to confirm that the electromagnetic brake operates properly.
- The operation time of the electromagnetic brake differs depending on the power supply circuit you use. Be sure to check the operation delay time with a real machine.

The characteristics of the electromagnetic brake provided for the servo motor with an electromagnetic brake are indicated below.

Item	Servo motor	HF-JP series				
		53(4)B to 203(4)B	353(4)B · 503(4)B	11K1M(4)B · 15K1M(4)B	703(4)B · 903(4)	
Type (Note 1)		Spring-loaded safety brake				
Rated voltage (Note 4)		24VDC <sup>0</sup> <sub>-10%</sub>				
Capacity	[W] at 20°C (68°F)	11.7	23	32	34	
Coil resistance (Note 6)	[Ω]	49	25	18.2	16.8	
Inductance (Note 6)	[H]	0.37	0.25	0.73	1.10	
Brake static friction torque	[N · m]	6.6	16	127	44	
	[oz · in]	935	2266	17985	6230	
Release delay time (Note 2)	[s]	0.09	0.12	0.5	0.1	
Braking delay time (Note 2)	[s] DC off	0.03	0.03	0.2	0.03	
	Per braking	[J]	64	400	5000	4500
Permissible braking work	Per hour	[J]	640	4000	45200	45000
Brake looseness at servo motor shaft (Note 5)	[degrees]	0.01 to 0.8	0.01 to 0.6	0.01 to 0.6	0.2 to 0.6	
Brake life (Note 3)	Number of braking cycles	[times]	5000	5000	20000	20000
	Work per braking	[J]	64	400	400	1000
Selection example of surge absorbers to be used (Note 7)	For the suppressed voltage 125V		(Note 9) ERZV10D221		(Note 8) TND20V-680KB	
	For the suppressed voltage 350V		(Note 8) TNR-10V221K		(Note 8) TND10V-221KB	

Note 1. There is no manual release mechanism. When it is necessary to hand-turn the servo motor shaft for machine centering, etc., use a separate 24VDC power supply to release the brake electrically.

2. The value for initial ON gap at 20°C (68°F).

3. The brake gap will increase as the brake lining wears, but the gap is not adjustable. The brake life indicated is the number of braking cycles after which adjustment will be required.

4. Always prepare a power supply exclusively used for the electromagnetic brake.

5. The above values are typical initial values and not guaranteed values.

6. These values are measured values and not guaranteed values.

7. Select the electromagnetic brake control relay properly, considering the characteristics of the electromagnetic brake and surge absorber.

8. Manufactured by Nippon Chemi-Con Corporation.

9. Panasonic Corporation.

## 12. HF-JP SERIES

### 12.4 Servo motors with special shafts

The servo motors with special shafts indicated by the symbol (K) in the table is available. K is the symbols attached to the servo motor model names.

Servo motor	Shaft shape
	Keyway shaft (without key)
HF-JP53(4)□ to 15K1M(4)□	K

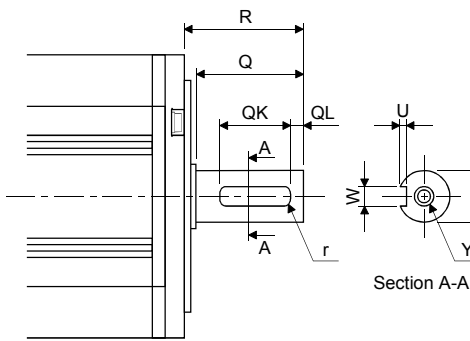

Variable dimension table

[Unit: mm]

Servo motor	Variable dimensions								
	S	R	Q	W	QK	QL	U	r	Y
HF-JP53(4)(B)K to 203(4)(B)K	16h6	40	30	5 <sup>0</sup> <sub>-0.030</sub>	25	2	3 <sup>+0.1</sup> <sub>0</sub>	2.5	M4 Depth 15
HF-JP353(4)(B)K • 503(4)(B)K	28h6	55	50	8 <sup>0</sup> <sub>-0.036</sub>	36	5	4 <sup>+0.2</sup> <sub>0</sub>	4	M8 Depth 20
HF-JP703(4)(B)K • 903(4)(B)K	35 <sup>+0.010</sup> <sub>0</sub>	79	75	10 <sup>0</sup> <sub>-0.036</sub>	55	5	5 <sup>+0.2</sup> <sub>0</sub>	5	M8 Depth 20
HF-JP11K1M(4)(B)K • HF-JP15K1M(4)(B)K	55M6	116	110	16 <sup>0</sup> <sub>-0.040</sub>	90	5	6 <sup>+0.2</sup> <sub>0</sub>	8	M10 Depth 27

Keyway shaft (without key)

### 12.5 Wiring option

Connector sets to use in power supply connector or brake connector are available as option.

For details of each connector set, cable and connector set to use in wiring to encoder, refer to the Servo Amplifier Instruction Manual for using.

Make sure to use the following power supply connector set for conforming to the IEC/EN compliant.

Servo motor	(Note) Power supply connector set	Brake connector set
HF-JP53 to 203 • 534 to 5034	MR-PWCNS4	MR-BKCNS1 (Straight type) Configuration products Straight plug : CM10-SP2S-L(D6) Socket contact : CM10-#22SC(S2)(D8)-100 (DDK)
HF-JP353 • 503	MR-PWCNS5	or MR-BKCNS1A (Angle type) Configuration products Angle plug : CM10-AP2S-L(D6) Socket contact : CM10-#22SC(S2)(D8)-100 (DDK)
HF-JP703(4) • 903(4)	MR-PWCNS3	MR-BKCN (Straight type) Configuration products Plug : D/MS3106A10SL-4S(D190) (DDK) Cable clamp : YSO10-5 to 8 (Daiwa Dengyo)
HF-JP11K1M(4) • 15K1M(4)	MR-PWCNS3	MR-BKCN (Straight type) Configuration products Plug : D/MS3106A10SL-4S(D190) (DDK) Cable clamp : YSO10-5 to 8 (Daiwa Dengyo)

Note. The configuration products for power supply connector set are as shown below.

MR-PWCNS4 (Plug: CE05-6A18-10SD-D-BSS Cable clamp: CE3057-10A-1-D)

MR-PWCNS5 (Plug: CE05-6A22-22SD-D-BSS Cable clamp: CE3057-12A-1-D)

MR-PWCNS3 (Plug: CE05-6A32-17SD-D-BSS Cable clamp: CE3057-20A-1-D)



## 12. HF-JP SERIES

### 12.6 Outline dimension drawings

Inertia moment on the table is the value calculated by converting the total value of inertia moment for servo motor, electromagnetic brake with servo motor shaft.

#### 12.6.1 Standard (without an electromagnetic brake)

Model	Output [kW]	Inertia moment J [ $\times 10^{-4} \text{kg} \cdot \text{m}^2$ ] ( $\text{WK}^2$ [oz · in <sup>2</sup> ])	Mass [kg] (lb)
HF-JP53	0.5	1.52 (8.31)	3.0 (6.61)
HF-JP534			

[Unit: mm]

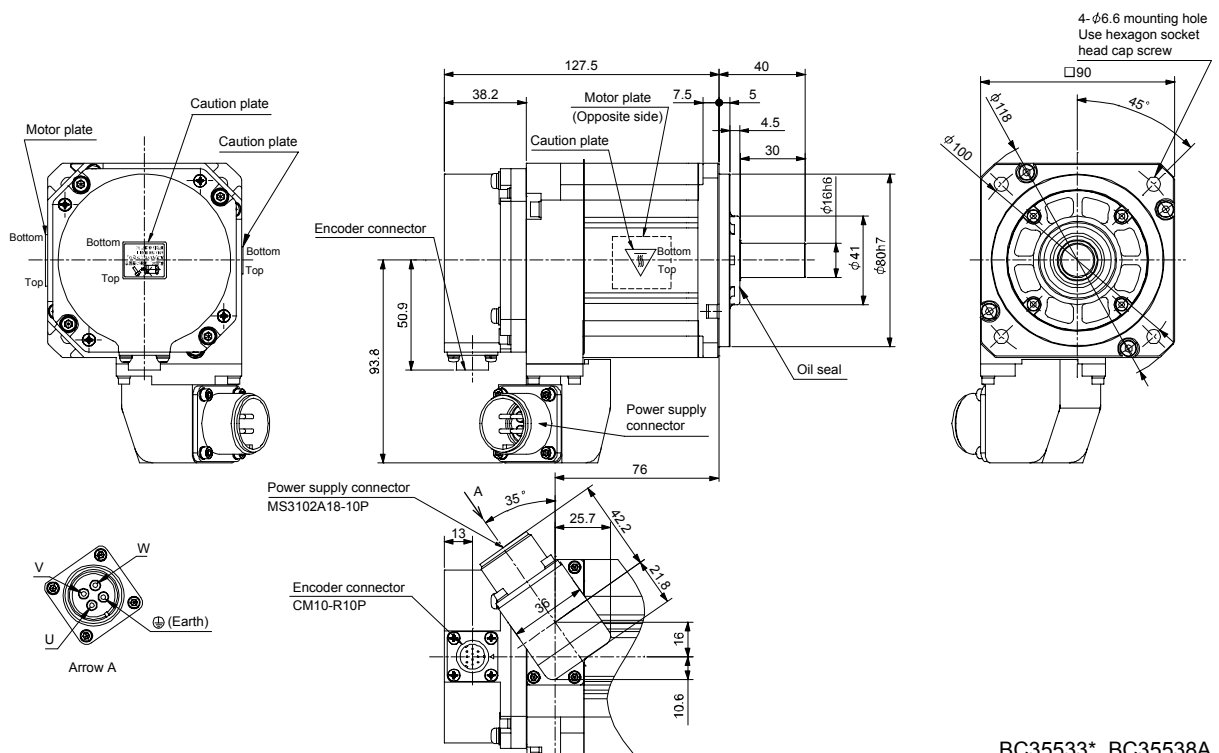

BC35533\* BC35538A

# 12. HF-JP SERIES

Model	Output [kW]	Inertia moment J [ $\times 10^{-4} \text{kg} \cdot \text{m}^2$ ] ( $\text{WK}^2$ [oz · in <sup>2</sup> ])	Mass [kg] (lb)
HF-JP73	0.75	2.09 (11.4)	3.7 (8.16)
HF-JP734			

[Unit: mm]

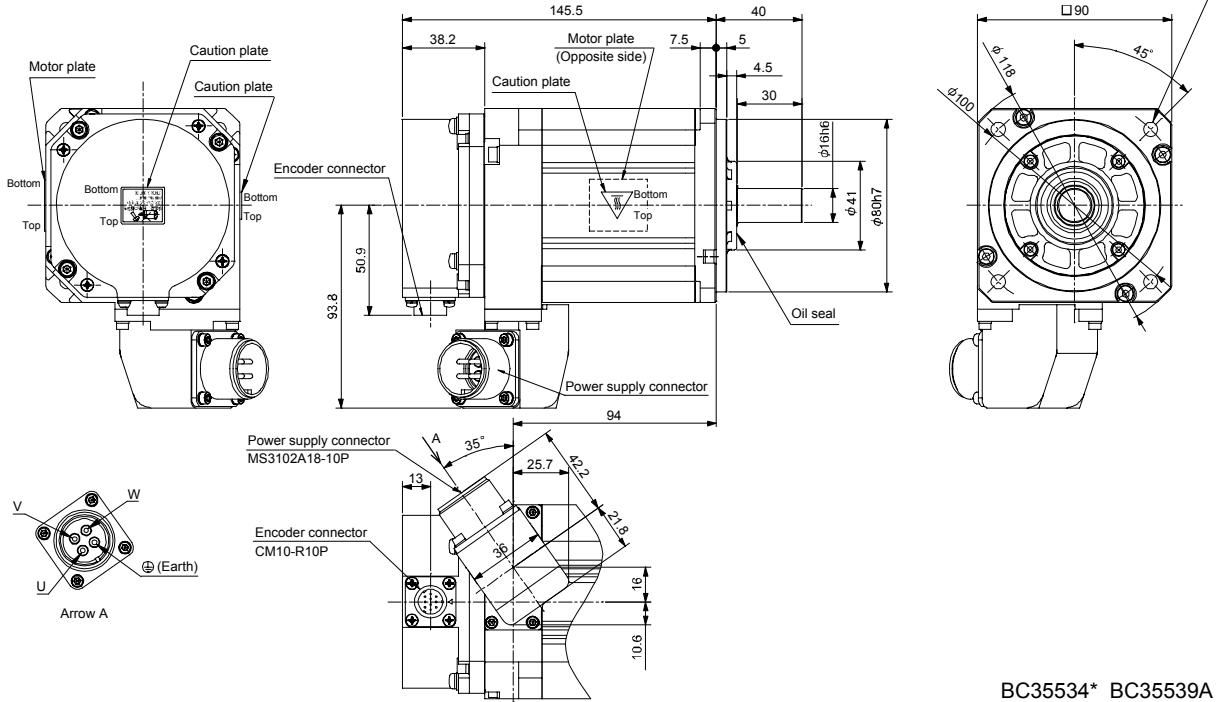

BC35534\* BC35539A

## 12. HF-JP SERIES

Model	Output [kW]	Inertia moment J [ $\times 10^{-4} \text{kg} \cdot \text{m}^2$ ] (WK <sup>2</sup> [oz · in <sup>2</sup> ])	Mass [kg] (lb)
HF-JP103	1.0	2.65 (14.5)	4.5 (9.92)
HF-JP1034			

[Unit: mm]

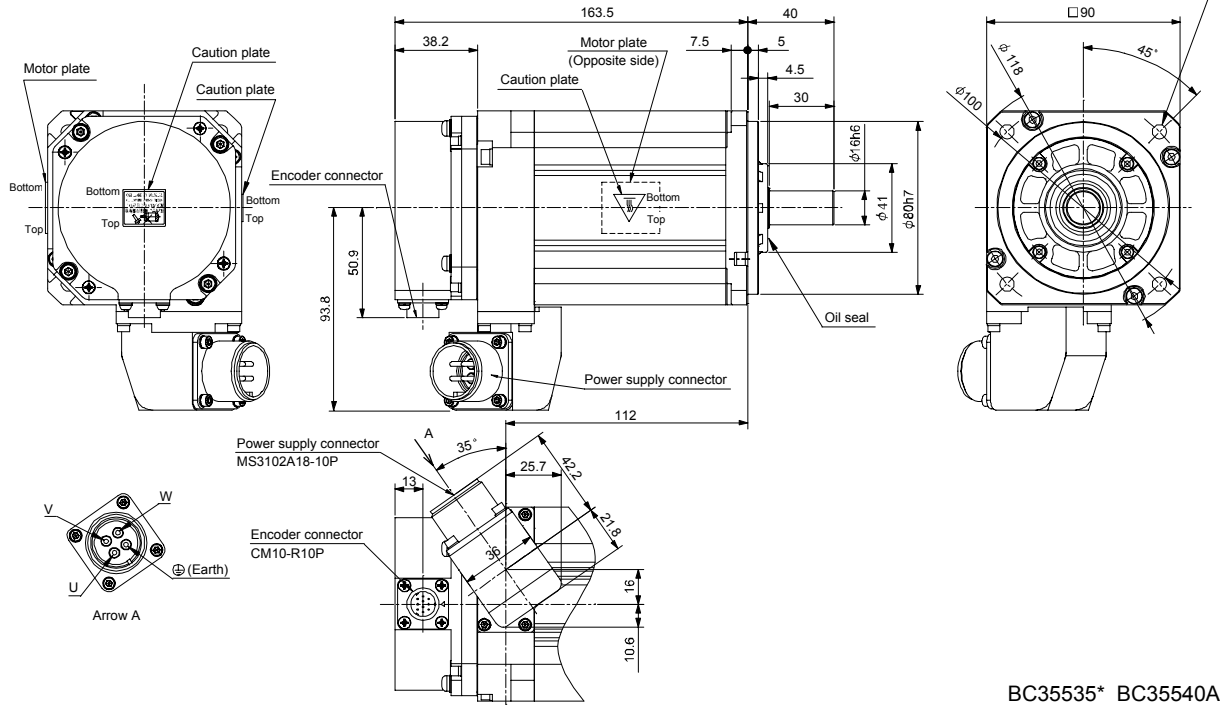

BC35535\* BC35540A

# 12. HF-JP SERIES

Model	Output [kW]	Inertia moment J [ $\times 10^{-4} \text{kg} \cdot \text{m}^2$ ] (WK <sup>2</sup> [oz · in <sup>2</sup> ])	Mass [kg] (lb)
HF-JP153	1.5	3.79 (20.7)	5.9 (13.0)
HF-JP1534			

[Unit: mm]

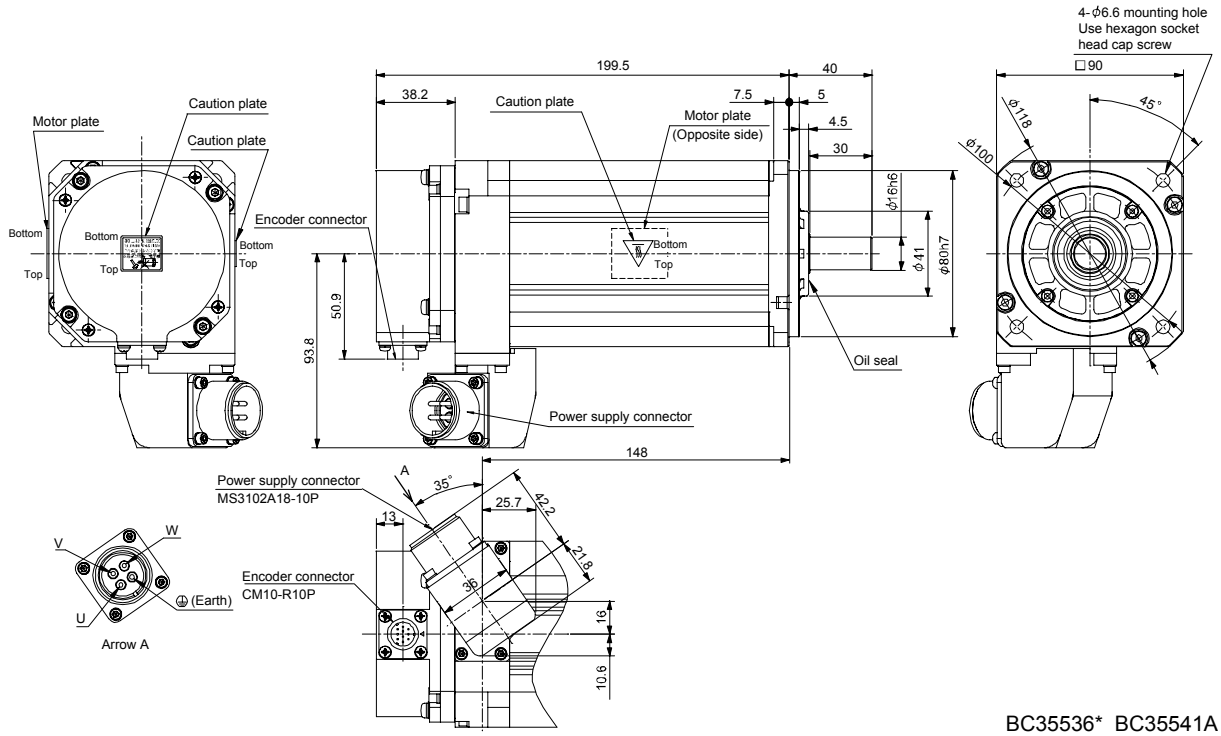

BC35536\* BC35541A

# 12. HF-JP SERIES

Model	Output [kW]	Inertia moment $J [\times 10^{-4} \text{kg} \cdot \text{m}^2]$ $(\text{WK}^2 [\text{oz} \cdot \text{in}^2])$	Mass [kg] (lb)
HF-JP203	2.0	4.92 (26.9)	7.5 (16.5)
HF-JP2034			

[Unit: mm]

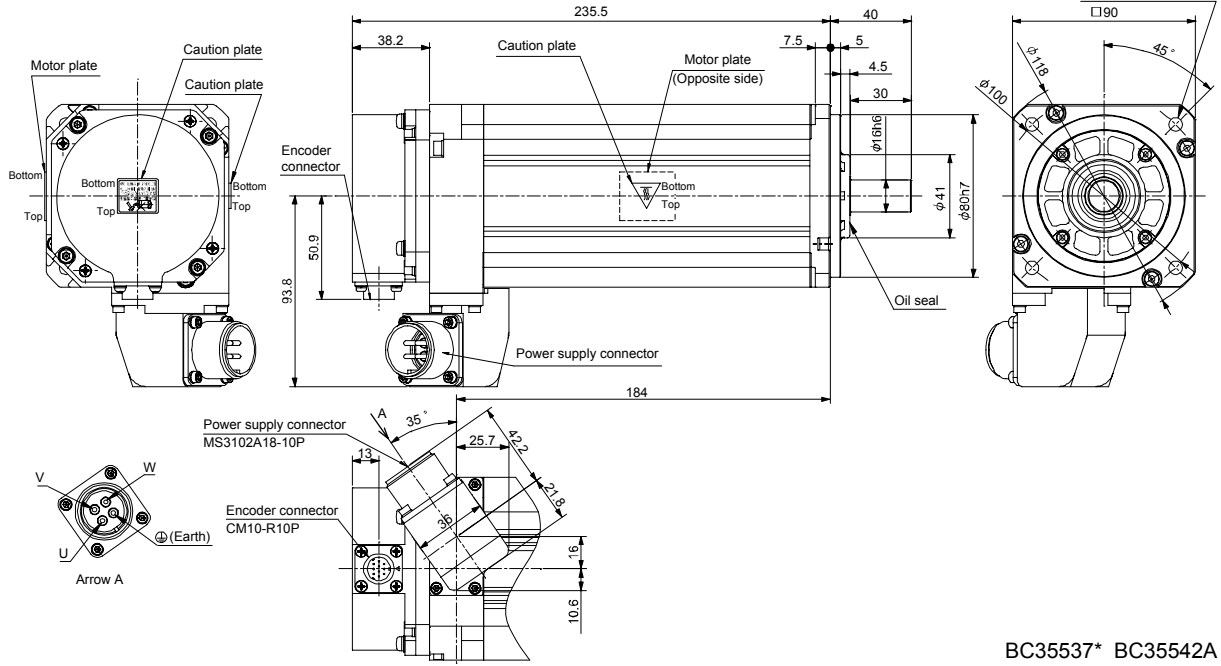

Model	Output [kW]	Inertia moment $J [\times 10^{-4} \text{kg} \cdot \text{m}^2]$ $(\text{WK}^2 [\text{oz} \cdot \text{in}^2])$	Mass [kg] (lb)
HF-JP353	3.5	13.2 (72.2)	13 (28.7)

[Unit: mm]

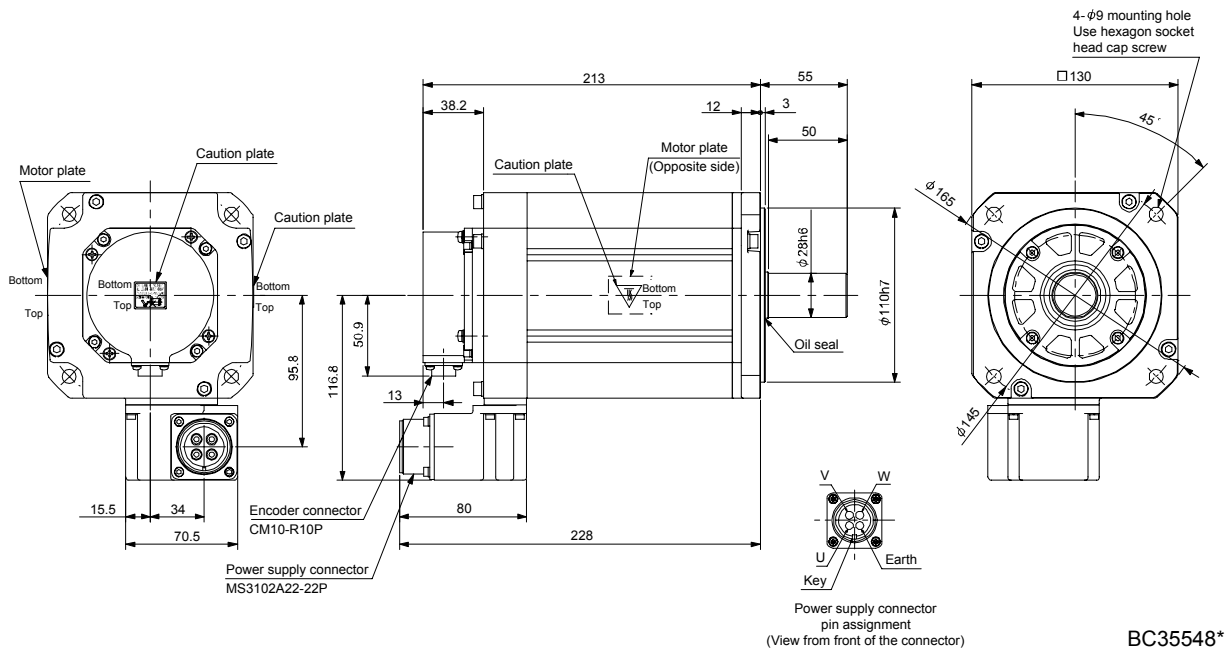

## 12. HF-JP SERIES

Model	Output [kW]	Inertia moment J [ $\times 10^{-4} \text{kg} \cdot \text{m}^2$ ] (WK <sup>2</sup> [oz · in <sup>2</sup> ])	Mass [kg] (lb)
HF-JP3534	3.5	13.2 (72.2)	13 (28.7)

[Unit: mm]

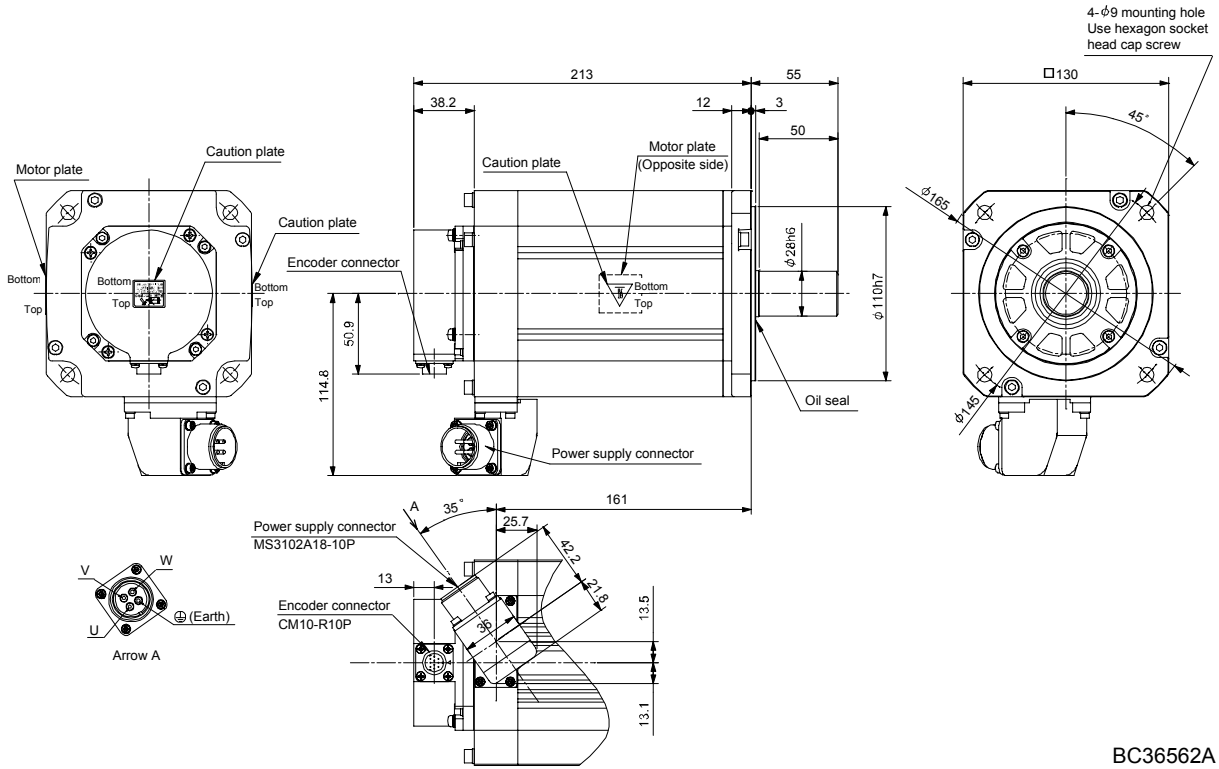

Model	Output [kW]	Inertia moment J [ $\times 10^{-4} \text{kg} \cdot \text{m}^2$ ] (WK <sup>2</sup> [oz · in <sup>2</sup> ])	Mass [kg] (lb)
HF-JP503	5.0	19.0 (104)	18 (39.7)

[Unit: mm]

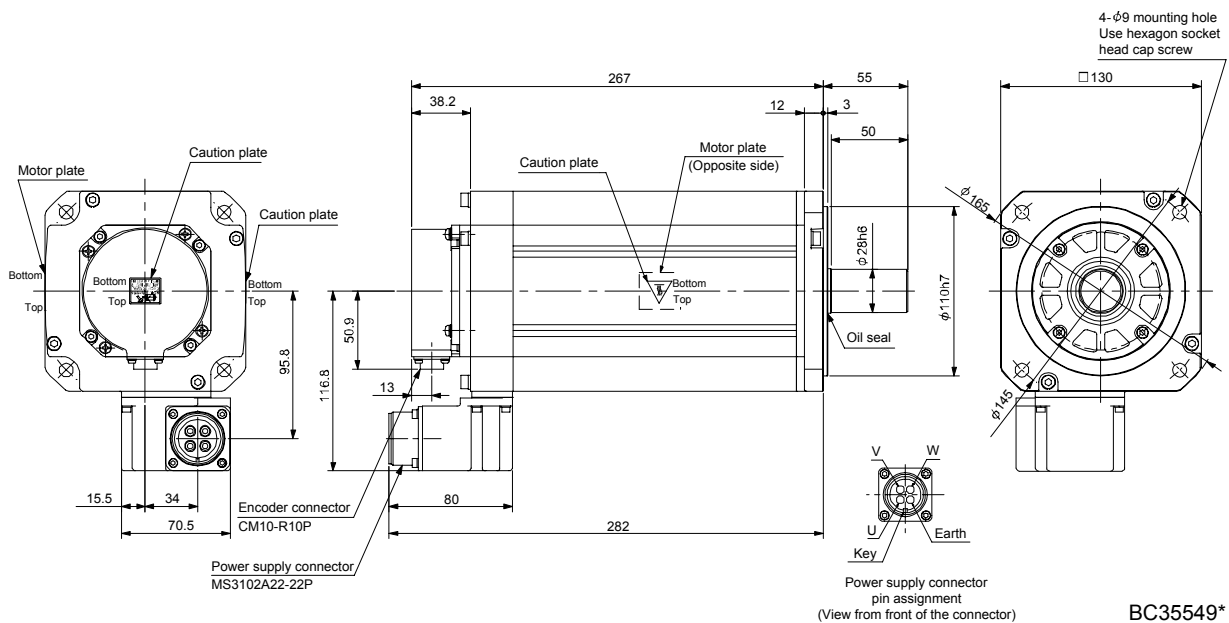

# 12. HF-JP SERIES

Model	Output [kW]	Inertia moment $J [\times 10^{-4} \text{kg} \cdot \text{m}^2]$ ( $\text{WK}^2 [\text{oz} \cdot \text{in}^2]$ )	Mass [kg] (lb)
HF-JP5034	5.0	19.0 (104)	18 (39.7)

[Unit: mm]

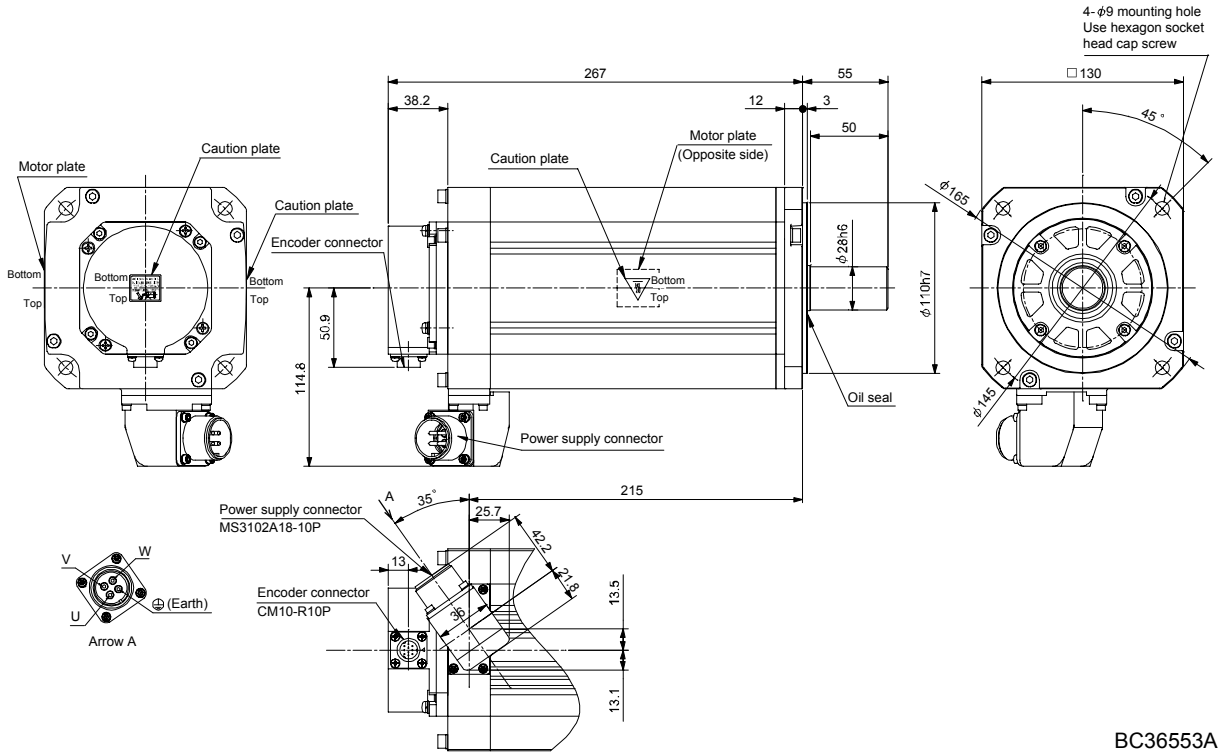

BC36553A

Model	Output [kW]	Inertia moment $J [\times 10^{-4} \text{kg} \cdot \text{m}^2]$ ( $\text{WK}^2 [\text{oz} \cdot \text{in}^2]$ )	Mass [kg] (lb)
HF-JP703	7.0	43.3 (237)	29 (63.9)
HF-JP7034			

[Unit: mm]

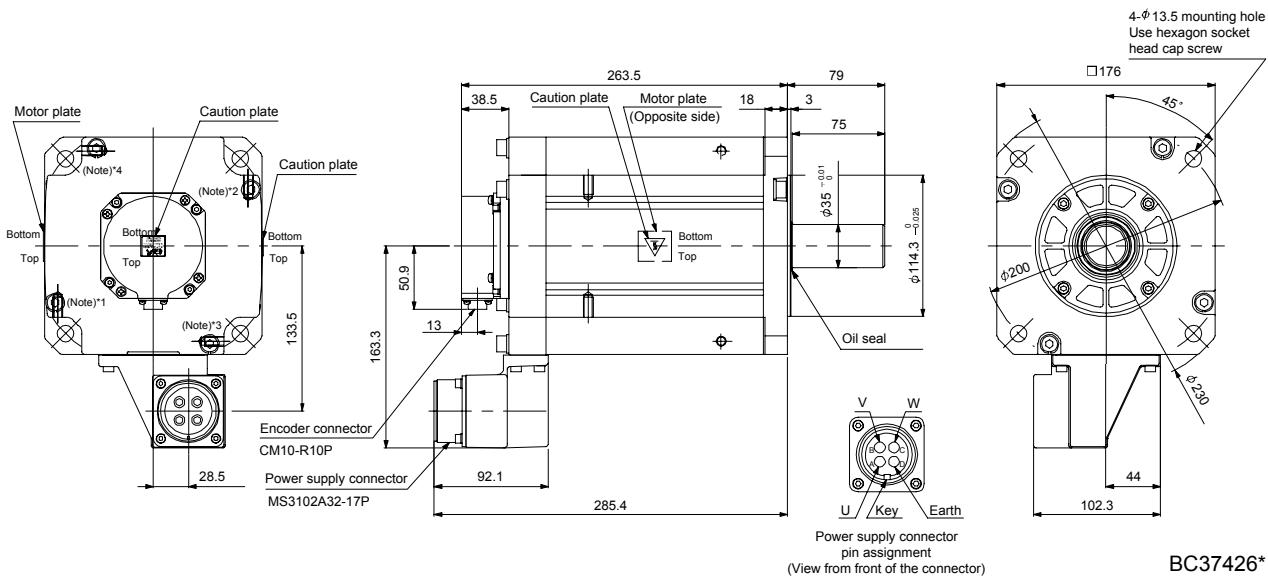

BC37426\*

Note. \*1, \*2, \*3 and \*4 are screw hole for eyebolt (M8).

## 12. HF-JP SERIES

Model	Output [kW]	Inertia moment J [ $\times 10^{-4} \text{kg} \cdot \text{m}^2$ ] (WK <sup>2</sup> [oz · in <sup>2</sup> ])	Mass [kg] (lb)
HF-JP903	9.0	55.8 (305)	36 (79.4)
HF-JP9034			

[Unit: mm]

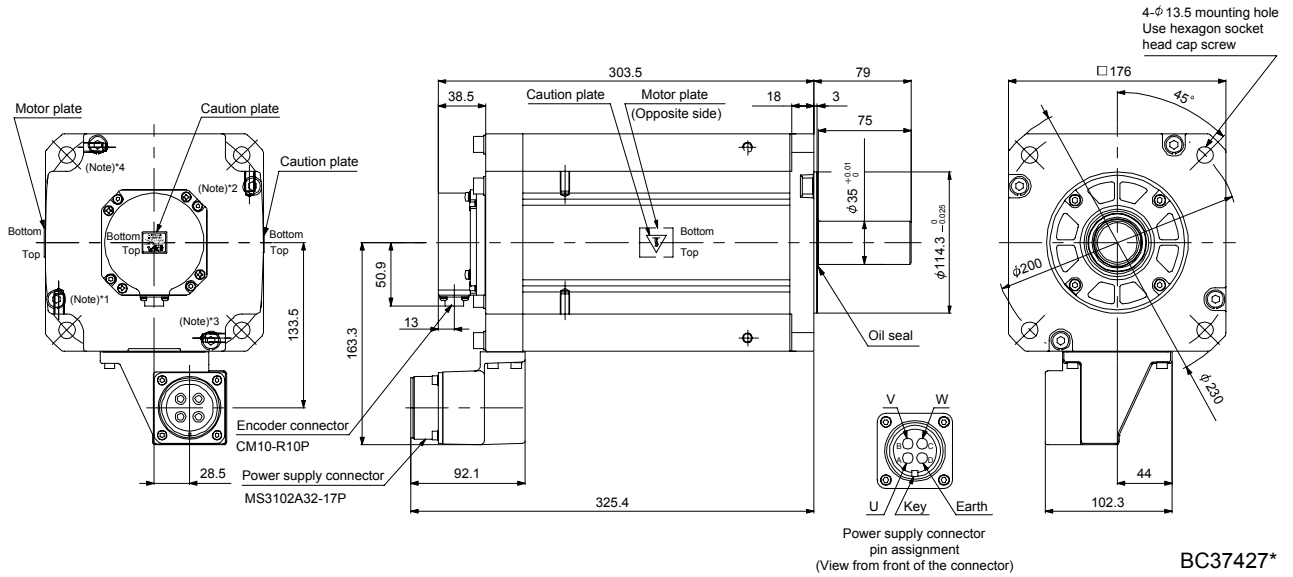

Note. \*1, \*2, \*3 and \*4 are screw hole for eyebolt (M8).



## 12. HF-JP SERIES

Model	Output [kW]	Inertia moment $J [ \times 10^{-4} \text{kg} \cdot \text{m}^2 ]$ $(\text{WK}^2 [\text{oz} \cdot \text{in}^2])$	Mass [kg] ([lb])
HF-JP11K1M	11	220 (1200)	62 (137)
HF-JP11K1M4			

[Unit: mm]

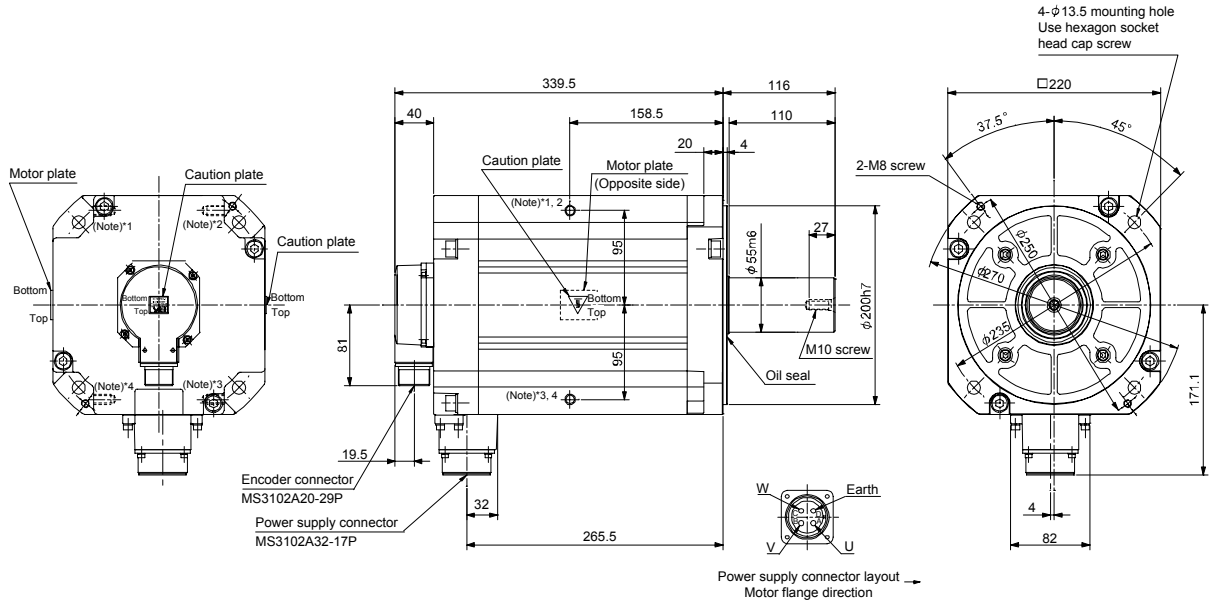

BC33586D

Note. \*1, \*2, \*3 and \*4 are screw hole for eyebolt (M10).

Model	Output [kW]	Inertia moment $J [ \times 10^{-4} \text{kg} \cdot \text{m}^2 ]$ $(\text{WK}^2 [\text{oz} \cdot \text{in}^2])$	Mass [kg] ([lb])
HF-JP15K1M	15	315 (1720)	86 (190)
HF-JP15K1M4			

[Unit: mm]

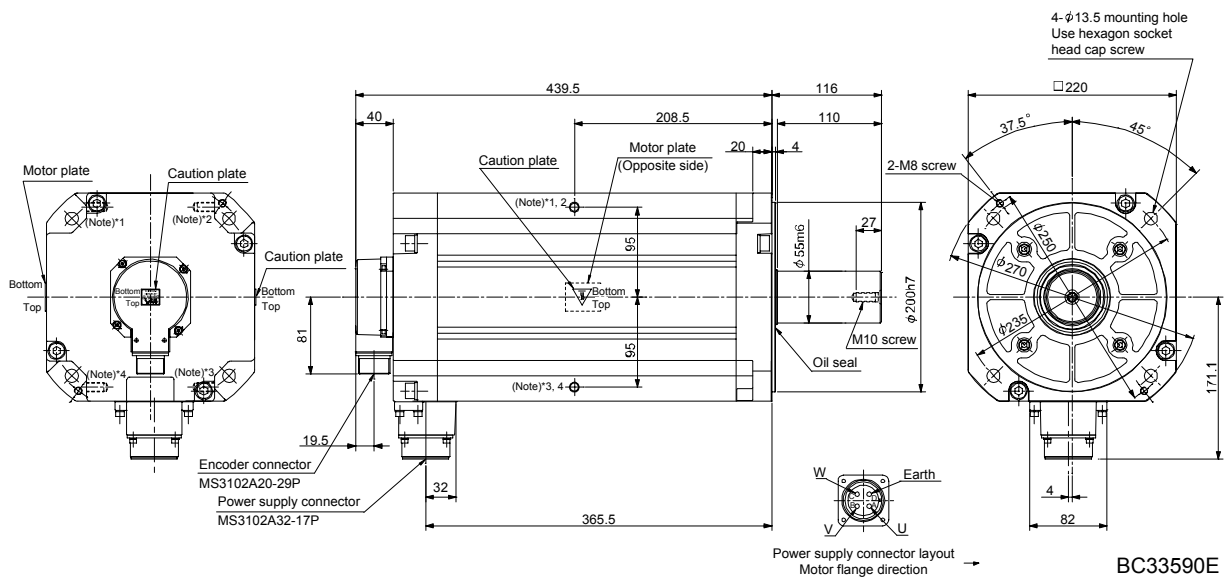

BC33590E

Note. \*1, \*2, \*3 and \*4 are screw hole for eyebolt (M10).



# 12. HF-JP SERIES

Model	Output [kW]	Brake static friction torque [N · m] (oz · in)	Inertia moment $J [ \times 10^{-4} \text{kg} \cdot \text{m}^2 ]$ ( $\text{WK}^2$ [oz · in <sup>2</sup> ])	Mass [kg] (lb)
HF-JP73B	0.75	6.6 (935)	2.59 (14.2)	5.1 (11.2)
HF-JP734B				

[Unit: mm]

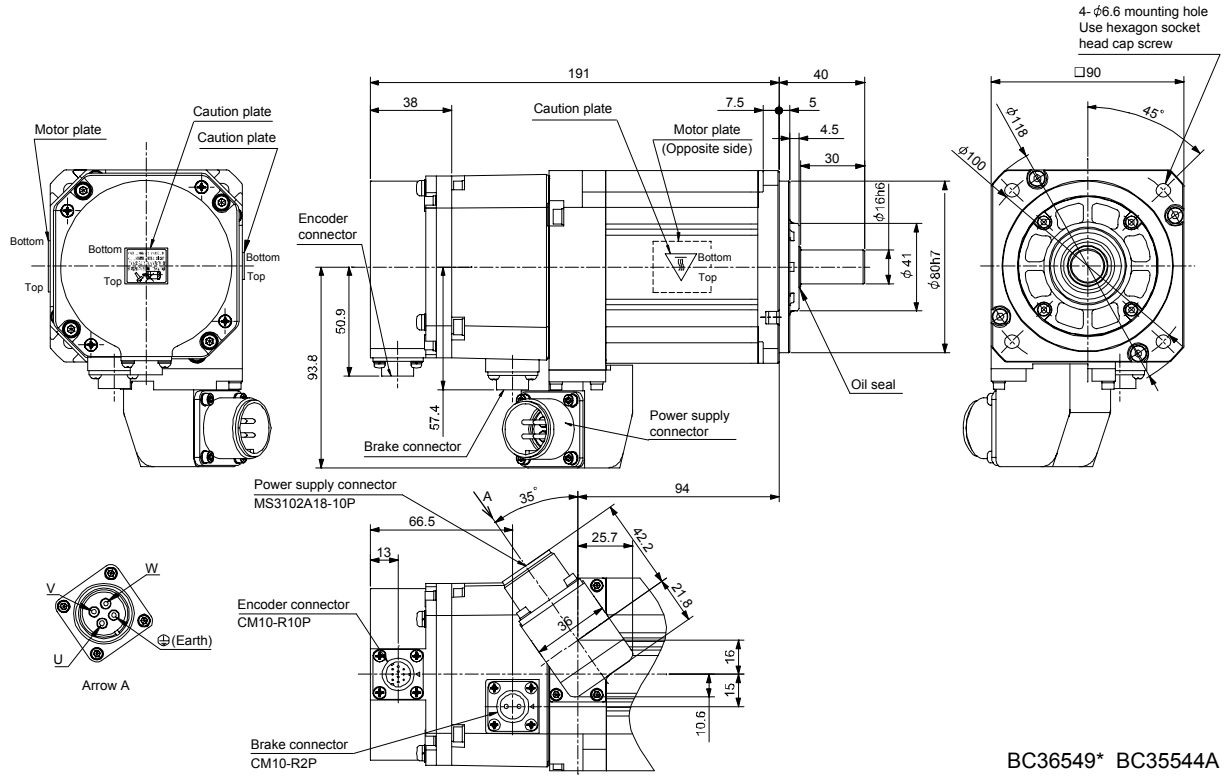

## 12. HF-JP SERIES

Model	Output [kW]	Brake static friction torque [N · m] (oz · in)	Inertia moment J [ $\times 10^{-4}$ kg · m <sup>2</sup> ] (WK <sup>2</sup> [oz · in <sup>2</sup> ])	Mass [kg] (lb)
HF-JP103B	1.0	6.6 (935)	3.15 (17.2)	5.9 (13.0)
HF-JP1034B				

[Unit: mm]

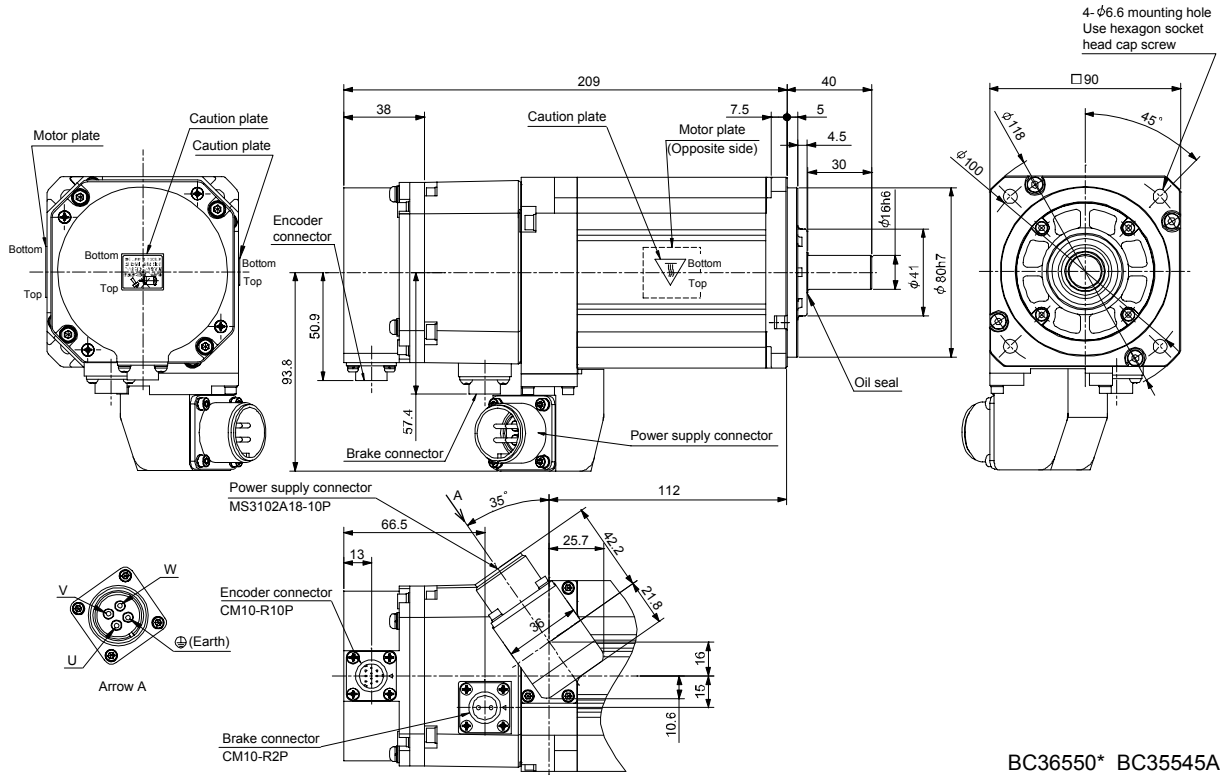

## 12. HF-JP SERIES

Model	Output [kW]	Brake static friction torque [N · m] (oz · in)	Inertia moment $J [ \times 10^{-4} \text{kg} \cdot \text{m}^2 ]$ (WK <sup>2</sup> [oz · in <sup>2</sup> ])	Mass [kg] (lb)
HF-JP153B	1.5	6.6 (935)	4.29 (23.5)	7.3 (16.1)
HF-JP1534B				

[Unit: mm]

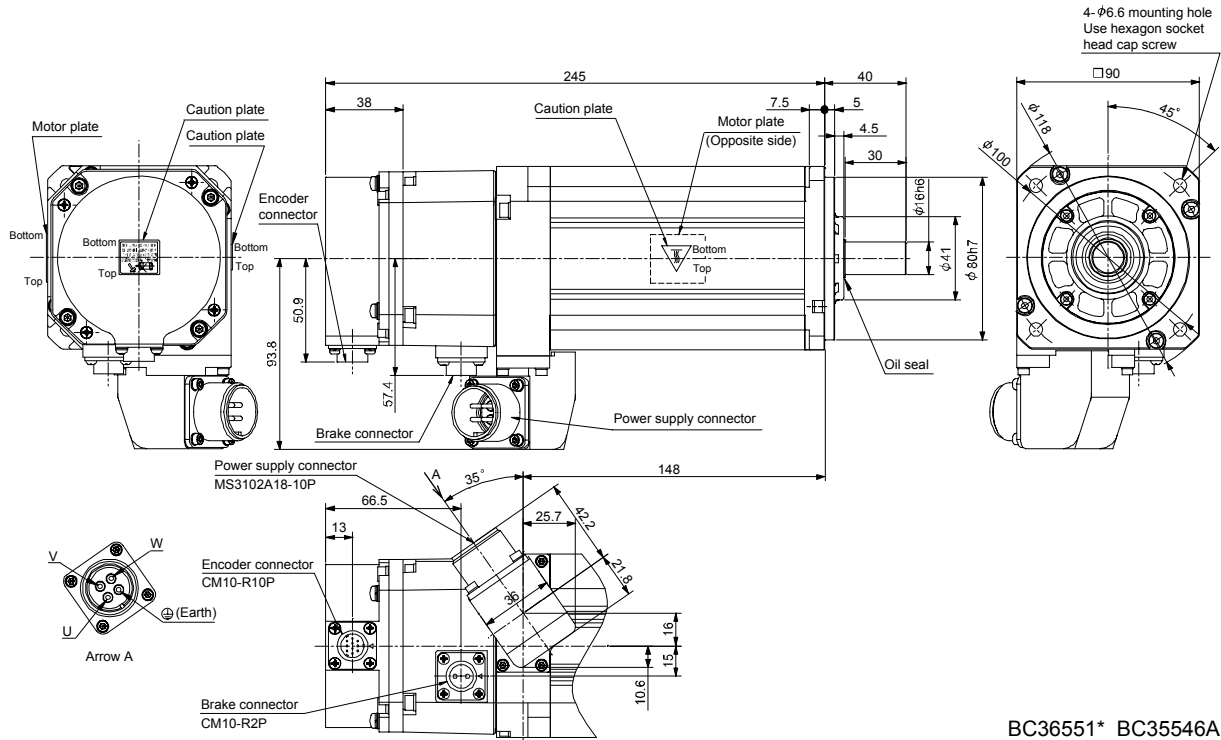

BC36551\* BC35546A



## 12. HF-JP SERIES

Model	Output [kW]	Brake static friction torque [N · m] (oz · in)	Inertia moment $J [ \times 10^{-4} \text{kg} \cdot \text{m}^2 ]$ ( $\text{WK}^2$ [oz · in <sup>2</sup> ])	Mass [kg] (lb)
HF-JP3534B	3.5	16.0 (2270)	15.4 (84.2)	15 (33.1)

[Unit: mm]

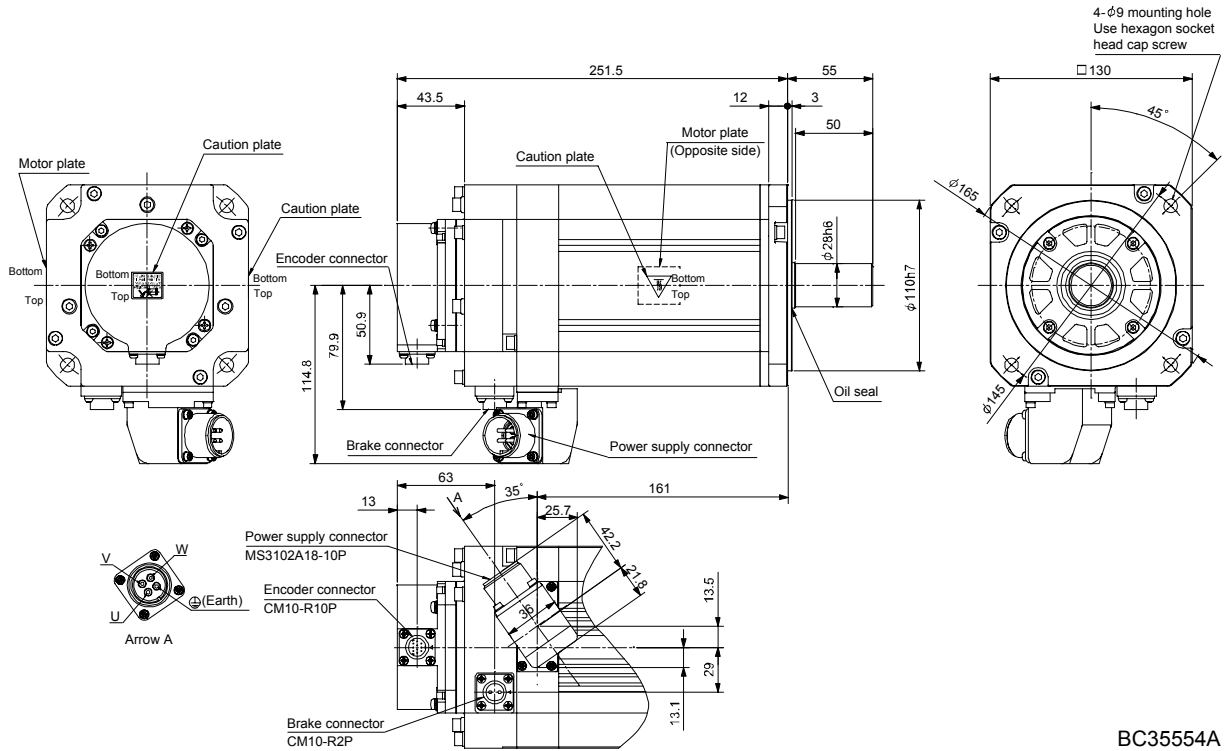

Model	Output [kW]	Brake static friction torque [N · m] (oz · in)	Inertia moment $J [ \times 10^{-4} \text{kg} \cdot \text{m}^2 ]$ ( $\text{WK}^2$ [oz · in <sup>2</sup> ])	Mass [kg] (lb)
HF-JP503B	5.0	16.0 (2270)	21.2 (116)	20 (44.1)

[Unit: mm]

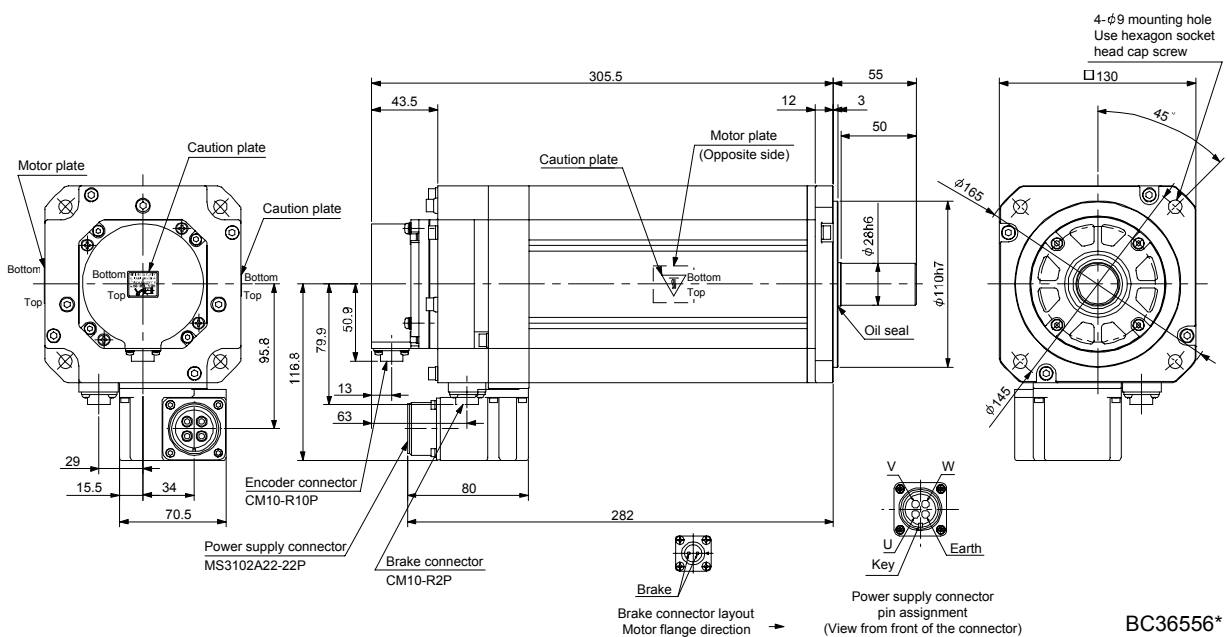

## 12. HF-JP SERIES

Model	Output [kW]	Brake static friction torque [N · m] (oz · in)	Inertia moment $J [ \times 10^{-4} \text{kg} \cdot \text{m}^2 ]$ (WK <sup>2</sup> [oz · in <sup>2</sup> ])	Mass [kg] (lb)
HF-JP5034B	5.0	16.0 (2270)	21.2 (116)	20 (44.1)

[Unit: mm]

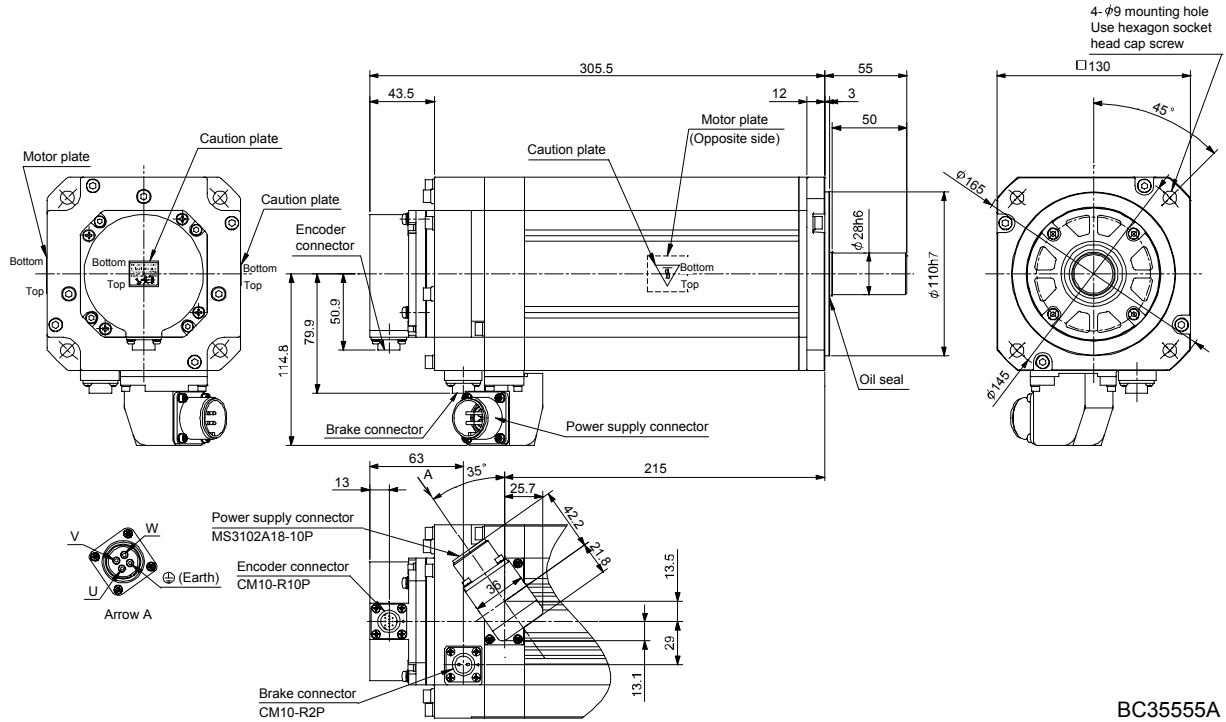

BC35555A



## 12. HF-JP SERIES

Model	Output [kW]	Brake static friction torque [N · m] (oz · in)	Inertia moment J [ $\times 10^{-4}$ kg · m <sup>2</sup> ] (WK <sup>2</sup> [oz · in <sup>2</sup> ])	Mass [kg] (lb)
HF-JP703B	7.0	44	52.9 (289)	35 (77.2)
HF-JP7034B				

[Unit: mm]

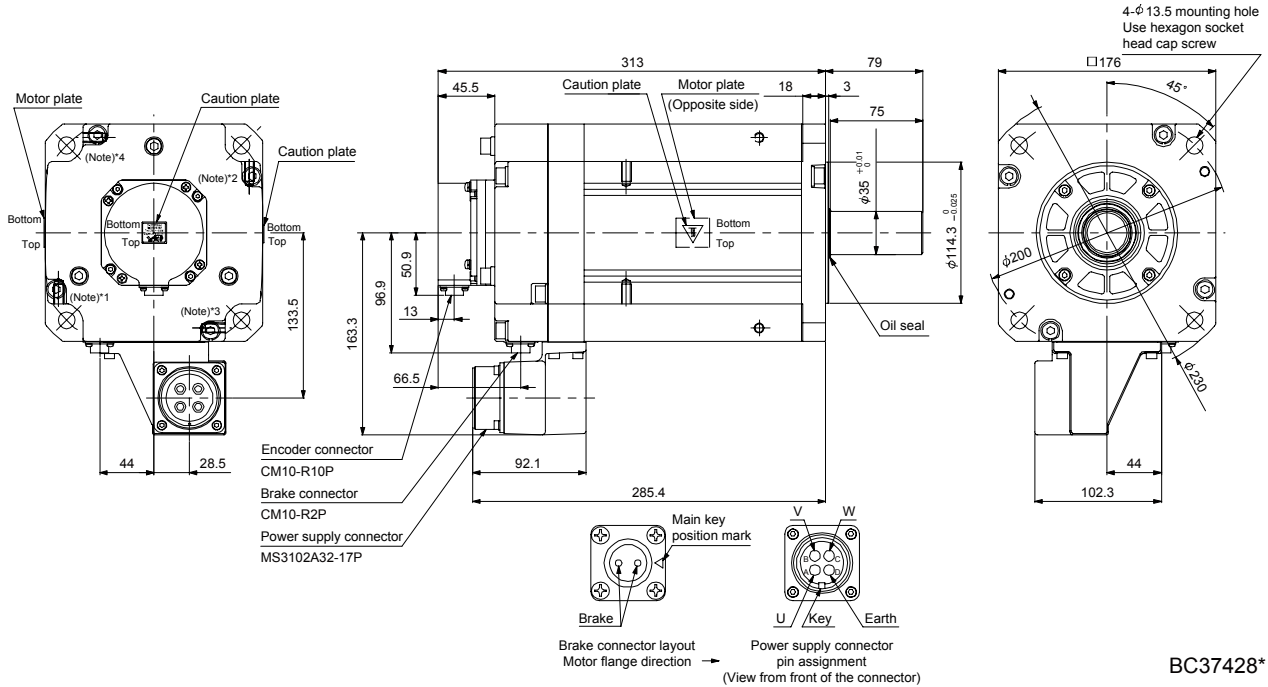

Note. \*1, \*2, \*3 and \*4 are screw hole for eyebolt (M8).

Model	Output [kW]	Brake static friction torque [N · m] (oz · in)	Inertia moment J [ $\times 10^{-4}$ kg · m <sup>2</sup> ] (WK <sup>2</sup> [oz · in <sup>2</sup> ])	Mass [kg] (lb)
HF-JP903B	9.0	44	65.4 (358)	42 (92.6)
HF-JP9034B				

[Unit: mm]

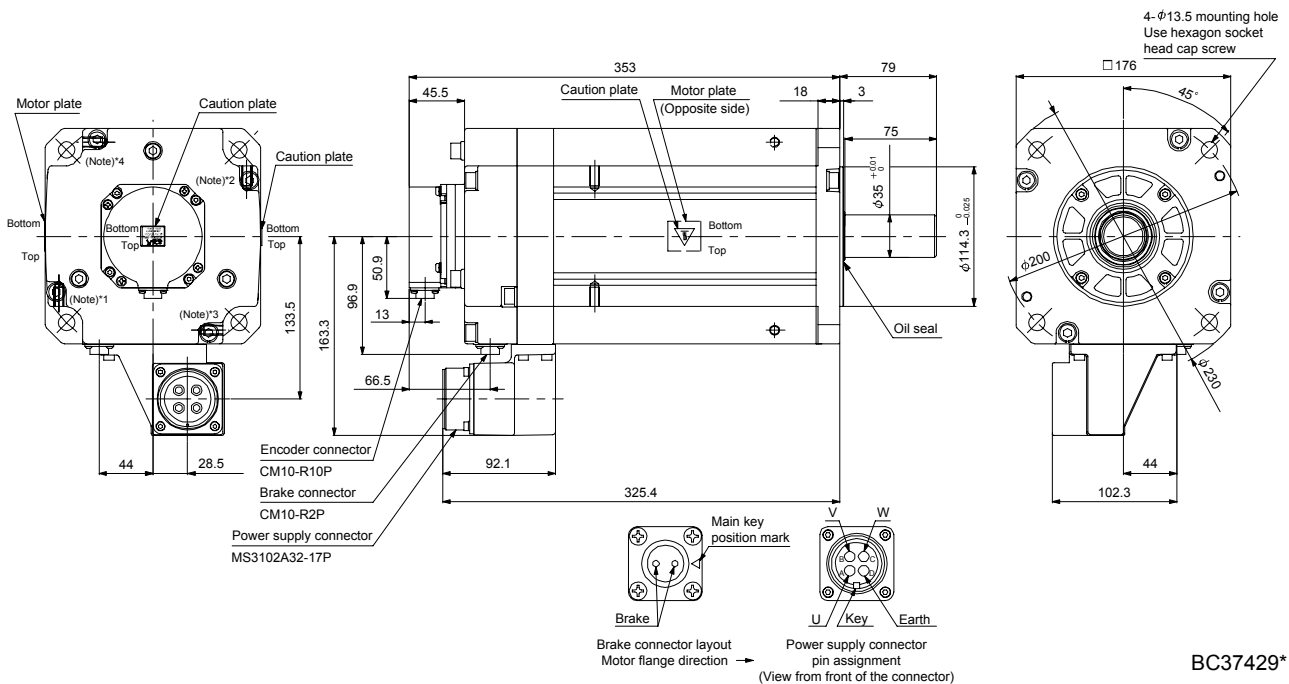

Note. \*1, \*2, \*3 and \*4 are screw hole for eyebolt (M8).

## 12. HF-JP SERIES

Model	Output [kW]	Brake static friction torque [N · m] (oz · in)	Inertia moment $J [ \times 10^{-4} \text{kg} \cdot \text{m}^2 ]$ ( $\text{WK}^2$ [oz · in <sup>2</sup> ])	Mass [kg] (lb)
HF-JP11K1MB	11	126 (17800)	240 (1310)	74 (163)
HF-JP11K1M4B				

[Unit: mm]

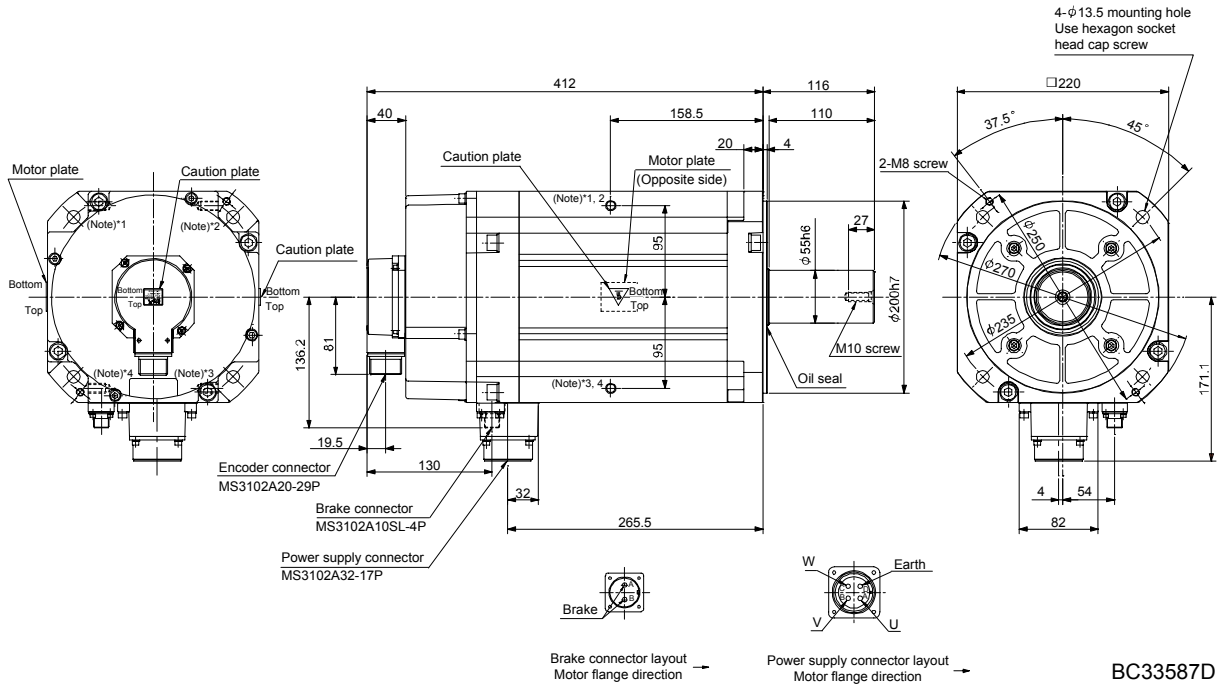

BC33587D

Note. \*1, \*2, \*3 and \*4 are screw hole for eyebolt (M10).

Model	Output [kW]	Brake static friction torque [N · m] (oz · in)	Inertia moment $J [ \times 10^{-4} \text{kg} \cdot \text{m}^2 ]$ ( $\text{WK}^2$ [oz · in <sup>2</sup> ])	Mass [kg] (lb)
HF-JP15K1MB	15	126 (17800)	336 (1840)	97 (214)
HF-JP15K1M4B				

[Unit: mm]

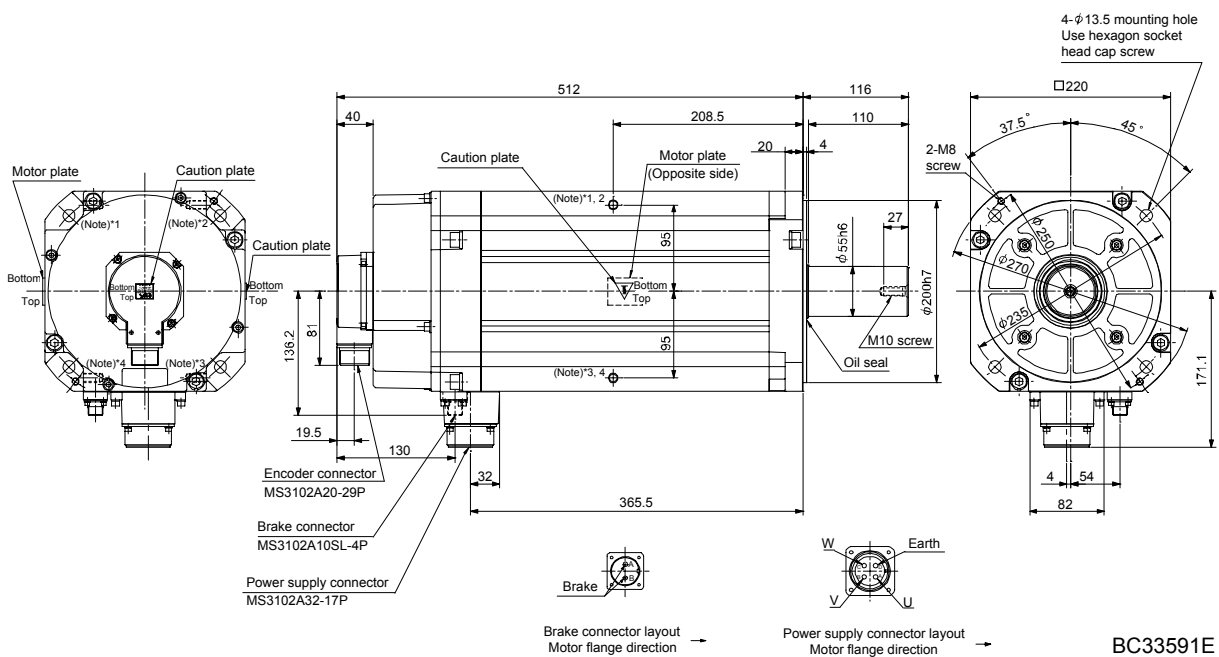

BC33591E

Note. \*1, \*2, \*3 and \*4 are screw hole for eyebolt (M10).

## 12. HF-JP SERIES

---

### 12.7 Servo motor with oil seal

For the servo motor with oil seal, the oil seal prevents the entry of oil into the servo motor. Install the servo motor horizontally, and set the oil level in the gear box to be lower than the oil seal lip always.

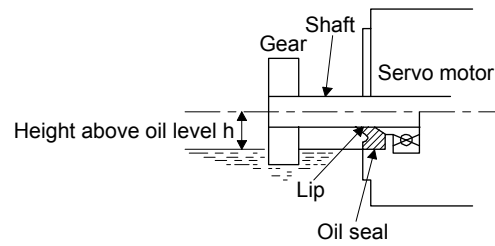

Servo motor	Height above oil level h [mm]
HF-JP53(4) · 73(4) · 103(4) · 153(4) · 203(4)	18
HF-JP353(4) · 503(4)	20
HF-JP703(4) · 903(4)	25
HF-JP11K1M(4) · 15K1M(4)	40

# 13. HG-AK SERIES

## 13. HG-AK SERIES

This chapter provides information on the servo motor specifications and characteristics. When using the HG-AK series servo motor, always read the Safety Instructions in the beginning of this manual and chapters 1 to 4, in addition to this chapter.

### 13.1 Model name make up

The following describes model designation. Not all combinations of the symbols are available.

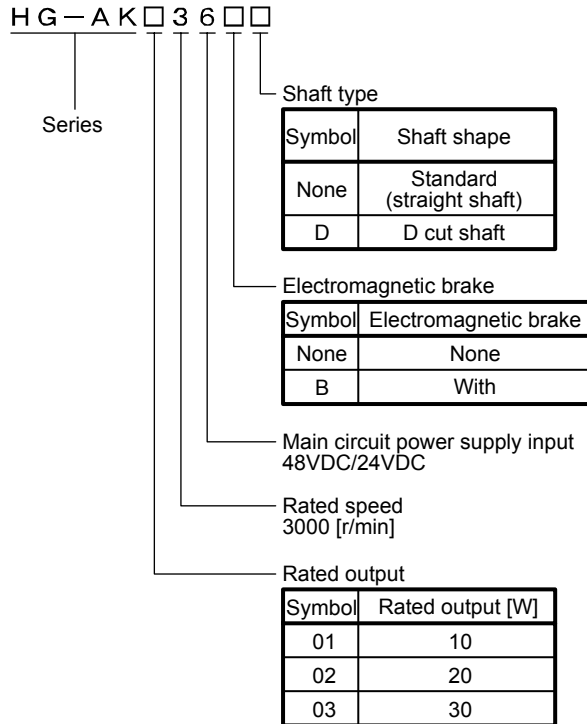

Appearance

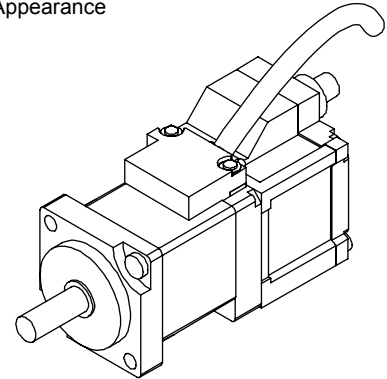

## 13. HG-AK SERIES

### 13.2 Standard specifications

#### 13.2.1 Standard specifications list

Item		Servo motor		HG-AK series		
				0136(B)	0236(B)	0336(B)
Applicable servo amplifier		MR-J3W-0303BN6				
Power supply capacity		Refer to "Power supply equipment capacity and generated loss of servo amplifiers" in Servo Amplifier Instruction Manual.				
Continuous running duty (Note 1)	Rated output	[W]	10	20	30	
	Rated torque	[N · m]	0.032	0.064	0.095	
		[oz · in]	4.53	9.06	13.5	
Maximum torque	[N · m]	0.095	0.191	0.286		
	[oz · in]	13.5	27.0	40.5		
Rated speed (Note 1)		[r/min]	3000			
Maximum speed	48VDC	[r/min]	6000			
	24VDC	[r/min]	6000	5000		
Instantaneous permissible speed	48VDC	[r/min]	6900			
	24VDC	[r/min]	6900	5750		
Power rate at continuous rated torque	Standard	[kW/s]	3.54	9.01	14.95	
	With electromagnetic brake	[kW/s]	2.41	6.99	12.32	
Rated current		[A]	2.1	2.1	2.2	
Maximum current		[A]	6.3	6.3	6.6	
Moment of inertia	Standard	$J [\times 10^{-4} \text{kg} \cdot \text{m}^2]$	0.0029	0.0045	0.0061	
		$WK^2 [\text{oz} \cdot \text{in}^2]$	0.016	0.025	0.033	
	With electromagnetic brake	$J [\times 10^{-4} \text{kg} \cdot \text{m}^2]$	0.0042	0.0058	0.0074	
		$WK^2 [\text{oz} \cdot \text{in}^2]$	0.023	0.032	0.040	
Recommended load to motor inertia ratio (Note 2)		30 times or less				
Speed/position detector		18-bit encoder common to absolute position/incremental systems (resolution per servo motor revolution: 262144pulses/rev)				
Oil seal		None				
Insulation class		130(B)				
Structure		Totally enclosed, natural cooling (IP rating: IP55 (Note 3))				
Environment (Note 4)	Ambient temperature	Operation	[°C]	0 to 40 (non-freezing)		
			[°F]	32 to 104 (non-freezing)		
		Storage	[°C]	-15 to 70 (non-freezing)		
			[°F]	5 to 158 (non-freezing)		
	Ambient humidity	Operation	80%RH or less (non-condensing)			
		Storage	90%RH or less (non-condensing)			
	Ambience	Indoors (no direct sunlight), free from corrosive gas, flammable gas, oil mist, dust, and dirt				
	Altitude	1000 m or less above sea level				
Vibration resistance (Note 5)	X, Y: 49m/s <sup>2</sup>					
Vibration rank (Note 6)		V10				
Permissible load for the shaft (Note 7)	L	[mm]	16			
	Radial	[N]	34	44	49	
		[lb]	7.64	9.89	11.0	
	Thrust	[N]	14			
		[lb]	3.15			

### 13. HG-AK SERIES

Servo motor			HG-AK series		
			0136(B)	0236(B)	0336(B)
Mass	Standard	[kg]	0.12	0.14	0.16
		[lb]	0.27	0.31	0.35
	With electromagnetic brake	[kg]	0.22	0.24	0.26
		[lb]	0.49	0.53	0.57

- Note 1. When the power supply voltage drops, the output and the rated speed cannot be guaranteed.
2. If the load to motor inertia ratio exceeds the indicated value, contact your local sales office.
3. Except for the shaft-through, connector, and power cable outlet portion.
4. In the environment where the servo motor is exposed to oil mist, oil and/or water, the servo motor of the standard specifications may not be usable. Please contact your local sales office for more details.
5. The vibration direction is as shown in the figure. The value is the one at the part that indicates the maximum value (normally the opposite to load-side bracket). When the servo motor stops, fretting is likely to occur at the bearing. Therefore, suppress the vibration to about half of the permissible value.

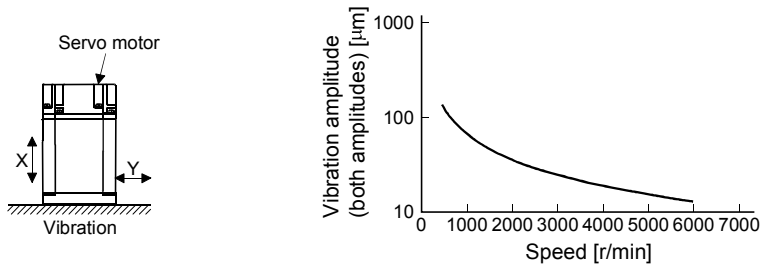

6. V10 indicates that the amplitude of a single servo motor is 10<sup>4</sup>μm or less. The following figure shows the servo motor mounting position for measurement and the measuring position.

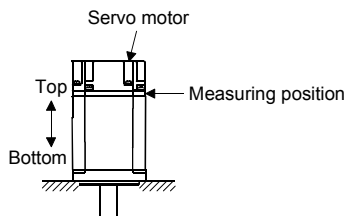

7. For the symbols in the table, refer to the following diagram: Do not subject the shaft to load greater than the value. The value in the table assumes that the load is applied independently.

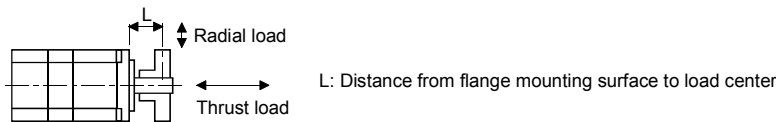

## 13. HG-AK SERIES

### 13.2.2 Torque characteristics

POINT
<ul style="list-style-type: none"> <li>▪ For the system where the unbalanced torque occurs, such as a vertical axis system, it is recommended that the unbalanced torque of the machine be kept at 70% or less of the motor's rated torque.</li> <li>▪ For the torque characteristics, MR-J3W03PWCBL5M-A-H or MR-J3W03PWBRCBL5M-A-H was used for connecting servo amplifiers and servo motors.</li> <li>▪ When the main circuit power supply input of the servo amplifier is 24VDC for HG-AK0336, the maximum speed will be 5000r/min.</li> </ul>

When the main power supply input of the servo amplifier is 48VDC, the torque characteristic is indicated by the heavy line. For 24VDC, part of the torque characteristic is indicated by the thin line.

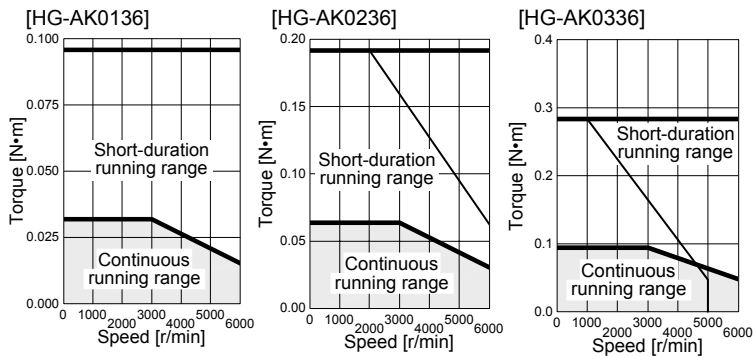

## 13. HG-AK SERIES

### 13.3 Electromagnetic brake characteristics



#### CAUTION

- The electromagnetic brake is provided to prevent a drop at a power failure or servo alarm occurrence during vertical drive or to hold a shaft at a stop. Do not use it for normal braking (including braking at servo-lock).
- Before operating the servo motor, be sure to confirm that the electromagnetic brake operates properly.
- The operation time of the electromagnetic brake differs depending on the power supply circuit you use. Be sure to check the operation delay time with a real machine.

The characteristics of the electromagnetic brake provided for the servo motor with an electromagnetic brake are indicated below.

Item	Servo motor		HG-AK series		
			0136B	0236B	0336B
Type (Note 1)	Spring-loaded safety brake				
Rated voltage (Note 4)	24VDC <sup>0</sup> <sub>-10%</sub>				
Power consumption	[W] at20°C (68°F)		1.8		
Coil resistance (Note 6)	[Ω] at20°C		320		
Inductance (Note 6)	[H]		1.6		
Brake static friction torque	[N · m]		0.095		
	[oz · in]		13.5		
Release delay time (Note 2)	[s]		0.03		
Braking delay time (Note 2)	[s]	DC off	0.01		
Permissible braking work	Per braking [J]		4.6		
	Per hour [J]		46		
Brake looseness at servo motor shaft (Note 5)	[degrees]		0.1 to 2.5		
Brake life (Note 3)	Number of brakings [times]		20000		
	Work per braking [J]		1		
Selection example of surge absorbers to be used (Note 7,8)	For the suppressed voltage 125V		TND20V-680KB		
	For the suppressed voltage 350V		TND10V-221KB		

Note 1. There is no manual release mechanism. When it is necessary to hand-turn the servo motor shaft for machine centering, etc., use a separate 24VDC power supply to release the brake electrically.

2. The value for initial on gap at 20°C.

3. The brake gap will increase as the brake lining wears, but the gap is not adjustable. The brake life indicated is the number of braking cycles after which adjustment will be required.

4. Always prepare a power supply exclusively used for the electromagnetic brake.

5. These are initial values. These are not guaranteed values.

6. These values are measured values and not guaranteed values.

7. Select the electromagnetic brake control relay properly, considering the characteristics of the electromagnetic brake and surge absorber.

8. Nippon Chemi-Con Corporation.



## 13. HG-AK SERIES

### 13.4 Servo motors with special shafts

The servo motors with special shafts indicated by the symbol(D) in the table is available. "D" is the symbol attached to the servo motor model names.

Servo motor	Shaft shape
	D cut shaft
HG-AK□(B)	D

[Unit: mm]

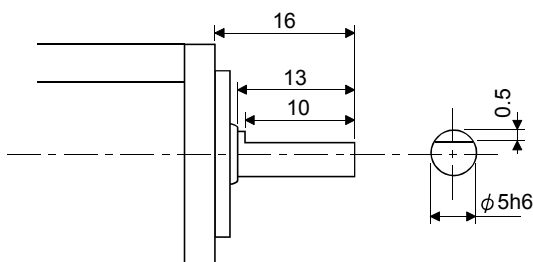

### 13.5 Wiring option

Connector sets to use in power supply connector or brake connector are available as option. For details of each cable, cable and connector set to use in wiring to encoder, refer to the Servo Amplifier Instruction Manual for using. Make sure to use the following power supply cable for conforming to the IEC/EN Standard compliant.

Servo motor	Servo motor power cable
HG-AK series	MR-J3W03PWCBL□M-A-H
	MR-J3W03PWBRCBL□M-A-H

### 13.6 Dimensions

The dimensions without tolerances are reference dimensions.

Inertia moment on the table is the value calculated by converting the total value of inertia moment for servo motor, electromagnetic brake and decelerator with servo motor shaft.

# 13. HG-AK SERIES

## 13.6.1 Standard (without an electromagnetic brake)

Model	Output [kW]	Inertia moment J [ $\times 10^{-4} \text{kg} \cdot \text{m}^2$ ] ( $\text{WK}^2$ [oz · in <sup>2</sup> ])	Mass [kg] (lb)
HG-AK0136	10	0.0029 (0.016)	0.12 (0.27)

[Unit: mm]

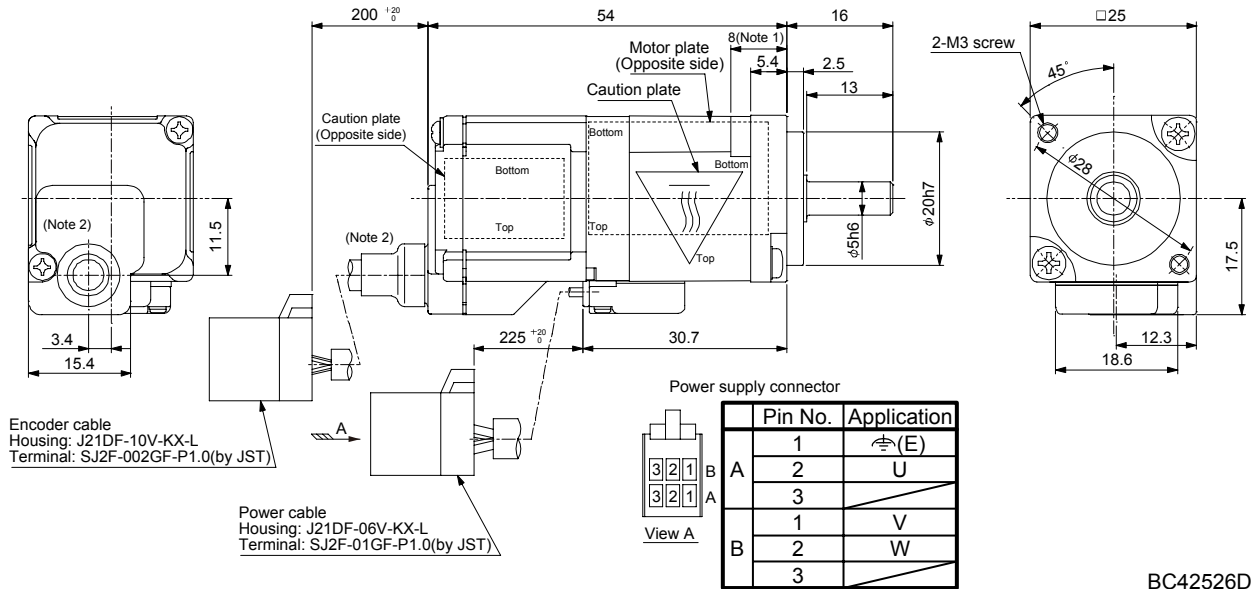

Note 1. The length of mounting screw should be within this.

2. The encoder cable outlet portion change has been sequentially applied from the April 2013 production of the motors.

Model	Output [kW]	Inertia moment J [ $\times 10^{-4} \text{kg} \cdot \text{m}^2$ ] ( $\text{WK}^2$ [oz · in <sup>2</sup> ])	Mass [kg] (lb)
HG-AK0236	20	0.0045 (0.025)	0.14 (0.31)

[Unit: mm]

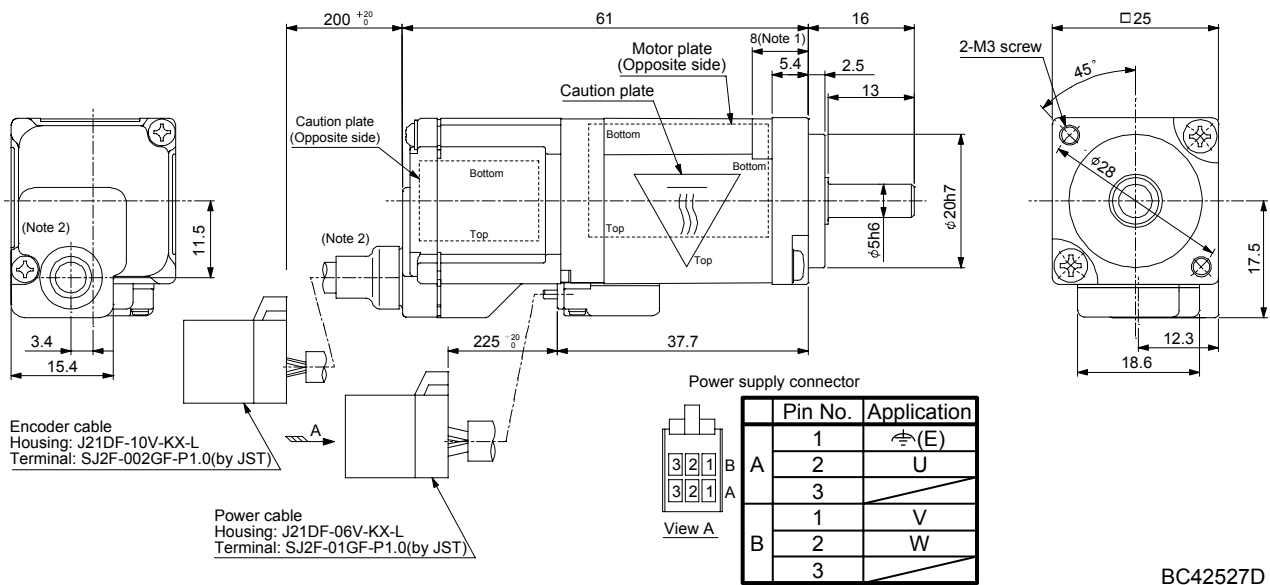

Note 1. The length of mounting screw should be within this.

2. The encoder cable outlet portion change has been sequentially applied from the April 2013 production of the motors.

### 13. HG-AK SERIES

Model	Output [kW]	Inertia moment J [ $\times 10^{-4}$ kg · m <sup>2</sup> ] (WK <sup>2</sup> [oz · in <sup>2</sup> ])	Mass [kg] (lb)
HG-AK0336	30	0.0061 (0.033)	0.16 (0.35)

[Unit: mm]

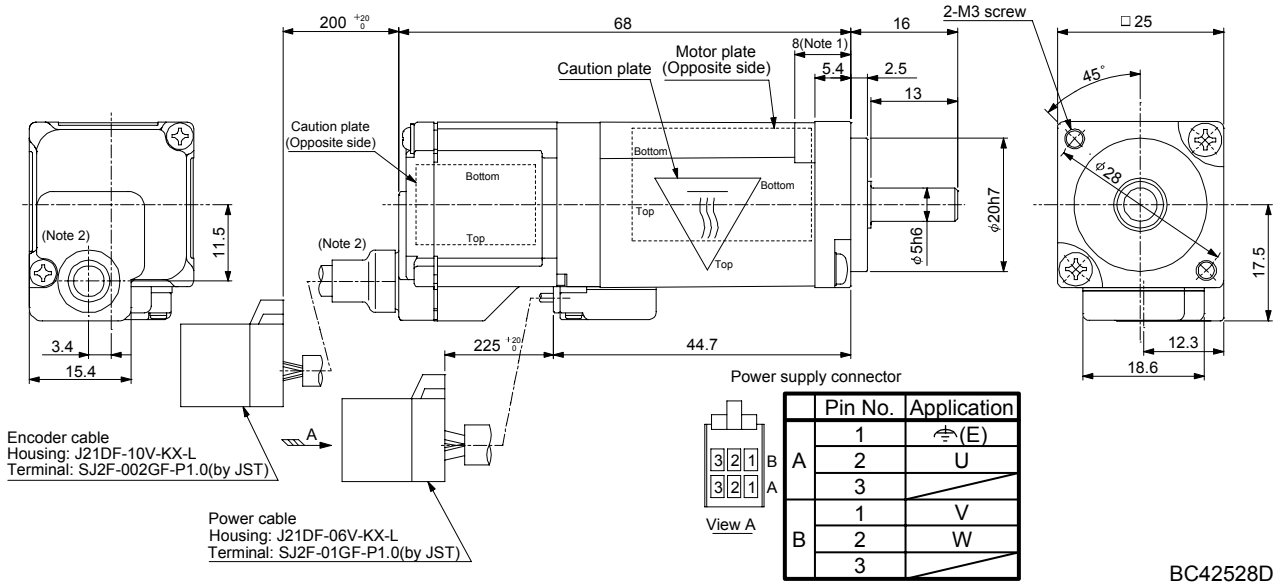

- Note 1. The length of mounting screw should be within this.
- 2. The encoder cable outlet portion change has been sequentially applied from the April 2013 production of the motors.

#### 13.6.2 With an electromagnetic brake

Model	Output [kW]	Brake static friction torque [N · m] (oz · in)	Moment of inertia J [ $\times 10^{-4}$ kg · m <sup>2</sup> ] (WK <sup>2</sup> [oz · in <sup>2</sup> ])	Mass [kg] (lb)
HG-AK0136B	10	0.095 (13.5)	0.0042 (0.023)	0.22 (0.49)

[Unit: mm]

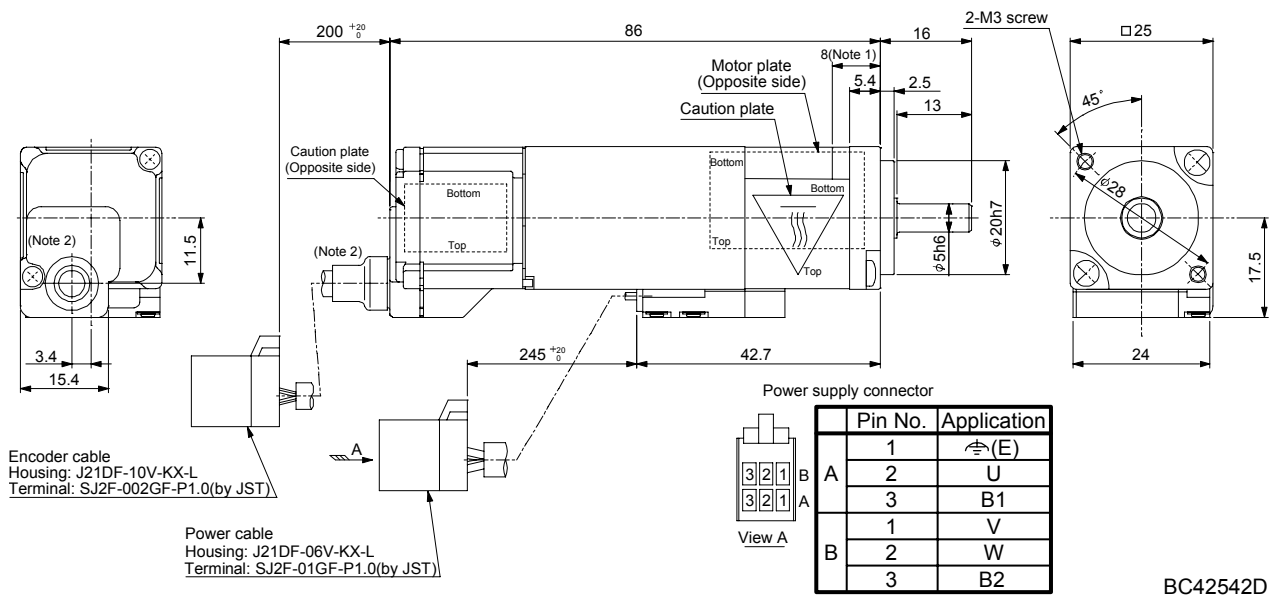

- Note 1. The length of mounting screw should be within this.
- 2. The encoder cable outlet portion change has been sequentially applied from the April 2013 production of the motors.

### 13. HG-AK SERIES

Model	Output [kW]	Brake static friction torque [N · m] (oz · in)	Moment of inertia J [ $\times 10^{-4}$ kg · m <sup>2</sup> ] (WK <sup>2</sup> [oz · in <sup>2</sup> ])	Mass [kg] (lb)
HG-AK0236B	20	0.095 (13.5)	0.0058 (0.032)	0.24 (0.53)

[Unit: mm]

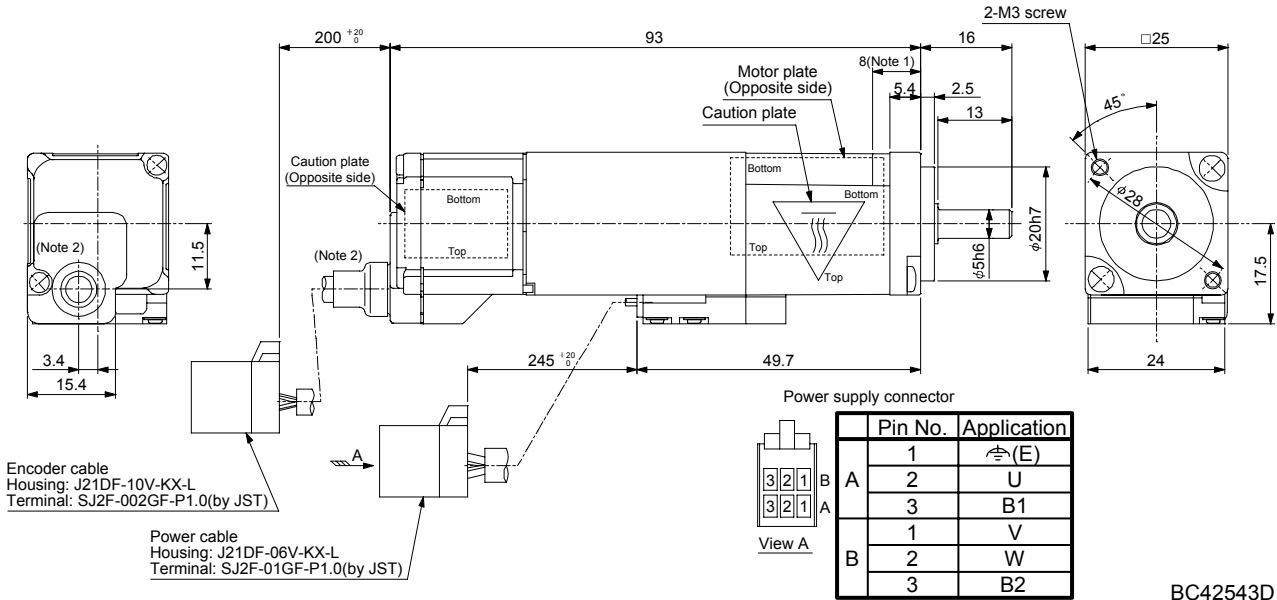

Note 1. The length of mounting screw should be within this.

2. The encoder cable outlet portion change has been sequentially applied from the April 2013 production of the motors.

Model	Output [kW]	Brake static friction torque [N · m] (oz · in)	Moment of inertia J [ $\times 10^{-4}$ kg · m <sup>2</sup> ] (WK <sup>2</sup> [oz · in <sup>2</sup> ])	Mass [kg] (lb)
HG-AK0336B	30	0.095 (13.5)	0.0074 (0.040)	0.26 (0.57)

[Unit: mm]

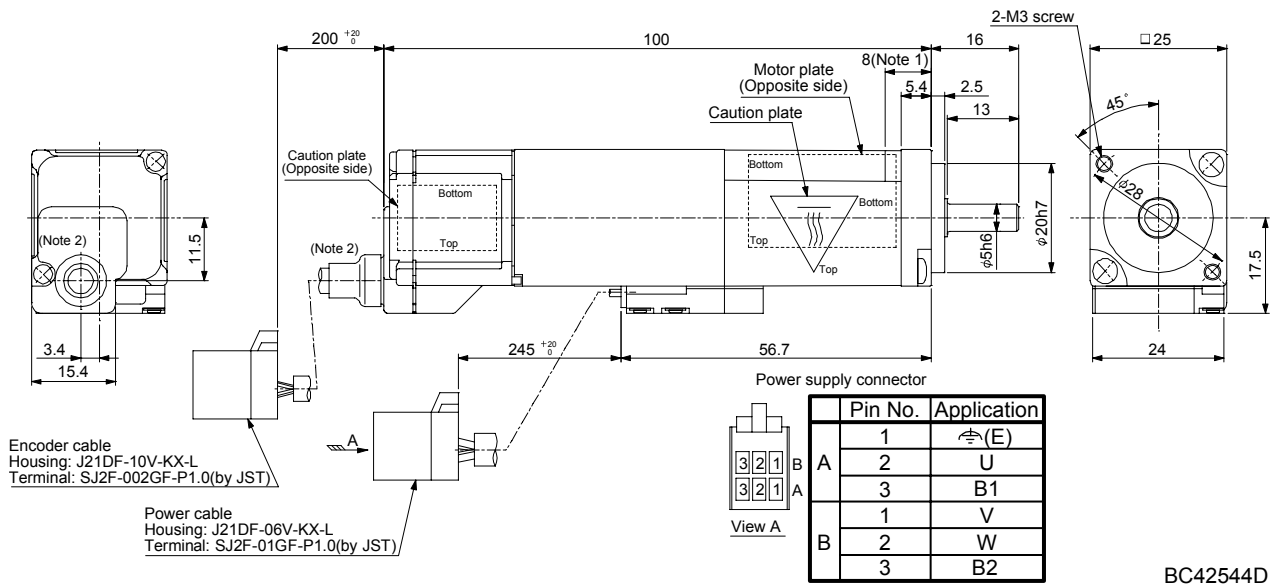

Note 1. The length of mounting screw should be within this.

2. The encoder cable outlet portion change has been sequentially applied from the April 2013 production of the motors.



# APPENDIX

## App. 1 Servo motor ID codes

Servo motor series ID	Servo motor type ID	Servo motor encoder ID	Servo motor
06	F053	0044	HF-MP053
	FF13		HF-MP13
	FF23		HF-MP23
	FF43		HF-MP43
	FF73		HF-MP73
16	F053		HF-KP053
	FF13		HF-KP13
	FF23		HF-KP23
	FF43		HF-KP43
	FF73		HF-KP73
26	FF51		HF-SP51
	FF81		HF-SP81
	F121		HF-SP121
	F201		HF-SP201
	F301		HF-SP301
	F421		HF-SP421
	FF52		HF-SP52
	F102		HF-SP102
	F152		HF-SP152
	F202		HF-SP202
	F352		HF-SP352
	F502		HF-SP502
29	F702		HF-SP702
	FF52		HF-SP524
	F102		HF-SP1024
	F152		HF-SP1524
	F202		HF-SP2024
	F352		HF-SP3524
	F502		HF-SP5024
F702	HF-SP7024		
31	FF72		HC-UP72
	F152	HC-UP152	
	F202	HC-UP202	
	F352	HC-UP352	
	F502	HC-UP502	
41	F103	HC-RP103	
	F153	HC-RP153	
	F203	HC-RP203	
	F353	HC-RP353	
51	FF52	HC-LP52	
	F102	HC-LP102	
	F152	HC-LP152	
	F202	HC-LP202	
	F302	HC-LP302	

APPENDIX

Servo motor series ID	Servo motor type ID	Servo motor encoder ID	Servo motor
53	F601	0044	HA-LP601
	F801		HA-LP801
	1201		HA-LP12K1
	1501		HA-LP15K1
	2001		HA-LP20K1
	2501		HA-LP25K1
	3001		HA-LP30K1
	3701		HA-LP37K1
	F502		HA-LP502
	F702		HA-LP702
	1102		HA-LP11K2
	1502		HA-LP15K2
	2202		HA-LP22K2
	3002		HA-LP30K2
	3702		HA-LP37K2
54	F601		HA-LP6014
	F801		HA-LP8014
	1201		HA-LP12K14
	1501		HA-LP15K14
	2001		HA-LP20K14
	1102		HA-LP11K24
	1502		HA-LP15K24
	2202		HA-LP22K24
	2501		HA-LP25K14
	3001		HA-LP30K14
	3701		HA-LP37K14
	3002		HA-LP30K24
	3702		HA-LP37K24
	4502		HA-LP45K24
	5502		HA-LP55K24
55	F701	HA-LP701M	
	1101	HA-LP11K1M	
	1501	HA-LP15K1M	
	2201	HA-LP22K1M	
	3001	HA-LP30K1M	
	3701	HA-LP37K1M	
56	F701	HA-LP701M4	
	1101	HA-LP11K1M4	
	1501	HA-LP15K1M4	
	2201	HA-LP22K1M4	
	3001	HA-LP30K1M4	
	3701	HA-LP37K1M4	
	4501	HA-LP45K1M4	
57	5001	HA-LP50K1M4	
A6	1101	HF-JP11K1M	
	1501	HF-JP15K1M	

Servo motor series ID	Servo motor type ID	Servo motor encoder ID	Servo motor
A7	FF53	0044	HF-JP53
	FF73		HF-JP73
	F103		HF-JP103
	F153		HF-JP153
	F203		HF-JP203
	F353		HF-JP353
	F503		HF-JP503
	F703		HF-JP703
	F903		HF-JP903
A8	1101		HF-JP11K1M4
	1501		HF-JP15K1M4
A9	FF53		HF-JP534
	FF73		HF-JP734
	F103		HF-JP1034
	F153		HF-JP1534
	F203		HF-JP2034
	F353		HF-JP3534
	F503		HF-JP5034
	F703		HF-JP7034
	F903		HF-JP9034
0D	F013		HG-AK0136
	F023	HG-AK0236	
	F033	HG-AK0336	

## App. 2 Compliance with the CE marking

### App. 2.1 What is CE marking?

The CE marking is mandatory and must be affixed to specific products placed on the European Union. When a product conforms to the requirements, the CE marking must be affixed to the product. The CE marking also applies to machines and equipment incorporating servos.

#### (1) EMC directive

The EMC directive applies to the servo motor alone. Therefore servo motor is designed to comply with the EMC directive. The EMC directive also applies to machines and equipment incorporating servo motors.

#### (2) Low voltage directive

The low voltage directive also applies to the servo motor alone. The servo motor is designed to comply with the low voltage directive.



## APPENDIX

### App. 2.2 For compliance

Be sure to perform an appearance inspection of every unit before installation. In addition, have a final performance inspection on the entire machine/system, and keep the inspection record.

#### (1) Wiring

Use wirings which complies with EN for the servo motor power. Complying EN products are available as options. For details, refer to the chapter of each servo motor series.

#### (2) Performing EMC tests

When EMC tests are run on a machine and device into which the servo motor and servo motor have been installed, it must conform to the electromagnetic compatibility (immunity/emission) standards after it has satisfied the operating environment and electrical equipment specifications.

For EMC directive conforming methods about converter unit, servo amplifier (drive unit) and servo motors, refer to the EMC Installation Guidelines (IB(NA)67310) and each Servo Amplifier Instruction Manual.

### App. 3 Conformance with UL/cUL standard

Use the UL/cUL Standard-compliant model of servo motor. For the latest information of compliance, contact your local sales office.

Unless otherwise specified, the handling, performance, specifications, etc. of the UL/cUL Standard-compliant models are the same as those of the standard models.

The servo motor is compliant with the UL/cUL standard when it is mounted on the flanges made of aluminum whose sizes are indicated in the following table.

The rated torque of the servo motor under the UL/cUL standard indicates the continuous permissible torque value that can be generated when it is mounted on the flange specified in this table and used in the environment of 0°C (32°F) to 40°C (104°F) ambient temperature. Therefore, to conform to the UL/cUL standard, mount the servo motor on a flange with a heat radiating effect equivalent to that of this flange.

Flange size [mm]	Servo motor							
	HF-MP · HF-KP	HF-SP	HC-RP	HC-UP	HC-LP	HA-LP	HF-JP	HG-AK
150 × 150 × 3								0136 to 0336
250 × 250 × 6	053 · 13 · 23							
250 × 250 × 12	43	51 · 81 52(4) to 152(4)	103 to 203		52 to 152		53(4) to 203(4)	
300 × 300 × 12	73							
300 × 300 × 20		121 · 201 202(4) to 352(4)			202 · 302			
550 × 550 × 30			353 · 503	72 · 152			353(4) · 503(4)	
650 × 650 × 35		301 · 421 502(4) · 702(4)		202 to 502		601(4) to 12K1(4) 701M(4) to 15K1M(4) 502 to 22K2 11K24 to 22K24	703(4) · 903(4) 11K1M(4) · 15K1M4(4)	
950 × 950 × 35						15K1(4) to 37K1(4) 22K1M to 37K1M 22K1M4 to 50K1M4 30K2 · 37K2 30K24 to 55K24		

## REVISIONS

\*The manual number is given on the bottom left of the back cover.

Print Data	*Manual Number	Revision
Oct. 2003	SH(NA)030041-A	First edition
Nov. 2004	SH(NA)030041-B	<p>Safety Instructions: Addition of the HF-SP to the environment condition table</p> <p>Section 1.1: Addition of the HF-SP to the table            Deletion of the HA-MH · HA-ME from the table            Note description change</p> <p>Section 1.2 (2): Moved to Section 6.1</p> <p>Section 1.3: Change</p> <p>Section 1.4: CAUTION change            Figure change</p> <p>Section 1.5: Insertion of item "Servo motor with reduction gear"</p> <p>Section 1.6: Moved from Section 1.5, figure addition and change</p> <p>Chapter 2: CAUTION addition</p> <p>Section 2.1 (3): Reduction gear comment addition</p> <p>Section 2.3 (1): Sentence change</p> <p>Section 2.4: Sentence change            (1) Sentence change            (2) Sentence change</p> <p>Section 2.5: Sentence change</p> <p>Section 2.6: Moved to Section 6.5</p> <p>Section 2.8: Flange size □130, 176mm addition</p> <p>Chapter 3: HF-SP addition</p> <p>Section 3.2: Figure addition</p> <p>Section 3.3: Figure addition            Partial table deletion</p> <p>Chapter 4: HF-SP connector addition</p> <p>Section 4.3: Partial figure deletion</p> <p>Section 6.1: Addition</p> <p>Section 6.2.1: Speed/position detection item description change            Note 7. sentence addition            Note description change</p> <p>Section 6.2.2: POINT addition, 100V torque characteristic addition</p> <p>Section 6.3: CAUTION addition</p> <p>Section 6.5: CAUTION change</p> <p>Section 6.5.1 (2): Specification item change</p> <p>Section 6.5.2 (2): Specification item change</p> <p>Section 6.6 to 6.8: Addition of outline drawings of servo motors with reduction gears</p> <p>Chapter 7: Addition</p> <p>Section 7.6.1: Partial dimension change</p> <p>Section 7.7.1: Partial dimension change</p> <p>Appendices: HF-SP ID code addition            Memo page deletion</p>
Mar. 2005	SH(NA)030041-C	<p>Compliance with EC directives :Make the HF-MP, H-SP502, 702 to the standard conformance.</p> <p>UL / C-UL Standard :Make the HF-MP, H-SP502, 702 to standard conformance.</p> <p>For maximum safety :Sentence addition</p>

Print Data	*Manual Number	Revision
Mar. 2005	SH(NA)030041-C	<p>Section 6.8 :Partial outline dimension drawings</p> <p>HF-MP43, HF-MP73, MF-MP13B, HF-MP73BG1(1/5)  HF-MP13G5(1/33, 1/45), HF-MP43G5(1/33, 1/45)  HF-MP13BG5(1/33, 1/45), HF-MP43BG5(1/33, 1/45)  HF-MP053G7(1/5, 1/11, 1/21, 1/33, 1/45), HF-MP13G7(1/33, 1/45),  HF-MP23G7(1/21, 1/33, 1/45), HF-MP43G7(1/33, 1/45)  HF-MP13BG7(1/33, 1/45), HF-MP43BG7(1/33, 1/45)  HF-KP43, HF-KP73, MF-KP13B, HF-KP73BG1(1/5)  HF-KP13G5(1/33, 1/45), HF-KP43G5(1/33, 1/45)  HF-KP13BG5(1/33, 1/45), HF-KP43BG5(1/33, 1/45)  HF-KP053G7(1/5, 1/11, 1/21, 1/33, 1/45)  HF-KP13G7(1/33, 1/45), HF-KP23G7(1/21, 1/33, 1/45)  HF-KP43G7(1/33, 1/45), HF-KP13BG7(1/33, 1/45)  HF-KP43BG7(1/33, 1/45)</p> <p>Section 7.6 :Partial outline dimension drawings</p> <p>HF-SP51/102, HF-SP81/152, HF-SP121/202  HF-SP201/352  HF-SP51B/102B, HF-SP81B/152B, HF-SP121B/202B  HF-SP201B/352B</p>
Dec. 2005	SH(NA)030041-D	<p>Safety Instructions 4: (1) Transportation and installation Error correction of sentences  Partial addition of table  (4) Wiring Addition of sentences</p> <p>About processing of waste: Change of text from "PRECAUTIONS FOR CHOOSING THE PRODUCTS"  UL/C-UL standard: Addition of table</p> <p>Section 1.3: Addition of motor figure  Section 2.1 (1): Description addition of cooling fan  Section 2.8: Addition of table  Section 2.9: Partial addition of table  Section 3.1 (3): Addition of HA-LP series figure/table  (4): Addition of HC-RP series figure/table  (5): Addition of HC-UP series figure/table  (6): Addition of HC-LP series figure/table  Section 3.4: Addition of connector configuration J, K, L  Chapter 4: Addition of connector outline drawings  Error correction  Section 6.1: Error correction  Section 6.2.1: Correction of HF-KP series load inertia moment ratio  Section 6.2.2: Change of HF-MP and HF-KP torque characteristics  Section 6.3: Addition of Note sentences  Section 6.5.1 (2): Partial change of table: Reexamination of Note 3 sentence  Section 6.5.2 (2): Partial change of table: Reexamination of Note 3 sentence  Section 6.5.2 (3) :Partial change of table  Section 6.5.3: Addition of HF-MP and HF-KP wiring option  Section 6.8: Deletion of section  Section 7.1: Addition of new models HP-SP301 and HP-SP421 to table</p>

Print Data	*Manual Number	Revision
Dec. 2005	SH(NA)030041-D	Section 7.2.1 :Addition of new model to table Addition of Note to table Addition of Note 9 and 10 Section 7.2.2 :Addition of new model Change of HF-SP52 torque characteristics Section 7.3 :Addition of Note sentences Addition of new model to table Section 7.4 :Addition of new model to table Section 7.5 :Addition of HF-SP G1(H), G5, G7 Section 7.6 :Addition of new model to table Section 7.7.1-7.7.2 :Error correction Addition of new model outline drawings Section 7.7.3-7.7.10 :Addition of G1(H), G5, G7 outline drawings Section 7.7.10 :Error correction Chapter 8 :Addition of Chapter on HA-LP series Chapter 9 :Addition of Chapter on HC-RP series Chapter 10 :Addition of Chapter on HC-UP series Chapter 11 :Addition of Chapter on HC-LP series Appendix Appendix.1 :Addition of new model servo motor ID code
Aug. 2007	SH(NA)030041-E	Addition of servo motors HF-SP524/1024/1524/2024/3524 Addition of HA-LP6014, 12K14, 701M4, 15K1M4, and 22K1M4 Addition of WARNING about charge lamp off confirmation to corresponding section Addition of WARNING about attaching magnetic contactor to corresponding section Change of "servo amplifier" to "converter unit and servo amplifier (drive unit)" Safety Instructions 2: To prevent fire: Sentence change Safety Instructions 4: (1) Transportation and installation Partial addition of table (2) Wiring Correction of figure Compliance with EC directives: 2. Precautions for compliance (2) Addition UL/C-UL Standard: Change of table contents Section 1.1: Partial correction of table Change of Note 1 and 6, and addition of Note 9 and 10 Section 2.1 (1): Correction of table sentences Section 2.7: Addition of servo motor with oil seal Section 3.1(2) (3): Partial addition of table Section 6.5.2 (3): Correction of the table Section 7.1: Table addition Section 7.2.1: Table addition Change of Note 1, 2, and 5 Section 7.2.2: Graph addition Section 7.3: Partial correction of table Section 7.4: Partial correction of table Section 7.5: Addition of servo motor with oil seal Section 7.6.1 (2): Partial addition of table Note addition (2) (b): Partial correction of table Section 7.6.2: Partial addition of table Section 7.8: Addition of outline dimension drawings Section 8.1: Partial addition of table

Print Data	*Manual Number	Revision
Aug. 2007	SH(NA)030041-E	<p>Section 8.2: Correction of values for maximum current, rated current and Current value and power supply voltage of cooling fan</p> <p>Table addition</p> <p>Section 8.2.1: Addition of HA-LP6014, 12K14, 701M4, 15K1M4, and 22K1M4 to standard specifications</p> <p>Change of Note 1, 2, and 5</p> <p>Addition of Note 9</p> <p>Section 8.2.2: Graph addition</p> <p>Section 8.3: Partial addition of table</p> <p>Section 8.4: Partial addition of table</p> <p>Section 8.6: Partial addition of table</p> <p>Section 8.7: Addition of outline dimension drawings</p> <p>Section 9.1: Table addition</p> <p>Note addition</p> <p>Section 9.2.1: Note addition</p> <p>Section 9.5: Addition</p> <p>Section 9.7: Addition of outline dimension drawings</p> <p>Appendix. 1: Partial addition of table</p>
Feb. 2008	SH(NA)030041-F	<p>Change of description from "misoperation" to "unexpected operation"</p> <p>Section 7.8: Change of outline dimension drawings for HF-SP201, 301, 352(4), and 502(4) because of hanging bolt location change</p> <p>Section 8.7: Change of outline dimension drawings for HA-LP15K1(4), 20K1(4), 25K1(4), 30K1(4), 37K1(4), 22K1M(4), 30K1M(4), 37K1M(4), 45K1M(4), 50K1M4, 30K2(4), 37K2(4), 45K2(4), and 55K24 because of notch addition</p> <p>Change of terminal box for HA-LP801(4), 12K1(4), 11K1M(4), 15K1M(4), 15K2(4) and 22K2(4)</p>
Feb. 2009	SH(NA)030041-G	<p>Change of all (JIS C0617 compliant) graphical symbols for use in electrotechnical diagram</p> <p>Safety Instructions</p> <p>Section 1.1: Change of items in Compliance with Overseas Standards for HA-LP</p> <p>Change of HC-LP servo motor IP rating to IP65</p> <p>Deletion of Note 10</p> <p>Chapter 2: Addition of WARNING</p> <p>Addition of CAUTION sentences</p> <p>Chapter 3: Addition of POINT sentences describing protective structure</p> <p>Section 3.3: Partial change in appearance drawings and model names of wiring connectors</p> <p>Chapter 4 (3): Change in model names and outline drawings of connectors</p> <p>Section 5.9: Partial change of calculation results in selection example</p> <p>Section 6.1: Change of rating output value to kW</p> <p>Section 7.7: Change in model names of connectors</p> <p>Section 8.2.1: Change of model name of large capacity servo amplifier to DU□K</p> <p>Section 9.4: Partial change of variable dimensions for HC-RP353K to 503K</p> <p>Section 10.4: Partial change of variable dimensions for HC-UP152K</p>
Oct. 2010	SH(NA)030041-H	<p>HF-JP servo motor addition, change of "EN standard" to "IEC/EN standard"</p> <p>2. To prevent fire, note Item addition</p> <p>the following</p>

Print Data	*Manual Number	Revision		
Oct. 2010	SH(NA)030041-H	4.(1) Transportation and installation 4.(2) Wiring 4.(5) Corrective actions DISPOSAL OF WASTE COMPLIANCE WITH EC DIRECTIVES CONFORMANCE WITH UL/C-UL STANDARD Section 1.1 Section 1.2 Section 1.4 Section 1.4 (1) Section 1.4 (3) Chapter 2 Section 2.1 (1) Section 2.9 (b) Section 2.10 Chapter 3 Section 3.1 (1) Section 3.1 (7) Section 3.3 Section 3.4  Chapter 4 (3) Section 5.5 (3) Section 6.2.1 Section 6.2.2  Section 6.3  Section 7.2.1 Section 7.3  Section 8.3  Section 9.3  Section 10.3  Section 11.3  Chapter 12	Item change, item addition  Two items change Item change Title change, description change Content move to APPENDIX Content move to APPENDIX  HF-JP series addition, Note 10 addition Note addition, Rating plate change CAUTION change Description change New addition of (3) CAUTION addition HF-JP series addition Title is addition Reference diagram change POINT change HF-MP series addition in the table New addition of (7) Change of connector configuration D and F Change of diagram of connector configuration J, connector addition, addition of connector configuration M and N Addition of (b), (i) and (j), addition of table (f) and (g) Description change Note 11 addition Change of torque characteristics diagram of HF-KP series Change of three items in the table, addition of Note 6 to 8 Note 11 addition Change of three items in the table, addition of Note 6 to 8 Change of three items in the table, addition of Note 6 to 8 Change of three items in the table, addition of Note 6 to 8 Change of three items in the table, addition of Note 6 to 8 Change of three items in the table, addition of Note 6 to 8 Change of three items in the table, addition of Note 6 to 8 New addition as Chapter 12	
Nov. 2012	SH(NA)030041-J	Addition of servo motors HF-JP703(4)/HF-JP903(4)/HG-AK series Safety Instructions 1 Safety Instructions 2 Safety Instructions 3  Safety Instructions 4 (1)  Safety Instructions 4 (2)	HF-JP703(4)/HF-JP903(4)/HG-AK series The sentences are added. The sentences are partially deleted. The sentences are changed. The sentences are added. The sentences are changed. The sentences are added. The part of table is changed. The sentences are changed.	

Print Data	*Manual Number	Revision	
Nov. 2012	SH(NA)030041-J	Safety Instructions 4 (4) Safety Instructions 4 (5) Safety Instructions 4 (6) COMPLIANCE WITH CE MARKING Section 1.1 Section 1.2 Section 1.3 Section 1.4 Section 1.4 (1) Section 1.4 (2) Section 1.4 (3) Section 1.5 Chapter 2 Section 2.1 Section 2.4 Section 2.8 Section 2.9 Section 3.1 Section 3.2 Section 3.3 Section 3.4 Section 3.5 Chapter 4 Section 5.5 (3) Section 6.2.1 Section 6.2.2 Section 6.3 Section 6.8 Section 7.2.2 Section 7.3 Section 8.2.1 Section 8.3 Section 8.4 Section 8.8 Section 9.3 Section 9.7.4 Section 9.7.6 Section 9.8	The sentences are changed. The sentences are added. The sentences are changed. The sentences are changed. Title is changed. The part of table is changed. Note 10 is changed. The diagram is changed. The diagram is added. The sentences are changed to CAUTION. The sentences are added to CAUTION. The sentences are changed. The sentences are added. The sentences are added. The sentences are changed. The diagram is changed. The sentences are changed to CAUTION. The part of table is changed. The sentences are changed to CAUTION. The sentences are changed to CAUTION. The table is changed. The table is changed. The part of table is changed. The table is added. The part of table is changed. The part of table is changed. Addition The part of diagram is changed. POINT is added. The sentences of Note 11 are changed. The sentences are changed. The part of diagram is changed. The sentences are added to CAUTION. The sentences are changed. The sentences are changed. The part of diagram is changed. The sentences are added to CAUTION. The part of table is changed. The sentences are added to CAUTION. The part of diagram is changed. Addition The sentences are added to CAUTION. The part of diagram is changed. The part of diagram is changed. Addition

Print Data	*Manual Number	Revision	
Nov. 2012	SH(NA)030041-J	Section 10.2.2	The sentences are changed.
		Section 10.3	The sentences are added to CAUTION.
		Section 10.7	Addition
		Section 11.2.2	The sentences are changed.
		Section 11.3	The sentences are added to CAUTION.
		Section 11.7	Addition
		Section 12.1	The part of table is changed.
		Section 12.2.1	The part of table is changed.
		Section 12.2.2	The sentences are changed.
			The part of diagram is changed.
		Section 12.3	The sentences are added to CAUTION.
			The part of table is changed.
		Section 12.4	The part of table is changed.
		Section 12.5	The part of table is changed.
		Section 12.6	The diagram is added.
		Section 12.7	Addition
		Chapter 13	Addition
		Appendix 1	The part of table is changed.
		Appendix 2	The sentences are changed.
		Appendix 3	The part of table is changed.
Apr. 2013	SH(NA)030041-K	Section 3.1 (8)	The part of diagram is changed.
		Section 5.9 (8) to (10)	Some numbers are changed.
		Section 13.6	The part of diagram is changed.

This manual confers no industrial property rights or any rights of any other kind, nor does it confer any patent licenses. Mitsubishi Electric Corporation cannot be held responsible for any problems involving industrial property rights which may occur as a result of using the contents noted in this manual.



Country/Region	Sales office	Tel/Fax
USA	Mitsubishi Electric Automation Inc. 500 Corporate Woods Parkway, Vernon Hills, IL 60061, USA	Tel : +1-847-478-2100 Fax : +1-847-478-0327
Germany	Mitsubishi Electric Europe B.V. German Branch Gothaer Strasse 8, D-40880 Ratingen, Germany	Tel : +49-2102-486-0 Fax : +49-2102-486-1120
Italy	Mitsubishi Electric Europe B.V. Italian Branch Viale Colleoni 7 1-20041 Agrate Brianza (Milano), Italy	Tel : +39-39-60531 Fax : +39-39-6053312
China	Mitsubishi Electric Automation (China) Ltd. 4F Zhi Fu Plazz, No. 80 Xin Chang Road Shanghai 200003, China	Tel : +86-21-6120-0808 Fax : +86-21-6121-2444
Taiwan	Setsuyo Enterprise Co., Ltd. 6F, No.105 Wu-Kung 3rd Rd, Wu-Ku Hsiang, Taipei Hsine, Taiwan	Tel : +886-2-2299-2499 Fax : +886-2-2299-2509
Korea	Mitsubishi Electric Automation Korea Co., Ltd. 3F, 1480-6, Gayang-dong, Gangseo-gu, Seoul 157-200, Korea	Tel : +82-2-3660-9552 Fax : +82-2-3664-8372
Singapore	Mitsubishi Electric Asia Pte, Ltd. 307 Alexandra Road #05-01/02, Mitsubishi Electric Building Singapore 159943	Tel : +65-6470-2460 Fax : +65-6476-7439

## Warranty

### 1. Warranty period and coverage

We will repair any failure or defect hereinafter referred to as "failure" in our FA equipment hereinafter referred to as the "Product" arisen during warranty period at no charge due to causes for which we are responsible through the distributor from which you purchased the Product or our service provider. However, we will charge the actual cost of dispatching our engineer for an on-site repair work on request by customer in Japan or overseas countries. We are not responsible for any on-site readjustment and/or trial run that may be required after a defective unit are repaired or replaced.

### [Term]

The term of warranty for Product is twelve (12) months after your purchase or delivery of the Product to a place designated by you or eighteen (18) months from the date of manufacture whichever comes first ("Warranty Period"). Warranty period for repaired Product cannot exceed beyond the original warranty period before any repair work.

### [Limitations]

- (1) You are requested to conduct an initial failure diagnosis by yourself, as a general rule.  
It can also be carried out by us or our service company upon your request and the actual cost will be charged. However, it will not be charged if we are responsible for the cause of the failure.
- (2) This limited warranty applies only when the condition, method, environment, etc. of use are in compliance with the terms and conditions and instructions that are set forth in the instruction manual and user manual for the Product and the caution label affixed to the Product.
- (3) Even during the term of warranty, the repair cost will be charged on you in the following cases;
  - (i) a failure caused by your improper storing or handling, carelessness or negligence, etc., and a failure caused by your hardware or software problem
  - (ii) a failure caused by any alteration, etc. to the Product made on your side without our approval
  - (iii) a failure which may be regarded as avoidable, if your equipment in which the Product is incorporated is equipped with a safety device required by applicable laws and has any function or structure considered to be indispensable according to a common sense in the industry
  - (iv) a failure which may be regarded as avoidable if consumable parts designated in the instruction manual, etc. are duly maintained and replaced
  - (v) any replacement of consumable parts (battery, fan, smoothing capacitor, etc.)
  - (vi) a failure caused by external factors such as inevitable accidents, including without limitation fire and abnormal fluctuation of voltage, and acts of God, including without limitation earthquake, lightning and natural disasters
  - (vii) a failure generated by an unforeseeable cause with a scientific technology that was not available at the time of the shipment of the Product from our company
  - (viii) any other failures which we are not responsible for or which you acknowledge we are not responsible for

### 2. Term of warranty after the stop of production

- (1) We may accept the repair at charge for another seven (7) years after the production of the product is discontinued. The announcement of the stop of production for each model can be seen in our Sales and Service, etc.
- (2) Please note that the Product (including its spare parts) cannot be ordered after its stop of production.

### 3. Service in overseas countries

Our regional FA Center in overseas countries will accept the repair work of the Product. However, the terms and conditions of the repair work may differ depending on each FA Center. Please ask your local FA center for details.

### 4. Exclusion of responsibility for compensation against loss of opportunity, secondary loss, etc.

Whether under or after the term of warranty, we assume no responsibility for any damages arisen from causes for which we are not responsible, any losses of opportunity and/or profit incurred by you due to a failure of the Product, any damages, secondary damages or compensation for accidents arisen under a specific circumstance that are foreseen or unforeseen by our company, any damages to products other than the Product, and also compensation for any replacement work, readjustment, start-up test run of local machines and the Product and any other operations conducted by you.

### 5. Change of Product specifications

Specifications listed in our catalogs, manuals or technical documents may be changed without notice.

### 6. Application and use of the Product

- (1) For the use of our General-Purpose AC Servo, its applications should be those that may not result in a serious damage even if any failure or malfunction occurs in General-Purpose AC Servo, and a backup or fail-safe function should operate on an external system to General-Purpose AC Servo when any failure or malfunction occurs.
- (2) Our General-Purpose AC Servo is designed and manufactured as a general purpose product for use at general industries. Therefore, applications substantially influential on the public interest for such as atomic power plants and other power plants of electric power companies, and also which require a special quality assurance system, including applications for railway companies and government or public offices are not recommended, and we assume no responsibility for any failure caused by these applications when used.  
In addition, applications which may be substantially influential to human lives or properties for such as airlines, medical treatments, railway service, incineration and fuel systems, man-operated material handling equipment, entertainment machines, safety machines, etc. are not recommended, and we assume no responsibility for any failure caused by these applications when used.  
We will review the acceptability of the abovementioned applications, if you agree not to require a specific quality for a specific application. Please contact us for consultation.



MODEL	MOTOR INSTRUCTION(VOL.2)
MODEL CODE	1CW951

# MITSUBISHI ELECTRIC CORPORATION

HEAD OFFICE : TOKYO BLDG MARUNOUCHI TOKYO 100-8310