

# **MELSERVO**

## Servo Motors and Servo Amplifiers Specifications and Installation Guide

### **MR-J2-A**

Thank you for choosing this Mitsubishi AC servo. This Installation guide gives handling information and precautions for using the servo amplifier and servo motor. Incorrect handling may cause an unexpected fault. Before using the servo amplifier and servo motor, please read this Installation guide carefully to use the equipment to its optimum.  
Please forward this Installation guide to the end user.

### Safety Instructions

Do not attempt to install, operate, maintain or inspect the servo amplifier and servo motor until you have read through this Installation guide and appended documents carefully and can use the equipment correctly. Do not use the servo amplifier and servo motor until you have a full knowledge of the equipment, safety information and instructions.  
In this Installation guide, the safety instruction levels are classified into "WARNING" and "CAUTION".



Indicates that incorrect handling may cause hazardous conditions,, resulting in death or severe injury.





Indicates that incorrect handling may cause hazardous conditions,, resulting in medium or slight injury to personnel or may cause physical damage.

Note that the CAUTION level may lead to a serious consequence according to conditions. Please follow the instructions of both levels because they are important to personnel safety.

What must not be done and what must be done are indicated by the following diagrammatic symbols:

 : Indicates what must not be done. For example, "No Fire" is indicated by .

 : Indicates what must be done. For example, grounding is indicated by .

After reading this installation guide, always keep it accessible to the operator.

In this Installation guide, instructions at a lower level than the above, instructions for other functions, and so on are classified into "NOTICE", "INFORMATION" and "MEMORANDUM".

**NOTICE** Indicates that incorrect handling may cause the servo amplifier to be faulty and may not lead to physical damage.

**INFORMATION** Indicates that parameter setting change, etc. will provide another function or there are other usages.

**MEMORANDUM** Indicates information needed for use of this equipment.







---

## **SAFETY INSTRUCTIONS**

---




### **1. To prevent electric shock, note the following:**

#### **WARNING**

-  Before wiring or inspection, switch power off and wait for more than 10 minutes. Then, confirm the voltage is safe with voltage tester. Otherwise, you may get an electric shock.
-  Connect the servo amplifier and servo motor to ground.
-  Any person who is involved in wiring and inspection should be fully competent to do the work.
-  Do not attempt to wire the servo amplifier and servo motor until they have been installed. Otherwise, you may get an electric shock.
-  Operate the switches with dry hand to prevent an electric shock.
-  The cables should not be damaged, stressed loaded,, or pinched. Otherwise, you may get an electric shock.





### **2. To prevent fire, note the following:**

#### **CAUTION**

-  Do not install the servo amplifier, servo motor and regenerative brake resistor on or near combustibles. Otherwise a fire may cause.
-  When the servo amplifier has become faulty, switch off the main servo amplifier power side. Continuous flow of a large current may cause a fire.
-  When a regenerative brake resistor is used, use an alarm signal to switch main power off. Otherwise, a regenerative brake transistor fault or the like may overheat the regenerative brake resistor, causing a fire.

### **3. To prevent injury, note the following:**

#### **CAUTION**












-  Only the voltage specified in the Installation guide should be applied to each terminal,, Otherwise,, a burst,, damage,, etc. may occur.
-  Connect the terminals correctly to prevent a burst,, damage,, etc.
-  Ensure that polarity (+, -) is correct. Otherwise, a burst, damage, etc. may occur.
-  During power-on or for some time after power-off, do not touch the servo amplifier fins, regenerative brake resistor, servo motor, etc. Their temperatures may be high and you may get burnt.

#### 4. Additional instructions

The following instructions should also be fully noted. Incorrect handling may cause a fault, injury, electric shock, etc.

##### (1) Transportation and installation

### CAUTION

-  Transport the products correctly according to their weights.
-  Stacking in excess of the specified number of products is not allowed.
-  Do not carry the motor by the cables, shaft or encoder.
-  Do not hold the front cover to transport the controller. The controller may drop.
-  Install the servo amplifier in a load-bearing place in accordance with the Installation guide.
-  Do not climb or stand on servo equipment. Do not put heavy objects on equipment.
-  The controller and servo motor must be installed in the specified direction.
-  Leave specified clearances between the servo amplifier and control enclosure walls or other equipment.
-  Do not install or operate the servo amplifier and servo motor which has been damaged or has any parts missing.
-  Provide adequate protection to prevent screws and other conductive matter, oil and other combustible matter from entering the servo amplifier.
-  Do not drop or strike servo amplifier or servo motor. Isolate from all impact loads.

## ⚠ CAUTION

⚠ Use the servo amplifier and servo motor under the following environmental conditions:

Environmen		Conditions		
		Servo Amplifier	Servo Motor	
Ambient temperature	[°C]	0 to +55 (non-freezing)	0 to +40 (non-freezing)	
	[°F]	32 to 131 (non-freezing)	32 to 104 (non-freezing)	
Ambient humidity		90%RH or less (non-condensing)	80%RH or less (non-condensing)	
Storage temperature	[°C]	-20 to +65 (non-freezing)	-15 to +70 (non-freezing)	
	[°F]	-4 to 149 (non-freezing)	5 to 158 (non-freezing)	
Storage humidity		90%RH or less (non-condensing)		
Ambience		Indoors (no direct sunlight) Free from corrosive gas, flammable gas, oil mist, dust and dirt		
Altitude		Max. 1000m (3280 ft) above sea level		
Vibration	[m/s <sup>2</sup> ]	5.9 (0.6G) or less	MC-MF series HA-FF series HU-UF13 to 43	X • Y: 19.6
			HC-SF81 HC-SF52 to 152 HC-SF53 to 153 HC-RF series HC-UF72 • 152	X: 9.8 Y: 24.5
			HC-SF121 • 201 HC-SF202 • 352 HC-SF203 • 353 HC-UF202	X: 19.6 Y: 49
			HC-SF301	X: 11.7 Y: 29.4
	[ft/s <sup>2</sup> ]	19.4 or less	MC-MF series HA-FF series HU-UF13 to 43	X • Y: 64
			HC-SF81 HC-SF52 to 152 HC-SF53 to 153 HC-RF series HC-UF72 • 152	X: 32 Y: 80
			HC-SF121 • 201 HC-SF202 • 352 HC-SF203 • 353 HC-UF202	X: 64 Y: 161
			HC-SF301	X: 39 Y: 96

⚠ Securely attach the servo motor to the machine. If attach insecurely, the servo motor may come off during operation.

⚠ The servo motor with reduction gear must be installed in the specified direction to prevent oil leakage.

⚠ For safety of personnel, always cover rotating and moving parts.

⚠ Never hit the servo motor or shaft, especially when coupling the servo motor to the machine. The encoder may become faulty.

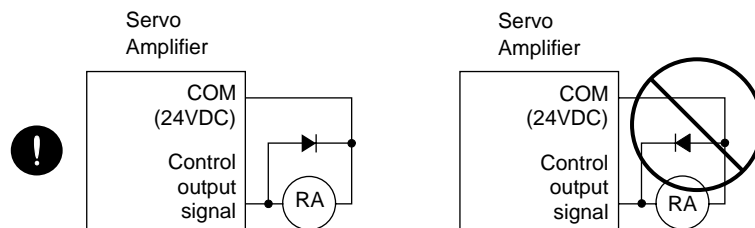
⚠ Do not subject the servo motor shaft to more than the permissible load. Otherwise, the shaft may break.

❗ When the equipment has been stored for an extended period of time, consult Mitsubishi.

## (2) Wiring

### ⚠ CAUTION

- ⚠ Wire the equipment correctly and securely. Otherwise, the servo motor may misoperate
- ⚠ Do not install a power capacitor, surge absorber or radio noise filter (FR-BIF option) between the servo motor and servo amplifier.
- ⚠ Connect the output terminals (U, V, W) correctly. Otherwise, the servo motor will operate improperly.
- ⚠ Do not connect AC power directly to the servo motor. Otherwise, a fault may occur.
- ⚠ The surge absorbing diode installed on the DC output signal relay must be wired in the specified direction. Otherwise, the emergency stop and other protective circuits may not operate.



## (3) Test run adjustment

### ⚠ CAUTION

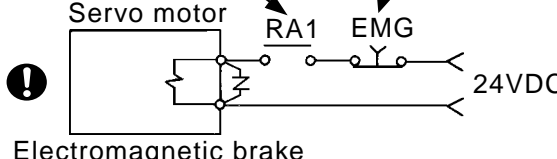
- ⚠ Before operation, check the parameter settings. Improper settings may cause some machines to perform unexpected operation.
- ⚠ The parameter settings must not be changed excessively. Operation will be instable.

## (4) Usage

### ⚠ CAUTION

- ❗ Provide an external emergency stop circuit to ensure that operation can be stopped and power switched off immediately.
- ⊘ Any person who is involved in disassembly and repair should be fully competent to do the work.
- ⚠ Before resetting an alarm, make sure that the run signal is off to prevent an accident. A sudden restart is made if an alarm is reset with the run signal on.
- ⚠ Do not modify the equipment.
- ⚠ Use a noise filter, etc. to minimize the influence of electromagnetic interference, which may be caused by electronic equipment used near the servo amplifier.
- ⚠ Use the servo amplifier with the specified servo motor.
- ⊘ The electromagnetic brake on the servo motor is designed to hold the motor shaft and should not be used for ordinary braking.
- ⚠ For such reasons as service life and mechanical structure (e.g. where a ballscrew and the servo motor are coupled via a timing belt), the electromagnetic brake may not hold the motor shaft. To ensure safety, install a stopper on the machine side

(5) Corrective actions

<b>⚠ CAUTION</b>	
<p>⚠ When it is assumed that a hazardous condition may take place at the occur due to a power failure or a product fault,, use a servo motor with electromag&lt;-&gt;netic brake or an external brake mechanism for the purpose of prevention.</p> <p>⚠ Configure the electromagnetic brake circuit so that it is activated not only by the servo amplifier signals but also by an external emergency stop signal.</p>	<p>Contacts must be open when servo is off or when an alarm (trouble) is present.</p> <p>Circuit must be opened during emergency stop.</p>  <p>Servo motor</p> <p>RA1</p> <p>EMG</p> <p>24VDC</p> <p>Electromagnetic brake</p>
<p>⚠ When any alarm has occurred,, eliminate its cause,, ensure safety,, then reset the alarm,, before restarting operation.</p> <p>⚠ When power is restored after an instantaneous power failure,, keep away from the machine because the machine may be restarted suddenly (design the machine so that it is secured against hazard if restarted).</p>	

(6) Maintenance, inspection and parts replacement

<b>⚠ CAUTION</b>	
<p>⚠ With age, the electrolytic capacitor will deteriorate. To prevent a secondary accident due to a fault, it is recommended to replace the electrolytic capacitor every 10 years when used in general environment. Please consult our sales representative.</p>	

(7) Disposal

<b>⚠ CAUTION</b>	
<p>⚠ Dispose of the product as general industrial waste.</p>	

(8) General instruction

<p>To illustrate details, the equipment in the diagrams of this Installation guide may have been drawn without covers and safety guards. When the equipment is operated, the covers and safety guards must be installed as specified. Operation must be performed in accordance with this Installation guide.</p>
---

# COMPLIANCE WITH EC DIRECTIVES

## 1. WHAT ARE EC DIRECTIVES?

The EC Directives were issued to standardize the regulations of the EU countries and ensure smooth distribution of safety-guaranteed products. In the EU countries, the Machinery Directive (effective in January, 1995), EMC Directive (effective in January, 1996) and Low Voltage Directive (effective in January, 1997) of the EC Directives require that products to be sold should meet their fundamental safety requirements and carry the CE marks (CE marking). CE marking applies to machines and equipment into which servo amplifiers have been installed.

### (1) EMC directive

The EMC directive applies to a machine/equipment which incorporates the servo, not to the servo alone. Hence, the EMC filter must be used to make this machine/equipment which incorporates the servo comply with the EMC Directive. For specific methods to comply with the EMC Directive, refer to the "EMC Installation Guidelines" (IB(NA)67310).

This servo has been approved by TUV, third-party evaluation organization, which confirmed that it can comply with the EMC Directive in the methods given in the "EMC Installation Guidelines".

### (2) Low voltage directive

The low voltage directive applies also to the servo alone. Therefore, our servo is designed to comply with the Low Voltage Directive.

This servo has been approved by TUV, third-party evaluation organization, which confirmed that it complies with the Low Voltage Directive.

### (3) Machinery directive

Since the servo amplifiers are not machines, they need not comply with this directive.

## 2. PRECAUTIONS FOR COMPLIANCE

### (1) Servo amplifiers and servo motors used

Use the following models of servo amplifiers and servo motors:

Servo amplifier series: MR-J2-10A to MR-J2-350A

Servo motor series : HC-KF -UE

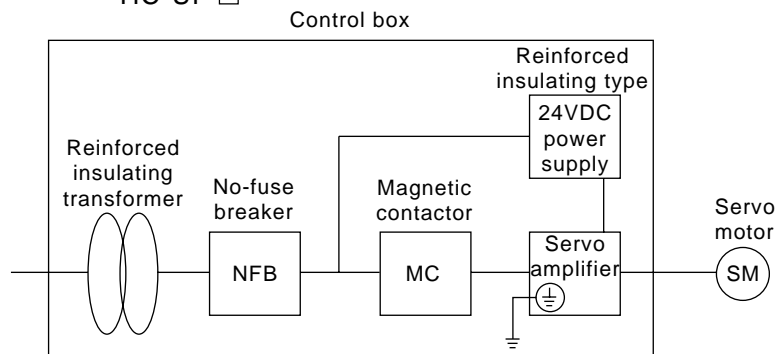
HC-MF -UE

HC-SF

HC-RF

HC-UF

### (2) Structure



### (3) Environment

Operate the servo amplifier at or above the contamination level 2 set forth in IEC664. For this purpose, install the servo amplifier in a control box which is protected against water, oil, carbon, dust, dirt, etc. (IP54).

### (4) Power supply

1) Operate the servo amplifier to meet the requirements of the overvoltage category II set forth in IEC664. For this purpose, a reinforced insulating transformer conforming to the IEC or EN Standard should be used in the power input section.

2) When supplying interface power from external, use a 24VDC power supply which has been insulation-reinforced in I/O.



(5) Grounding

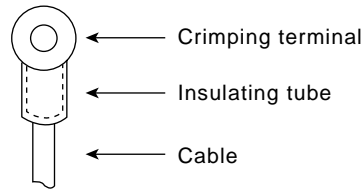
- 1) To prevent an electric shock, always connect the protective earth (PE) terminals (marked ⊕) of the servo amplifier to the protective earth (PE) of the control box.
- 2) Do not connect two ground cables to the same protective earth (PE) terminal as shown at right below. Always connect the cables to the terminals one-to-one.



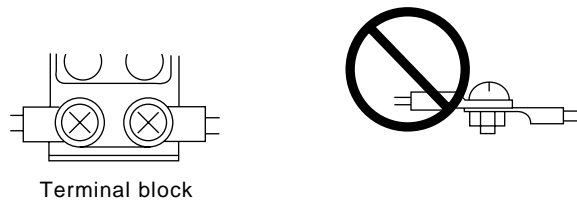
- 3) If a leakage current breaker is used to prevent an electric shock, the protective earth (PE) terminals of the servo amplifier must be connected to the corresponding earth terminals.

(6) Wiring

- 1) The cables to be connected to the terminal block of the servo amplifier must have crimping terminals provided with insulating tubes to prevent contact with adjacent terminals.



- 2) When the servo motor has a power supply lead, use a fixed terminal block to connect it with the servo amplifier. Do not connect cables directly.



- 3) Use the servo motor side power connector which complies with the EN Standard. The EN Standard-compliant power connector sets are available from us as options.

(7) Auxiliary equipment and options

- 1) The no-fuse breaker and magnetic contactor used should be the EN or IEC Standard-compliant products of the models described in Section 6-2-1.
- 2) The sizes of the cables described in Section 6-2-2 meet the following requirements. To meet the other requirements, follow Table 5 and Appendix C in EN60204-1.
  - Ambient temperature: 40 (104) [°C(°F)]
  - Sheath: PVC (polyvinyl chloride)
  - Installed on wall surface or open table tray
- 3) Use the EMC filter for noise reduction. The radio noise filter (FR-BIF) is not needed.

(8) Servo motor

For outline dimension drawings not shown, contact Mitsubishi.

(9) Performing EMC tests

When EMC tests are run on a machine/device into which the servo amplifier has been installed, it must conform to the electromagnetic compatibility (immunity/emission) standards after it has satisfied the operating environment/electrical equipment specifications.

For the other EMC Directive guidelines on the servo amplifier, refer to the "EMC INSTALLATION GUIDELINES (IB(NA)67310)".

## CONFORMANCE WITH UL/C-UL STANDARD

(1) Servo amplifiers and servo motors used

Use the following models of servo amplifiers and servo motors:

Servo amplifier series: MR-J2-10A to MR-J2-350A

Servo motor series : HC-KF -UE  
 HC-MF -UE  
 HC-SF   
 HC-RF   
 HC-UF

(2) Installation

Install a fan of 100CFM air flow 10.16 cm (4 in) above the servo amplifier or provide cooling of at least equivalent capability.

(3) Short-circuit rating

Having been subjected to UL's short-circuit test with an AC circuit whose peak current is limited to 5000A max., this servo amplifier complies with this circuit.

(4) Flange

Mount the servo motor on a flange which has the following size or produces an equivalent or higher heat dissipation effect:

Flange Size [mm]	Servo Motor				
	HC-MF <input type="checkbox"/> -UE	HA-FF <input type="checkbox"/> C-UE	HC-SF <input type="checkbox"/>	HC-RF <input type="checkbox"/>	HC-UF <input type="checkbox"/>
150 x 150 x 6	053 • 13	053 • 13			13
250 x 250 x 6	23	23 • 33			23
250 x 250 x 12	43	43 • 63	81 52 to 152 53 to 153	103 to 203	43
300 x 300 x 12	73				73
300 x 300 x 20			121 to 301 202 • 352 203 • 353		
550 x 550 x 30					72 • 152
650 x 650 x 35			301		202

(5) Capacitor discharge time

The capacitor discharge time is as listed below. To ensure safety, do not touch the charging section for 10 minutes after power-off.

Servo Amplifier	Discharge Time [min]
MR-J2-10A(1)•20A(1)	1
MR-J2-40A(1)•60A	2
MR-J2-70A~350A	3

(6) Options and auxiliary equipment

Use products which conform to the UL/C-UL Standard.

# CONTENTS

<b>CHAPTER 1 INTRODUCTION .....</b>	<b>1-1~1-17</b>
1-1 Inspection at delivery .....	1-2
1-1-1 Packing list .....	1-2
1-1-2 Model definition .....	1-2
1-1-3 Combination with servo motor .....	1-7
1-2 Parts identification and applications .....	1-8
1-2-1 Servo amplifier .....	1-8
1-2-2 Servo motor .....	1-13
1-3 Function list .....	1-14
1-4 Basic configuration .....	1-15
1-4-1 MR-J2-100A or less .....	1-15
1-4-2 MR-J2-200A or more .....	1-17
<b>CHAPTER 2 OPERATION .....</b>	<b>2-1~2-54</b>
2-1 Standard connection examples .....	2-2
2-1-1 Position control mode .....	2-2
2-1-2 Speed control mode .....	2-6
2-1-3 Torque control mode .....	2-8
2-2 Operation .....	2-10
2-2-1 Pre-operation checks .....	2-10
2-2-2 Start-up .....	2-11
2-3 Display and operation .....	2-18
2-3-1 Display flowchart .....	2-18
2-3-2 Status display .....	2-19
2-3-3 Diagnostic mode .....	2-20
2-3-4 Alarm mode .....	2-27
2-3-5 Parameter mode .....	2-28
2-4 Adjustments .....	2-50
2-4-1 Auto tuning .....	2-50
2-4-2 Manual gain adjustment .....	2-50
2-4-3 Slight vibration suppression control .....	2-54
<b>CHAPTER 3 WIRING .....</b>	<b>3-1~3-62</b>
3-1 Servo amplifier .....	3-3
3-1-1 Terminal blocks .....	3-3
3-1-2 Signal connectors .....	3-6
3-1-3 Detailed information on I/O signals .....	3-18
3-1-4 Interfaces .....	3-32
3-2 Connection of servo amplifier and servo motor .....	3-36
3-2-1 Connection instructions .....	3-36
3-2-2 Connection diagram .....	3-37
3-2-3 I/O terminals .....	3-38
3-2-4 Connectors used for servo motor wiring .....	3-41
3-3 Common line .....	3-55
3-4 Grounding .....	3-56
3-5 Power supply circuit .....	3-57
3-6 Alarm occurrence timing chart .....	3-59
3-7 Servo motor with electromagnetic brake .....	3-60
<b>CHAPTER 4 INSTALLATION .....</b>	<b>4-1~4-9</b>
4-1 Servo amplifier .....	4-2
4-2 Servo motor .....	4-5

<b>CHAPTER 5</b>	<b>ABSOLUTE POSITION DETECTION SYSTEM .....</b>	<b>5-1~5-6</b>
<b>CHAPTER 6</b>	<b>OPTIONS AND AUXILIARY EQUIPMENT .....</b>	<b>6-1~6-27</b>
6-1	Dedicated options .....	6-2
6-1-1	Regenerative brake options .....	6-2
6-1-2	Cable connectors .....	6-7
6-1-3	Junction terminal block .....	6-14
6-1-4	Maintenance junction card .....	6-15
6-1-5	Set-up software (will be released soon) .....	6-16
6-2	Auxiliary equipment .....	6-17
6-2-1	Cables .....	6-17
6-2-2	No-fuse breakers, fuses, magnetic contactors .....	6-17
6-2-3	Power factor improving reactors .....	6-18
6-2-4	Relays .....	6-18
6-2-5	Surge absorbers .....	6-19
6-2-6	Noise reduction techniques .....	6-20
6-2-7	Leakage current breaker .....	6-25
6-2-8	Battery (MR-BAT, A6BAT) .....	6-26
6-2-9	Setting potentiometers for analog inputs .....	6-27
<b>CHAPTER 7</b>	<b>INSPECTION .....</b>	<b>7-1~7-3</b>
<b>CHAPTER 8</b>	<b>TROUBLESHOOTING .....</b>	<b>8-1~8-13</b>
8-1	Troubleshooting at start-up .....	8-2
8-1-1	Position control mode .....	8-2
8-1-2	Speed control mode .....	8-4
8-1-3	Torque control mode .....	8-5
8-2	Alarms and warnings .....	8-6
8-2-1	Alarm and warning list .....	8-6
8-2-2	Alarms .....	8-7
8-2-3	Warnings .....	8-13
<b>CHAPTER 9</b>	<b>CHARACTERISTICS .....</b>	<b>9-1~9-12</b>
9-1	Overload protection characteristics .....	9-2
9-2	Losses generated in the servo amplifier .....	9-4
9-3	Electromagnetic brake characteristics .....	9-6
9-4	Dynamic brake characteristics .....	9-10
9-5	Vibration rank .....	9-12
<b>CHAPTER 10</b>	<b>SPECIFICATIONS .....</b>	<b>10-1~10-110</b>
10-1	Standard specifications .....	10-2
10-2	Torque characteristics .....	10-6
10-3	Servo motors with reduction gears .....	10-10
10-4	Servo motors with special shafts .....	10-14
10-5	Outline dimension drawings .....	10-16
10-5-1	Servo amplifiers .....	10-16
10-5-2	Servo motors .....	10-19
10-5-3	Servo motors (in inches) .....	10-61
10-5-4	Cable side plugs .....	10-103

<b>CHAPTER 11 SELECTION</b> .....	<b>11-1~11-13</b>
11-1 Specification symbol list .....	11-2
11-2 Position resolution and electronic gear setting .....	11-3
11-3 Speed and command pulse frequency .....	11-4
11-4 Stopping characteristics .....	11-5
11-5 Capacity selection.....	11-6
11-6 Load torque equations .....	11-8
11-7 Load inertia moment equations .....	11-9
11-8 Precautions for zeroing .....	11-10
11-9 Selection example.....	11-11

# CHAPTER 1

## INTRODUCTION

---

This chapter provides basic information needed to use this servo.

- 1-1 Inspection at delivery
  - 1-1-1 Packing list
  - 1-1-2 Model definition
  - 1-1-3 Combination with servo motor
- 1-2 Parts identification and applications
  - 1-2-1 Servo amplifier
  - 1-2-2 Servo motor
- 1-3 Function list
- 1-4 Basic configuration
  - 1-4-1 MR-J2-100A or less
  - 1-4-2 MR-J2-200A or more

<b>INTRODUCTION</b>	<b>CHAPTER 1</b>
<b>OPERATION</b>	<b>CHAPTER 2</b>
<b>WIRING</b>	<b>CHAPTER 3</b>
<b>INSTALLATION</b>	<b>CHAPTER 4</b>
<b>ABSOLUTE POSITION DETECTION SYSTEM</b>	<b>CHAPTER 5</b>
<b>OPTIONS AND AUXILIARY EQUIPMENT</b>	<b>CHAPTER 6</b>
<b>INSPECTION</b>	<b>CHAPTER 7</b>
<b>TROUBLESHOOTING</b>	<b>CHAPTER 8</b>
<b>CHARACTERISTICS</b>	<b>CHAPTER 9</b>
<b>SPECIFICATIONS</b>	<b>CHAPTER 10</b>
<b>SELECTION</b>	<b>CHAPTER 11</b>

# 1. INTRODUCTION

## 1-1 Inspection at delivery

After unpacking, check the name plate to make sure that the servo amplifier and servo motor received are as ordered by the customer.

### 1-1-1 Packing list

#### 1) Servo amplifier

Item	Qty
Servo amplifier	1
(Note)Control circuit connector	1
Specifications and installation guide	1

Note: Not supplied to the servo amplifier of MR-J2-200A or more.

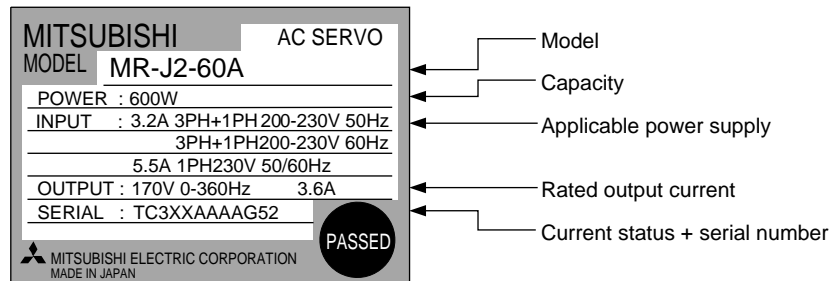
#### 2) Servo motor

Item	Qty
Servo motor	1
Safety Instructions for Use of AC Servo	1

### 1-1-2 Model definition

#### (1) Servo amplifier

##### 1) Name plate



##### 2) Model

MR-J2-□A□  
Series

Symbol	Power Supply
None	Three-phase AC200~230V (Note 2) Single-phase AC230V
(Note 1) 1	Single-phase AC100V

Note: 1. Not supplied to the servo amplifier of MR-J2-60A or more.  
2. Not supplied to the servo amplifier of MR-J2-100A or more.

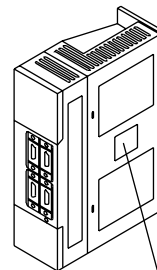
General-purpose Interface

Rated output

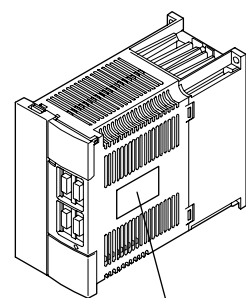
Symbol	Rated output [W]	Symbol	Rated output [W]
10	100	70	750
20	200	100	1000
40	400	200	2000
60	600	350	3500

MR-J2-100A or less

MR-J2-200A•350A



Name plate

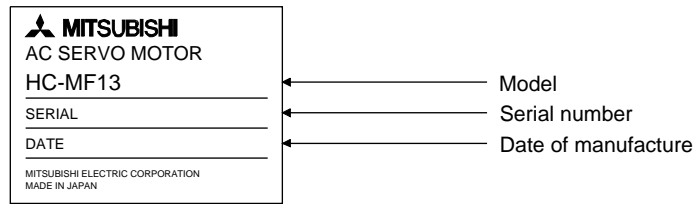


Name plate

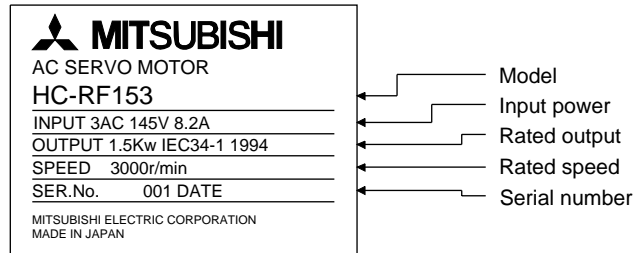
# 1. INTRODUCTION

## (2) Servo Motors

### 1) Name plate



or



### 2) Model

#### a. HC-MF series (ultra low inertia, small capacity)

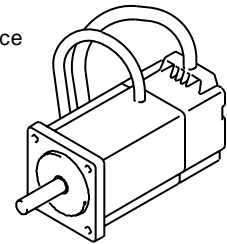
HC-MF □ 3 □ □ □ □

Series name

#### 1) Compliance with Standard

Symbol	Specifications
None	Standard model (Japan)
-UE	EN • UL/C-UL Standard

Appearance



#### 2) Shaft type

Symbol	Shaft Shape	HC-MF□
None	Standard (Straight shaft)	053 to 73
K	(Note) With keyway	23 to 73
D	D-cut shaft	53 • 13

Note: With key

#### 3) Reduction gear

Symbol	Reduction Gear
None	Without
G1	For general industrial machine
G2	For precision application

#### 4) Electromagnetic brake

Symbol	Electromagnetic Brake
None	Without
B	With

#### 5) Rated speed 3000 [r/min]

#### 6) Rated output

Symbol	Rated Output [W]
05	50
1	100
2	200
4	400
7	750



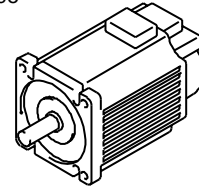
# 1. INTRODUCTION

## b. HA-FF series (low inertia, small capacity)

HA-FF□ 3 □ □ □ □ □

Series name

Appearance



1) Compliance with Standard

Symbol	Specifications
None	Standard model (Japan)
-UE	EN • UL/C-UL Standard

2) Shaft type

Symbol	Shaft Shape	HA-FF□
None	(Note) Standard	053 to 73
D	D-cut shaft	053 • 13

Note: The Standard shafts of the HA-FF23 to 63 are with keys and those of the other models are straight shafts.

3) Reduction gear

Symbol	Reduction Gear
None	Without
G1	For general industrial machine
G2	For precision application

4) Electromagnetic brake

Symbol	Electromagnetic Brake
None	Without
B	With

5) Input power supply form

Symbol	Standard model	EN • UL/C-UL Standard-compliant model
None	Lead	
C		Cannon connector

6) Rated speed  
3000 [r/min]

7) Rated output

Symbol	Rated Output [W]	Symbol	Rated Output [W]
05	50	3	300
1	100	4	400
2	200	6	600

# 1. INTRODUCTION

## c. HC-SF series (middle inertia, middle capacity)

HC-SF □□□□□

Series name

### 1) Shaft type

Symbol	Shaft shape
None	Standard (Straight shaft)
K	With keyway

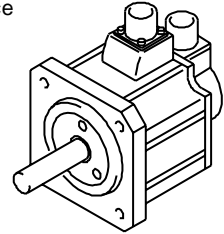
Note: Without key

### 2) Reduction gear

Symbol	(Note) Reduction Gear
None	Without
G1	For general industrial machine (flange type)
G1H	For general industrial machine (leg type)
G2	For precision application

Note: Not provided for 1000r/min and 3000r/min series.

Appearance



### 4) Rated speed

Symbol	Speed [r/min]
1	1000
2	2000
3	3000

### 3) Electromagnetic brake

Symbol	Electromagnetic Brake
None	Without
B	With

### 5) Rated output

Symbol	Rated Output [W]	1000 [r/min]	2000 [r/min]	3000 [r/min]
5	500	○	○	○
8	850	○	○	○
10	1000	○	○	○
12	1200	○	○	○
15	1500	○	○	○
20	2000	○	○	○
30	3000	○	○	○
35	3500	○	○	○

# 1. INTRODUCTION

## d. HC-RF series (low inertia, middle capacity)

HC-RF □ 3 □ □ □

Series name

1) Shaft type

Symbol	Shaft Shape
None	Standard (Straight shaft)
K	With keyway

Note: Without key

2) Reduction gear

Symbol	Reduction Gear
None	Without
G2	For precision application

3) Electromagnetic brake

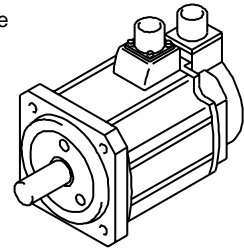
Symbol	Electromagnetic Brake
None	Without
B	With

4) Rated speed  
3000 [r/min]

5) Rated output

Symbol	Rated Output [W]
10	1000
15	1500
20	2000

Appearance



## e. HC-UF series (pancake type small capacity)

HC-UF □ 3 □ □ □

Series name

1) Shaft type

Symbol	Shaft Shape	HU-UF□
None	Standard (Straight shaft)	13 to 43 72 to 202
K	With keyway	
D	D-cut shaft	13

Note: Without key

2) Electromagnetic brake

Symbol	Electromagnetic Brake
None	Without
B	With

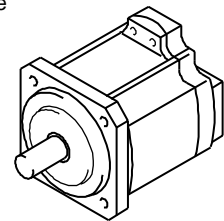
3) Rated speed

Symbol	Speed [r/min]
2	2000
3	3000

4) Rated output

Symbol	Rated Output [W]
1	100
2	200
4	400
7	750
15	1500
20	2000

Appearance



# 1. INTRODUCTION

## 1-1-3 Combination with servo motor

The following table lists combinations of servo amplifiers and servo motors. The same combinations apply to the models with electromagnetic brakes, the models with reduction gears, the EN Standard-compliant models and UL/C-UL Standard-compliant models.

Servo Amplifier	Servo Motors							
	HC-MF□	HA-FF□	HC-SF□ (Note)			HC-RF□	HC-UF□ (Note)	
			1000r/min	2000r/min	3000r/min		2000r/min	3000r/min
MR-J2-10A (1)	053 • 13	053 • 13						13
MR-J2-20A (1)	23	23						23
MR-J2-40A (1)	43	33 • 43						43
MR-J2-60A		63		52	53			
MR-J2-70A	73						72	73
MR-J2-100A			81	102	103			
MR-J2-200A			121 • 201	152 • 202	153 • 203	103 • 153	152	
MR-J2-350A			301	352	353	203	202	

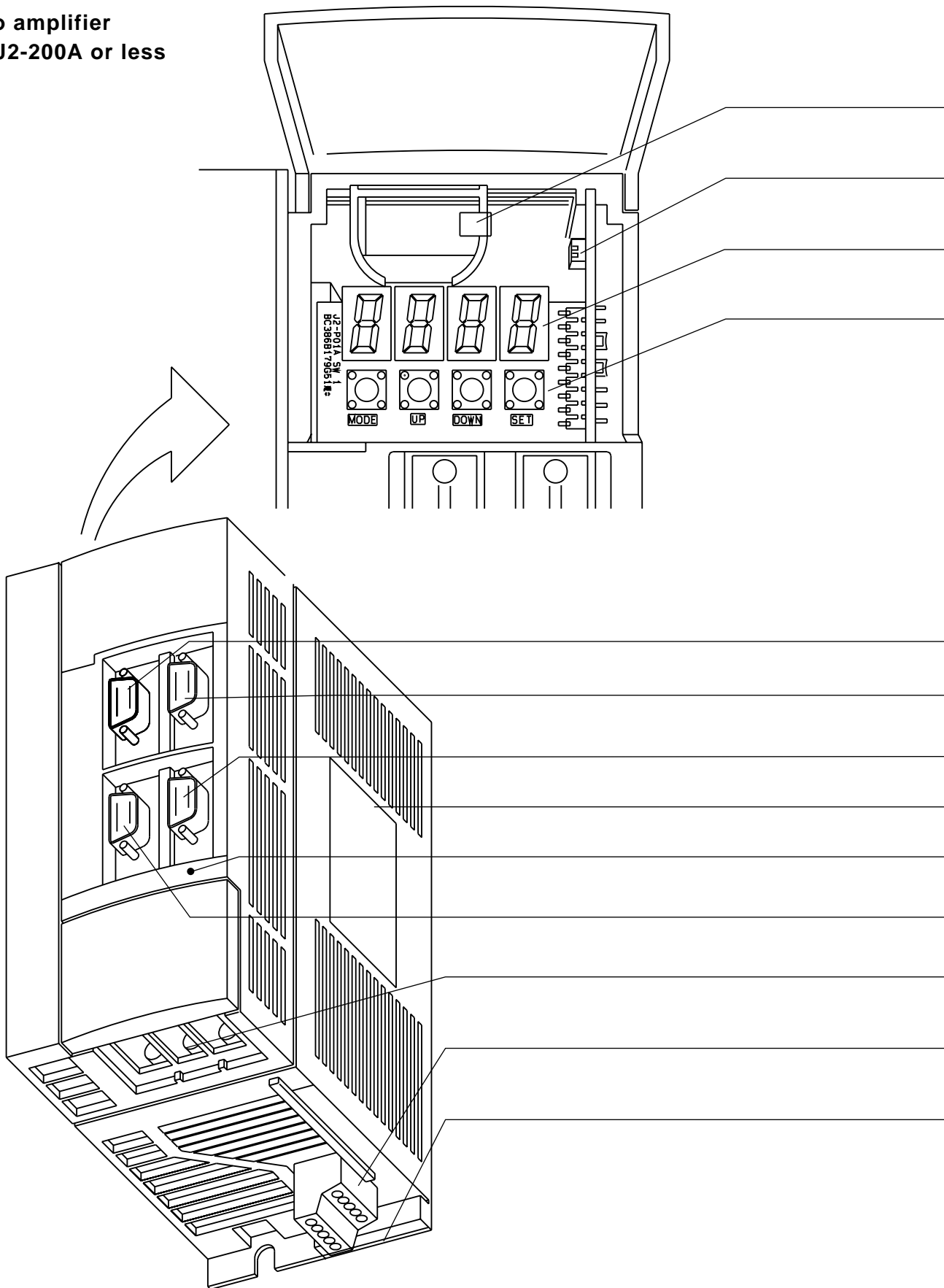
Note The HC-UF73 • HC-SF203 • HC-SF353 may not be connected depending on the production timing of the servo amplifier. Please contact us.

# 1. INTRODUCTION

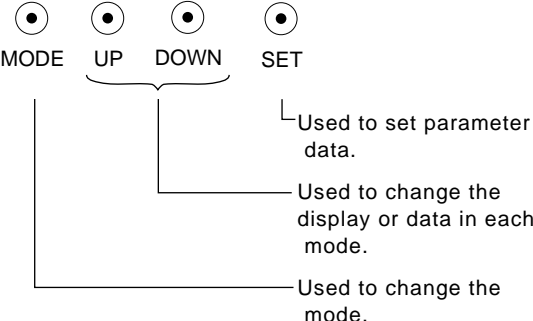
## 1-2 Parts identification and applications

### 1-2-1 Servo amplifier

(1) MR-J2-200A or less

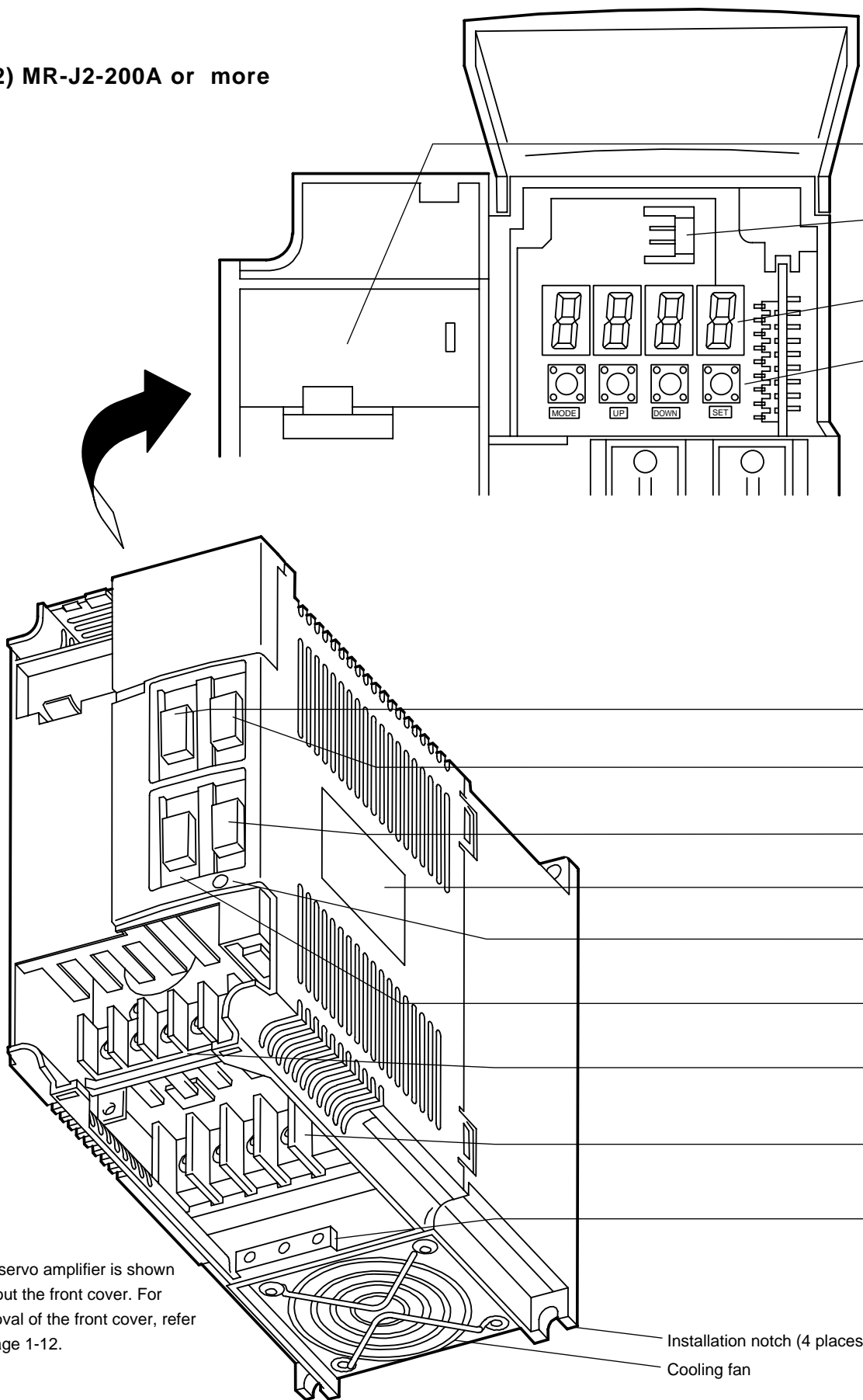


# 1. INTRODUCTION

Name/Application	Refer To
Battery holder Contains the battery for absolute position data backup.	Chapter 5(5)
Battery connector (CON1) Used to connect the battery for absolute position data backup.	Chapter 5(5) Section 6-2-8
Display The four-digit, seven-segment LED shows the servo status and alarm number.	Section 2-3
Operation section Used to perform status display, diagnostic, alarm and parameter setting operations. 	Section 2-3
I/O signal connector (CN1A) Used to connect digital I/O signals.	Section 3-1-2
I/O signal connector (CN1B) Used to connect digital I/O signals.	Section 3-1-2
Communication connector (CN3) Used to connect a personal computer or output analog monitor.	Section 3-1-2 Section 6-1-5
Name plate	Section 1-1
Charge lamp Lit to indicate that the main circuit is charged. While this lamp is lit, do not reconnect the cables.	/
Encoder connector (CN2) Connector for connection of the servo motor encoder	Section 3-1-2
Main circuit terminal block (TE1) Used to connect the input power supply and servo motor.	Section 3-1-1
Control circuit terminal block (TE2) Used to connect the control circuit power supply and regenerative brake option.	Section 3-1-1
Protective earth (PE) terminal (Ⓧ) Ground terminal.	Section 3-4

# 1. INTRODUCTION

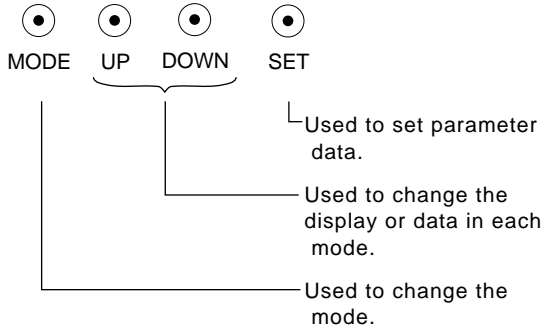
(2) MR-J2-200A or more



The servo amplifier is shown without the front cover. For removal of the front cover, refer to page 1-12.

Installation notch (4 places)  
Cooling fan

# 1. INTRODUCTION

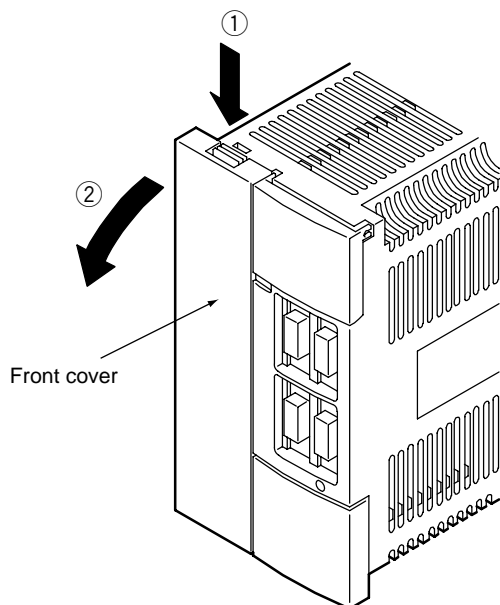
Name/Application	Refer To
Battery holder Contains the battery for absolute position data backup.	Chapter 5(5)
Battery connector (CON1) Used to connect the battery for absolute position data backup.	Chapter 5(5) Section 6-2-8
Display The four-digit, seven-segment LED shows the servo status and alarm number.	Section 2-3
Operation section Used to perform status display, diagnostic, alarm and parameter setting operations.  	Section 2-3
I/O signal connector (CN1A) Used to connect digital I/O signals.	Section 3-1-2
I/O signal connector (CN1B) Used to connect digital I/O signals.	Section 3-1-2
Communication connector (CN3) Used to connect a personal computer or output analog monitor.	Section 3-1-2 Section 6-1-5
Name plate	Section 1-1
Charge lamp Lit to indicate that the main circuit is charged. While this lamp is lit, do not reconnect the cables.	/
Encoder connector (CN2) Connector for connection of the servo motor encoder	Section 3-1-2
Control circuit terminal block (TE2) Used to connect the control circuit power supply and regenerative brake option. Control circuit terminal	Section 3-1-1
Main circuit terminal block (TE1) Used to connect the input power supply and servo motor.	Section 3-1-1
Protective earth (PE) terminal (Ⓧ) Ground terminal.	Section 3-4



# 1. INTRODUCTION

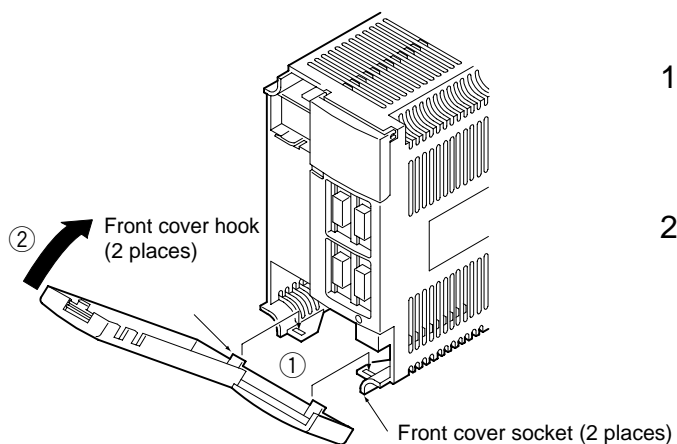
---

## Removal of the front cover



- 1) Hold down the removing knob.
- 2) Pull the front cover toward you.

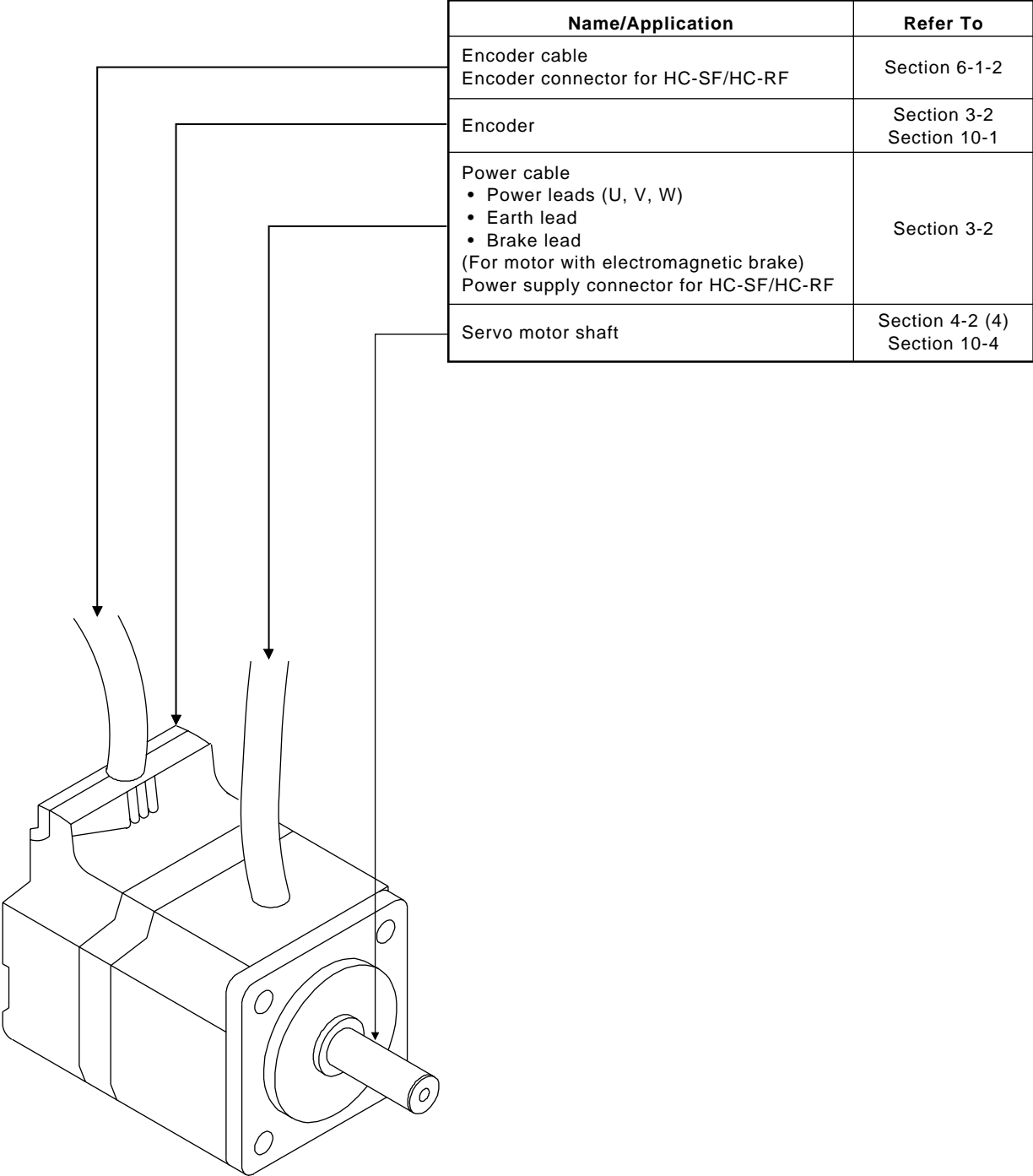
## Reinstallation of the front cover



- 1) Insert the front cover hooks into the front cover sockets of the servo amplifier.
- 2) Press the front cover against the servo amplifier until the removing knob clicks.

# 1. INTRODUCTION

## 1-2-2 Servo motor



# 1. INTRODUCTION

## 1-3 Function list

Function	Description	(Note) Control Mode	Refer To
Position control mode	MR-J2-A is used as position control servo.	P	Section 2-1-1 Section 2-2-2 (2) Section 3-1-3 (1)
Speed control mode	MR-J2-A is used as speed control servo.	S	Section 2-1-2 Section 2-2-2 (3) Section 3-1-3 (2)
Torque control mode	MR-J2-A is used as torque control servo.	T	Section 2-1-3 Section 2-2-2 (4) Section 3-1-3 (3)
Position/speed control change mode	Using external input signal, control can be switched between position control and speed control.	P/S	Section 3-1-3 (4)
Speed/torque control change mode	Using external input signal, control can be switched between speed control and torque control.	S/T	Section 3-1-3 (5)
Torque/position control change mode	Using external input signal, control can be switched between torque control and position control.	T/P	Section 3-1-3 (6)
Absolute position detection system	Return to home position is not required at each power on after it has been made once.	P	Chapter 5
Slight vibration suppression control	Suppresses vibration of $\pm 1$ pulse produced at a servo motor stop.	P	Section 2-4-3
Electronic gear	Input pulses can be multiplied by 1/50 to 50.	P	Parameters No. 3, 4
Real-time auto tuning	Automatically adjusts the gain to optimum value if load applied to the servo motor shaft varies.	P, S	Section 2-4-1 Parameter No. 2
Smoothing	Speed can be increased smoothly in response to input pulse.	P	Parameter No. 7
S-pattern acceleration/deceleration time constant	Speed can be increased and decreased smoothly.	S	Parameter No. 13
Analog monitor output	Servo status is output in terms of voltage in real time.	P, S, T	Parameter No. 17
Alarm history clear	Alarm history is cleared.	P, S, T	Parameter No. 16
Restart after instantaneous power failure	If the input power supply voltage had reduced to cause an alarm but has returned to normal, the servo motor can be restarted by merely switching on the start signal.	S	Parameter No. 20
Command pulse selection	Command pulse train form can be selected from among four different types.	P	Parameter No. 21
Input signal selection	Forward rotation start, reverse rotation start, servo on and other input signals can be assigned to any pins.	P, S, T	Parameters No. 43 to 48
Torque limit	Servo motor-generated torque can be limited to any value.	P, S	Section 3-1-3 (1) ① Parameter No. 28
Speed limit	Servo motor speed can be limited to any value.	T	Section 3-1-3 (3) ③ Parameter No. 8-10
Status display	Servo status is shown on the 4-digit, 7-segment LED display.	P, S, T	Section 2-3-2
External I/O display	ON/OFF statuses of external I/O signals are shown on the display.	P, S, T	Section 2-3-3 (1)
Output signal forced output	Output signal can be forced on/off independently of the servo status. Use this function for output signal wiring check, etc.	P, S, T	Section 2-3-3 (2)
Automatic VC offset	Voltage is automatically offset to stop the servo motor if it does not come to a stop at the analog speed command (VC) or analog speed limit (VLA) of 0V.	S, T	Section 2-3-3
Test operation mode	Servo motor can be run from the operation section of the servo amplifier without the start signal entered.	P, S, T	Section 2-3-3 (3)
Regenerative brake option	Used when the built-in regenerative brake resistor of the servo amplifier does not have sufficient regenerative capability for the regenerative power generated.	P, S, T	Section 6-1-1
Servo configuration software	Using a personal computer, parameter setting, test operation, status display, etc. can be performed.	P, S, T	Section 6-1-5
Alarm code output	If an alarm has occurred, the corresponding alarm number is output in 3-bit code.	P, S, T	Section 8-2-1

Note: P: Position control mode, S: Speed control mode, T: Torque control mode

P/S: Position/speed control change mode, S/T: Speed/torque control change mode, T/P: Torque/position control change mode

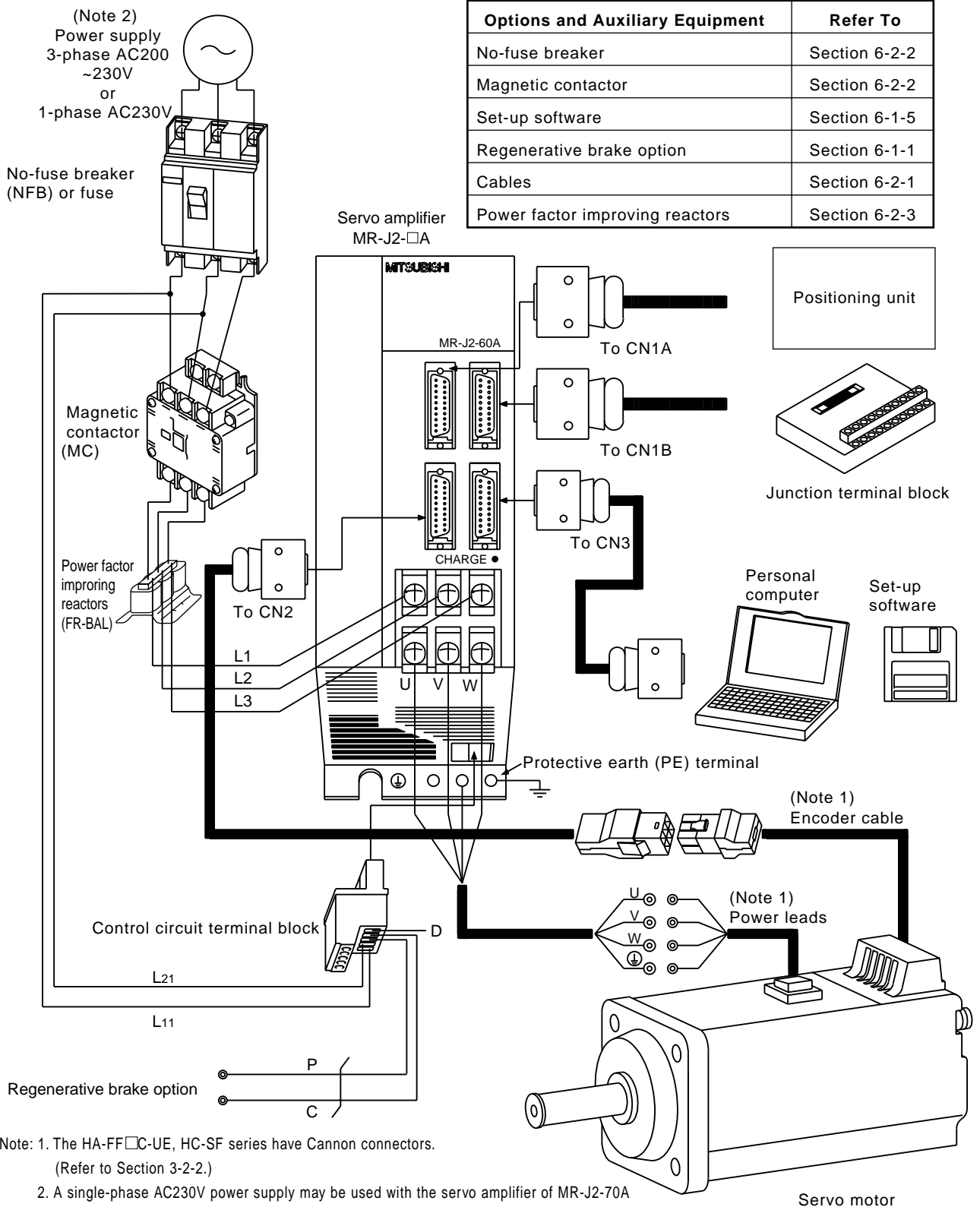
# 1. INTRODUCTION

## 1-4 Basic configuration

**⚠ WARNING** To prevent an electric shock, always connect the protective earth (PE) terminal (terminal marked ⊕) of the servo amplifier to the protective earth (PE) of the control box.

### 1-4-1 MR-J2-100A or less

#### (1) Three-phase 200V or single-phase 230V power supply models



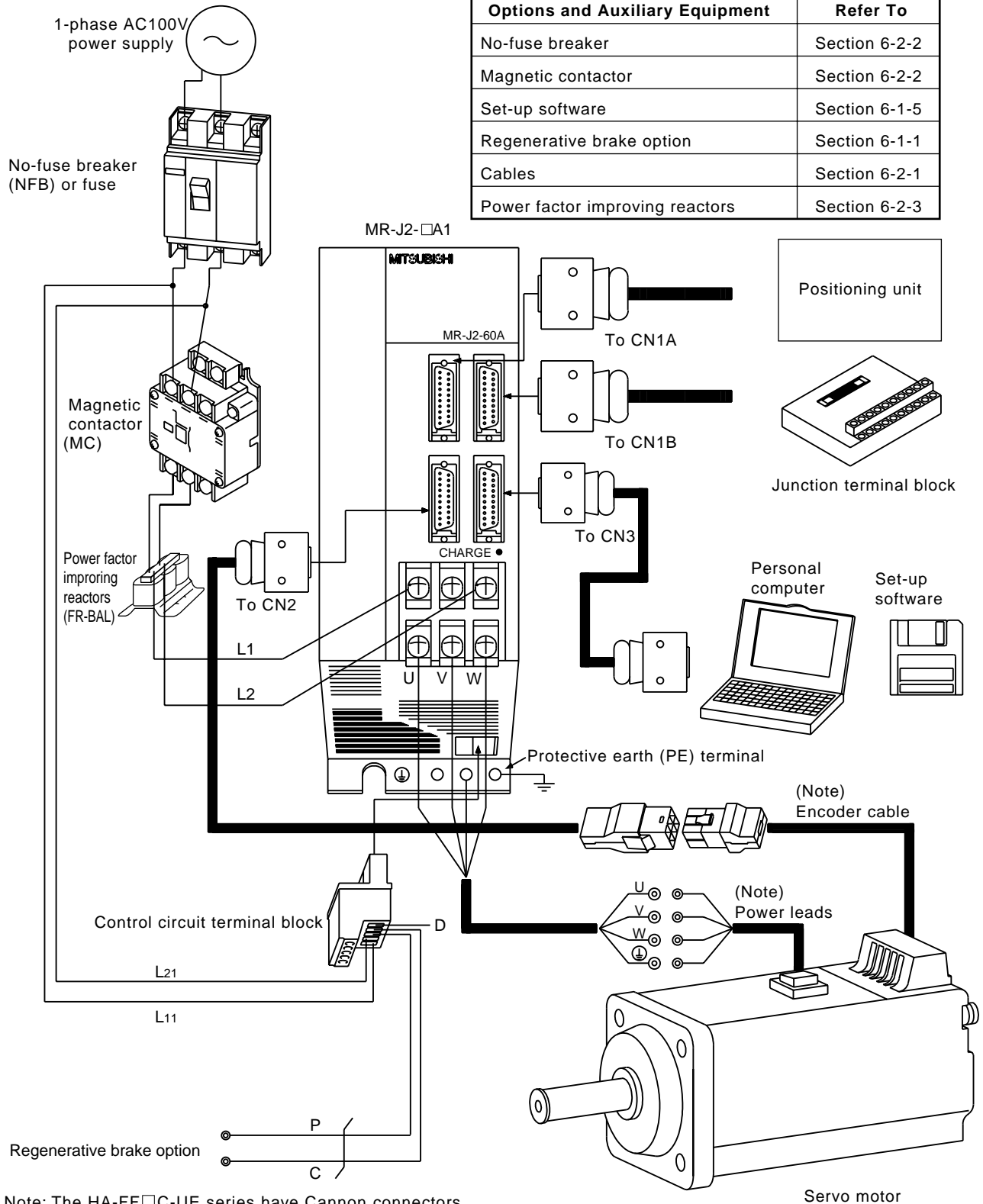
Note: 1. The HA-FF□C-UE, HC-SF series have Cannon connectors. (Refer to Section 3-2-2.)

2. A single-phase AC230V power supply may be used with the servo amplifier of MR-J2-70A or less. Connect the power supply to L1 and L2 terminals and leave L3 open.

# 1. INTRODUCTION

## (2) Single-phase 100V power supply model

Options and Auxiliary Equipment	Refer To
No-fuse breaker	Section 6-2-2
Magnetic contactor	Section 6-2-2
Set-up software	Section 6-1-5
Regenerative brake option	Section 6-1-1
Cables	Section 6-2-1
Power factor improving reactors	Section 6-2-3

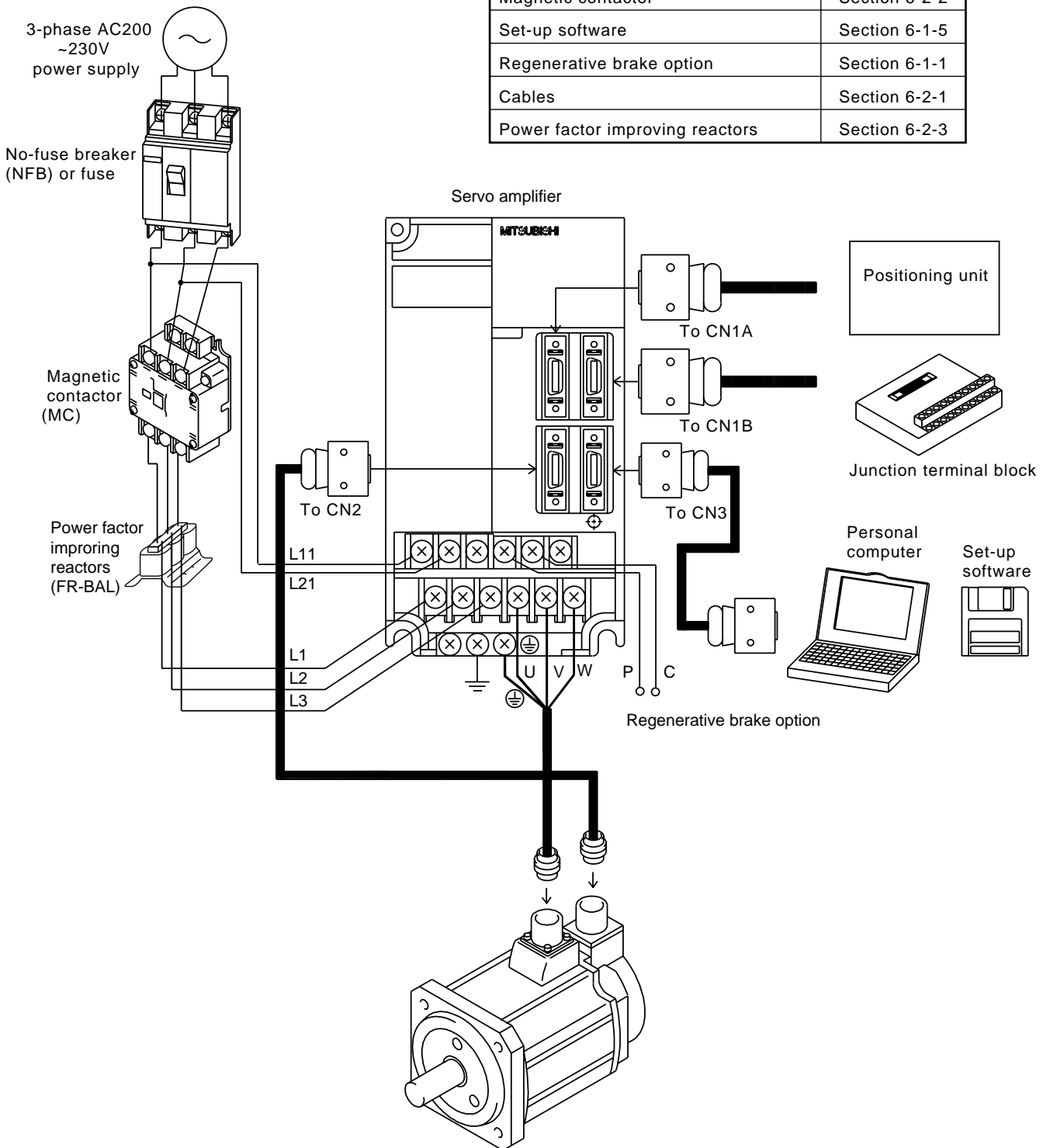


Note: The HA-FF□C-UE series have Cannon connectors.  
(Refer to Section 3-2-2.)

# 1. INTRODUCTION

## 1-4-2 MR-J2-200A or more

Options and Auxiliary Equipment	Refer To
No-fuse breaker	Section 6-2-2
Magnetic contactor	Section 6-2-2
Set-up software	Section 6-1-5
Regenerative brake option	Section 6-1-1
Cables	Section 6-2-1
Power factor improving reactors	Section 6-2-3



# CHAPTER 2

## OPERATION

---

This chapter gives basic connection examples and operation procedures.

- 2-1 Standard connection examples
  - 2-1-1 Position control mode
  - 2-1-2 Speed control mode
  - 2-1-3 Torque control mode
- 2-2 Operation
  - 2-2-1 Pre-operation checks
  - 2-2-2 Start-up
- 2-3 Display and operation
  - 2-3-1 Display flowchart
  - 2-3-2 Status display
  - 2-3-3 Diagnostic mode
  - 2-3-4 Alarm mode
  - 2-3-5 Parameter mode
- 2-4 Adjustments
  - 2-4-1 Auto tuning
  - 2-4-2 Manual gain adjustment
  - 2-4-3 Slight vibration suppression control

<b>INTRODUCTION</b>	<b>CHAPTER 1</b>
<b>OPERATION</b>	<b>CHAPTER 2</b>
<b>WIRING</b>	<b>CHAPTER 3</b>
<b>INSTALLATION</b>	<b>CHAPTER 4</b>
<b>ABSOLUTE POSITION DETECTION SYSTEM</b>	<b>CHAPTER 5</b>
<b>OPTIONS AND AUXILIARY EQUIPMENT</b>	<b>CHAPTER 6</b>
<b>INSPECTION</b>	<b>CHAPTER 7</b>
<b>TROUBLESHOOTING</b>	<b>CHAPTER 8</b>
<b>CHARACTERISTICS</b>	<b>CHAPTER 9</b>
<b>SPECIFICATIONS</b>	<b>CHAPTER 10</b>
<b>SELECTION</b>	<b>CHAPTER 11</b>





## 2. OPERATION

### WARNING

Note: 1. To prevent an electric shock, always connect the protective earth(PE) terminal (terminal marked ⊕ ) of the servo amplifier to the protective earth (PE) of the control box.

### CAUTION

Note: 2. Connect the diode in the correct direction. If it is connected reversely, the servo amplifier will be faulty and will not output signals, disabling the emergency stop and other protective circuits.  
3. The emergency stop switch must be installed.

### NOTICE

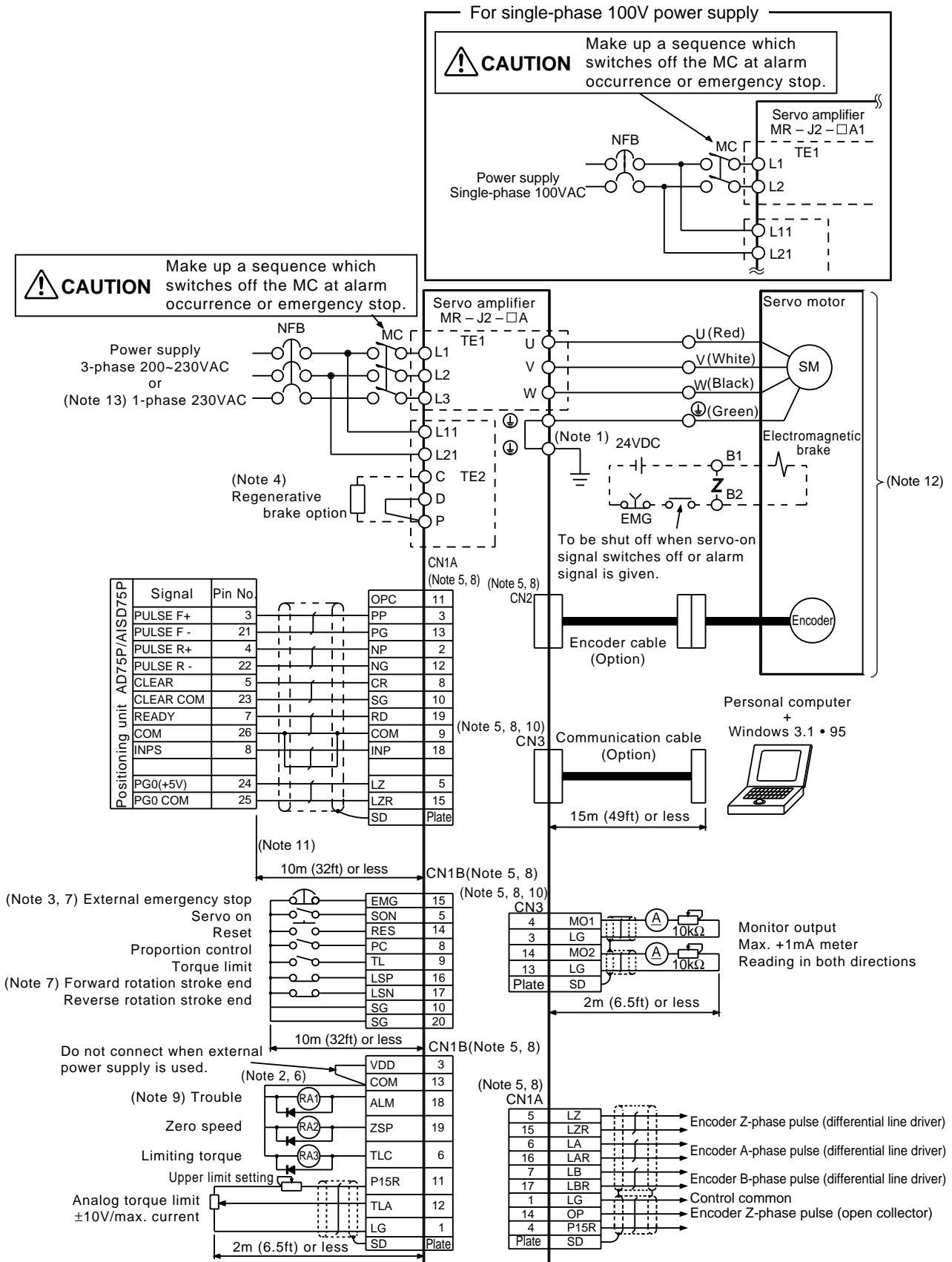
Note: 4. When using the regenerative brake option, always remove the lead from across D-P.  
5. CN1A, CN1B, CN2 and CN3 have the same shape. Wrong connection of the connectors will lead to a fault.  
6. The sum of currents that flow in the external relays should be 80mA max. If it exceeds 80mA, supply interface power from external.

### MEMORANDUM

Note: 7. When starting operation, always connect the external emergency stop signal (EMG) and forward/reverse rotation stroke end signal (LSN/LSP) with SG. (Normally closed contacts)  
8. The pins with the same signal name are connected in the servo amplifier.  
9. The trouble (ALM) signal is on when there is no alarm, i.e. in the normal state.  
When this signal is switched off (at occurrence of an alarm), the output of the controller should be stopped by the sequence program.  
10. When connecting the personal computer together with monitor outputs 1, 2, use the maintenance junction card (MR-J2CN3TM). (Refer to Section 6-1-4)  
11. This length applies to the command pulse train input in the opencollector system. It is 10m (32 ft) or less in the differential line driver system.  
12. The connection method changes with the servo motor series.  
Refer to Section 3-2-2.  
13. A single-phase 230V power supply may be used with the servo amplifier of MR-J2-70A or less. Connect the power supply to L1 and L2 terminals and leave L3 open.  
14. When using the relay terminal block (MR-TB20), connect it to CN1A-10.

## 2. OPERATION

### (2) Connection with the AD75P □ /A1SD75P □



## 2. OPERATION

### WARNING

Note: 1. To prevent an electric shock, always connect the protective earth (PE) terminal (terminal marked  $\oplus$ ) of the servo amplifier to the protective earth (PE) of the control box.

### CAUTION

Note: 2. Connect the diode in the correct direction. If it is connected reversely, the servo amplifier will be faulty and will not output signals, disabling the emergency stop and other protective circuits.  
3. The emergency stop switch must be installed.

### NOTICE

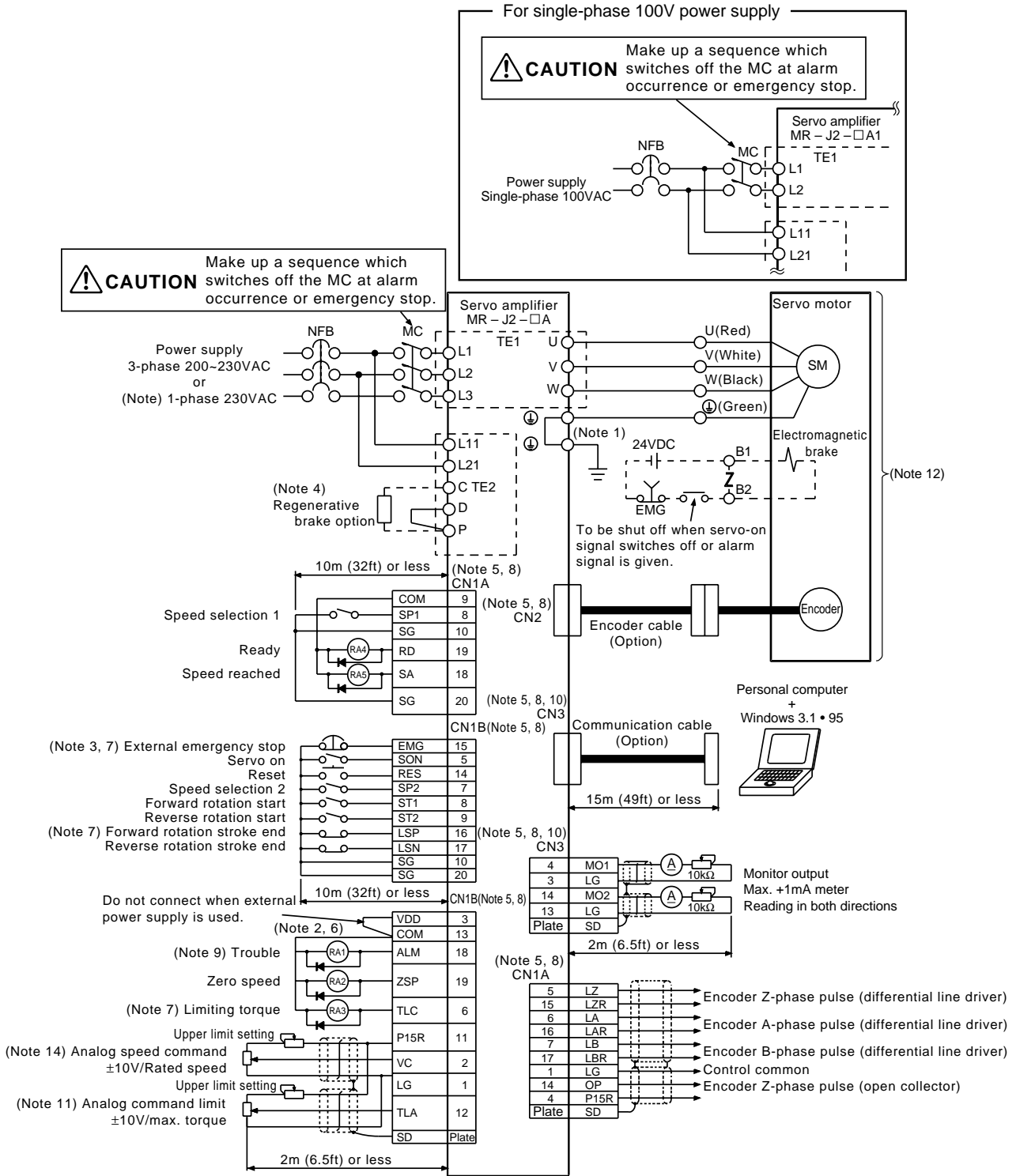
Note: 4. When using the regenerative brake option, always remove the lead from across D-P.  
5. CN1A, CN1B, CN2 and CN3 have the same shape. Wrong connection of the connectors will lead to a fault.  
6. The sum of currents that flow in the external relays should be 80mA max. If it exceeds 80mA, supply interface power from external.

### MEMORANDUM

Note: 7. When starting operation, always connect the external emergency stop signal (EMG) and forward/reverse rotation stroke end signal (LSN/LSP) with SG. (Normally closed contacts)  
8. The pins with the same signal name are connected in the servo amplifier.  
9. The trouble (ALM) signal is on when there is no alarm, i.e. in the normal state.  
When this signal is switched off (at occurrence of an alarm), the output of the controller should be stopped by the sequence program.  
10. When connecting the personal computer together with monitor outputs 1, 2, use the maintenance junction card (MR-J2CN3TM). (Refer to Section 6-1-4)  
11. This length applies to the command pulse train input in the differential line driver system. Though the command pulse train input may be in the open collector system, we recommend the differential line driver system which is less affected by external noises. The length is 2m (6.5ft) or less in the open collector system.  
12. The connection method changes with the servo motor series. Refer to Section 3-2-2.  
13. A single-phase 230V power supply may be used with the servo amplifier of MR-J2-70A or less. Connect the power supply to L1 and L2 terminals and leave L3 open.

# 2. OPERATION

## 2-1-2 Speed control mode



## 2. OPERATION

### WARNING

Note: 1. To prevent an electric shock, always connect the protective earth (PE) terminal (terminal marked  $\oplus$ ) of the servo amplifier to the protective earth (PE) of the control box.

### CAUTION

Note: 2. Connect the diode in the correct direction. If it is connected reversely, the servo amplifier will be faulty and will not output signals, disabling the emergency stop and other protective circuits.  
3. The emergency stop switch must be installed.

### NOTICE

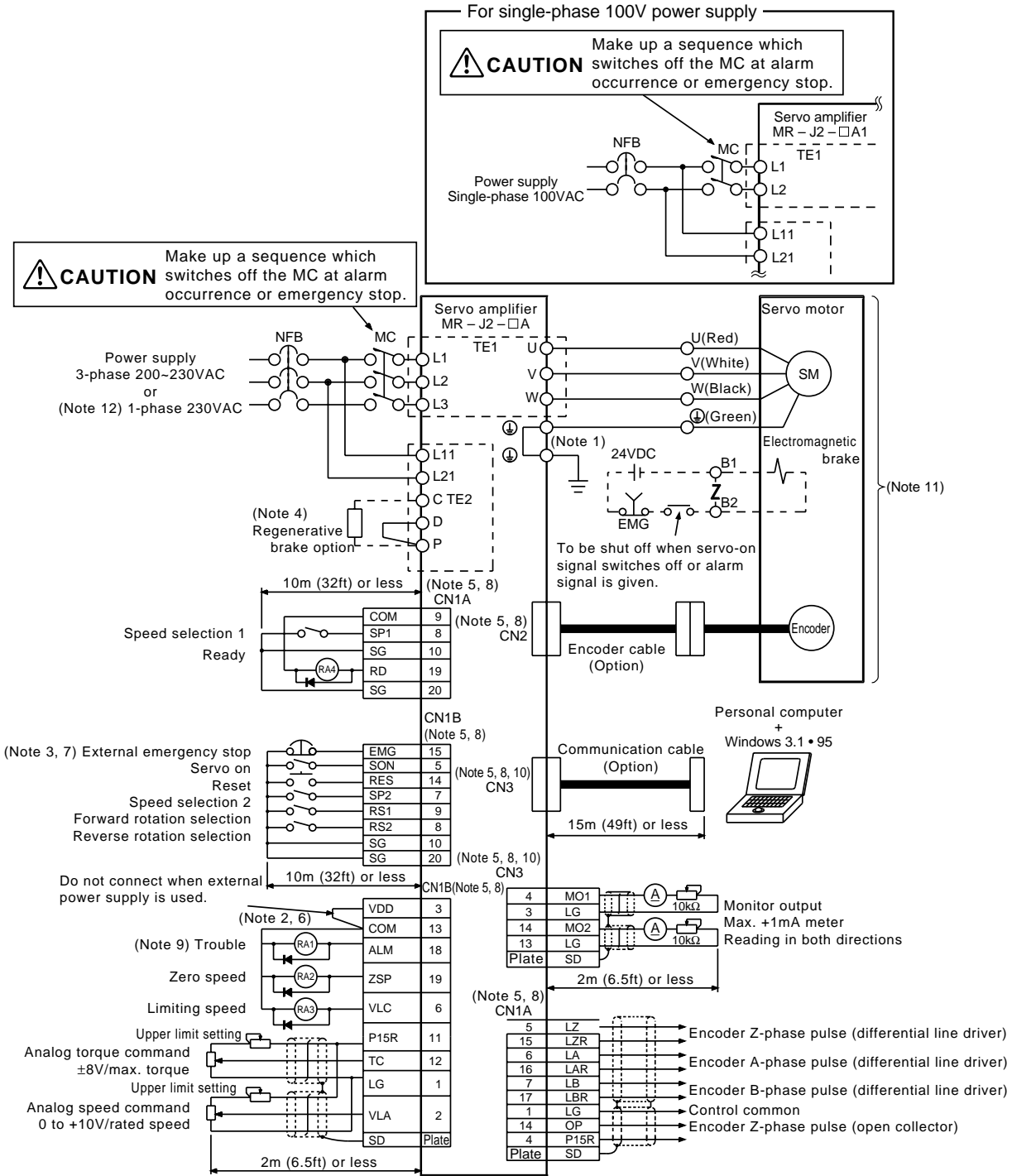
Note: 4. When using the regenerative brake option, always remove the lead from across D-P.  
5. CN1A, CN1B, CN2 and CN3 have the same shape. Wrong connection of the connectors will lead to a fault.  
6. The sum of currents that flow in the external relays should be 80mA max. If it exceeds 80mA, supply interface power from external.

### MEMORANDUM

Note: 7. When starting operation, always connect the external emergency stop signal (EMG) and forward/reverse rotation stroke end signal (LSN/LSP) with SG. (Normally closed contacts)  
8. The pins with the same signal name are connected in the servo amplifier.  
9. The trouble (ALM) signal is on when there is no alarm, i.e. in the normal state.  
When this signal is switched off (at occurrence of an alarm), the output of the controller should be stopped by the sequence program.  
10. When connecting the personal computer together with monitor outputs 1, 2, use the maintenance junction card (MR-J2CN3TM). (Refer to Section 6-1-4)  
11. TLA can be used by setting any of parameters No. 43 to 48 to make TL available.  
12. The connection method changes with the servo motor series. Refer to Section 3-2-2.  
13. A single-phase 230V power supply may be used with the servo amplifier of MR-J2-70A or less. Connect the power supply to L1 and L2 terminals and leave L3 open.  
14. When inputting a negative voltage, use the external power supply.

# 2. OPERATION

## 2-1-3 Torque control mode



For notes, refer to page 2-6.

## 2. OPERATION

### WARNING

Note: 1. To prevent an electric shock, always connect the protective earth (PE) terminal (terminal marked  $\oplus$ ) of the servo amplifier to the protective earth (PE) of the control box.

### CAUTION

Note: 2. Connect the diode in the correct direction. If it is connected reversely, the servo amplifier will be faulty and will not output signals, disabling the emergency stop and other protective circuits.  
3. The emergency stop switch must be installed.

### NOTICE

Note: 4. When using the regenerative brake option, always remove the lead from across D-P.  
5. CN1A, CN1B, CN2 and CN3 have the same shape. Wrong connection of the connectors will lead to a fault.  
6. The sum of currents that flow in the external relays should be 80mA max. If it exceeds 80mA, supply interface power from external.

### MEMORANDUM

Note: 7. When starting operation, always connect the external emergency stop signal (EMG) with SG. (Normally closed contacts)

8. The pins with the same signal name are connected in the servo amplifier.
9. The trouble (ALM) signal is on when there is no alarm, i.e. in the normal state.  
When this signal is switched off (at occurrence of an alarm), the output of the controller should be stopped by the sequence program.
10. When connecting the personal computer together with monitor outputs 1, 2, use the maintenance junction card (MR-J2CN3TM). (Refer to Section 6-1-4)
11. The connection method changes with the servo motor series. Refer to Section 3-2-2.
12. A single-phase 230V power supply may be used with the servo amplifier of MR-J2-70A or less. Connect the power supply to L1 and L2 terminals and leave L3 open.

## 2. OPERATION

### 2-2 Operation

#### 2-2-1 Pre-operation checks

Before starting operation, check the following:

##### (1) Wiring

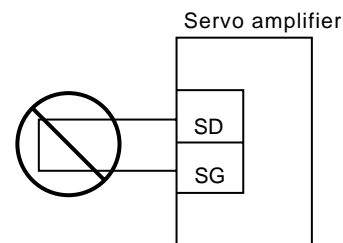
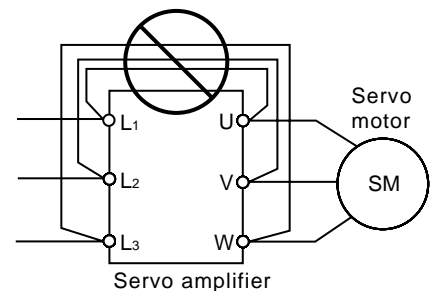
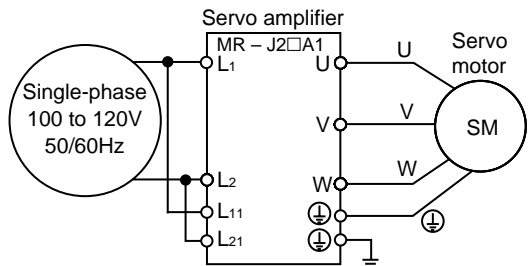
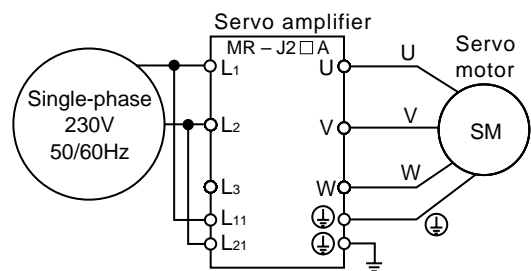
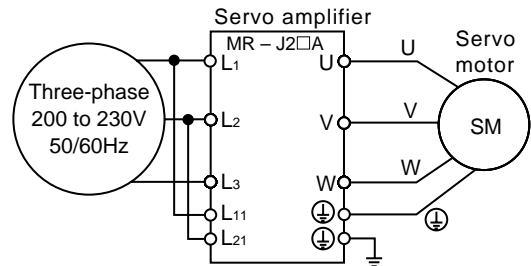
- 1) A correct power supply is connected to the power input terminals (three-phase 200V: L1, L2, L3; single-phase 230V: L1, L2; single-phase 100V: L1, L2) of the servo amplifier.
- 2) The servo motor power supply terminals (U, V, W) of the servo amplifier match in phase with the power input terminals (U, V, W) of the servo motor.
- 3) The servo motor power supply terminals (U, V, W) of the servo amplifier are not shorted to the power input terminals (L1, L2, L3) of the servo amplifier.
- 4) The servo amplifier and servo motor are grounded securely.
- 5) When the regenerative brake option is used, the lead has been removed across D-P of the control circuit terminal block. Also, twisted cables are used for its wiring.
- 6) When stroke end limit switches are used, the signals across LSP-SG and LSN-SG are on during operation.
- 7) 24VDC or higher voltages are not applied to the pins of connectors CN1A and CN1B.
- 8) SD and SG of connectors CN1A and CN1B are not shorted.
- 9) The wiring cables are free from excessive force.

##### (2) Environment

Signal cables and power cables are not shorted by wire offcuts, metallic dust or the like.

##### (3) Machine

- 1) The screws in the servo motor installation part and shaft-to-machine connection are tight.
- 2) The servo motor and the machine connected with the servo motor can be operated.





## 2. OPERATION

### 2-2-2 Start-up



#### **WARNING**

Do not operate the switches with wet hands. You may get an electric shock.



#### **CAUTION**

1. Before starting operation, check the parameters. Some machines may perform unexpected operation.
2. During power-on or soon after power-off, do not touch the servo amplifier heat sink, regenerative brake resistor, servo motor, etc. as they may be at high temperatures. You may get burnt.

#### (1) Selection of control mode

With parameter No. 0, select the control mode to be used. This parameter is made valid by setting it and switching power off once, then on again.

Parameter No. 0

--	--	--	--

Set Value	Control Mode
0	Position control mode
1	Position/speed control change mode
2	Speed control mode
3	Speed/torque control change mode
4	Torque control mode
5	Torque/position control change mode

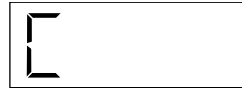
## 2. OPERATION

### (2) Position control mode

Disconnect the servo motor from the machine, make sure that it operates properly, and reconnect it with the machine.

**Power on**

- 1) Switch off the servo-on signal (SON).
- 2) When power (NFB) is switched on, the display shows C (cumulative feedback pulses).



**Test operation**

In the test operation mode, make sure that the servomotor runs. (Refer to (3) in Section 2-3-3.)

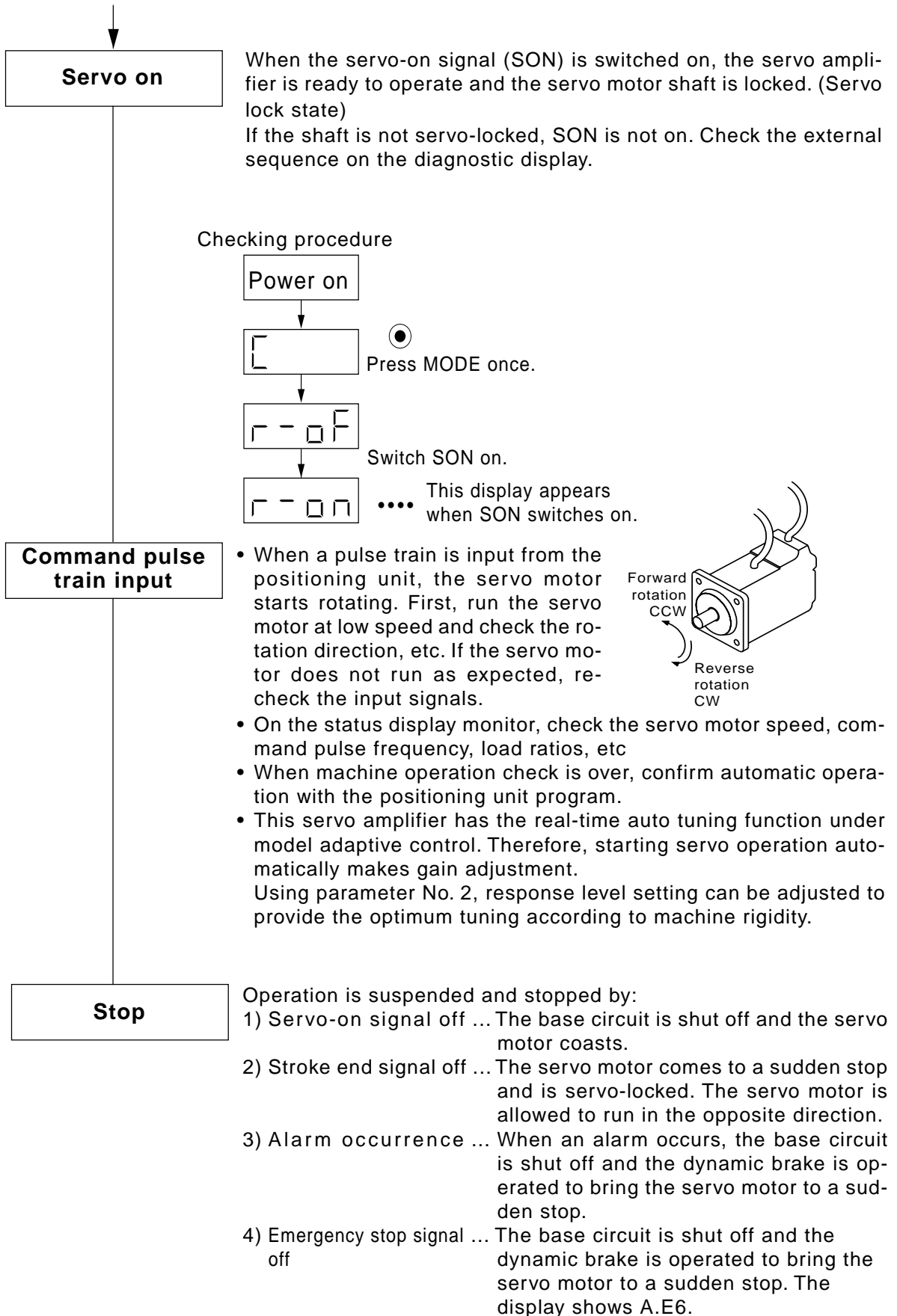
**Parameter setting**

Set the required parameters. (Refer to Section 2-3-5.)  
The servo amplifier and servo motor need not be set in parameters as they are set automatically.

• Setting example

Parameter	Set Value	Description
No.0	0 3 0 0	Control mode : Position Regenerative brake option : MR-RB12 used.
No.1	0 0 0 <input type="checkbox"/>	Electromagnetic brake interlock signal : Not used. Positioning system : Incremental
No.2	0 1 0 1	Auto tuning Response level : Low Machine : Ordinary Used or not used : Used
No.3	2	Electronic gear (CMX/CDV) : 2/1
No.4	1	

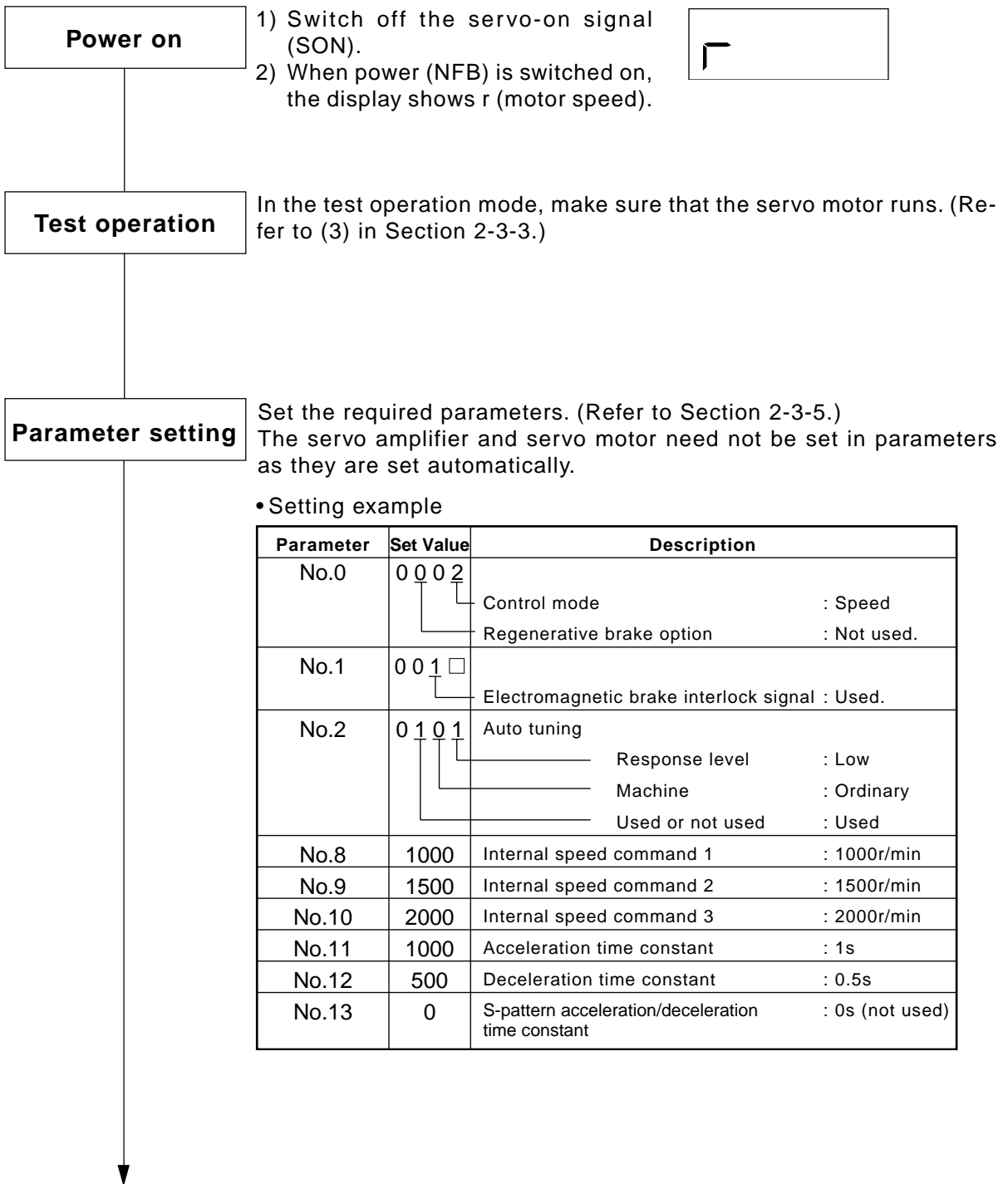
## 2. OPERATION



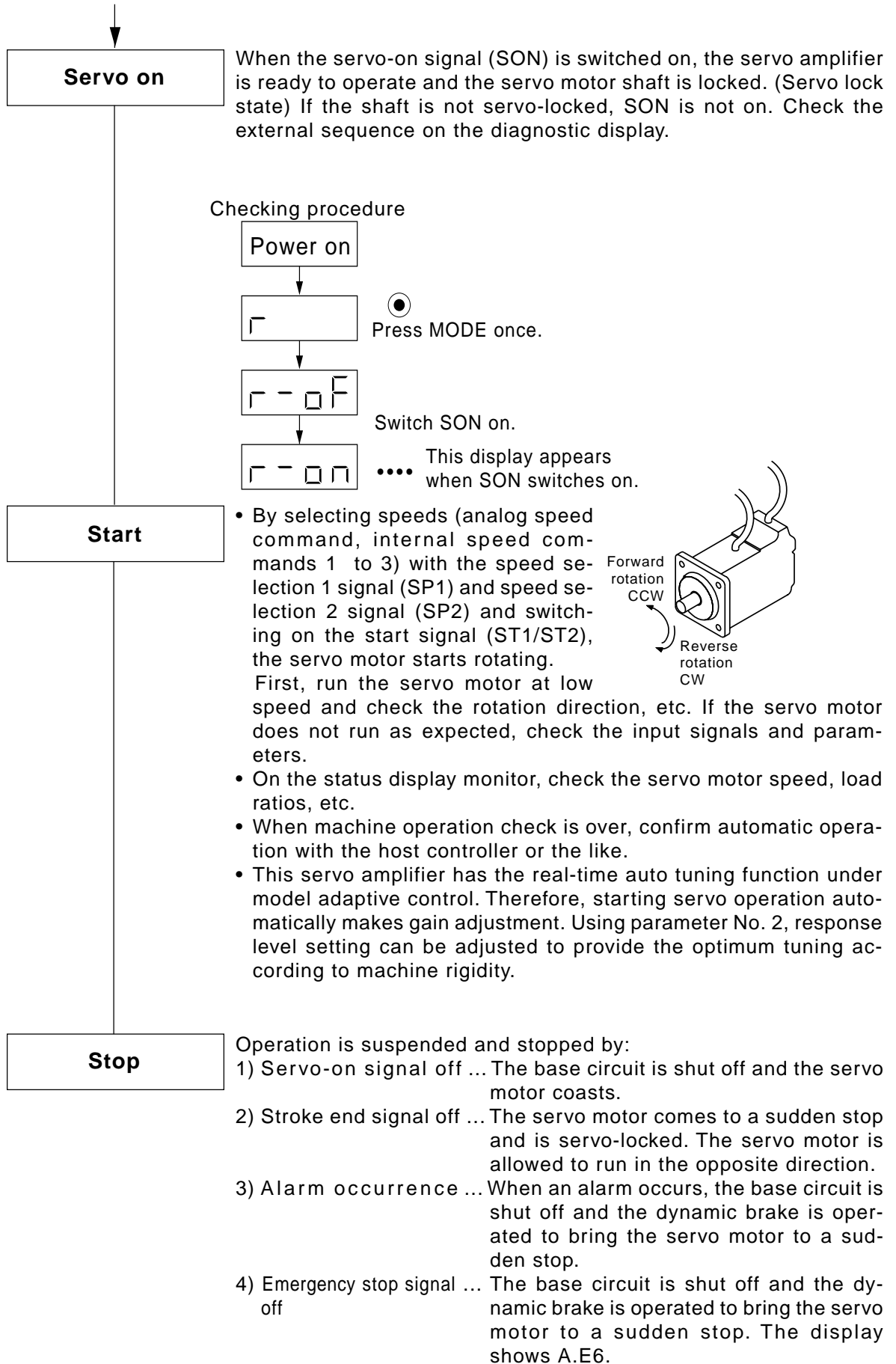
## 2. OPERATION

### (3) Speed control mode

Disconnect the servo motor from the machine, make sure that it operates properly, and reconnect it with the machine.



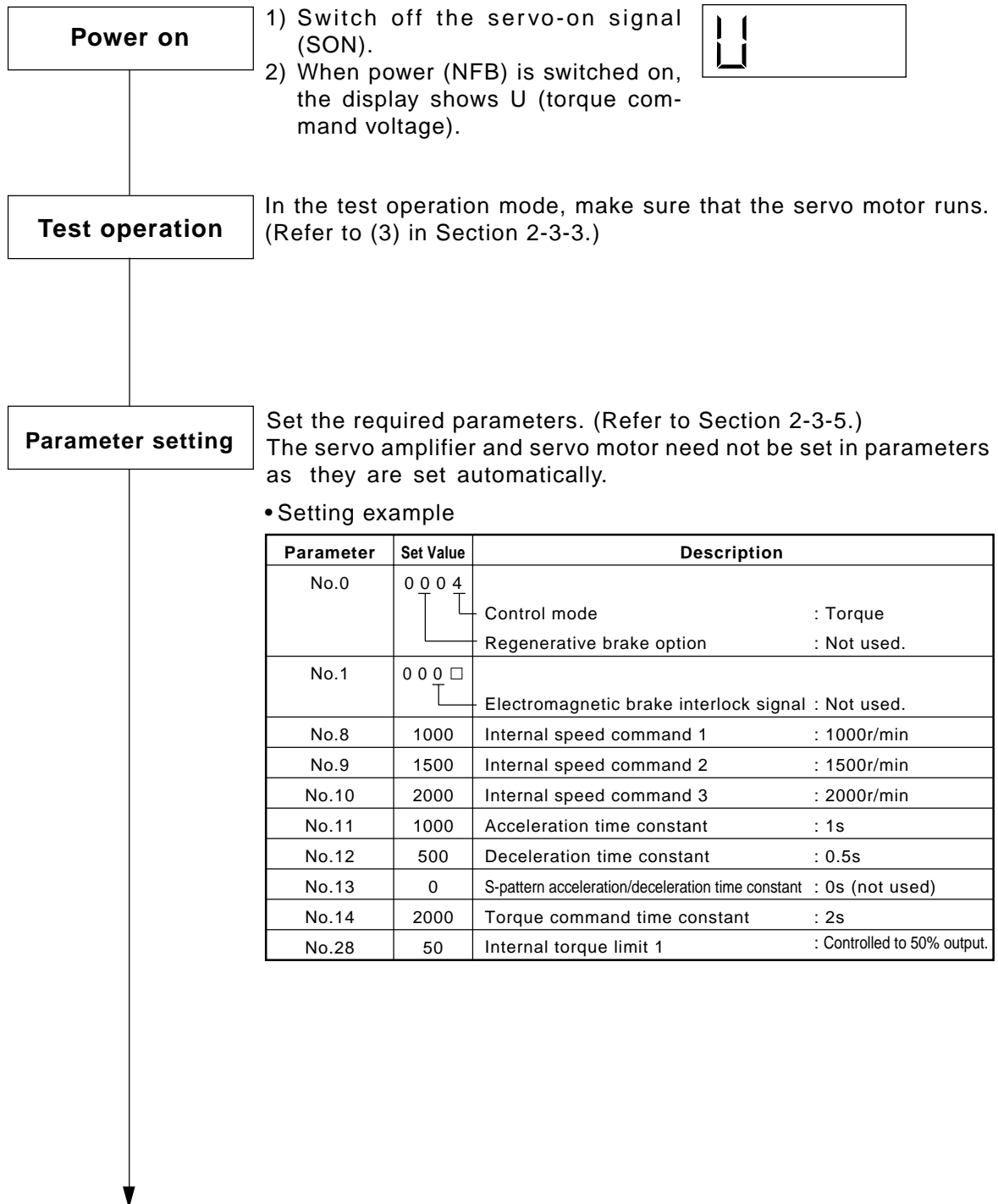
## 2. OPERATION



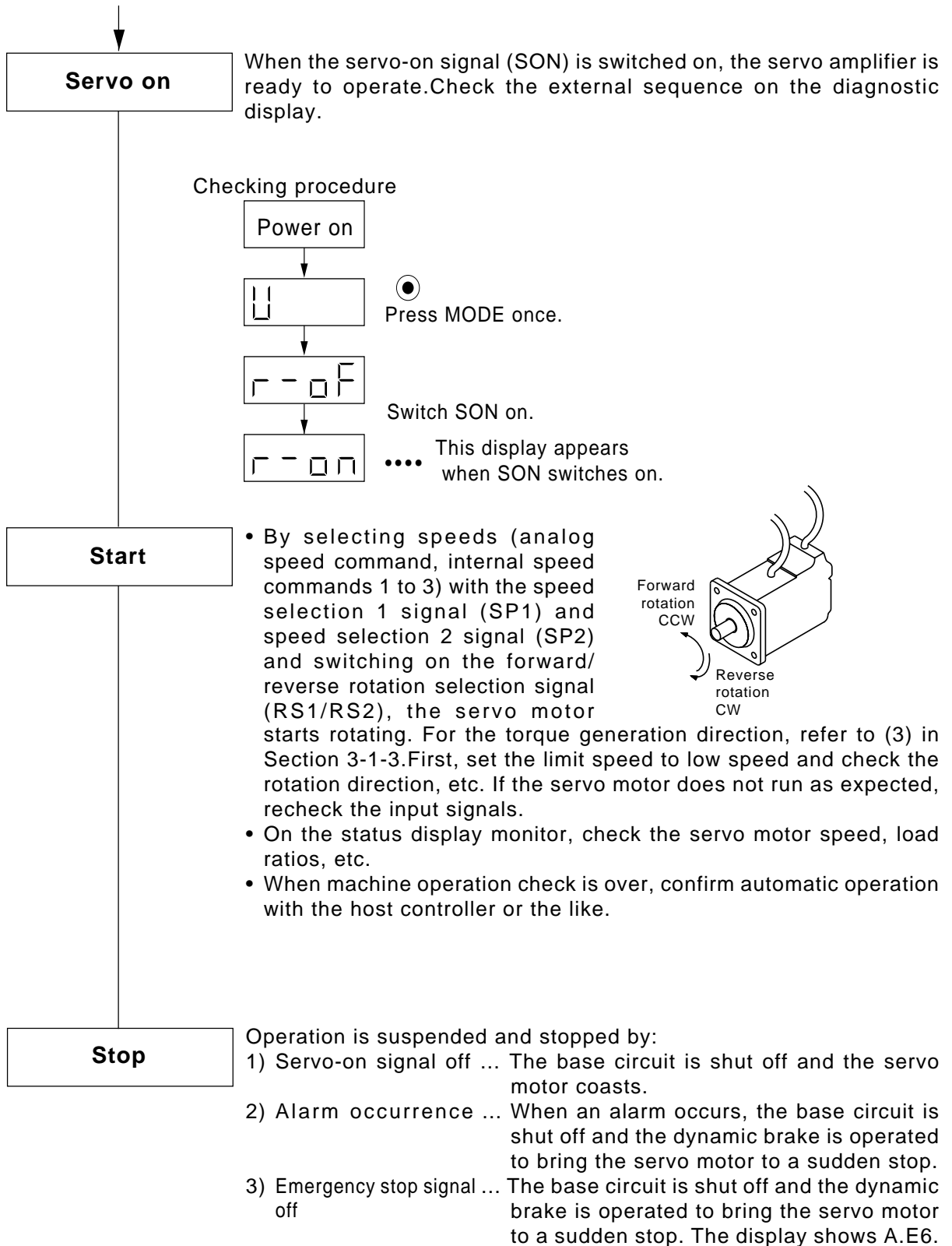
## 2. OPERATION

### (4) Torque control mode

Disconnect the servo motor from the machine, make sure that it operates properly, and reconnect it with the machine.



## 2. OPERATION



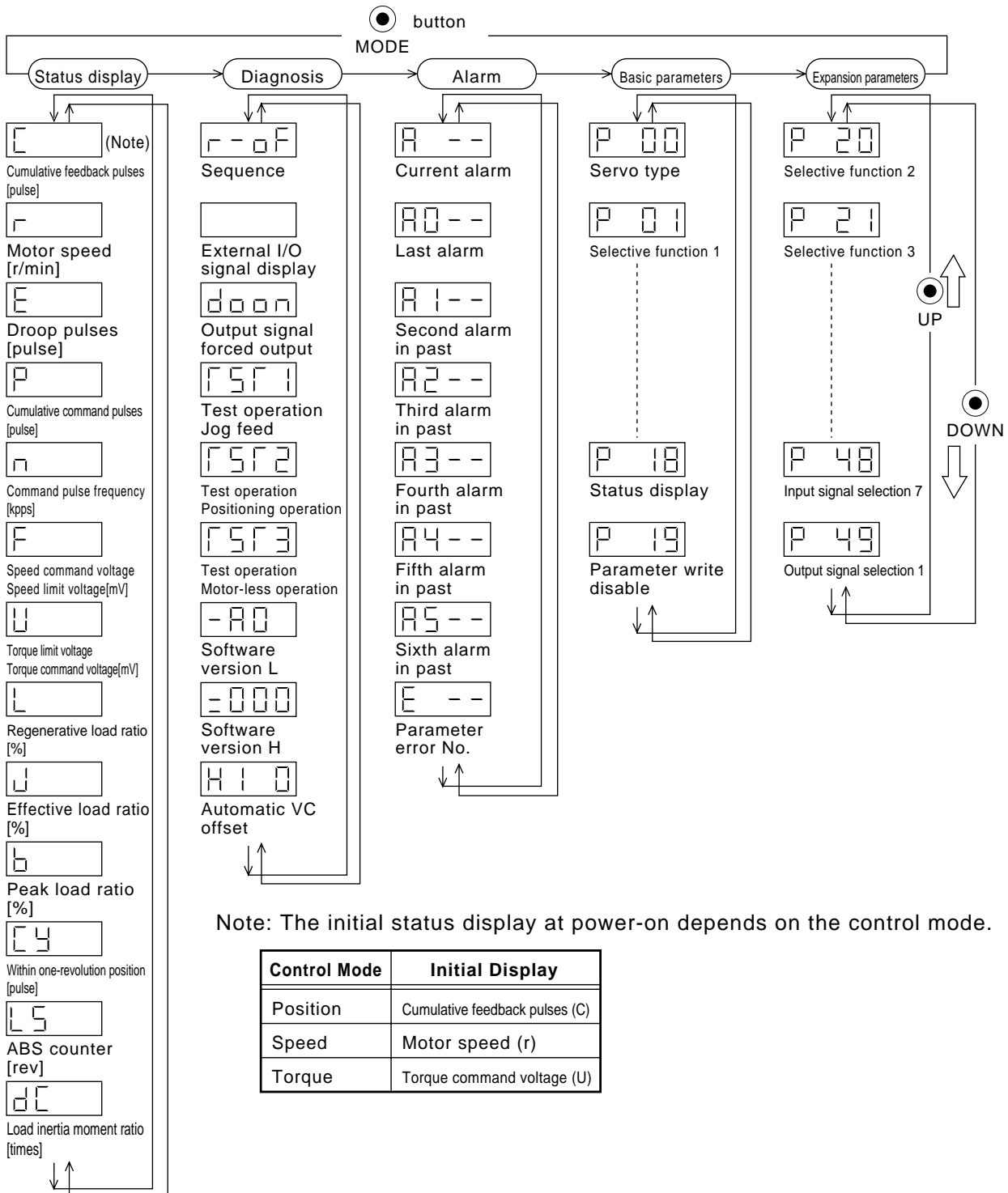
## 2. OPERATION

### 2-3 Display and operation

#### 2-3-1 Display flowchart

Use the display (4-digit, 7-segment LED) on the front panel of the servo amplifier for status display, parameter setting, etc. Set the parameters before operation, diagnose an alarm, confirm external sequences, and/or confirm the operation status. Press the **MODE**, **UP** or **DOWN** button once to move to the next screen. In the position control mode, switching power on displays the symbol C of the cumulative feedback pulses.

To refer to and/or set the expansion parameters, make them valid with parameter No. 19 (parameter write disable).






Note: The initial status display at power-on depends on the control mode.

Control Mode	Initial Display
Position	Cumulative feedback pulses (C)
Speed	Motor speed (r)
Torque	Torque command voltage (U)



## 2. OPERATION


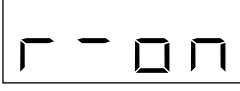
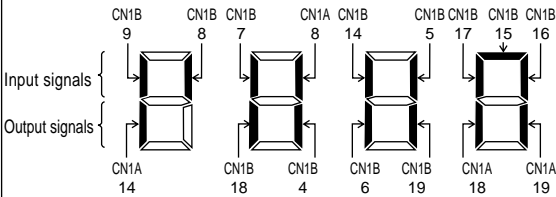







### 2-3-2 Status display

The servo status during operation is shown on the 4-digit, 7-segment LED display. Press the  or  button to change display data as desired. When the required data is selected, the corresponding symbol is displayed. Press the  button to display that data.

Name	Symbol	Display Range	Unit	Description
Cumulative feedback pulses	C	-9999 to 9999	pulse	Feedback pulses from the servo motor encoder are counted and displayed. When the value exceeds 9999, it begins with zero. Press the  button to reset the display value to zero. When the servo motor is rotating in the reverse direction, the decimal points in the upper 3 digits are lit.
Servo motor speed	r	-5400 to 5400	r/min	The servo motor speed is displayed. When the servo motor is rotating in the reverse direction, the decimal points in the upper 3 digits are lit. The value rounded off is displayed in x 0.1r/min.
Droop pulses	E	-9999 to 9999	pulse	The number of droop pulses in the deviation counter is displayed. When the value exceeds $\pm 9999$ , it begins with zero. When the servo motor is rotating in the reverse direction, the decimal points in the upper 3 digits are lit. The number of pulses to be displayed is the value obtained before it is multiplied by the electronic gear.
Cumulative command pulses	P	-9999 to 9999	pulse	The position command input pulses are counted and displayed. As this value is displayed before it is multiplied by the electronic gear (CMX/CDV), it may not match the cumulative feedback pulses. Press the  button to reset the display value to zero. When the servo motor is rotating in the reverse direction, the decimal points in the upper 3 digits are lit.
Command pulse frequency	n	-400 to 400	kpps	The frequency of the position command input pulses is displayed. This value is displayed before it is multiplied by the electronic gear (CMX/CDV). When the servo motor is rotating in the reverse direction, the decimal points in the upper 3 digits are lit.
Analog speed command voltage Analog speed limit voltage	F	-10.00 to 10.00	V	Analog speed command voltage or analog speed limit voltage is displayed. Analog speed command : -10.00 ~ +10.00V Analog speed limit : 0 ~ +10.00V
Analog torque command voltage Analog torque limit voltage	U	-10.00 to 10.00	V	Analog torque command voltage or analog torque limit voltage is displayed. Analog torque command : -10.00 ~ +10.00V Analog torque limit : 0 ~ +10.00V
Regenerative load ratio	L	0 to 100	%	The ratio of regenerative power to permissible regenerative power is displayed in %. As the permissible regenerative power depends on whether there is the regenerative brake option or not, set parameter No. 0 correctly.
Effective load ratio	J	0 to 300	%	The continuous effective load torque is displayed. When rated torque is generated, this value is 100%. The effective value for the past 15 seconds is displayed.
Peak load ratio	b	0 to 400	%	The maximum torque generated during acceleration/deceleration, etc. is displayed. When rated torque is generated, this value is 100%. The peak torque for the past 15 seconds is displayed.
Within one-revolution position	Cy	-9999 to 9999	pulse	Position within one revolution is displayed in encoder pulses. When the value exceeds 9999, it begins with 0. Counted when it is rotated counterclockwise.
ABS counter	LS	-9999 to 9999	rev	Travel value from the home position (0) in the absolute position detection system is displayed in terms of the absolute position detector's counter value.
Load inertia moment ratio	dc	0.0 to 100.0	Times	The estimated ratio of the load inertia moment to the servo motor shaft inertia moment is displayed.

## 2. OPERATION

### 2-3-3 Diagnostic mode

Name		Display	Description
Sequence			Not ready. Indicates that the servo amplifier is being initialized or an alarm has
			Ready. Indicates that the servo was switched on after completion of initialization and the servo amplifier is ready to operate.
External I/O signal display			<p>Indicates the ON-OFF states of the external I/O signals.</p> <p>The upper segments correspond to the input signals and the lower segments to the output signals.</p> <p>Lit: ON Extinguished: OFF</p>
			<p><b>NOTICE</b> The I/O signals can be changed using parameters No. 43 to 49.</p>
Output signal forced output			The digital output signal can be forced on/off. For more information, refer to (2) in this section.
Test operation mode	Jog feed		The servo motor can be jogged without pulse train input. During jog feed, the servo amplifier acts as speed control servo. The status display values of the droop pulses, cumulative command pulses and command pulse frequency do not change. For details, refer to (3) in this section.
	Positioning operation		<p><b>NOTICE</b> The set-up software (MRZJW3-SETUP31) is required for positioning operation. This operation cannot be performed from the operation section of the servo amplifier.</p> <p>The servo motor can be positioned without pulse train input.</p>
	Motor-less operation		Without connection of the servo motor, the servo amplifier provides output signals and displays the status as if the servo motor is running actually in response to the external input signal. This function can be used to make a sequence check on the host positioning unit, etc. For more information, refer to 2), (3) in this section.
Software version Low			Indicates the version of the software.
Software version High			Indicates the system number of the software.
Automatic VC offset			<p>If offset voltages in the analog circuits inside and outside the servo amplifier cause the servo motor to rotate slowly at the analog speed command (VC) or analog speed limit (VLA) of 0V, this function automatically makes zero-adjustment of offset voltages. Press <math>\text{SET}</math> once, set the first digit numerical value to 1 using the button <math>\text{UP}</math> or <math>\text{DOWN}</math>, and press <math>\text{SET}</math> again to make the automatic VC offset function valid. When this function is executed, the automatically offset value is set to parameter No. 29.</p> <p>If the input voltage of VC or VLA is <math>\pm 0.4\text{V}</math> or higher, this function cannot be used.</p>

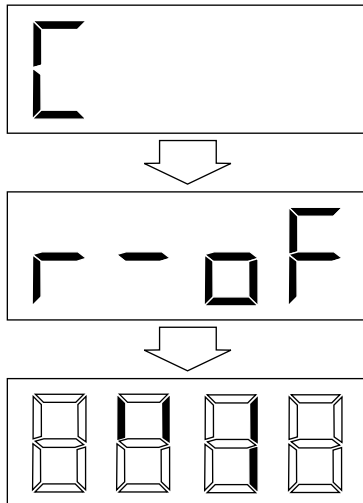
## 2. OPERATION

### (1) External I/O signal display

The ON/OFF states of the digital I/O signals connected to the servo amplifier can be confirmed.

#### 1) Operation

Call the display screen shown after power-on.

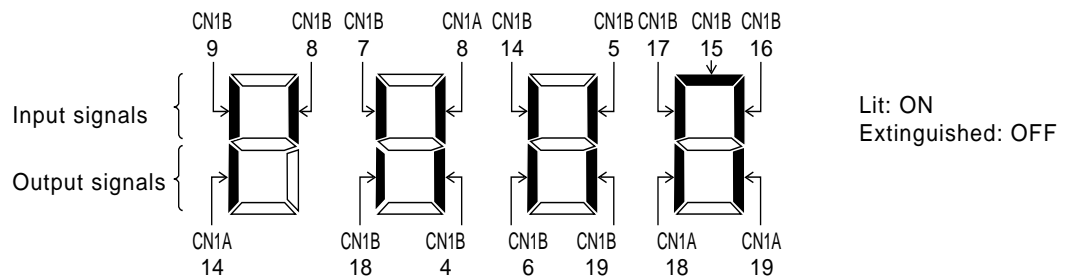


 Press MODE once.

 Press UP once.

..... External I/O signal display screen

#### 2) Display definition



The 7-segment LED shown above indicates ON/OFF.

Each segment at top indicates the input signal and each segment at bottom indicates the output signal. The signals corresponding to the pins in the respective control modes are indicated below:

## 2. OPERATION

### a. Control modes and I/O signals

Connector	Pin No.	Signal Input/Output (Note 1) I/O	(Note 2) Symbols of I/O Signals in Control Modes					
			P	P/S	S	S/T	T	T/P
CN1A	8	I	CR	CR/SP1	(Note 3)SP1	SP1	(Note 3)SP1	SP1/CR
	14	O	OP	OP	OP	OP	OP	OP
	(Note 6,8)18	O	INP	INP/SA	SA	SA/×		×/INP
	(Note 8)19	O	RD	RD	RD	RD	RD	RD
CN1B	(Note 9)4	O	DO1	DO1	DO1	DO1	DO1	DO1
	(Note 7)5	I	SON	SON	SON	SON	SON	SON
	(Note 6)6	O	TLC	TLC	TLC	TLC/VLC	VLC	VLC/TLC
	(Note 7)7	I		LOP	SP2	LOP	SP2	LOP
	(Note 7)8	I	PC	PC/ST1	(Note 4)ST1	ST1/RS2	(Note 4)RS2	RS2/PC
	(Note 7)9	I	TL	TL/ST2	(Note 5)ST2	ST2/RS1	(Note 5)RS1	RS1/TL
	(Note 7)14	I	RES	RES	RES	RES	RES	RES
	15	I	EMG	EMG	EMG	EMG	EMG	EMG
	16	I	LSP	LSP	LSP	LSP/×		×/LSP
	17	I	LSN	LSN	LSN	LSN/×		×/LSN
	(Note 6)18	O	ALM	ALM	ALM	ALM	ALM	ALM
	(Note 6, 8)19	O	ZSP	ZSP	ZSP	ZSP	ZSP	ZSP

Note: 1. I: Input signal, O: Output signal

2. P: Position control mode, S: Speed control mode, T: Torque control mode, P/S: Position/speed control change mode, S/T: Speed/torque control change mode, T/P: Torque/position control change mode

3. Set parameter No. 45 to use CR.

4. Set parameter No. 47 to use PC.

5. Set parameter No. 48 to use TL.

6. Set parameter No. 49 to use WNG and BWNG.

7. Set parameters No. 43 to 48 to change signals.

8. Set parameter No. 49 to output the alarm code. (Refer to Chapter 8.)

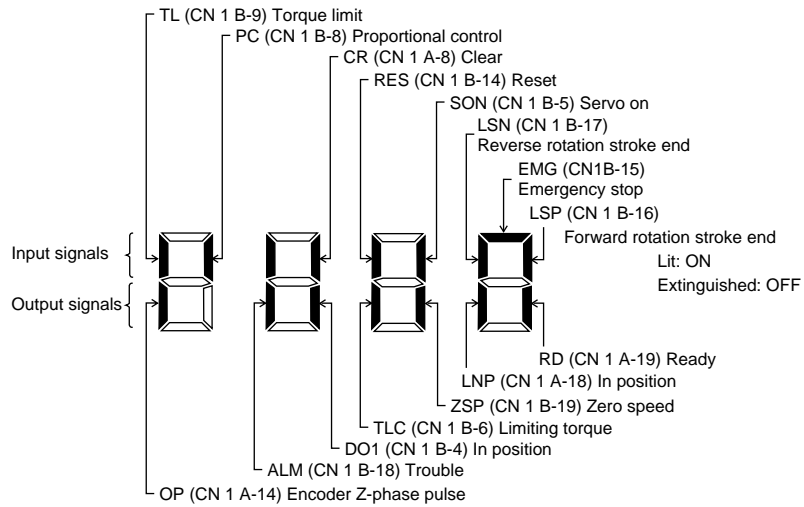
9. The signal of CN1A-18 is always output.

### b. Symbols and signal names

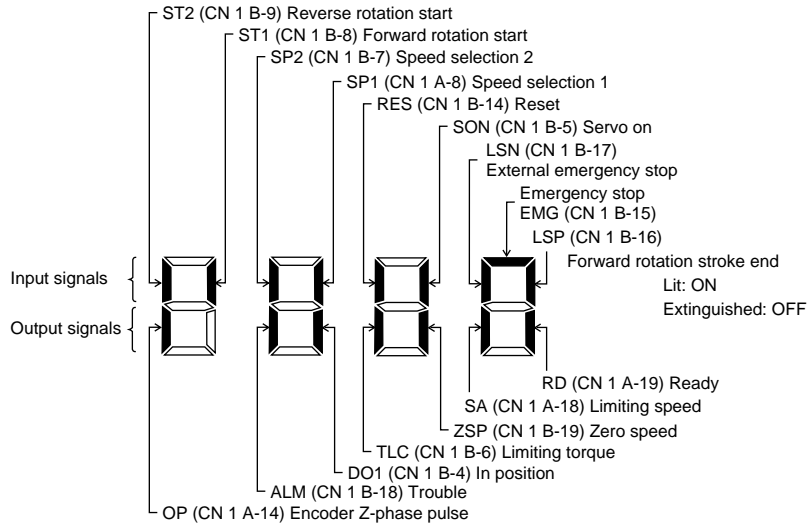
Symbol	Signal Name	Symbol	Signal Name
SON	Servo on	EMG	Emergency stop
LSP	Forward rotation stroke end	LOP	Control change
LSN	Reverse rotation stroke end	TLC	Limiting torque
CR	Clear	VLC	Limiting speed
SP1	Speed selection 1	RD	Ready
SP2	Speed selection 2	ZSP	Zero speed
PC	Proportion control	INP	In position
ST1	Forward rotation start	SA	Speed reached
ST2	Reverse rotation start	ALM	Trouble
RS1	Forward rotation selection	WNG	Warning
RS2	Reverse rotation selection	OP	Encoder Z-phase pulse (open collector)
TL	Torque limit	BWNG	Battery warning
RES	Reset		

## 2. OPERATION

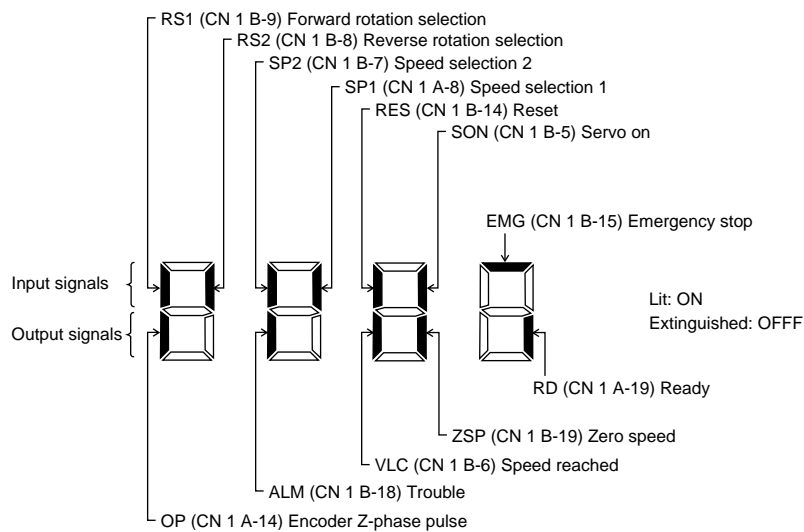
### 3) Default signal indications a. Position control mode



### b. Speed control mode



### c. Torque control mode



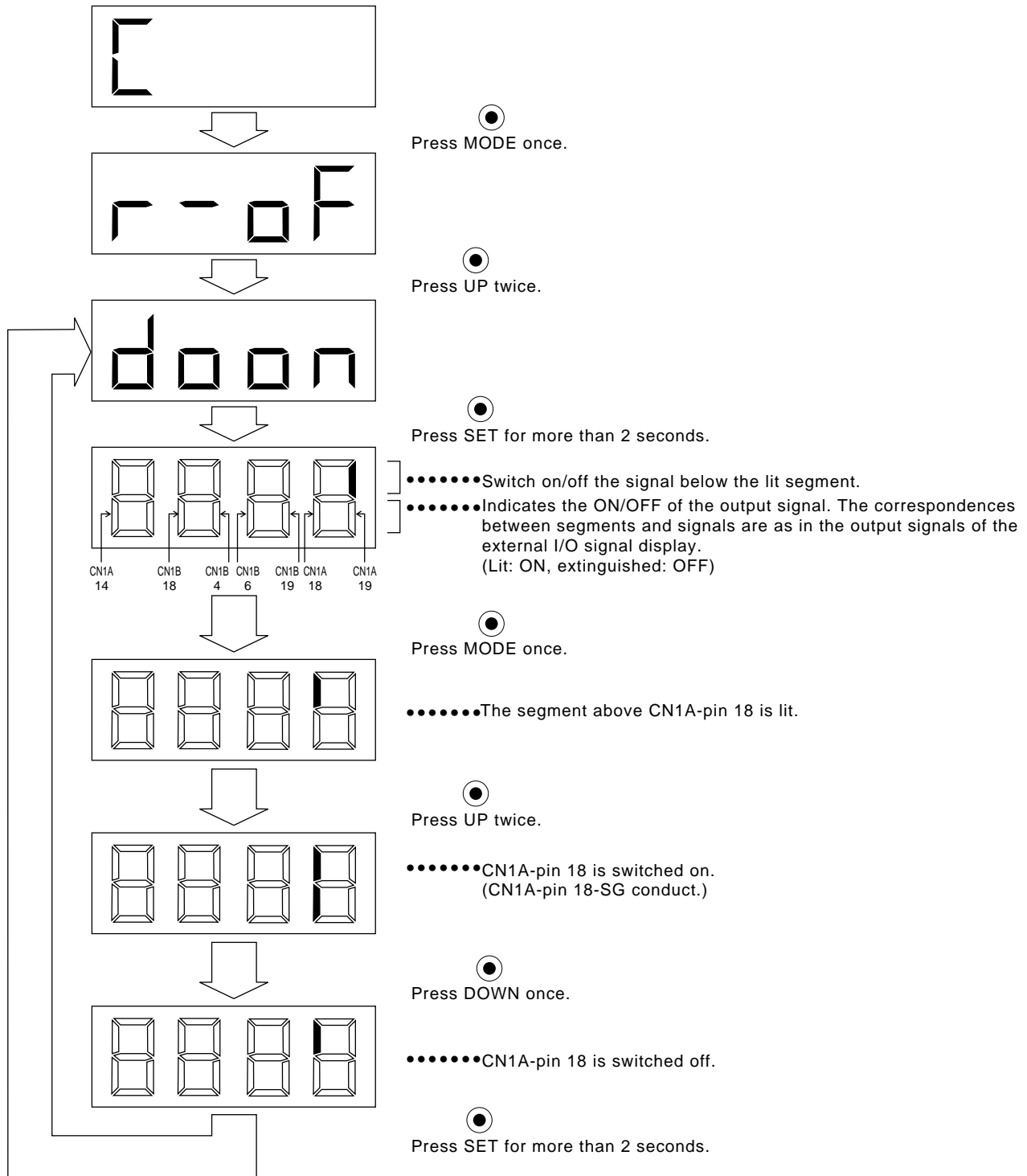
## 2. OPERATION

### (2) Output signal forced output

The output signal can be forced on/off independently of the servo status. This function is used for output signal wiring check, etc. This operation must be performed in the servo off state (SON signal off).

#### Operation

Call the display screen shown after power-on.



## 2. OPERATION

### (3) Test operation mode

#### ⚠ CAUTION

1. The test operation mode is designed to confirm servo operation and not to confirm machine operation. In this mode, do not use the servo motor with the machine. Always use the servo motor alone.
2. If any operational fault has occurred, stop operation using the emergency stop (EMG) signal.

#### MEMORANDUM

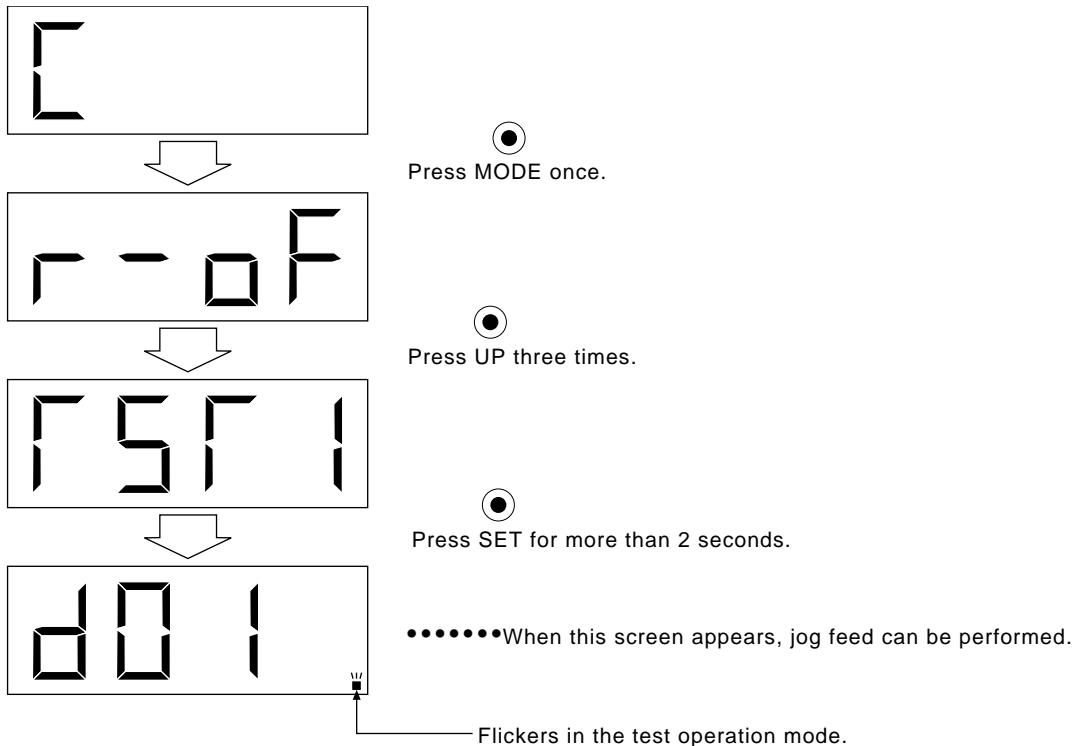
This mode cannot be used for the absolute position detection system. Set parameter No. 1 to select the incremental positioning system.

#### 1) Jog feed

Jog feed can be performed without pulse train input from a command unit or the like.

##### a. Mode change

Call the display screen shown after power-on.



##### b. Starting method

Perform the following operation to rotate the servo motor at 200r/min. At this time, the acceleration/deceleration time constant is 1s. When performing jog feed, connect EMG-SG and VDD-COM (when internal power supply is used).

Rotation Direction	Operation
CCW	Press
CW	Press

To stop, release the corresponding button.

##### c. Status display

Press to display the servo status during test operation. The display data is the same as in the status display in Section 2-3-2.

##### d. Termination of jog feed

To terminate the jog feed, switch power off once or call the screen using and press for more than 2s.

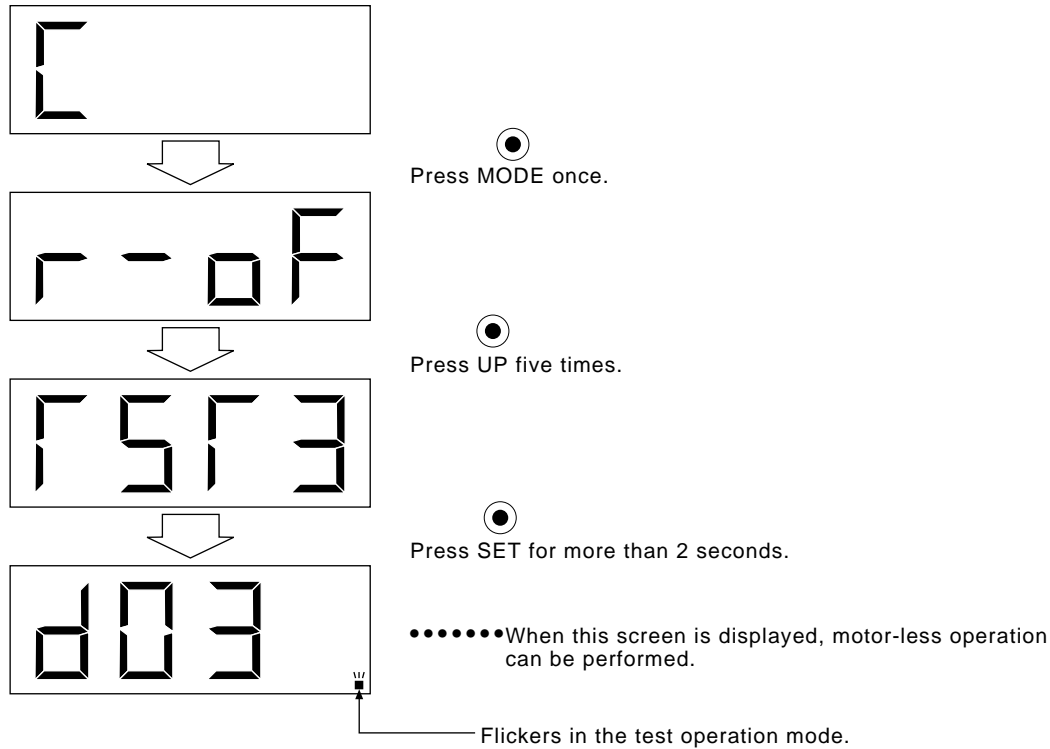
## 2. OPERATION

### 2) Motor-less operation

Without connection of the servo motor, the servo amplifier can provide output signals and display the status as if the servo motor is running actually in response to the external input signal. This function can be used to make a sequence check on the host positioning unit, etc. Switch off the servo-on signal.

#### a. Mode change

Call the display screen shown after power-on.



#### b. Operation method

As in ordinary operation, provide the start signal.

#### c. Status display

Press **MODE** to shift to the status display screen, on which the status of servo motor rotation is indicated in simulative value. The display data is the same as in the status display in Section 2-3-2.

#### d. Termination of motor-less operation

To terminate the motor-less operation, switch power off.




## 2. OPERATION

### 2-3-4 Alarm mode

The current alarm, past alarm history and parameter error are displayed. The lower 2 digits on the display indicate the alarm number that has occurred or the parameter number in error. Display examples are shown below.

Name	Display	Description
Current alarm	A --	Indicates no occurrence of an alarm.
	A. 33	Indicates the occurrence of alarm 33 (overvoltage). Flickers at occurrence of the alarm.
Alarm history	A050	Indicates that the last alarm is alarm 50 (overload 1).
	A 133	Indicates that the second alarm in the past is alarm 33 (overvoltage).
	A2 10	Indicates that the third alarm in the past is alarm 10 (undervoltage).
	A33 1	Indicates that the fourth alarm in the past is alarm 31 (overspeed).
	A4 --	Indicates that there is no fifth alarm in the past.
	A5 --	Indicates that there is no sixth alarm in the past.
Parameter error	E. --	Indicates no occurrence of alarm 37 (parameter error).
	E. 0 1	Indicates that the data of parameter No. 1 is faulty.

#### Functions at occurrence of an alarm

- (1) Any mode screen displays the current alarm.
- (2) The other screen is visible during occurrence of an alarm. At this time, the decimal point in the fourth digit flickers.
- (3) To clear any alarm, switch power off, then on or press the  button on the current alarm screen. Note that this should be done after removing the cause of the alarm.
- (4) Use parameter No. 16 to clear the alarm history.

## 2. OPERATION

### 2-3-5 Parameter mode

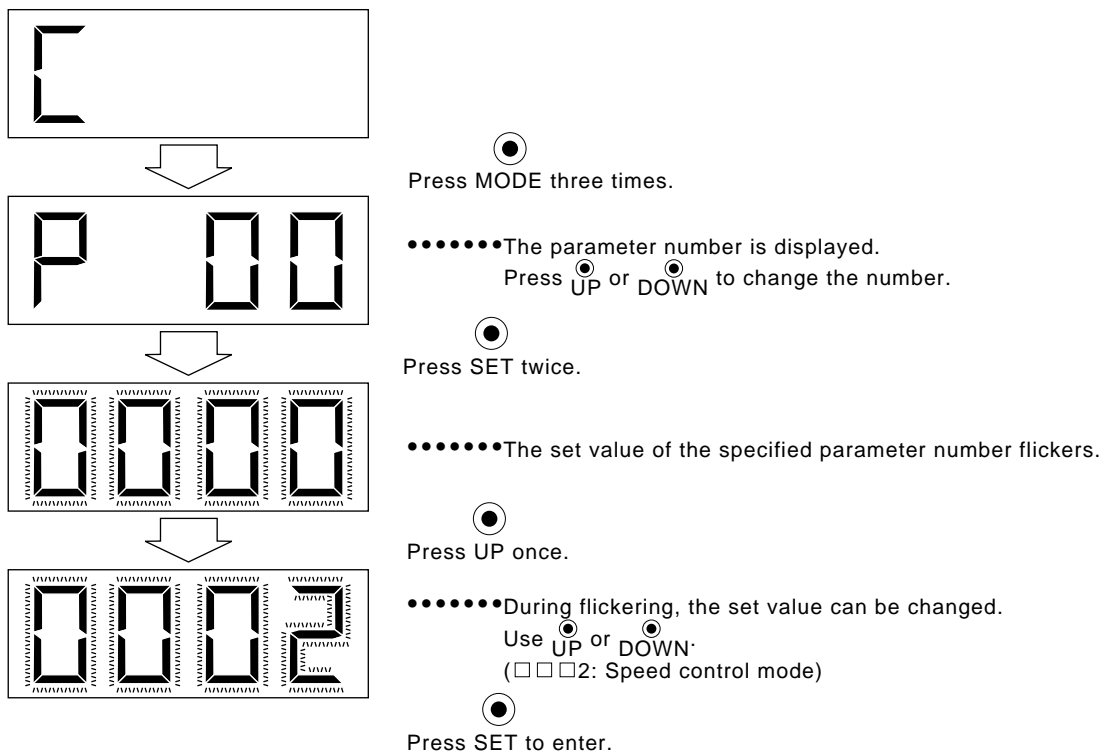
The servo amplifier is factory-set in the position control mode. Change the parameter settings when:

- 1) The control mode is changed;
- 2) The regenerative brake option is used;
- 3) The number of pulses per servo motor revolution is changed  
(When the number of pulses per servo motor revolution has been set to the position command unit, set the number of pulses in the parameter of the position command unit unless the maximum number of pulses is restricted); or
- 4) The machine mounted with the servo motor hunts or operational performance is further improved.

#### (1) Operation example

##### 1) 4-digit parameter

The following example shows the operation procedure performed after power-on to place the servo in the speed control mode:



To shift to the next parameter, press the UP/DOWN button.

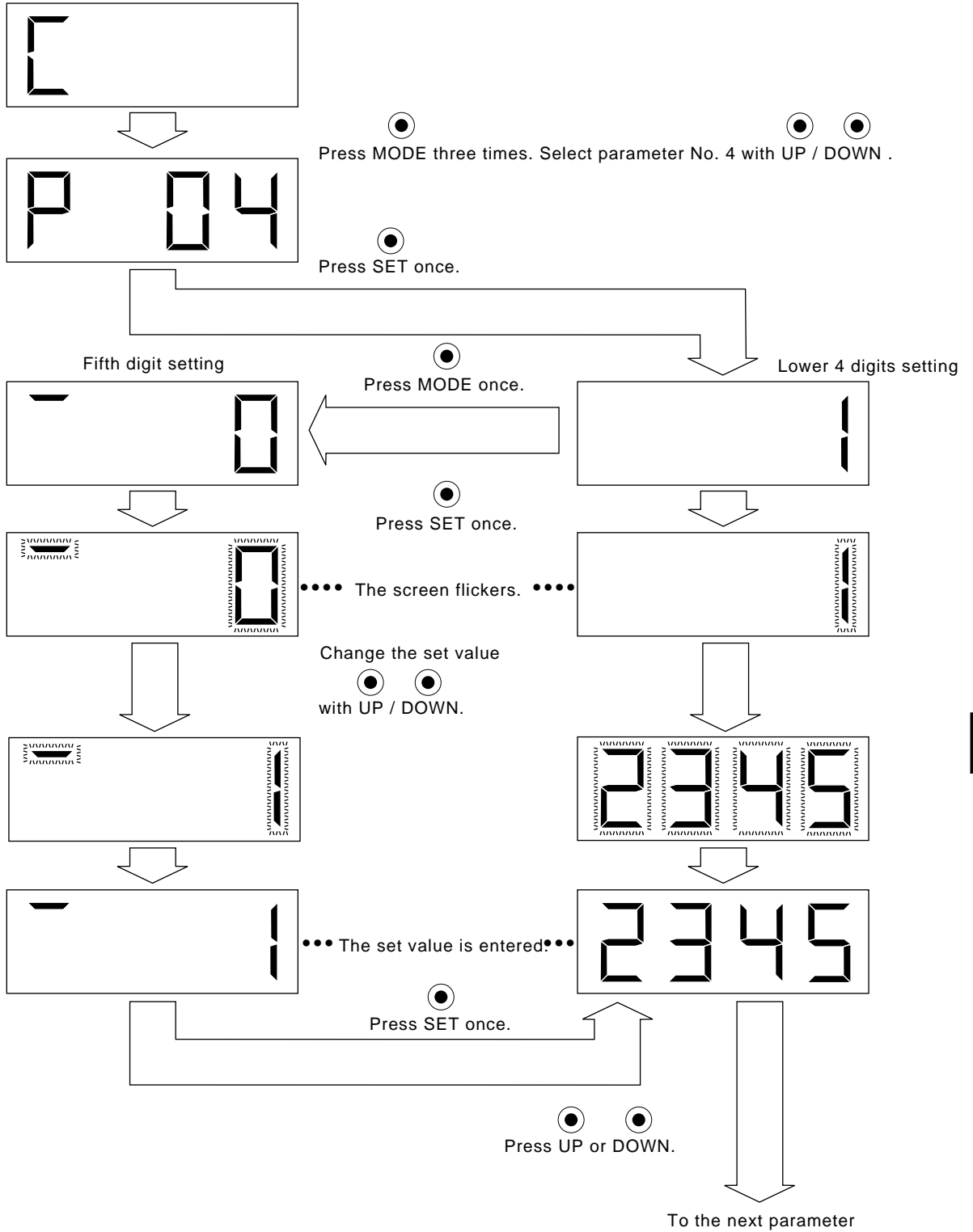
When changing the parameter No. 0 setting, change its set value, then switch power off once and switch it on again to make the new value valid.

## 2. OPERATION

### 2) 5-digit parameter

The following example shows the operation procedure performed to change the electronic gear denominator (parameter No. 4) into "12345":

Call the display screen shown after power-on.



## 2. OPERATION

---

### (2) Expansion parameters

To use the expansion parameters, change the setting of parameter No. 19 (parameter write disable). After setting parameter No. 19, switch power off once, then switch it on again to make the parameter valid.

The table below shows the parameters referenced and write enabled by the setting of parameter No. 19. Those parameters marked ○ can be operated.

Set Value	Operation	Basic Parameters No.0-19	Expansion Parameters No.20-49
0000 (initial value)	Reference	○	
	Write	○	
000A	Reference	Allowed for No. 19 only	
	Write	Allowed for No. 19 only	
000B	Reference	○	○
	Write	○	
000C	Reference	○	○
	Write	○	○

## 2. OPERATION

### (3) Parameter list

For any parameter whose symbol is preceded by \*, set the parameter and switch power off once, then switch it on again to make that parameter valid.

The symbols in the Control Mode field represent parameters used in the corresponding modes. (P: Position control mode, S: Speed control mode, T: Torque control mode)

No.	Symbol	Name	Control Mode	Initial Value	Unit	Customer Setting
Basic parameters	0	*STY	Control mode, regenerative brake option selection	P • S • T	0000	
	1	*OP1	Function selection 1	P • S • T	0002	
	2	ATU	Auto tuning	P • S	0102	
	3	CMX	Electronic gear (Command pulse multiplying factor numerator)	P	1	
	4	CDV	Electronic gear (Command pulse multiplying factor denominator)	P	1	
	5	INP	In-position range	P	100	pulse
	6	PG1	Position loop gain 1	P	36	rad/s
	7	PST	Position command acceleration/deceleration time constant (Position smoothing)	P	3	ms
	8	SC1	Internal speed command 1	S	100	r / min
			Internal speed limit 1	T	100	r / min
	9	SC2	Internal speed command 2	S	500	r / min
			Internal speed limit 2	T	500	r / min
	10	SC3	Internal speed command 3	S	1000	r / min
			Internal speed limit 3	T	1000	r / min
	11	STA	Acceleration time constant	S • T	0	ms
	12	STB	Deceleration time constant	S • T	0	ms
	13	STC	S-pattern acceleration/deceleration time constant	S • T	0	ms
	14	TQC	Torque command time constant	T	0	ms
	15		For manufacture setting		0	
16	*BPS	Communication baudrate selection, alarm history clear	P • S • T	0000		
17	MOD	Analog monitor output	P • S • T	0100		
18	*DMD	Status display selection	P • S • T	0000		
19	*BLK	Parameter block	P • S • T	0000		

## 2. OPERATION

No.	Symbol	Name	Control Mode	Initial Value	Unit	Customer Setting	
Expansion parameters	20	*OP2	Function selection 2	P • S • T	0000		
	21	*OP3	Function selection 3 (Command pulse selection)	P	0000		
	22	*OP4	Function selection 4	P • S • T	0000		
	23	FFC	Feed forward gain	P	0	%	
	24	ZSP	Zero speed	P • S • T	50	r/min	
	25	VCM	Analog speed command maximum speed	S	(Note1)0	(r/min)	
			Analog speed limit maximum speed	T	(Note1)0	(r/min)	
	26	TLC	Analog torque command maximum output	T	100	%	
	27	*ENR	Encoder output pulses	P • S • T	4000	pulse	
	28	TL1	Internal torque limit 1	P • S • T	100	%	
	29	VCO	Analog speed command offset	S	(Note2)	mV	
			Analog speed limit offset	T	(Note2)	mV	
	30	TLO	Analog torque command offset	T	0	mV	
			Analog torque limit offset	S	0	mV	
	31	MO1	Analog monitor offset 1	P • S • T	0	mV	
	32	MO2	Analog monitor offset 2	P • S • T	0	mV	
	33	MBR	Electromagnetic brake sequence output	P • S • T	100	ms	
	34	GD2	Ratio of load inertia moment to servo motor inertia moment	P • S	70	0.1 times	
	35	PG2	Position loop gain 2	P	30	rad/s	
	36	VG1	Speed loop gain 1	P • S	216	rad/s	
	37	VG2	Speed loop gain 2	P • S	714	rad/s	
	38	VIC	Speed integral compensation	P • S	20	ms	
	39	VDC	Speed differential compensation	P • S	980		
	40		For manufacturer setting		0		
	41	*DIA	Input signal automatic ON selection	P • S • T	0000		
	42	*DI1	Input signal selection 1	P • S • T	0003		
	43	*DI2	Input signal selection 2 (CN1B-pin 5)	P • S • T	0111		
	44	*DI3	Input signal selection 3 (CN1B-pin 14)	P • S • T	0222		
	45	*DI4	Input signal selection 4 (CN1A-pin 8)	P • S • T	0665		
46	*DI5	Input signal selection 5 (CN1B-pin 7)	P • S • T	0770			
47	*DI6	Input signal selection 6 (CN1B-pin 8)	P • S • T	0883			
48	*DI7	Input signal selection 7 (CN1B-pin 9)	P • S • T	0994			
49	*DO1	Output signal selection 1	P • S • T	0000			

Note: 1. 0: Rated servo motor speed  
2. Depends on the servo amplifier.

## 2. OPERATION

### (4) Detailed explanation of the parameters

To make the parameter marked \* valid, set the parameter and switch power off once, then switch it on again.

The symbols in the Control Mode field represent parameters used in the corresponding modes. (P: Position control mode, S: Speed control mode, T: Torque control mode)

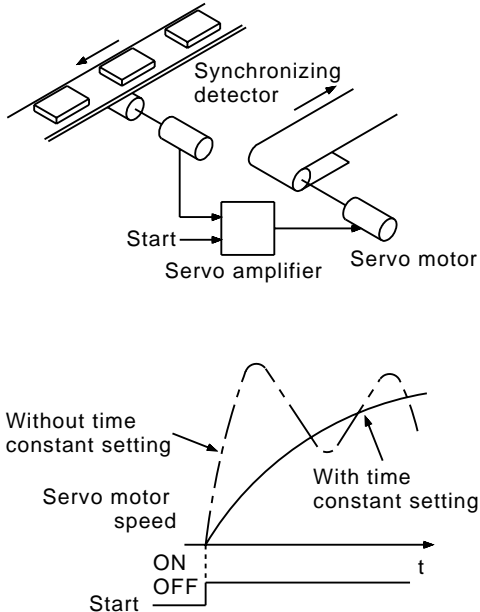
Class	No.	Symbol	Name and Function	Initial Value	Unit	Setting Range	Control Mode				
Basic parameters	0	*STY	<p>Control mode, regenerative brake option selection</p> <p>Used to select the control mode and regenerative brake option.</p> <table border="1" style="margin-left: 20px;"> <tr> <td style="width: 20px; text-align: center;">0</td> <td style="width: 20px;"></td> <td style="width: 20px; text-align: center;">0</td> <td style="width: 20px;"></td> </tr> </table> <p style="margin-left: 40px;">Select the control mode.</p> <p style="margin-left: 40px;">0: Position 1: Position and speed 2: Speed 3: Speed and torque 4: Torque 5: Torque and position</p> <p style="margin-left: 40px;">Select the regenerative brake option.</p> <p style="margin-left: 40px;">0: Not used 1: Reserved (do not set) 2: MR – RB032 3: MR – RB12 4: MR – RB32 5: MR – RB30 6: MR – RB50</p> <div style="border: 1px solid black; padding: 5px; margin-top: 10px;"> <p><b>NOTICE</b> Wrong setting may cause the regenerative brake option to burn.</p> </div> <div style="border: 1px solid black; padding: 5px; margin-top: 5px;"> <p><b>MEMORANDUM</b> If the regenerative brake option selected is not for use with the servo amplifier, parameter error (A. 37) occurs.</p> </div>	0		0		0000		0000h to 0605h	P • S • T
	0		0								
1	*OP1	<p>Function selection 1:</p> <p>Used to select the input signal filter, CN1B-pin 19's output signal and absolute position detection system.</p> <table border="1" style="margin-left: 20px;"> <tr> <td style="width: 20px;"></td> <td style="width: 20px; text-align: center;">0</td> <td style="width: 20px;"></td> <td style="width: 20px;"></td> </tr> </table> <p style="margin-left: 40px;">Input signal filter</p> <p style="margin-left: 40px;">0: None 1: 1.77ms 2: 3.55ms</p> <p style="margin-left: 40px;">CN1B-pin 19's function selection</p> <p style="margin-left: 40px;">0: Zero speed detection signal 1: Electromagnetic brake interlock signal</p> <p style="margin-left: 40px;">Positioning system</p> <p style="margin-left: 40px;">0: Used in incremental positioning system 1: Used in absolute position detection system</p>		0			0002		0000h to 1012h	<p>P • S • T</p> <hr style="border-top: 1px dashed black;"/> <p>P</p>	
	0										

## 2. OPERATION

Class	No.	Symbol	Name and Function	Initial Value	Unit	Setting Range	Control Mode												
Basic parameters	2	ATU	<p>Auto tuning: Used to set the response level, etc. for execution of auto tuning.</p> <div style="border: 1px solid black; width: 100px; height: 20px; display: flex; align-items: center; justify-content: center;">0</div> <p style="margin-left: 100px;">Auto tuning response level setting</p> <table border="1" style="margin-left: 100px;"> <thead> <tr> <th>Set Value</th> <th>Response Level</th> </tr> </thead> <tbody> <tr> <td>1</td> <td>Low response</td> </tr> <tr> <td>2</td> <td>to</td> </tr> <tr> <td>3</td> <td>Middle response</td> </tr> <tr> <td>4</td> <td>to</td> </tr> <tr> <td>5</td> <td>High response</td> </tr> </tbody> </table> <ul style="list-style-type: none"> <li>If the machine hunts or generates large gear sound, decrease the set value.</li> <li>To improve performance, e.g. shorten the settling time, increase the set value.</li> </ul> <p style="margin-left: 100px;">Select the machine. For example, used to improve the position settling characteristic when friction is large. 0: Normal 1: Friction is large</p> <p style="margin-left: 100px;">Auto tuning selection 0: Interpolation axis control(speed loop only) 1: Executed for both position and speed loops 2: No.</p>	Set Value	Response Level	1	Low response	2	to	3	Middle response	4	to	5	High response	0102		0001h to 0215h	P • S
	Set Value	Response Level																	
1	Low response																		
2	to																		
3	Middle response																		
4	to																		
5	High response																		
3	CMX	<p>Electronic gear (Command pulse multiplying factor numerator): Used to set the multiplier of the command pulse input.</p> <div style="margin-left: 20px;"> <math display="block">\text{Command pulse input } f_1 \rightarrow \frac{\text{CMX}}{\text{CDV}} \rightarrow \text{Position command } f_2 = f_1 \cdot \frac{\text{CMX}}{\text{CDV}}</math> </div> <p>Note: Set in the range of <math>1/50 &lt; \frac{\text{CMX}}{\text{CDV}} &lt; 50</math>.</p> <p>The setting of the number of input pulses per servo motor revolution can be changed by the following formula:HC-MF series: 8192 pulses/rev)</p> $8192 \cdot \frac{\text{CDV}}{\text{CMX}} \text{ [pulse/rev]}$ <div style="border: 1px solid black; padding: 5px; margin-top: 10px;"> <p> <b>CAUTION</b> Wrong setting will rotate the servo motor at unexpectedly high speed, leading to injury.</p> </div>	1		1 to 32767	P													



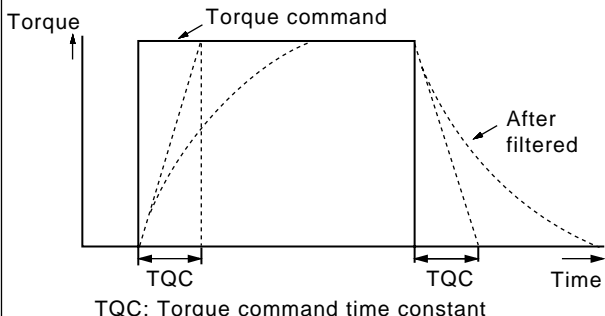
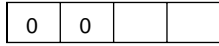
## 2. OPERATION

Class	No.	Symbol	Name and Function	Initial Value	Unit	Setting Range	Control Mode
Basic parameters	4	CDV	Electronic gear (Command pulse multiplying factor denominator): Used to set the divisor of the command pulse input.	1		1 to 32767	P
	5	INP	In-position range: Used to set the droop pulse range in which the in-position (INP) signal will be output.	100	pulse	0 to 10000	P
	6	PG1	Position loop gain 1: Used to set the gain of position loop 1. Increase the gain to improve trackability in response to the position command.	36	rad/s	4 to 1000	P
	7	PST	Position command acceleration/deceleration time constant (Position smoothing): Used to set the time constant of a low pass filter in response to the position command. Example: When a command is given from a synchronizing detector, synchronous operation can be started smoothly if started during line operation.  	3	ms	0 to 20000	P
8	SC1	Internal speed command 1: Used to set speed 1 of internal speed commands.	100	r/min	0 to instantaneous permissible speed	S	
		Internal speed limit 1: Used to set speed 1 of internal speed limits.				T	
9	SC2	Internal speed command 2: Used to set speed 2 of internal speed commands.	500	r/min	0 to instantaneous permissible speed	S	
		Internal speed limit 2: Used to set speed 2 of internal speed limits.				T	


## 2. OPERATION

Class	No.	Symbol	Name and Function	Initial Value	Unit	Setting Range	Control Mode
Basic parameters	10	SC3	Internal speed command 3: Used to set speed 3 of internal speed commands.	1000	r/min	0 to instantaneous permissible speed	S
			Internal speed limit 3: Used to set speed 3 of internal speed limits.				T
	11	STA	<p>Acceleration time constant: Used to set the acceleration time required to reach the rated speed from zero speed in response to the analog speed command and internal speed commands 1 to 3.</p> <p>If the preset command speed is lower than the rated speed, acceleration/deceleration time will be shorter.</p> <p>Example Set 3000 (3s) to accelerate the HC-MF series servo motor (rated speed: 3000r/min) from 0r/min to 1000 r/min in 1 second.</p>	0	ms	0 to 20000	S • T
12	STB	<p>Deceleration time constant: Used to set the deceleration time required to reach zero speed from the rated speed in response to the analog speed command and internal speed commands 1 to 3.</p>	0				
	13	STC	<p>S-pattern acceleration/deceleration time constant: Used to smooth start/stop of the servo motor.</p> <p>STA: Acceleration time constant (parameter No. 11) STB: Deceleration time constant (parameter No. 12) STC: S-pattern acceleration/deceleration time constant (parameter No. 13)</p>	0	ms	0 to 1000	S • T

## 2. OPERATION

Class	No.	Symbol	Name and Function	Initial Value	Unit	Setting Range	Control Mode
Basic parameters	14	TQC	<p>Torque command time constant: Used to set the constant of a low pass filter in response to the torque command.</p>  <p>TQC: Torque command time constant</p>	0	ms	0 to 20000	T
	15		<p>For manufacturer setting Must not be change.</p>	0			
	16	*BPS	<p>Communication baudrate selection, alarm history clear: Used to select the communication baudrate for use of the set-up software and to clear the alarm history.</p>  <p>Selection of baudrate for RS-232C 0: 9600 [bps] 1: 19200 [bps]</p> <p>Alarm history clear 0: Invalid 1: Valid When alarm history clear is made valid, the alarm history is cleared at next power-on. After the alarm history is cleared, the setting is automatically made invalid (reset to 0).</p>	0000		0000h to 0011h	P • S • T

## 2. OPERATION

Class	No.	Symbol	Name and Function	Initial Value	Unit	Setting Range	Control Mode
Basic parameters	17	MOD	Analog monitor output: Used to set the signal output for analog monitor.	0100		0000h to 0A0Ah	P • S • T
			 <p>             Analog monitor CH1 output selection              The set values and their definitions are as in analog monitor CH2.           </p> <p>             Analog monitor CH2 output selection              0: Servo motor speed (±8V/max. speed)              1: Torque (±8V/max. torque)              2: Servo motor speed (+8V/max. speed)              3: Torque (+8V/max. torque)              4: Current command output (±8V/max. current command)              5: Command pulse frequency (±8/400kpps)              6: Droop pulses 1/1 (±10V/128 pulses)              7: Droop pulses 1/16 (±10V/2048 pulses)              8: Droop pulses 1/64 (±10V/8192 pulses)              9: Droop pulses 1/256 (±10V/32768 pulses)              10: Droop pulses 1/1024 (±10V/131072 pulses)           </p>				

## 2. OPERATION

Class	No.	Symbol	Name and Function	Initial Value	Unit	Setting Range	Control Mode											
Basic parameters	18	*DMD	Status display selection: Used to select the status display shown at power-on.	0000		0000h to 001Ch	P • S • T											
			<div style="display: flex; align-items: center; margin-bottom: 10px;"> <table border="1" style="border-collapse: collapse; text-align: center;"> <tr> <td style="width: 20px; height: 20px;">0</td> <td style="width: 20px; height: 20px;">0</td> <td style="width: 20px; height: 20px;"></td> <td style="width: 20px; height: 20px;"></td> </tr> </table> <div style="margin-left: 10px;"> <p>Selection of status display at power-on</p> <ul style="list-style-type: none"> <li>0: Cumulative feedback pulses</li> <li>1: Servo motor speed</li> <li>2: Droop pulses</li> <li>3: Cumulative command pulses</li> <li>4: Command pulse frequency</li> <li>5: Analog speed command voltage (Note 1)</li> <li>6: Analog torque command voltage (Note 2)</li> <li>7: Regenerative load ratio</li> <li>8: Effective load ratio</li> <li>9: Peak load ratio</li> <li>A: Within one-revolution position</li> <li>B: ABS counter</li> <li>C: Load inertia moment ratio</li> </ul> </div> </div> <p>Note: 1. In speed control mode. Analog speed limit voltage in torque control mode.</p> <p>2. In torque control mode. Analog torque limit voltage in speed or position control mode.</p> <p>Status display at power-on in corresponding control mode 0: Depends on the control mode.</p> <table border="1" style="width: 100%; border-collapse: collapse; text-align: center;"> <thead> <tr> <th>Control Mode</th> <th>Status Display at Power-On</th> </tr> </thead> <tbody> <tr> <td>Position</td> <td>Cumulative feedback pulses</td> </tr> <tr> <td>Position/speed</td> <td>Cumulative feedback pulses/servo motor speed</td> </tr> <tr> <td>Speed</td> <td>Servo motor speed</td> </tr> <tr> <td>Speed/torque</td> <td>Servo motor speed/analog torque command voltage</td> </tr> <tr> <td>Torque</td> <td>Analog torque command voltage</td> </tr> <tr> <td>Torque/position</td> <td>Analog torque command voltage/cumulative feedback pulses</td> </tr> </tbody> </table> <p>1: Depends on the first digit setting of this parameter.</p>					0	0			Control Mode	Status Display at Power-On	Position	Cumulative feedback pulses	Position/speed	Cumulative feedback pulses/servo motor speed	Speed
0	0																	
Control Mode	Status Display at Power-On																	
Position	Cumulative feedback pulses																	
Position/speed	Cumulative feedback pulses/servo motor speed																	
Speed	Servo motor speed																	
Speed/torque	Servo motor speed/analog torque command voltage																	
Torque	Analog torque command voltage																	
Torque/position	Analog torque command voltage/cumulative feedback pulses																	


## 2. OPERATION

Class	No.	Symbol	Name and Function	Initial Value	Unit	Setting Range	Control Mode								
Basic parameters	19	*BLK	Parameter block: Used to select the reference and write ranges of the parameters.	0000		0000h to 000Ch	P • S • T								
			<table border="1"> <thead> <tr> <th>Set Value</th> <th>Reference Range</th> <th>Write Range</th> </tr> </thead> <tbody> <tr> <td>0000</td> <td>No.0 to 19</td> <td>No.0 to 19</td> </tr> <tr> <td>000A</td> <td>No.19</td> <td>No.19</td> </tr> <tr> <td>000B</td> <td>No.0 to 49</td> <td>No.0 to 19</td> </tr> <tr> <td>000C</td> <td>No.0 to 49</td> <td>No.0 to 49</td> </tr> </tbody> </table>					Set Value	Reference Range	Write Range	0000	No.0 to 19	No.0 to 19	000A	No.19
Set Value	Reference Range	Write Range													
0000	No.0 to 19	No.0 to 19													
000A	No.19	No.19													
000B	No.0 to 49	No.0 to 19													
000C	No.0 to 49	No.0 to 49													
Expansion parameters	20	*OP2	Function selection 2: Used to select restart after instantaneous power failure, servo lock at a stop in speed control mode, and slight vibration suppression control.	0000		0000h to 0111h									
			<table border="1"> <tr> <td>0</td> <td></td> <td></td> <td></td> </tr> </table> <p>Restart after instantaneous power failure If the input power supply voltage had reduced in the speed control mode to stop the servo motor due to the undervoltage alarm (A. 10) but the supply voltage has returned to normal, the servo motor can be restarted by merely switching on the start signal without resetting the alarm. 0: Invalid 1: Valid</p> <p>Stop-time servo lock selection The shaft can be servo-locked to remain still at a stop in the speed control mode. 0: Valid 1: Invalid</p> <p>Slight vibration suppression control Used to suppress vibration at a stop. 0: Invalid 1: Valid</p>				0				S				
0															
							P								

## 2. OPERATION

Class	No.	Symbol	Name and Function	Initial Value	Unit	Setting Range	Control Mode																												
Expansion parameters	21	*OP3	Function selection 3 (Command pulse selection): Used to select the input form of the pulse train input signal. (Refer to Section 3-3 (1) 4.) <div style="display: flex; align-items: center; margin-top: 10px;"> <table border="1" style="border-collapse: collapse; text-align: center;"> <tr> <td style="width: 20px; height: 20px;">0</td> <td style="width: 20px; height: 20px;">0</td> <td style="width: 20px; height: 20px;"></td> <td style="width: 20px; height: 20px;"></td> </tr> </table> <div style="margin-left: 10px;"> <p>Command pulse train input form                0: Forward/reverse rotation pulse train                1: Signed pulse train                2: A/B phase pulse train</p> <p>Pulse train logic selection                0: Positive logic                1: Negative logic</p> </div> </div>	0	0			0000		0000h to 0012h	P																								
			0	0																															
<table border="1" style="width: 100%; border-collapse: collapse; text-align: center;"> <thead> <tr> <th rowspan="2"></th> <th rowspan="2">Command Pulse Train Form</th> <th colspan="2">Input Waveform</th> </tr> <tr> <th>Forward rotation</th> <th>Reverse rotation</th> </tr> </thead> <tbody> <tr> <td rowspan="4" style="writing-mode: vertical-rl; transform: rotate(180deg);">Negative logic</td> <td>Forward rotation pulse train</td> <td></td> <td></td> </tr> <tr> <td>Reverse rotation pulse train (Set value 0010)</td> <td></td> <td></td> </tr> <tr> <td>Pulse train positive sign (Set value 0011)</td> <td></td> <td></td> </tr> <tr> <td>A-phase pulse train</td> <td></td> <td></td> </tr> <tr> <td rowspan="4" style="writing-mode: vertical-rl; transform: rotate(180deg);">Positive logic</td> <td>Forward rotation pulse train</td> <td></td> <td></td> </tr> <tr> <td>Reverse rotation pulse train (Set value 0000)</td> <td></td> <td></td> </tr> <tr> <td>Pulse train positive sign (Set value 0001)</td> <td></td> <td></td> </tr> <tr> <td>A-phase pulse train</td> <td></td> <td></td> </tr> </tbody> </table>		Command Pulse Train Form	Input Waveform		Forward rotation	Reverse rotation	Negative logic	Forward rotation pulse train			Reverse rotation pulse train (Set value 0010)			Pulse train positive sign (Set value 0011)			A-phase pulse train			Positive logic	Forward rotation pulse train			Reverse rotation pulse train (Set value 0000)			Pulse train positive sign (Set value 0001)			A-phase pulse train					
			Command Pulse Train Form	Input Waveform																															
	Forward rotation	Reverse rotation																																	
Negative logic	Forward rotation pulse train																																		
	Reverse rotation pulse train (Set value 0010)																																		
	Pulse train positive sign (Set value 0011)																																		
	A-phase pulse train																																		
Positive logic	Forward rotation pulse train																																		
	Reverse rotation pulse train (Set value 0000)																																		
	Pulse train positive sign (Set value 0001)																																		
	A-phase pulse train																																		

## 2. OPERATION

Class	No.	Symbol	Name and Function	Initial Value	Unit	Setting Range	Control Mode																												
Expansion parameters	22	*OP4	<p>Function selection 4:</p>  <p>Selection of servo motor stop pattern at LSP/LSN signal off            0: Sudden stop            1: Slow stop</p> <ul style="list-style-type: none"> <li>In the position control mode, the servo motor is decelerated to a stop according to parameter No. 7 setting.</li> <li>In the speed control mode, the servo motor is decelerated to a stop according to parameter No. 12 setting.</li> </ul> <p>VC/VLA/TC/TLA voltage averaging            Used to set the filtering time when the analog speed command (VC) voltage or analog speed limit (VLA), Analog command (TC) or analog torque limit (TLA) is imported. Set 0 to vary the speed to voltage fluctuation in real time. Increase the set value to vary the speed slower to voltage fluctuation.</p> <table border="1" data-bbox="552 965 928 1169"> <thead> <tr> <th>Set Value</th> <th>Filtering Time [ms]</th> </tr> </thead> <tbody> <tr> <td>0</td> <td>0</td> </tr> <tr> <td>1</td> <td>1.77</td> </tr> <tr> <td>2</td> <td>3.55</td> </tr> <tr> <td>3</td> <td>7.11</td> </tr> </tbody> </table> <p>Machine resonance suppression filter            Used to set the frequency that matches the resonance frequency of the mechanical system. (Refer to Section 2-4-2.)</p> <table border="1" data-bbox="517 1323 895 1688"> <thead> <tr> <th>Set value</th> <th>Notch Frequency [Hz]</th> </tr> </thead> <tbody> <tr> <td>0</td> <td>Not used</td> </tr> <tr> <td>1</td> <td>1125</td> </tr> <tr> <td>2</td> <td>563</td> </tr> <tr> <td>3</td> <td>375</td> </tr> <tr> <td>4</td> <td>282</td> </tr> <tr> <td>5</td> <td>225</td> </tr> <tr> <td>6</td> <td>188</td> </tr> <tr> <td>7</td> <td>161</td> </tr> </tbody> </table>	Set Value	Filtering Time [ms]	0	0	1	1.77	2	3.55	3	7.11	Set value	Notch Frequency [Hz]	0	Not used	1	1125	2	563	3	375	4	282	5	225	6	188	7	161	0000		0000h to 7301h	P • S • T
Set Value	Filtering Time [ms]																																		
0	0																																		
1	1.77																																		
2	3.55																																		
3	7.11																																		
Set value	Notch Frequency [Hz]																																		
0	Not used																																		
1	1125																																		
2	563																																		
3	375																																		
4	282																																		
5	225																																		
6	188																																		
7	161																																		



## 2. OPERATION

Class	No.	Symbol	Name and Function	Initial Value	Unit	Setting Range	Control Mode												
Expansion parameters	23	FFC	Feed forward gain: Used to set the feed forward gain in position control. By setting 100% for constant-speed operation, droop pulses will not be generated. Note that sudden acceleration/deceleration will increase overshoot. (As a guideline, acceleration/deceleration time to/from rated speed is 1s or longer when the set value is 100.)  <div style="border: 1px solid black; padding: 5px; width: fit-content;"> <p><b>MEMORANDUM</b> When setting this parameter, always set auto tuning to "No" (parameter No. 2).</p> </div>	0	%	0 to 100	P												
	24	ZSP	Zero speed: Used to set the output range of the zero speed signal (ZSP).	50	r/min	0 to 10000	P • S • T												
	25	VCM	Analog speed command maximum speed: Used to set the speed at the maximum input voltage (10V) of the analog speed command (VC). When it is set to 0, the speed comes to the rated speed of the servo motor connected.	0	r/min	0	S												
			Analog speed limit maximum speed: Used to set the speed at the maximum input voltage (10V) of the analog speed limit (VLA). When it is set to 0, the speed comes to the rated speed of the servo motor connected.	0		0													
	26	TLC	Analog torque command maximum output: Used to set the output torque at the analog torque command voltage (TC=±8V) of +8V on the assumption that the maximum torque is 100[%]. For example, set 50 to output (maximum torque x 50/100) at the TC of +8V.	100	%	0 to 1000	T												
			Encoder output pulses: Used to set the number of output pulses per encoder revolution output by the servo amplifier.					4000	pulse	5 to 16384	P • S • T								
	28	TL1	Internal torque limit 1: Set this parameter to limit servo motor-generated torque on the assumption that the maximum torque is 100[%]. When 0 is set, torque is not produced. When analog monitor output is used to output torque, this set value is the maximum output voltage (+8V).	100	%	0 to 100	T												
Internal torque limit 1: Set this parameter to limit servo motor-generated torque on the assumption that the maximum torque is 100[%]. When 0 is set, torque is not produced.  <table border="1" style="width: 100%; border-collapse: collapse;"> <thead> <tr> <th colspan="2">Across TL-SG</th> <th colspan="2">Torque Limit</th> </tr> </thead> <tbody> <tr> <td>Open</td> <td colspan="3">Internal torque limit 1 (Parameter No. 28)</td> </tr> <tr> <td rowspan="3">Short</td> <td colspan="2">Torque limit relationship</td> <td>Valid torque limit</td> </tr> <tr> <td colspan="2">Analog torque limit &lt; internal torque limit 1</td> <td>Analog torque limit</td> </tr> <tr> <td colspan="2">Analog torque limit &gt; internal torque limit 1</td> <td>Internal torque limit 1</td> </tr> </tbody> </table> When analog monitor output is used to output torque, this set value is the maximum output voltage (+8V).			Across TL-SG					Torque Limit		Open	Internal torque limit 1 (Parameter No. 28)			Short	Torque limit relationship		Valid torque limit	Analog torque limit < internal torque limit 1	
Across TL-SG		Torque Limit																	
Open	Internal torque limit 1 (Parameter No. 28)																		
Short	Torque limit relationship		Valid torque limit																
	Analog torque limit < internal torque limit 1		Analog torque limit																
	Analog torque limit > internal torque limit 1		Internal torque limit 1																

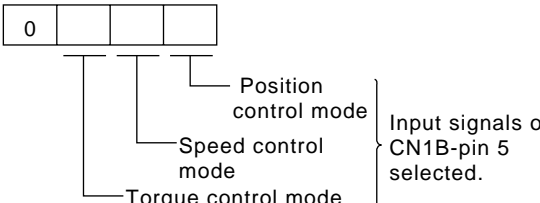
## 2. OPERATION

Class	No.	Symbol	Name and Function	Initial Value	Unit	Setting Range	Control Mode
Expansion parameters	29	VCO	Analog speed command offset: Used to set the offset voltage of the analog speed command (VC). When automatic VC offset is used, the automatically offset value is set to this parameter. (See section 2-3-3.) The initial value is the value provided by the automatic VC offset function before shipment at the VC-LG voltage of 0V.	Depends on servo amplifier.	mV	—999 to 999	S
			Analog speed limit offset: Used to set the offset voltage of the analog speed limit (VLA). When automatic VC offset is used, the automatically offset value is set to this parameter. (See section 2-3-3.) The initial value is the value provided by the automatic VC offset function before shipment at the VLA-LG voltage of 0V.				T
	30	TLO	Analog torque command offset: Used to set the offset voltage of the analog torque command (TC).	0	mV	—999 to 999	T
			Analog torque limit offset: Used to set the offset voltage of the analog torque limit (TLA).				S
	31	MO1	Analog monitor 1 offset: Used to set the offset voltage of the analog monitor 1 output (MO1).	0	mV	—999 to 999	P • S • T
	32	MO2	Analog monitor 2 offset: Used to set the offset voltage of the analog monitor 2 output (MO2).	0	mV	—999 to 999	
	33	MBR	Electromagnetic brake sequence output: Used to set the delay time between when the electromagnetic brake interlock signal (MBR) switches off and when the base circuit is shut off.	100	ms	0 to 1000	P • S • T
	34	GD2	Ratio of load inertia moment to servo motor inertia moment: Used to set the ratio of the load inertia moment to the servo motor inertia moment. Note that when auto tuning is selected, the result of auto tuning is automatically set.	70	0.1 times	0 to 1000	P • S
	35	PG2	Position loop gain 2: Used to set the gain of the position loop. Set this parameter to increase position response to load disturbance. Higher setting increases the response level but is liable to generate vibration and/or noise.	30	rad/s	1 to 500	P
	36	VG1	Speed loop gain 1: Normally this parameter setting need not be changed. Higher setting increases the response level but is liable to generate vibration and/or noise.	216	rad/s	20 to 5000	P • S
	37	VG2	Speed loop gain 2: Set this parameter when vibration occurs on machines of low rigidity or large backlash. Higher setting increases the response level but is liable to generate vibration and/or noise.	714	rad/s	20 to 8000	P • S

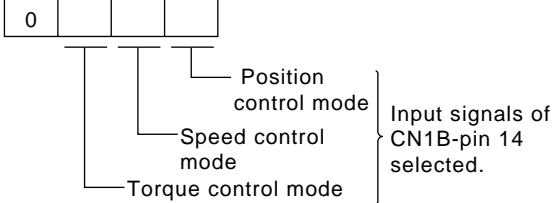
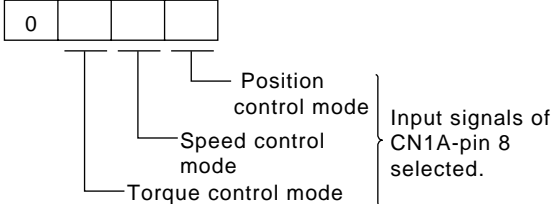
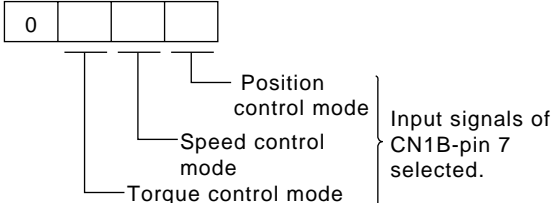
## 2. OPERATION

Class	No.	Symbol	Name and Function	Initial Value	Unit	Setting Range	Control Mode																	
Expansion parameters	38	VIC	Speed integral compensation Used to set the constant of integral compensation.	20	ms	1 to 1000	P • S																	
	39	VDC	Speed differential compensation: Used to set the differential compensation value.	980		0 to 1000	P • S																	
	40		For manufacturer setting Must not be change																					
	41	*DIA	Input signal automatic ON selection: Used to set automatic ON of SON, LSP and LSN.  <div style="display: flex; align-items: flex-start;"> <table border="1" style="margin-right: 10px;"> <tr> <td style="width: 20px; text-align: center;">0</td> <td style="width: 20px;"></td> <td style="width: 20px;"></td> <td style="width: 20px;"></td> </tr> </table> <div style="margin-left: 10px;"> <p>Servo on signal (SON) input selection 0: Switched on/off by external input. 1: Switched on automatically in servo amplifier. (No need of external wiring)</p> <p>Forward rotation stroke end signal (LSP) input selection 0: Switched on/off by external input. 1: Switched on automatically in servo amplifier. (No need of external wiring)</p> <p>Reverse rotation stroke end signal (LSN) input selection 0: Switched on/off by external input. 1: Switched on automatically in servo amplifier. (No need of external wiring)</p> </div> </div>	0				0000		0000h to 0111h	P • S • T   P • S													
0																								
42	*DI1	Input signal selection 1: Used to assign the control mode changing signal input pins and to set the clear signal.  <div style="display: flex; align-items: flex-start;"> <table border="1" style="margin-right: 10px;"> <tr> <td style="width: 20px; text-align: center;">0</td> <td style="width: 20px; text-align: center;">0</td> <td style="width: 20px;"></td> <td style="width: 20px;"></td> </tr> </table> <div style="margin-left: 10px;"> <p>Control change signal (LOP) input pin assignment Used to set the control mode change signal input connector pins. Note that this parameter is made valid when parameter No. 0 is set to select the position/speed, speed/torque or torque/position change mode.</p> <table border="1" style="width: 100%; margin: 10px 0;"> <thead> <tr> <th style="width: 100px;">Set Value</th> <th>Connector Pin No.</th> </tr> </thead> <tbody> <tr><td>0</td><td>CN1B – 5</td></tr> <tr><td>1</td><td>CN1B – 14</td></tr> <tr><td>2</td><td>CN1A – 8</td></tr> <tr><td>3</td><td>CN1B – 7</td></tr> <tr><td>4</td><td>CN1B – 8</td></tr> <tr><td>5</td><td>CN1B – 9</td></tr> </tbody> </table> <p>Clear signal (CR) selection 0: Droop pulses are cleared on the leading edge. 1: Always cleared while on.</p> </div> </div>	0	0			Set Value	Connector Pin No.	0	CN1B – 5	1	CN1B – 14	2	CN1A – 8	3	CN1B – 7	4	CN1B – 8	5	CN1B – 9	0003		0000h to 0015h	P/S S/T T/P   P • S • T
0	0																							
Set Value	Connector Pin No.																							
0	CN1B – 5																							
1	CN1B – 14																							
2	CN1A – 8																							
3	CN1B – 7																							
4	CN1B – 8																							
5	CN1B – 9																							

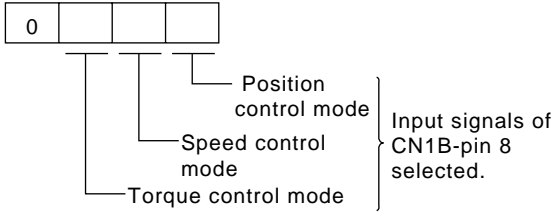
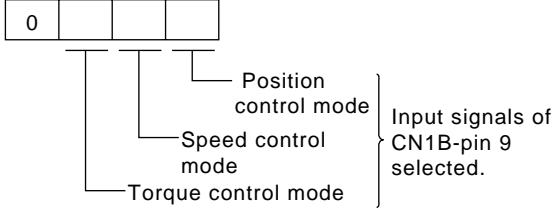
## 2. OPERATION

Class	No.	Symbol	Name and Function	Initial Value	Unit	Setting Range	Control Mode																																															
Expansion parameters	43	*DI2	<p>Input signal selection 2 (CN1B-pin 5):</p> <div style="border: 1px solid black; padding: 5px; margin-bottom: 10px;"> <p><b>MEMORANDUM</b> This parameter is unavailable when parameter No. 42 is set to assign the control change signal (LOP) to CN 1B-pin 5.</p> </div> <p>Allows any input signal to be assigned to CN1B-pin 5. Note that the setting digit and assigned signal differ according to the control mode.</p> <div style="margin-bottom: 10px;">  </div> <p>Signals that may be assigned in each control mode are indicated below by their symbols. Diagonally shaded area indicates invalid setting.</p> <table border="1" style="margin-bottom: 10px;"> <thead> <tr> <th rowspan="2">Set Value</th> <th colspan="3">(Note) Control Mode</th> </tr> <tr> <th>P</th> <th>S</th> <th>T</th> </tr> </thead> <tbody> <tr> <td>0</td> <td style="background: linear-gradient(to top right, transparent 49%, black 49%, black 51%, transparent 51%);"></td> <td style="background: linear-gradient(to top right, transparent 49%, black 49%, black 51%, transparent 51%);"></td> <td style="background: linear-gradient(to top right, transparent 49%, black 49%, black 51%, transparent 51%);"></td> </tr> <tr> <td>1</td> <td>SON</td> <td>SON</td> <td>SON</td> </tr> <tr> <td>2</td> <td>RES</td> <td>RES</td> <td>RES</td> </tr> <tr> <td>3</td> <td>PC</td> <td>PC</td> <td style="background: linear-gradient(to top right, transparent 49%, black 49%, black 51%, transparent 51%);"></td> </tr> <tr> <td>4</td> <td>TL</td> <td>TL</td> <td>TL</td> </tr> <tr> <td>5</td> <td>CR</td> <td>CR</td> <td>CR</td> </tr> <tr> <td>6</td> <td style="background: linear-gradient(to top right, transparent 49%, black 49%, black 51%, transparent 51%);"></td> <td>SP1</td> <td>SP1</td> </tr> <tr> <td>7</td> <td style="background: linear-gradient(to top right, transparent 49%, black 49%, black 51%, transparent 51%);"></td> <td>SP2</td> <td>SP2</td> </tr> <tr> <td>8</td> <td style="background: linear-gradient(to top right, transparent 49%, black 49%, black 51%, transparent 51%);"></td> <td>ST1</td> <td>RS2</td> </tr> <tr> <td>9</td> <td style="background: linear-gradient(to top right, transparent 49%, black 49%, black 51%, transparent 51%);"></td> <td>ST2</td> <td>RS1</td> </tr> </tbody> </table> <p>Note: P: Position control mode S: Speed control mode T: Torque control mode</p>	Set Value	(Note) Control Mode			P	S	T	0				1	SON	SON	SON	2	RES	RES	RES	3	PC	PC		4	TL	TL	TL	5	CR	CR	CR	6		SP1	SP1	7		SP2	SP2	8		ST1	RS2	9		ST2	RS1	0111		0000h to 0999h	P • S • T
Set Value	(Note) Control Mode																																																					
	P	S	T																																																			
0																																																						
1	SON	SON	SON																																																			
2	RES	RES	RES																																																			
3	PC	PC																																																				
4	TL	TL	TL																																																			
5	CR	CR	CR																																																			
6		SP1	SP1																																																			
7		SP2	SP2																																																			
8		ST1	RS2																																																			
9		ST2	RS1																																																			

## 2. OPERATION

Class	No.	Symbol	Name and Function	Initial Value	Unit	Setting Range	Control Mode
Expansion parameters	44	*DI3	<p>Input signal selection 3 (CN1B-pin 14):</p> <p>Allows any input signal to be assigned to CN1B-pin 14. The assignable signals and setting method are the same as in input signal selection 2 (parameter No. 43).</p>  <p><b>MEMORANDUM</b> This parameter is unavailable when parameter No. 42 is set to assign the control change signal (LOP) to CN1B-pin 14.</p>	0222		0000h to 0999h	P • S • T
	45	*DI4	<p>Input signal selection 4 (CN1A-pin 8):</p> <p>Allows any input signal to be assigned to CN1A-pin 8. The assignable signals and setting method are the same as in input signal selection 2 (parameter No. 43).</p>  <p><b>MEMORANDUM</b> This parameter is unavailable when parameter No. 42 is set to assign the control change signal (LOP) to CN1 A-pin 8.</p>	0665		0000h to 0999h	P • S • T
	46	*DI5	<p>Input signal selection 5 (CN1B-pin 7):</p> <p>Allows any input signal to be assigned to CN1B-pin 7. The assignable signals and setting method are the same as in input signal selection 2 (parameter No. 43).</p>  <p><b>MEMORANDUM</b> This parameter is unavailable when parameter No. 42 is set to assign the control change signal (LOP) to CN1 B-pin 7.</p>	0770		0000h to 0999h	P • S • T

## 2. OPERATION

Class	No.	Symbol	Name and Function	Initial Value	Unit	Setting Range	Control Mode
Expansion parameters	47	*DI6	<p>Input signal selection 6 (CN1B-pin 8):</p> <p>Allows any input signal to be assigned to CN1B-pin 8. The assignable signals and setting method are the same as in input signal selection 2 (parameter No. 43).</p>  <p><b>MEMORANDUM</b> This parameter is unavailable when parameter No. 42 is set to assign the control change signal (LOP) to CN1B-pin 8.</p> <p>When "Use in absolute position detection system" is selected with parameter No. 1, the CN1B-8 pin comes into the ABS transfer mode (ABSM).</p>	0883		0000h to 0999h	P • S • T
	48	*DI7	<p>Input signal selection 7 (CN1B-pin 9):</p> <p>Allows any input signal to be assigned to CN1B-pin 9. The assignable signals and setting method are the same as in input signal selection 2 (parameter No. 43).</p>  <p><b>MEMORANDUM</b> This parameter is unavailable when parameter No. 42 is set to assign the control change signal (LOP) to CN1B-pin 9.</p> <p>When "Use in absolute position detection system" is selected with parameter No. 1, the CN1B-9 pin comes into the ABS transfer mode (ABSM).</p>	0994		0000h to 0999h	P • S • T

## 2. OPERATION

Class	No.	Symbol	Name and Function	Initial Value	Unit	Setting Range	Control Mode																																																																																																							
Expansion parameters	49	*DO1	<p>Output signal selection 1: Used to select the connector pins to output the alarm code, warning (WNG) and battery warning (BWNG).</p> <div style="border: 1px solid black; width: 40px; height: 20px; display: flex; align-items: center; justify-content: center; margin-bottom: 5px;">0</div> <p>Setting of alarm code output</p> <table border="1" style="margin-left: 20px;"> <thead> <tr> <th colspan="4">Connector Pins</th> </tr> <tr> <th>Set Value</th> <th>CN1B-19</th> <th>CN1A-18</th> <th>CN1A-19</th> </tr> </thead> <tbody> <tr> <td>0</td> <td>ZSP</td> <td>INP or SA</td> <td>RD</td> </tr> <tr> <td>1</td> <td colspan="3">Alarm code is output at alarm occurrence.</td> </tr> </tbody> </table> <table border="1" style="margin-left: 20px; margin-top: 5px;"> <thead> <tr> <th colspan="3">(Note) Alarm Code</th> <th rowspan="2">Alarm Display</th> <th rowspan="2">Name</th> </tr> <tr> <th>CN1B pin 19</th> <th>CN1A pin 18</th> <th>CN1A pin 19</th> </tr> </thead> <tbody> <tr> <td rowspan="8">0</td> <td rowspan="8">0</td> <td rowspan="8">0</td> <td>8888</td> <td>Watchdog</td> </tr> <tr> <td>A. 11</td> <td>Board error 1</td> </tr> <tr> <td>A. 12</td> <td>Memory error 1</td> </tr> <tr> <td>A. 13</td> <td>Clock error</td> </tr> <tr> <td>A. 15</td> <td>Memory error 2</td> </tr> <tr> <td>A. 17</td> <td>Board error 2</td> </tr> <tr> <td>A. 18</td> <td>Board error 3</td> </tr> <tr> <td>A. 37</td> <td>Parameter error</td> </tr> <tr> <td rowspan="2">0</td> <td rowspan="2">0</td> <td>1</td> <td>A. 30</td> <td>Regenerative fault</td> </tr> <tr> <td>A. 33</td> <td>Overvoltage</td> </tr> <tr> <td>0</td> <td>1</td> <td>0</td> <td>A. 10</td> <td>Undervoltage</td> </tr> <tr> <td rowspan="3">0</td> <td rowspan="3">1</td> <td rowspan="3">1</td> <td>A. 46</td> <td>Motor overheat</td> </tr> <tr> <td>A. 50</td> <td>Overload 1</td> </tr> <tr> <td>A. 51</td> <td>Overload 2</td> </tr> <tr> <td rowspan="2">1</td> <td rowspan="2">0</td> <td rowspan="2">0</td> <td>A. 24</td> <td>Ground fault</td> </tr> <tr> <td>A. 32</td> <td>Overcurrent</td> </tr> <tr> <td rowspan="3">1</td> <td rowspan="3">0</td> <td rowspan="3">1</td> <td>A. 31</td> <td>Overspeed</td> </tr> <tr> <td>A. 35</td> <td>Command pulse fault</td> </tr> <tr> <td>A. 52</td> <td>Error excessive</td> </tr> <tr> <td rowspan="3">1</td> <td rowspan="3">1</td> <td rowspan="3">0</td> <td>A. 16</td> <td>Encoder error 1</td> </tr> <tr> <td>A. 20</td> <td>Encoder error 2</td> </tr> <tr> <td>A. 25</td> <td>Absolute position erasure</td> </tr> </tbody> </table> <p>Note: 0:OFF 1:ON</p> <p>Setting of warning (WNG) output Select the connector pin to output warning. The old signal before selection will be unavailable.</p> <table border="1" style="margin-left: 20px;"> <thead> <tr> <th>Set Value</th> <th>Connector Pin No.</th> </tr> </thead> <tbody> <tr> <td>0</td> <td>Not output.</td> </tr> <tr> <td>1</td> <td>CN1A-19</td> </tr> <tr> <td>2</td> <td>CN1B-18</td> </tr> <tr> <td>3</td> <td>CN1A-18</td> </tr> <tr> <td>4</td> <td>CN1B-19</td> </tr> <tr> <td>5</td> <td>CN1B-6</td> </tr> </tbody> </table> <p>Setting of battery warning (BWNG) output Select the connector pin to output battery warning. The old signal before selection will be unavailable. Set this function as in the second digit of this parameter.</p>	Connector Pins				Set Value	CN1B-19	CN1A-18	CN1A-19	0	ZSP	INP or SA	RD	1	Alarm code is output at alarm occurrence.			(Note) Alarm Code			Alarm Display	Name	CN1B pin 19	CN1A pin 18	CN1A pin 19	0	0	0	8888	Watchdog	A. 11	Board error 1	A. 12	Memory error 1	A. 13	Clock error	A. 15	Memory error 2	A. 17	Board error 2	A. 18	Board error 3	A. 37	Parameter error	0	0	1	A. 30	Regenerative fault	A. 33	Overvoltage	0	1	0	A. 10	Undervoltage	0	1	1	A. 46	Motor overheat	A. 50	Overload 1	A. 51	Overload 2	1	0	0	A. 24	Ground fault	A. 32	Overcurrent	1	0	1	A. 31	Overspeed	A. 35	Command pulse fault	A. 52	Error excessive	1	1	0	A. 16	Encoder error 1	A. 20	Encoder error 2	A. 25	Absolute position erasure	Set Value	Connector Pin No.	0	Not output.	1	CN1A-19	2	CN1B-18	3	CN1A-18	4	CN1B-19	5	CN1B-6	0000		0000h to 0551h	P • S • T
			Connector Pins																																																																																																											
Set Value	CN1B-19	CN1A-18	CN1A-19																																																																																																											
0	ZSP	INP or SA	RD																																																																																																											
1	Alarm code is output at alarm occurrence.																																																																																																													
(Note) Alarm Code			Alarm Display	Name																																																																																																										
CN1B pin 19	CN1A pin 18	CN1A pin 19																																																																																																												
0	0	0	8888	Watchdog																																																																																																										
			A. 11	Board error 1																																																																																																										
			A. 12	Memory error 1																																																																																																										
			A. 13	Clock error																																																																																																										
			A. 15	Memory error 2																																																																																																										
			A. 17	Board error 2																																																																																																										
			A. 18	Board error 3																																																																																																										
			A. 37	Parameter error																																																																																																										
0	0	1	A. 30	Regenerative fault																																																																																																										
		A. 33	Overvoltage																																																																																																											
0	1	0	A. 10	Undervoltage																																																																																																										
0	1	1	A. 46	Motor overheat																																																																																																										
			A. 50	Overload 1																																																																																																										
			A. 51	Overload 2																																																																																																										
1	0	0	A. 24	Ground fault																																																																																																										
			A. 32	Overcurrent																																																																																																										
1	0	1	A. 31	Overspeed																																																																																																										
			A. 35	Command pulse fault																																																																																																										
			A. 52	Error excessive																																																																																																										
1	1	0	A. 16	Encoder error 1																																																																																																										
			A. 20	Encoder error 2																																																																																																										
			A. 25	Absolute position erasure																																																																																																										
Set Value	Connector Pin No.																																																																																																													
0	Not output.																																																																																																													
1	CN1A-19																																																																																																													
2	CN1B-18																																																																																																													
3	CN1A-18																																																																																																													
4	CN1B-19																																																																																																													
5	CN1B-6																																																																																																													

## 2. OPERATION

### 2-4 Adjustments

#### 2-4-1 Auto tuning

In general machines, gains are automatically adjusted by auto tuning. As the corresponding parameter is factory-set to make auto tuning valid, merely running the servo motor will automatically set the optimum gains for the machine without special operation or setting.

However, if you are not satisfied with machine motions during operation, change and adjust the response level setting (parameter No. 2) of auto tuning in the following procedure.

Actual Machine Motion	Ideal Machine Motion	Parameter No. 2 Setting Method
Settling time is long (Note)	Shorter settling time	Increase the set value of the response level.
Overshoot occurs at a stop.	Less overshoot	Decrease the set value of the response level. Select "large friction" in machine selection.
Gear noise is generated from the machine.	Smaller gear noise	Decrease the set value of the response level.

Note: Settling time indicates a period of time from when the command pulse value is zeroed to when the servo motor comes to a stop.

#### 2-4-2 Manual gain adjustment

In most machines, gains can be adjusted automatically by auto tuning.

In the following cases, however, the gains should be adjusted manually.

Manual Gain Adjustment Is Required When	Phenomenon	Adjustment Procedure
1) The machine vibrates at a low-range resonance frequency.	The servo motor shaft vibrates at a high frequency (10Hz or more) a. When the machine generates large noise and vibrates, the motion of the servo motor shaft is invisible. b. When the response level setting is increased by auto tuning, vibration increases.	Adjustment 1 Adjustment 2
2) The servo motor vibrates on a machine whose ratio of load inertia moment to servo motor inertia moment is 20 or more times.	The servo motor shaft vibrates at a low frequency (5Hz or less). a. When vibration occurs, the lateral vibration of the servo motor shaft is visible. b. The ratio of load inertia moment to servo motor inertia moment is extremely large.	Adjustment 3
3) The settling time provided by auto tuning should be further decreased.		Adjustment 4
4) The position control gain of each axis should be set to the same for interpolation operation with two or more axes.		Adjustment 5



## 2. OPERATION

The following parameters are used for manual gain adjustment. Note that 000C should be set in parameter No. 19 (parameter write disable) to make the expansion parameters valid.

Parameter No.	Name
No. 2	Auto tuning
No.34	Ratio of load inertia moment to servo motor inertia moment
No.22	Function selection 4 (Machine resonance suppression filter)
No.6	Position loop gain 1
No.35	Position loop gain 2
No.36	Speed loop gain 1
No.37	Speed loop gain 2
No.38	Speed integral compensation

### Adjustment 1

Step	Operation	Description
1	Set 0101 in parameter No. 2.	Auto tuning is selected. Response is set to low level.
2	Set 1□□□ in parameter No. 22.	Machine resonance frequency: 1125Hz
3	Switch servo on and perform operation several times.	Auto tuning is performed. Check to see if vibration reduced.
4	Increase the setting of the fourth digit in parameter No. 22 sequentially and execute step 3.	The optimum value is achieved just before vibration begins to increase.
5	To reduce the settling time, increase the response level of parameter No. 2 sequentially and execute steps 2 to 4.	

## 2. OPERATION

### Adjustment 2

Step	Operation	Description
1	Set 0101 in parameter No. 2.	Auto tuning is selected. Response is set to low level.
2	Set the machine's load inertia moment to servo motor inertia moment in parameter No. 34. (When it is unclear, set an approximate value.)	When this parameter value is set, the following parameter values are set automatically. Each value provides an ideal, hunting-less gain for parameter No. 34 if machine resonance does not occur. <ul style="list-style-type: none"> <li>• Parameter No. 6</li> <li>• Parameter No. 35</li> <li>• Parameter No. 36</li> <li>• Parameter No. 37</li> <li>• Parameter No. 38</li> </ul>
3	Set □2□□ in parameter No. 2.	Auto tuning is made invalid to enable manual setting of parameters No. 6 • 35 to 38.
4	In parameter No. 37, set a value about 100 smaller than the value set automatically in step 3.	The optimum value is achieved just before vibration begins to increase.
5	Execute steps 2 to 4 of Adjustment 1.	
6	When machine response does not occur any more, confirm the operating status, and at the same time, gradually increase the setting of parameter No. 37 reduced in step 4.	Set a value which is about 50 to 100 smaller than the set value at which gear noise and/or vibration begins to be generated by machine resonance.
7	To reduce the settling time, increase the response level of parameter No. 2 sequentially and execute steps 1 to 6.	

### Adjustment 3

Step	Operation	Description
1	Set 0101 in parameter No. 2.	Auto tuning is selected. Response is set to low level.
2	Set the machine's load inertia moment to servo motor inertia moment in parameter No. 34. (When it is unclear, set an approximate value.)	When this parameter value is set, the following parameter values are set automatically. Each value provides an ideal, hunting-less gain for parameter No. 34 if machine resonance does not occur. <ul style="list-style-type: none"> <li>• Parameter No. 6</li> <li>• Parameter No. 35</li> <li>• Parameter No. 36</li> <li>• Parameter No. 37</li> <li>• Parameter No. 38</li> </ul>
3	Switch servo on and perform operation several	Auto tuning is performed.
4	If vibration still persists, execute steps 2 and 3.	
5	If vibration occurs due to machine resonance, make adjustment in the procedure of Adjustment 1 or 2.	

## 2. OPERATION

### Adjustment 4

Step	Operation	Description
1	Set 0101 in parameter No. 2.	Auto tuning is selected. Response is set to low level.
2	Switch servo on and perform operation several times.	Auto tuning is performed. Check to see if vibration reduced.
3	Make gain adjustment in either of the following methods 1) and 2).	Temporary adjustment
	1) Set the machine's load inertia moment to servo motor inertia moment in parameter No. 34. (When it is unclear, set an approximate value.)	When this parameter value is set, the following parameter values are set automatically. Each value provides an ideal, hunting-less gain for parameter No. 34 if machine resonance does not occur. <ul style="list-style-type: none"> <li>• Parameter No. 6</li> <li>• Parameter No. 35</li> <li>• Parameter No. 36</li> <li>• Parameter No. 37</li> <li>• Parameter No. 38</li> </ul>
	2) Switch servo on and perform operation	Auto tuning is performed.
4	Set <input type="checkbox"/> 2 <input type="checkbox"/> <input type="checkbox"/> in parameter No. 2.	Auto tuning is made invalid to enable manual setting of parameters No. 6 • 35 to 38.
5	While confirming the operating status, adjust the following parameters: <ul style="list-style-type: none"> <li>• Parameter No. 6</li> <li>• Parameter No. 35</li> <li>• Parameter No. 36</li> <li>• Parameter No. 37</li> <li>• Parameter No. 38</li> </ul>	The optimum value is achieved just before vibration begins to increase.
		Increase the setting to reduce the settling time. Note that overshoot is more liable to occur.
		Increase the setting to improve servo response. Note that vibration is more liable to occur.
		Decrease the setting to keep the speed constant to load disturbance and increase holding force at a stop (servo rigidity). Note that overshoot

### Adjustment 5

Step	Operation	Description
1	Adjust the gains of all axes in any of Adjustment 1 to 4 procedures. The gains of each axis are adjusted.	The gains of each axis are adjusted.
2	Set <input type="checkbox"/> 0 <input type="checkbox"/> <input type="checkbox"/> or <input type="checkbox"/> 2 <input type="checkbox"/> <input type="checkbox"/> in parameter No. 2.	<input type="checkbox"/> 0 <input type="checkbox"/> <input type="checkbox"/> "interpolation axis control": The values of parameters No. 34 • 35 • 37 • 38 will change in subsequent operation.  <input type="checkbox"/> 2 <input type="checkbox"/> <input type="checkbox"/> "no": Auto tuning is made invalid to enable manual setting of parameters No. 6 • 35 to 38.
3	Set the following parameter of each axis to the minimum value of all interpolation-controlled axes: <ul style="list-style-type: none"> <li>• Parameter No. 6</li> </ul>	The gains for operation of all axes are set to the same value.

## 2. OPERATION

---

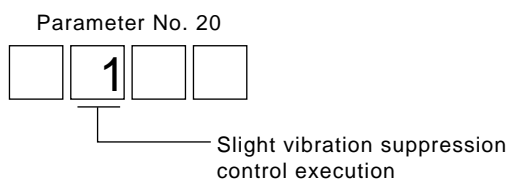
### 2-4-3 Slight vibration suppression control

The slight vibration suppression control mode is used to reduce servo-specific  $\pm 1$  pulse vibration at the time of a stop. This mode produces an effect especially when the ratio of load inertia moment to servo motor inertia moment is small (2 to 5 times). Note that when vibration is attributable to looseness (such as gear backlash) or machine resonance, use the machine resonance suppression filter in parameter No. 22. The slight vibration suppression control mode should be used after real-time auto tuning or manual gain adjustment.

#### Usage

First, perform real-time auto tuning or manual gain adjustment so that vibration falls within  $\pm 2$  to 3 pulses.

Set  1   in parameter No. 20 to enter the slight vibration suppression mode at the time of a stop.



# CHAPTER 3

## WIRING

---

This chapter provides information required for wiring of connectors, terminals, etc. Before doing wiring work, always read this chapter.

- 3-1 Servo amplifier
  - 3-1-1 Terminal blocks
  - 3-1-2 Signal connectors
  - 3-1-3 Detailed information on I/O signals
  - 3-1-4 Interfaces
- 3-2 Connection of servo amplifier and servo motor
  - 3-2-1 Connection instructions
  - 3-2-2 Connection diagram
  - 3-2-3 I/O terminals
  - 3-2-4 Connectors used for servo motor wiring
- 3-3 Common line
- 3-4 Grounding
- 3-5 Power supply circuit
- 3-6 Alarm occurrence timing chart
- 3-7 Servo motor with electromagnetic brake

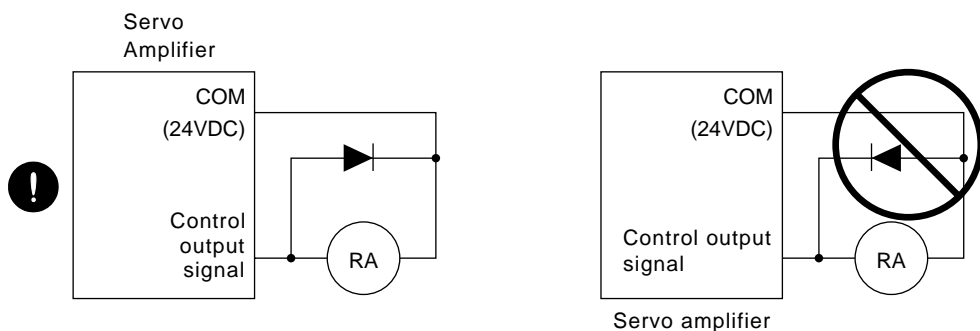
<b>INTRODUCTION</b>	<b>CHAPTER 1</b>
<b>OPERATION</b>	<b>CHAPTER 2</b>
<b>WIRING</b>	<b>CHAPTER 3</b>
<b>INSTALLATION</b>	<b>CHAPTER 4</b>
<b>ABSOLUTE POSITION DETECTION SYSTEM</b>	<b>CHAPTER 5</b>
<b>OPTIONS AND AUXILIARY EQUIPMENT</b>	<b>CHAPTER 6</b>
<b>INSPECTION</b>	<b>CHAPTER 7</b>
<b>TROUBLESHOOTING</b>	<b>CHAPTER 8</b>
<b>CHARACTERISTICS</b>	<b>CHAPTER 9</b>
<b>SPECIFICATIONS</b>	<b>CHAPTER 10</b>
<b>SELECTION</b>	<b>CHAPTER 11</b>

### 3.WIRING

#### WARNING

1. Any person who is involved in wiring should be fully competent to do the work.
2. Before starting wiring, make sure that the voltage is safe in the tester more than 10 minutes after power-off. Otherwise, you may get an electric shock.
3. Ground the servo amplifier and the servo motor securely.
4. Do not attempt to wire the servo amplifier and servo motor until they have been installed. Otherwise, you may get an electric shock.
5. The cables should not be damaged, stressed excessively, loaded heavily, or pinched. Otherwise, you may get an electric shock.

#### CAUTION



1. Wire the equipment correctly and securely. Otherwise, the servo motor may misoperate, resulting in injury.
2. Connect cables to correct terminals to prevent a burst, fault, etc.
3. Ensure that polarity (+, -) is correct. Otherwise, a burst, damage, etc. may occur.
4. The surge absorbing diode installed to the DC relay designed for control output should be fitted in the specified direction. Otherwise, the signal is not output due to a fault, disabling the emergency stop and other protective circuits.

5. Use a noise filter, etc. to minimize the influence of electromagnetic interference, which may be given to electronic equipment used near the servo amplifier.
6. Do not install a power capacitor, surge suppressor or radio noise filter (FR-BIF option) with the power line of the servo motor.
7. When using the regenerative brake resistor, switch power off with the alarm signal. Otherwise, a transistor fault or the like may overheat the regenerative brake resistor, causing a fire.
8. Do not modify the equipment.

#### NOTICE

CN1A, CN1B, CN2 and CN3 have the same shape. Wrong connection of the connectors will lead to a failure. Connect them correctly.

# 3.WIRING

## 3-1 Servo amplifier

**⚠ CAUTION** Only the specified voltage should be applied to each terminal. Otherwise, a burst, damage, etc. may occur.

### 3-1-1 Terminal blocks


(1) Signal arrangement

Terminal block signals are as listed below:

Servo Amplifiers		MR-J2-10A to MR-J2-60A	MR-J2-10A1 to MR-J2-40A1	MR-J2-70A MR-J2-100A	MR-J2-200A MR-J2-350A	
Terminals						
Terminal positions						
Terminal signals	1) Control circuit terminal block (TE2)	<p>(Phoenix Contact make)</p>		<p>(Phoenix Contact make)</p>		
	2) Main circuit terminal block (TE1)					
	3) Protective earth (PE) terminals					

### 3.WIRING

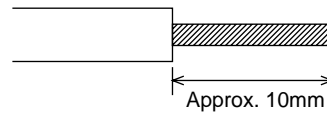
#### (2) Signals

Symbol	Signal	Description																				
L1, L2, L3	Main circuit power supply	<p>Main circuit power input terminals Supply L1, L2 and L3 with the following power: For single-phase 230VAC, connect the power supply to L1/L2 and leave L3 open.</p> <table border="1"> <tr> <td>Servo amplifier</td> <td>MR-J2-10A to 70A</td> <td>MR-J2-100A to 350A</td> <td>MR-J2-10A1 to 40A1</td> </tr> <tr> <td>Power supply</td> <td colspan="3">L1•L2•L3</td> </tr> <tr> <td>3-phase 200 to 230VAC, 50/60Hz</td> <td colspan="3">L1•L2</td> </tr> <tr> <td>(Note) Single-phase 230VAC, 50/60Hz</td> <td colspan="3">L1•L2</td> </tr> <tr> <td>Single-phase 100 to 120VAC, 50/60Hz</td> <td colspan="3">L1•L2</td> </tr> </table> <p>Note: Cannot be used for combination with the servo motor HC-SF52.</p>	Servo amplifier	MR-J2-10A to 70A	MR-J2-100A to 350A	MR-J2-10A1 to 40A1	Power supply	L1•L2•L3			3-phase 200 to 230VAC, 50/60Hz	L1•L2			(Note) Single-phase 230VAC, 50/60Hz	L1•L2			Single-phase 100 to 120VAC, 50/60Hz	L1•L2		
Servo amplifier	MR-J2-10A to 70A	MR-J2-100A to 350A	MR-J2-10A1 to 40A1																			
Power supply	L1•L2•L3																					
3-phase 200 to 230VAC, 50/60Hz	L1•L2																					
(Note) Single-phase 230VAC, 50/60Hz	L1•L2																					
Single-phase 100 to 120VAC, 50/60Hz	L1•L2																					
L11, L21	Control circuit power supply	<p>Control circuit power input terminals Supply L11 and L21 with the following power:</p> <table border="1"> <tr> <td>Servo amplifier</td> <td>MR-J2-10A to 350A</td> <td>MR-J2-10A1 to 40A1</td> </tr> <tr> <td>Power supply</td> <td colspan="2">L11•L21</td> </tr> <tr> <td>Single-phase 200 to 230VAC, 50/60Hz</td> <td colspan="2">L11•L21</td> </tr> <tr> <td>Single-phase 100 to 120VAC, 50/60Hz</td> <td colspan="2">L11•L21</td> </tr> </table> <p>L11 and L21 should be in phase with L1 and L2, respectively.</p>	Servo amplifier	MR-J2-10A to 350A	MR-J2-10A1 to 40A1	Power supply	L11•L21		Single-phase 200 to 230VAC, 50/60Hz	L11•L21		Single-phase 100 to 120VAC, 50/60Hz	L11•L21									
Servo amplifier	MR-J2-10A to 350A	MR-J2-10A1 to 40A1																				
Power supply	L11•L21																					
Single-phase 200 to 230VAC, 50/60Hz	L11•L21																					
Single-phase 100 to 120VAC, 50/60Hz	L11•L21																					
P, C, D	Regenerative brake option	<p>Regenerative brake option connection terminals C and D are factory-connected. When using the regenerative brake option, always remove wiring from across P-D and connect the regenerative brake option across P-C.</p>																				
U, V, W	Servo motor output	Servo motor power output terminals Connect to the servo motor power supply terminals (U, V, W).																				
N		Do not connect.																				
	Protective earth (PE)	Ground terminal Connect this terminal to the protective earth (PE) terminals of the servo motor and control box for grounding.																				

#### (3) How to use the control circuit terminal block (Phoenix Contact make)

##### 1) Termination of the cables

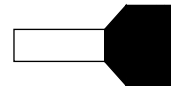
**Solid wire:** After the sheath has been stripped, the cable can be used as it is. (Cable size: 0.2 to 2.5mm<sup>2</sup>)



**Twisted wire:** Use the cable after stripping the sheath and twisting the core. At this time, take care to avoid a short caused by the loose wires of the core and the adjacent pole. Do not solder the core as it may cause a contact fault. (Cable size: 0.2 to 2.5mm<sup>2</sup>)  
Alternatively, a bar terminal may be used to put the wires together. (Phoenix Contact make)



Bar terminal for 1 cable



Bar terminal for 2 cables

(Bar terminal ferrule with insulation sleeve)

(Twin ferrule with insulation sleeve)

Cable Size		Bar Terminal Type		Crimping Tool
[mm <sup>2</sup> ]	AWG	For 1 cable	For 2 cables	
0.25	24	AI0.25-6YE		CRIMPFOX-UD6
		AI0.25-8YE		
0.5	20	AI0.5-6WH		
		AI0.5-8WH		
0.75	18	AI0.75-6GY	AI-TWIN2×0.75-8GY	
		AI0.75-8GY	AI-TWIN2×0.75-10GY	
1	18	AI1-6RD	AI-TWIN2×1-8RD	
		AI1-8RD	AI-TWIN2×1-10RD	
1.5	16	AI1.5-6BK	AI-TWIN2×1.5-8BK	
		AI1.5-8BK	AI-TWIN2×1.5-12BK	
2.5	14	AI2.5-8BU	AI-TWIN2×2.5-10BU	
		AI2.5-8BU-1000	AI-TWIN2×2.5-13BU	

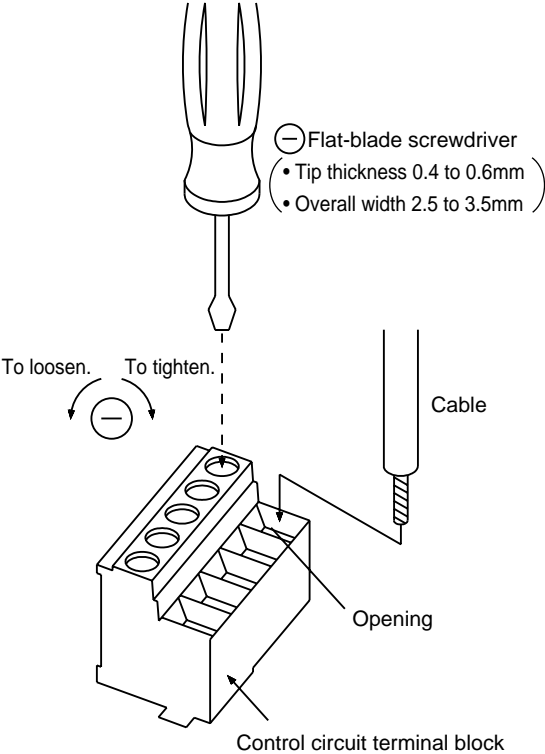


# 3.WIRING

## 2) Connection

Insert the core of the cable into the opening and tighten the screw with a flat-blade screwdriver so that the cable does not come off. (Tightening torque: 0.5 to 0.6N·m)  
Before inserting the cable into the opening, make sure that the screw of the terminal is fully loose.

When using a cable of 1.5mm<sup>2</sup> or less, two cables may be inserted into one opening.

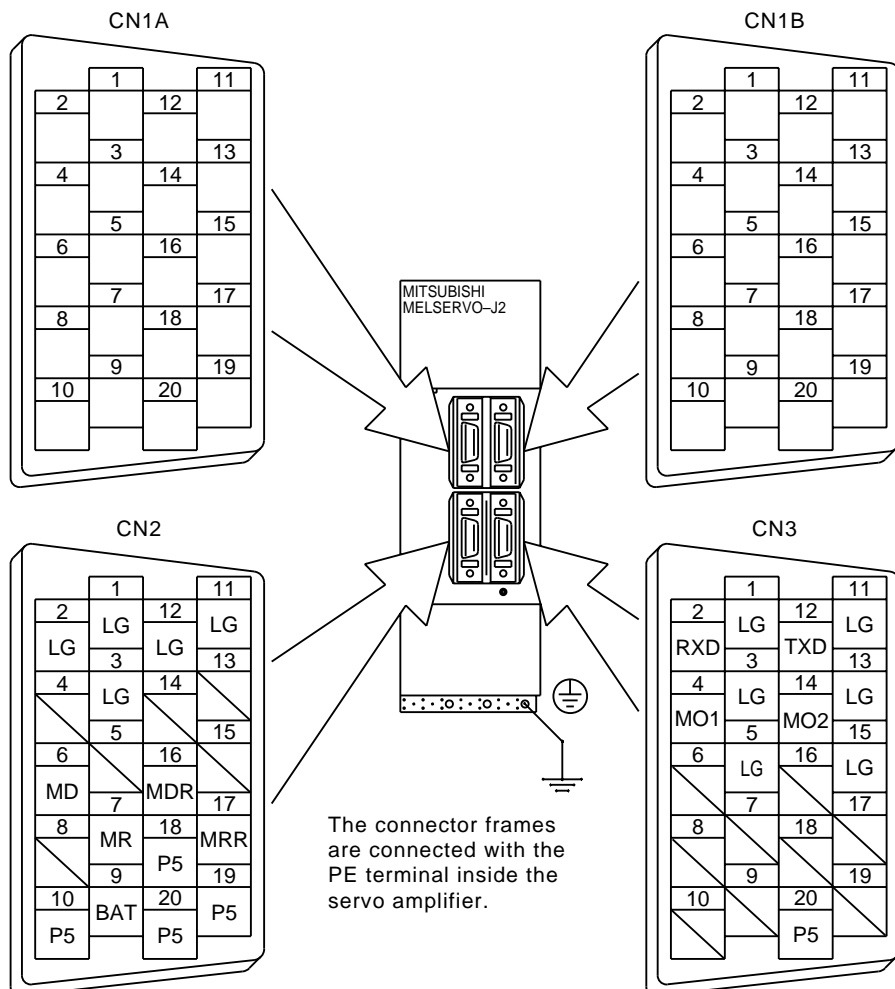


### 3.WIRING

#### 3-1-2 Signal connectors

##### (1) Signal arrangement

All connectors are half-pitch connectors (Molex 52986-2011 or equivalent). CN1A and CN1B signals change with the control mode. Refer to (2) in this section.



#### MEMORANDUM

The connector pin-outs shown above are viewed from the cable connector wiring section side.

### 3.WIRING

#### (2) CN1A and CN1B signal assignment

#### Pin assignment

Connector	Pin No.	Signal Input/Output (Note 1) I/O	(Note 2) Symbols of I/O Signals in Control Modes					
			P	P/S	S	S/T	T	T/P
CN1A	1		LG	LG	LG	LG	LG	LG
	2	I	NP	NP/×				×/NP
	3	I	PP	PP/×				×/PP
	4		P15R	P15R/P15R	P15R	P15R	P15R	P15R
	5	O	LZ	LZ	LZ	LZ	LZ	LZ
	6	O	LA	LA	LA	LA	LA	LA
	7	O	LB	LB	LB	LB	LB	LB
	(Note 8)8	I	CR	CR/SP1	(Note 3)SP1	SP1/SP1	(Note 3)SP1	SP1/CR
	9		COM	COM	COM	COM	COM	COM
	10		SG	SG	SG	SG	SG	SG
	11		OPC	OPC/×				×/OPC
	12	I	NG	NG/×				×/NG
	13	I	PG	PG/×				×/PG
	14	O	OP	OP	OP	OP	OP	OP
	15	O	LZR	LZR	LZR	LZR	LZR	LZR
	16	O	LAR	LAR	LAR	LAR	LAR	LAR
	17	O	LBR	LBR	LBR	LBR	LBR	LBR
	(Note 7, 9)18	O	INP	INP/SA	SA	SA/×		×/INP
	(Note 7, 9)19	O	RD	RD	RD	RD	RD	RD
	20		SG	SG	SG	SG	SG	SG
CN1B	1		LG	LG	LG	LG	LG	LG
	2	I		×/VC	VC	VC/VLA	VLA	VLA/×
	3		VDD	VDD	VDD	VDD	VDD	VDD
	(Note 4)10	O	DO1	DO1	DO1	DO1	DO1	DO1
	(Note 8)5	I	SON	SON	SON	SON	SON	SON
	(Note 7)6	O	TLC	TLC	TLC	TLC/VLC	VLC	VLC/TLC
	(Note 8)7	I		LOP	SP2	LOP	SP2	LOP
	(Note 8)8	I	PC	PC/ST1	(Note 4)ST1	ST1/RS2	(Note 4)RS2	RS2/PC
	(Note 8)9	I	TL	TL/ST2	(Note 5)ST2	ST2/RS1	(Note 5)RS1	RS1/TL
	10		SG	SG	SG	SG	SG	SG
	11		P15R	P15R	P15R	P15R	P15R	P15R
	12	I	TLA	TLA/TLA(Note 6)	(Note 6)TLA	(Note 6)TLA/TC	TC	TC/TLA
	13		COM	COM	COM	COM	COM	COM
	(Note 8)14	I	RES	RES	RES	RES	RES	RES
	15	I	EMG	EMG	EMG	EMG	EMG	EMG
	16	I	LSP	LSP	LSP	LSP/×		×/LSP
	17	I	LSN	LSN	LSN	LSN/×		×/LSN
	(Note 7)18	O	ALM	ALM	ALM	ALM	ALM	ALM
	(Note 7, 9, 11)19	O	ZPS	ZSP	ZSP	ZSP	ZSP	ZSP
	20		SG	SG	SG	SG	SG	SG

For notes, refer to the next page.

### 3.WIRING

- Note: 1. I: Input signal, O: Output signal, -: Others (e.g. power)  
 2. P: Position control mode, S: Speed control mode, T: Torque control mode, P/S: Position/speed control change mode, S/T: Speed/torque control change mode, T/P: Torque/position control change mode  
 3. Set parameter No. 45 to use CR.  
 4. Set parameter No. 47 to use PC.  
 5. Set parameter No. 48 to use TL.  
 6. By setting parameters No. 43 to 48 to make TL available, TLA can be used.  
 7. Set parameter No. 49 to use WNG and BWNG.  
 8. Set parameters No. 43 to 48 to change signals.  
 9. Set parameter No. 49 to select alarm codes. (Refer to Chapter 8.)  
 10. The signal of CN1A-18 is always output.  
 11. Set parameter No. 1 to select MBR.

#### (3) Symbols and signal names

Symbol	Signal Name	Symbol	Signal Name
SON	Servo on	VLC	Limiting speed
LSP	Forward rotation stroke end	RD	Ready
LSN	Reverse rotation stroke end	ZSP	Zero speed
CR	Clear	INP	In position
SP1	Speed selection 1	SA	Speed reached
SP2	Speed selection 2	ALM	Trouble
PC	Proportion control	WNG	Warning
ST1	Forward rotation start	BWNG	Battery warning
ST2	Reverse rotation start	OP	Encoder Z-phase pulse (open collector)
TL	Torque limit selection	MBR	Electromagnetic brake interlock
RES	Reset	LZ	Encoder Z-phase pulse
EMG	Emergency stop	LZR	(differential line driver)
LOP	Control change	LA	Encoder A-phase pulse
VC	Analog speed command	LAR	(differential line driver)
VLA	Analog speed limit	LB	Encoder B-phase pulse
TLA	Analog torque limit	LBR	(differential line driver)
TC	Analog torque command	MO1	Analog Monitor output 1
RS1	Forward rotation selection	MO2	Analog Monitor output 2
RS2	Reverse rotation selection	VDD	I/F internal power supply
PP	Forward/reverse rotation pulse train	COM	Digital I/F power supply input
NP		OPC	Open collector power input
PG		SG	Digital I/F common
NG		P15R	DC15V power supply
TLC	Limiting torque	LG	Control common
		SD	Shield

### 3.WIRING

#### (4) Signal explanations

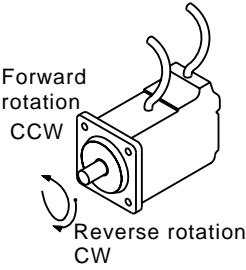
In the Control Mode field of the table

○ : Denotes that the signal may be used in the initial setting status.

△ : Denotes that the signal may be used by setting the corresponding parameter among parameters No. 1 and 43 to 49.

The pin No. in the connector pin No. column is the number under initial status.

#### 1) Input signals

Signal	Symbol	Connector Pin No.	Functions/Applications	I/O Division (Note 1)	Control Mode (Note 2)																																
					P	S	T																														
Servo on	SON	CN1B 5	Connect SON-SG to switch on the base circuit and make the servo amplifier ready to operate (servo on). Disconnect SON-SG to shut off the base circuit (servo off) and coast the servo motor. Set <input type="checkbox"/> <input type="checkbox"/> <input type="checkbox"/> 1 in parameter No. 41 to switch this signal on (keep terminals connected) automatically in the servo amplifier.	DI-1	○	○	○																														
Reset	RES	CN1B 14	Disconnect RES-SG for more than 50ms to reset the alarm. During alarm resetting, the base circuit is shut off. The following alarms cannot be reset:  <table border="1" style="display: inline-table; margin-right: 20px;"> <thead> <tr> <th>Dis-play</th> <th>Name</th> </tr> </thead> <tbody> <tr><td>A. 11</td><td>Board error 1</td></tr> <tr><td>A. 12</td><td>Memory error 1</td></tr> <tr><td>A. 13</td><td>Clock error</td></tr> <tr><td>A. 15</td><td>Memory error 2</td></tr> <tr><td>A. 16</td><td>Encoder error 1</td></tr> <tr><td>A. 17</td><td>Board error 2</td></tr> <tr><td>A. 18</td><td>Board error 3</td></tr> </tbody> </table> <table border="1" style="display: inline-table;"> <thead> <tr> <th>Dis-play</th> <th>Name</th> </tr> </thead> <tbody> <tr><td>A. 20</td><td>Encoder error 2</td></tr> <tr><td>A. 25</td><td>Absolute position erase</td></tr> <tr><td>A. 30</td><td>Regenerative error</td></tr> <tr><td>A. 37</td><td>Parameter error</td></tr> <tr><td>A. 50</td><td>Overload 1</td></tr> <tr><td>A. 51</td><td>Overload 2</td></tr> </tbody> </table> Also, the regenerative error (A. 30) and overload 1 (A. 50) cannot be reset until the regenerative brake resistor and power transistor are cooled to proper temperatures, respectively. If the line between RES and SG is short-circuited during the operation and no alarm is given, the status will come to the base and the servo motor will freely run to a stop.	Dis-play	Name	A. 11	Board error 1	A. 12	Memory error 1	A. 13	Clock error	A. 15	Memory error 2	A. 16	Encoder error 1	A. 17	Board error 2	A. 18	Board error 3	Dis-play	Name	A. 20	Encoder error 2	A. 25	Absolute position erase	A. 30	Regenerative error	A. 37	Parameter error	A. 50	Overload 1	A. 51	Overload 2	DI-1	○	○	○
Dis-play	Name																																				
A. 11	Board error 1																																				
A. 12	Memory error 1																																				
A. 13	Clock error																																				
A. 15	Memory error 2																																				
A. 16	Encoder error 1																																				
A. 17	Board error 2																																				
A. 18	Board error 3																																				
Dis-play	Name																																				
A. 20	Encoder error 2																																				
A. 25	Absolute position erase																																				
A. 30	Regenerative error																																				
A. 37	Parameter error																																				
A. 50	Overload 1																																				
A. 51	Overload 2																																				
Forward rotation stroke end	LSP	CN1B 16	The forward and/or reverse rotation stroke end signal must be ON to run the servo motor. If the signal is switched off, the servo motor will stop suddenly and servo-locked. By setting <input type="checkbox"/> <input type="checkbox"/> <input type="checkbox"/> 1 in parameter No. 22, the servo motor will come to a slow stop when the signal is switched off. Relationships between signal status and operation are as follows:  <table border="1" style="display: inline-table; margin-right: 20px;"> <thead> <tr> <th rowspan="2">Across LSP-SG</th> <th rowspan="2">Across LSN-SG</th> <th colspan="2">Operation</th> </tr> <tr> <th>CCW direction</th> <th>CW direction</th> </tr> </thead> <tbody> <tr><td>Short</td><td>Short</td><td>○</td><td>○</td></tr> <tr><td>Open</td><td>Short</td><td style="border: none;"></td><td>○</td></tr> <tr><td>Short</td><td>Open</td><td>○</td><td style="border: none;"></td></tr> <tr><td>Open</td><td>Open</td><td style="border: none;"></td><td style="border: none;"></td></tr> </tbody> </table> 	Across LSP-SG	Across LSN-SG	Operation		CCW direction	CW direction	Short	Short	○	○	Open	Short		○	Short	Open	○		Open	Open			DI-1	○	○									
Across LSP-SG	Across LSN-SG	Operation																																			
		CCW direction	CW direction																																		
Short	Short	○	○																																		
Open	Short		○																																		
Short	Open	○																																			
Open	Open																																				
Reverse rotation stroke end	LSN	CN1B 17	Set parameter No. 41 as indicated below to switch on the signals (keep terminals connected) automatically in the servo amplifier:  <table border="1" style="display: inline-table;"> <thead> <tr> <th>Parameter No. 41</th> <th>Automatic ON</th> </tr> </thead> <tbody> <tr> <td><input type="checkbox"/><input type="checkbox"/> 1 <input type="checkbox"/></td> <td>LSP</td> </tr> <tr> <td><input type="checkbox"/> 1 <input type="checkbox"/><input type="checkbox"/></td> <td>LSN</td> </tr> </tbody> </table>	Parameter No. 41	Automatic ON	<input type="checkbox"/> <input type="checkbox"/> 1 <input type="checkbox"/>	LSP	<input type="checkbox"/> 1 <input type="checkbox"/> <input type="checkbox"/>	LSN																												
Parameter No. 41	Automatic ON																																				
<input type="checkbox"/> <input type="checkbox"/> 1 <input type="checkbox"/>	LSP																																				
<input type="checkbox"/> 1 <input type="checkbox"/> <input type="checkbox"/>	LSN																																				

Note: 1. Refer to Section 3-1-4.

2. P: Position control mode, S: Speed control mode, T: Torque control mode

### 3.WIRING

Signal	Symbol	Connector Pin No.	Functions/Applications	I/O Division (Note 1)	Control Mode (Note 2)																						
					P	S	T																				
Torque limit	TL	CN1B 9	Connect TL-SG to limit torque according to the voltage level (max. torque: +8V) of analog torque limit (TLA).  <table border="1"> <thead> <tr> <th>Across TL-SG</th> <th colspan="2">Torque Limit</th> </tr> </thead> <tbody> <tr> <td>Open</td> <td colspan="2">Internal torque limit 1 (parameter No. 28)</td> </tr> <tr> <td rowspan="3">Short</td> <td>Torque limit relationship</td> <td>Valid torque limit</td> </tr> <tr> <td>Analog torque limit &lt; internal torque limit 1</td> <td>Analog torque limit</td> </tr> <tr> <td>Analog torque limit &gt; internal torque limit 1</td> <td>Internal torque limit 1</td> </tr> </tbody> </table>	Across TL-SG	Torque Limit		Open	Internal torque limit 1 (parameter No. 28)		Short	Torque limit relationship	Valid torque limit	Analog torque limit < internal torque limit 1	Analog torque limit	Analog torque limit > internal torque limit 1	Internal torque limit 1	DI-1										
				Across TL-SG	Torque Limit																						
Open	Internal torque limit 1 (parameter No. 28)																										
Short	Torque limit relationship	Valid torque limit																									
	Analog torque limit < internal torque limit 1	Analog torque limit																									
	Analog torque limit > internal torque limit 1	Internal torque limit 1																									
Forward rotation start	ST1	CN1B 8	Used to start the servo motor in any of the following directions:  <table border="1"> <thead> <tr> <th>Across ST1-SG</th> <th>Across ST2-SG</th> <th>Servo Motor Starting Direction</th> </tr> </thead> <tbody> <tr> <td>Open</td> <td>Open</td> <td>Stop (servo lock)</td> </tr> <tr> <td>Short</td> <td>Open</td> <td>CCW</td> </tr> <tr> <td>Open</td> <td>Short</td> <td>CW</td> </tr> <tr> <td>Short</td> <td>Short</td> <td>Stop (servo lock)</td> </tr> </tbody> </table>	Across ST1-SG	Across ST2-SG	Servo Motor Starting Direction	Open	Open	Stop (servo lock)	Short	Open	CCW	Open	Short	CW	Short	Short	Stop (servo lock)	DI-1								
Across ST1-SG	Across ST2-SG	Servo Motor Starting Direction																									
Open	Open	Stop (servo lock)																									
Short	Open	CCW																									
Open	Short	CW																									
Short	Short	Stop (servo lock)																									
Reverse rotation start	ST2	CN1B 9	If both ST1 and ST2 are switched on or off during operation, the servo motor will be decelerated to a stop according to the parameter No. 12 setting and servo-locked. When the analog speed command (VC) is 0V, starting the servo motor will not generate servo lock torque.																								
Forward rotation selection	RS1	CN1B 9	Used to select any of the following servo motor torque generation directions:  <table border="1"> <thead> <tr> <th>Across RS1-SG</th> <th>Across RS2-SG</th> <th>Torque Generation Direction</th> <th>Rotation Direction</th> </tr> </thead> <tbody> <tr> <td>Open</td> <td>Open</td> <td>No torque</td> <td>Stop</td> </tr> <tr> <td>Short</td> <td>Open</td> <td>Forward rotation in driving mode / reverse rotation in regenerative mode</td> <td>CCW</td> </tr> <tr> <td>Open</td> <td>Short</td> <td>Reverse rotation in driving mode / forward rotation in regenerative mode</td> <td>CW</td> </tr> <tr> <td>Short</td> <td>Short</td> <td>No torque</td> <td>Stop</td> </tr> </tbody> </table>	Across RS1-SG	Across RS2-SG	Torque Generation Direction	Rotation Direction	Open	Open	No torque	Stop	Short	Open	Forward rotation in driving mode / reverse rotation in regenerative mode	CCW	Open	Short	Reverse rotation in driving mode / forward rotation in regenerative mode	CW	Short	Short	No torque	Stop	DI-1			
Across RS1-SG	Across RS2-SG	Torque Generation Direction		Rotation Direction																							
Open	Open	No torque	Stop																								
Short	Open	Forward rotation in driving mode / reverse rotation in regenerative mode	CCW																								
Open	Short	Reverse rotation in driving mode / forward rotation in regenerative mode	CW																								
Short	Short	No torque	Stop																								
Reverse rotation selection	RS2	CN1B 8																									

Note: 1. Refer to Section 3-1-4.

2. P: Position control mode, S: Speed control mode, T: Torque control

### 3.WIRING

Signal	Symbol	Connector Pin No.	Speed Command	I/O Division (Note 1)	Control Mode (Note 2)										
					P	S	T								
Speed selection 1	SP1	CN1A 8	<Speed control mode> Used to select the command speed for operation.	DI-1											
			<table border="1"> <thead> <tr> <th>Across SP1-SG</th> <th>Across SP2-SG</th> <th>Functions/Applications</th> </tr> </thead> <tbody> <tr> <td>Open</td> <td>Open</td> <td>Analog speed command (VC)</td> </tr> <tr> <td>Short</td> <td>Open</td> <td>Internal speed command 1 (parameter No. 8)</td> </tr> <tr> <td>Open</td> <td>Short</td> <td>Internal speed command 2 (parameter No. 9)</td> </tr> <tr> <td>Short</td> <td>Short</td> <td>Internal speed command 3 (parameter No. 10)</td> </tr> </tbody> </table>					Across SP1-SG	Across SP2-SG	Functions/Applications	Open	Open	Analog speed command (VC)	Short	Open
Across SP1-SG	Across SP2-SG	Functions/Applications													
Open	Open	Analog speed command (VC)													
Short	Open	Internal speed command 1 (parameter No. 8)													
Open	Short	Internal speed command 2 (parameter No. 9)													
Short	Short	Internal speed command 3 (parameter No. 10)													
Speed selection 2	SP2	CN1B 7	<Torque control mode> Used to select the limit speed for operation.												
			<table border="1"> <thead> <tr> <th>Across SP1-SG</th> <th>Across SP2-SG</th> <th>Speed Limit</th> </tr> </thead> <tbody> <tr> <td>Open</td> <td>Open</td> <td>Analog speed limit (VLA)</td> </tr> <tr> <td>Short</td> <td>Open</td> <td>Internal speed limit 1 (parameter No. 8)</td> </tr> <tr> <td>Open</td> <td>Short</td> <td>Internal speed limit 2 (parameter No. 9)</td> </tr> <tr> <td>Short</td> <td>Short</td> <td>Internal speed limit 3 (parameter No. 10)</td> </tr> </tbody> </table>					Across SP1-SG	Across SP2-SG	Speed Limit	Open	Open	Analog speed limit (VLA)	Short	Open
Across SP1-SG	Across SP2-SG	Speed Limit													
Open	Open	Analog speed limit (VLA)													
Short	Open	Internal speed limit 1 (parameter No. 8)													
Open	Short	Internal speed limit 2 (parameter No. 9)													
Short	Short	Internal speed limit 3 (parameter No. 10)													
Speed selection 2	SP2	CN1B 7	<Position/speed, speed/torque, torque/position control change mode>  As CN1B-7 acts as a control change signal, the speed selected when the speed or torque control mode is selected is as follows:												
			<ul style="list-style-type: none"> <li>When speed control mode is selected</li> </ul> <table border="1"> <thead> <tr> <th>Across SP1-SG</th> <th>Speed Command</th> </tr> </thead> <tbody> <tr> <td>Open</td> <td>Analog speed command (VC)</td> </tr> <tr> <td>Short</td> <td>Internal speed command 1 (parameter No. 8)</td> </tr> </tbody> </table> <ul style="list-style-type: none"> <li>When torque control mode is selected</li> </ul> <table border="1"> <thead> <tr> <th>Across SP1-SG</th> <th>Speed Limit</th> </tr> </thead> <tbody> <tr> <td>Open</td> <td>Analog speed limit (VLA)</td> </tr> <tr> <td>Short</td> <td>Internal speed limit 1 (parameter No. 8)</td> </tr> </tbody> </table>					Across SP1-SG	Speed Command	Open	Analog speed command (VC)	Short	Internal speed command 1 (parameter No. 8)	Across SP1-SG	Speed Limit
Across SP1-SG	Speed Command														
Open	Analog speed command (VC)														
Short	Internal speed command 1 (parameter No. 8)														
Across SP1-SG	Speed Limit														
Open	Analog speed limit (VLA)														
Short	Internal speed limit 1 (parameter No. 8)														

Note: 1. Refer to Section 3-1-4.

2. P: Position control mode, S: Speed control mode, T: Torque control mode

### 3.WIRING

Signal	Symbol	Connector Pin No.	Functions/Applications	I/O Division (Note 1)	Control Mode (Note 2)																				
					P	S	T																		
Proportion control	PC	CN1B 8	Connect PC-SG to switch the speed amplifier from the proportional integral type to the proportional type. If the servo motor at a stop is rotated even one pulse due to any external factor, it generates torque to compensate for a position shift. When the servo motor shaft is to be locked mechanically after positioning completion (stop), switching on the proportion control signal (PC) upon positioning completion will suppress the unnecessary torque generated to compensate for a position shift. When the shaft is to be locked for a long time, switch on the proportion control signal and torque control signal (TL) at the same time to make the torque less than the rated by the analog torque limit.	DI-1	○	△																			
Emergency stop	EMG	CN1B 15	Disconnect EMG-SG to bring the servo motor to an emergency stop state, in which the servo is switched off and the dynamic brake is operated. Connect EMG-SG in the emergency stop state to reset that state.	DI-1	○	○	○																		
Clear	CR	CN1A 8	Connect CR-SG to clear the position control counter on the leading edge of the signal. The pulse width should be 10ms or more.	DI-1	○	△	△																		
Control change	LOP	CN1B 7	<p>&lt;Position/speed control change mode&gt; Used to select the control mode in the position/speed control change mode.</p> <table border="1"> <thead> <tr> <th>Across LOP-SG</th> <th>Control Mode</th> </tr> </thead> <tbody> <tr> <td>Open</td> <td>Position</td> </tr> <tr> <td>Short</td> <td>Speed</td> </tr> </tbody> </table> <p>&lt;Speed/torque control change mode&gt; Used to select the control mode in the speed/torque control change mode.</p> <table border="1"> <thead> <tr> <th>Across LOP-SG</th> <th>Control Mode</th> </tr> </thead> <tbody> <tr> <td>Open</td> <td>Speed</td> </tr> <tr> <td>Short</td> <td>Torque</td> </tr> </tbody> </table> <p>&lt;Torque/position control mode&gt; Used to select the control mode in the torque/position control change mode.</p> <table border="1"> <thead> <tr> <th>Across LOP-SG</th> <th>Control Mode</th> </tr> </thead> <tbody> <tr> <td>Open</td> <td>Torque</td> </tr> <tr> <td>Short</td> <td>Position</td> </tr> </tbody> </table>	Across LOP-SG	Control Mode	Open	Position	Short	Speed	Across LOP-SG	Control Mode	Open	Speed	Short	Torque	Across LOP-SG	Control Mode	Open	Torque	Short	Position	DI-1			
Across LOP-SG	Control Mode																								
Open	Position																								
Short	Speed																								
Across LOP-SG	Control Mode																								
Open	Speed																								
Short	Torque																								
Across LOP-SG	Control Mode																								
Open	Torque																								
Short	Position																								

Note: 1. Refer to Section 3-1-4.

2. P: Position control mode, S: Speed control mode, T: Torque control mode



### 3.WIRING

Signal	Symbol	Connector Pin No.	Functions/Applications	I/O Division (Note 1)	Control Mode (Note 2)		
					P	S	T
Analog torque limit	TLA	CN1B 12	<p><b>NOTICE</b> To use this signal in the speed control mode, set any of parameters No. 43 to 48 to make TL available.</p> <p>When the analog torque limit (TLA) is valid, torque is limited in the full servo motor output torque range. Apply 0 to +10 VDC across TLA-LG. Connect the positive terminal of the power supply to TLA. Maximum torque is generated at +10 V. (Refer to 1), (1) in Section 3-1-3.) Resolution: 10 bit</p>	Analog input	○	△	
Analog torque command	TC	CN1B 12	Used to control torque in the full servo motor output torque range. Apply -8 to +8VDC across TC-LG. Maximum torque is generated at +8V. (Refer to 1), (1) in Section 3-1-3.) Resolution: 10 bit	Analog input		△	○
Analog speed command	VC	CN1B 2	Apply -10 to +10VDC across VC-LG. Speed set in parameter No. 25 is provided at +10V. (Refer to 1), (2) in Section 3-1-3.) Resolution: 12 bit or equivalent	Analog input		○	
Analog speed limit	VLA	CN1B 2	Apply -10 to +10VDC across VLA-LG. Speed set in parameter No. 25 is provided at +10V. (Refer to 1), (3) in Section 3-1-3.) Resolution: 12 bit or equivalent	Analog input			○
Forward rotation pulse train Reverse rotation pulse train	PP NP PG NG	CN1A 3 CN1A 2 CN1A 13 CN1A 12	<p>Used to enter a command pulse train.</p> <ul style="list-style-type: none"> <li>In the open collector system (max. input frequency 200kpps):           <ul style="list-style-type: none"> <li>Forward rotation pulse train across PP-SG</li> <li>Reverse rotation pulse train across NP-SG</li> </ul> </li> <li>In the differential receiver system (max. input frequency 400kpps):           <ul style="list-style-type: none"> <li>Forward rotation pulse train across PG-PP</li> <li>Reverse rotation pulse train across NG-NP</li> </ul> </li> </ul> <p>The command pulse train form can be changed using parameter No. 21.</p>	DI-2	○		

Note: 1. Refer to Section 3-1-4.

2. P: Position control mode, S: Speed control mode, T: Torque control mode

### 3.WIRING

#### 2) Output signals

Signal	Symbol	Connector Pin No.	Functions/Applications	I/O Division (Note 1)	Control Mode (Note 2)		
					P	S	T
Trouble	ALM	CN1B 18	ALM-SG are disconnected when power is switched off or the protective circuit is activated to shut off the base circuit. Without alarm, ALM-SG are connected within 1 second after power on. Connect the regenerative brake option or the like with a temperature detector to make up a protective circuit.	DO-1	○	○	○
Ready	RD	CN1A 19	RD-SG are connected when the servo is switched on and the servo amplifier is ready to operate.	DO-1	○	○	○
In position	INP	CN1A 18	INP-SG are connected when the number of droop pulses is in the preset in-position range. The in-position range can be changed using parameter No. 5. When the in-position range is increased, INP-SG may be kept connected during low-speed rotation.	DO-1	○	/	/
Speed reached	SA	CN1A 18	SA-SG are connected when the servo motor speed has nearly reached the preset speed. When the preset speed is 50r/min or less, SA-SG are kept connected.	DO-1	/	○	/
Limiting speed	VLC	CN1B 6	VLC-SG are connected when speed reaches the value set to any of the internal speed limits 1 to 3 (parameters No. 8 to 10) or the analog speed limit (VLA) in the torque control mode. They are disconnected when the servo-on signal (SON) switches off.	DO-1	/	/	○
Zero speed	ZSP	CN1B 19	ZSP-SG are connected when the servo motor speed is zero speed (50r/min) or less. Zero speed can be changed using parameter No. 24.	DO-1	○	○	○
Limiting torque	TLC	CN1B 6	TLC-SG are connected when the torque generated reaches the value set to the internal torque limit 1 (parameter No. 28) or analog torque limit (TLA). They are disconnected when the servo-on signal (SON) switches off.	DO-1	○	○	/
Electromagnetic brake interlock	MBR	(CN1B 19)	<div style="border: 1px solid black; padding: 5px; margin-bottom: 10px;"> <p><b>NOTICE</b> Set <input type="checkbox"/><input type="checkbox"/><input type="checkbox"/> in parameter No. 1 to use this parameter. Note that ZSP will be made unavailable.</p> </div> <p>In the servo-off or alarm status, MBR-SG are disconnected. When an alarm occurs, they are disconnected at zero speed or less, independently of the base circuit status.</p>	DO-1	△	△	△
Warning	WNG	/	<div style="border: 1px solid black; padding: 5px; margin-bottom: 10px;"> <p><b>NOTICE</b> Set <input type="checkbox"/><input type="checkbox"/><input type="checkbox"/> in parameter No. 49 to use this signal.</p> </div> <p>When warning has occurred, WNG-SG are connected. When there is no warning, WNG-SG are disconnected within 1 second after power-on.</p>	DO-1	△	△	△

Note: 1. Refer to Section 3-1-4.

2. P: Position control mode, S: Speed control mode, T: Torque control mode

### 3.WIRING

Signal	Symbol	Connector Pin No.	Functions/Applications	I/O Division (Note 1)	Control Mode (Note 2)																																																																														
					P	S	T																																																																												
Battery warning	BWNG		<p><b>NOTICE</b> Set <input type="checkbox"/>1<input type="checkbox"/><input type="checkbox"/> in parameter No. 49 to use this signal.</p> <p>BWNG-SG are connected when battery cable breakage warning (A. 92) or battery warning (A. 9F) has occurred. When there is no battery warning, BWNG-SG are disconnected within 1 second after power-on.</p>	DO-1																																																																															
Alarm code		CN1A 19 CN1A 18 CN1B 19	<p><b>NOTICE</b> To use this signal, set <input type="checkbox"/><input type="checkbox"/><input type="checkbox"/>1 in parameter No. 49.</p> <p>This signal is output when an alarm occurs. When there is no alarm, respective ordinary signals (RD, INP, SA, ZSP) are output. Alarm codes and alarm names are listed below:</p> <table border="1"> <thead> <tr> <th colspan="3">(Note) Alarm Code</th> <th rowspan="2">Alarm Display</th> <th rowspan="2">Name</th> </tr> <tr> <th>CN1B 19 Pin</th> <th>CN1A 18 Pin</th> <th>CN1A 19 Pin</th> </tr> </thead> <tbody> <tr> <td rowspan="8">0</td> <td rowspan="8">0</td> <td rowspan="8">0</td> <td>8888</td> <td>Watchdog</td> </tr> <tr> <td>A. 11</td> <td>Board error 1</td> </tr> <tr> <td>A. 12</td> <td>Memory error 1</td> </tr> <tr> <td>A. 13</td> <td>Clock error</td> </tr> <tr> <td>A. 15</td> <td>Memory error 2</td> </tr> <tr> <td>A. 17</td> <td>Board error 2</td> </tr> <tr> <td>A. 18</td> <td>Board error 3</td> </tr> <tr> <td>A. 37</td> <td>Parameter error</td> </tr> <tr> <td rowspan="2">0</td> <td rowspan="2">0</td> <td rowspan="2">1</td> <td>A. 30</td> <td>Regenerative error</td> </tr> <tr> <td>A. 33</td> <td>Overvoltage</td> </tr> <tr> <td>0</td> <td>1</td> <td>0</td> <td>A. 10</td> <td>Undervoltage</td> </tr> <tr> <td rowspan="3">0</td> <td rowspan="3">1</td> <td rowspan="3">1</td> <td>A. 46</td> <td>Motor overheat</td> </tr> <tr> <td>A. 50</td> <td>Overload 1</td> </tr> <tr> <td>A. 51</td> <td>Overload 2</td> </tr> <tr> <td rowspan="2">1</td> <td rowspan="2">0</td> <td rowspan="2">0</td> <td>A. 24</td> <td>Motor output ground fault</td> </tr> <tr> <td>A. 32</td> <td>Acceleration</td> </tr> <tr> <td rowspan="2">1</td> <td rowspan="2">0</td> <td rowspan="2">1</td> <td>A. 31</td> <td>Overspeed</td> </tr> <tr> <td>A. 35</td> <td>Command pulse frequency alarm</td> </tr> <tr> <td rowspan="3">1</td> <td rowspan="3">1</td> <td rowspan="3">0</td> <td>A. 52</td> <td>Error excessive</td> </tr> <tr> <td>A. 16</td> <td>Encoder error 1</td> </tr> <tr> <td>A. 20</td> <td>Encoder error 2</td> </tr> <tr> <td></td> <td></td> <td></td> <td>A. 25</td> <td>Absolute position erase</td> </tr> </tbody> </table> <p>Note: 0: Each pin and SG are disconnected (OFF). 1: Each pin and SG are connected (ON)</p>	(Note) Alarm Code			Alarm Display	Name	CN1B 19 Pin	CN1A 18 Pin	CN1A 19 Pin	0	0	0	8888	Watchdog	A. 11	Board error 1	A. 12	Memory error 1	A. 13	Clock error	A. 15	Memory error 2	A. 17	Board error 2	A. 18	Board error 3	A. 37	Parameter error	0	0	1	A. 30	Regenerative error	A. 33	Overvoltage	0	1	0	A. 10	Undervoltage	0	1	1	A. 46	Motor overheat	A. 50	Overload 1	A. 51	Overload 2	1	0	0	A. 24	Motor output ground fault	A. 32	Acceleration	1	0	1	A. 31	Overspeed	A. 35	Command pulse frequency alarm	1	1	0	A. 52	Error excessive	A. 16	Encoder error 1	A. 20	Encoder error 2				A. 25	Absolute position erase	DO-1			
(Note) Alarm Code			Alarm Display	Name																																																																															
CN1B 19 Pin	CN1A 18 Pin	CN1A 19 Pin																																																																																	
0	0	0	8888	Watchdog																																																																															
			A. 11	Board error 1																																																																															
			A. 12	Memory error 1																																																																															
			A. 13	Clock error																																																																															
			A. 15	Memory error 2																																																																															
			A. 17	Board error 2																																																																															
			A. 18	Board error 3																																																																															
			A. 37	Parameter error																																																																															
0	0	1	A. 30	Regenerative error																																																																															
			A. 33	Overvoltage																																																																															
0	1	0	A. 10	Undervoltage																																																																															
0	1	1	A. 46	Motor overheat																																																																															
			A. 50	Overload 1																																																																															
			A. 51	Overload 2																																																																															
1	0	0	A. 24	Motor output ground fault																																																																															
			A. 32	Acceleration																																																																															
1	0	1	A. 31	Overspeed																																																																															
			A. 35	Command pulse frequency alarm																																																																															
1	1	0	A. 52	Error excessive																																																																															
			A. 16	Encoder error 1																																																																															
			A. 20	Encoder error 2																																																																															
			A. 25	Absolute position erase																																																																															

Note: 1. Refer to Section 3-1-4.

2. P: Position control mode, S: Speed control mode, T: Torque control mode

### 3.WIRING

Signal	Symbol	Connector Pin No.	Functions/Applications	I/O Division (Note 1)	Control Mode (Note 2)		
					P	S	T
Encoder Z-phase pulse (Open collector)	OP	CN1A 14	Outputs the zero-point signal of the encoder. One pulse is output per servo motor revolution. OP and LG are connected when the zero-point position is reached. ( Negative logic) Min. pulse width is about 800μs. For zeroing using this pulse, set the creep speed to 100r/min. or less.	DO-2	<input type="radio"/>	<input type="radio"/>	<input type="radio"/>
Encoder A-phase pulse (Differential line driver)	LA	CN1A 6	Outputs pulses per servo motor revolution set in parameter No. 27 in the differential line driver system. The encoder B-phase pulse lags the encoder A-phase pulse by a phase angle of $\pi/2$ .	DO-2	<input type="radio"/>	<input type="radio"/>	<input type="radio"/>
Encoder B-phase pulse (Differential line driver)	LAR LB LBR	CN1A 16 CN1A 7 CN1A 17					
Encoder Z-phase pulse (Differential line driver)	LZ LZR	CN1A 5 CN1A 15	The same signal as OP is output in the differential line driver system.	DO-2	<input type="radio"/>	<input type="radio"/>	<input type="radio"/>
Analog Monitor output 1	MO1	CN3 4	Data specified for CH1 in parameter No. 17 is output to across MO1-LG in analog form.	Analog output	<input type="radio"/>	<input type="radio"/>	<input type="radio"/>
Analog Monitor output 2	MO2	CN3 14	Data specified for CH2 in parameter No. 17 is output to across MO2-LG in analog form.	Analog output	<input type="radio"/>	<input type="radio"/>	<input type="radio"/>

Note: 1. Refer to Section 3-1-4.

2. P: Position control mode, S: Speed control mode, T: Torque control mode

### 3.WIRING

#### 3) Power supply

Signal	Symbol	Connector Pin No.	Functions/Applications	I/O Division (Note 1)	Control Mode (Note 2)		
					P	S	T
I/F internal power supply	VDD	CN1B 3	Used to output 24VDC for input interface. Connect with COM to use this power supply. Permissible current: 80mA		<input type="radio"/>	<input type="radio"/>	<input type="radio"/>
Digital I/F power supply input	COM	CN1A 9 CN1B 13	Used to input 24VDC for input interface. Connect the positive terminal of the 24VDC external power supply. Connect with VDD to use the internal power supply. 24VDC±10%		<input type="radio"/>	<input type="radio"/>	<input type="radio"/>
Open collector power input	OPC	CN1A 11	When inputting a pulse train in the open collector system, supply this terminal with the positive (+) power of 24VDC.		<input type="radio"/>	<input type="radio"/>	<input type="radio"/>
Digital I/F common	SG	CN1A 10 20 CN1B 10 20	Common terminal for VDD and COM. Pins are connected internally. Separated from LG.		<input type="radio"/>	<input type="radio"/>	<input type="radio"/>
DC15V power supply	P15R	CN1A 4 CN1B 11	Used to output 15VDC. Available as power for TC, TLA, VC, VLA. Permissible current: 30mA		<input type="radio"/>	<input type="radio"/>	<input type="radio"/>
Control common	LG	CN1A 1 CN1B 1 CN3 1 3 5 11 13 15	Common terminal for TLA, TC, VC, VLA, FPA, FPB, OP, MO1, MO2 and P15R. Pins are connected internally.		<input type="radio"/>	<input type="radio"/>	<input type="radio"/>
Shield	SD	Plate	Connect the external conductor of the shield cable.		<input type="radio"/>	<input type="radio"/>	<input type="radio"/>

Note: 1. Refer to Section 3-1-4.

2. P: Position control mode, S: Speed control mode, T: Torque control mode

# 3.WIRING

## 3-1-3 Detailed information on I/O signals

### (1) Position control mode

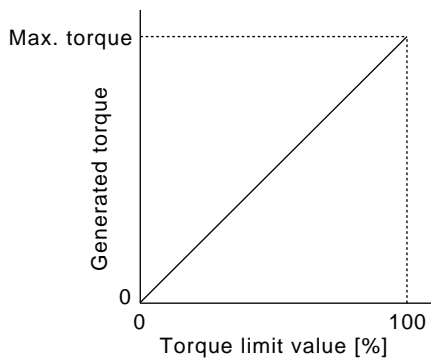
#### 1) Torque limit

##### a. Torque limit and generated torque

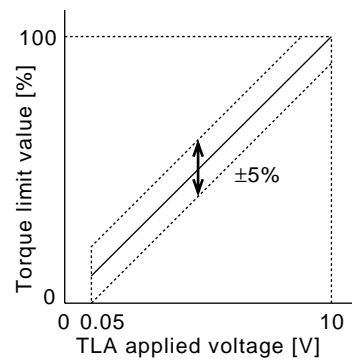
By setting parameter No. 28 (internal torque limit 1), torque is always limited to the maximum value during operation. A relationship between limit value and servo motor-generated torque is shown in Fig. 3-1.

A relationship between the applied voltage of the analog torque limit (TLA) and the torque limit value of the servo motor is shown in Fig. 3-2. Generated torque limit values will vary about 5% relative to the voltage depending on products.

At the voltage of less than 0.05V, generated torque may vary as it may not be limited sufficiently. Therefore, use this function at the voltage of 0.05V or more.



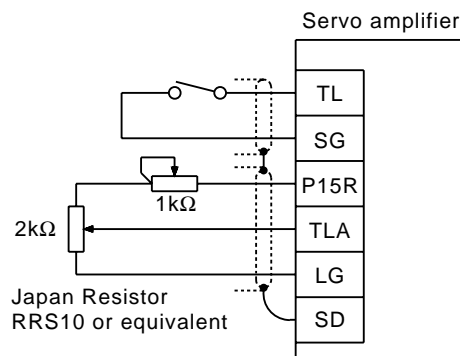
**Fig. 3-1 Torque Limit Value vs. Generated Torque**



**Fig. 3-2 TLA Applied Voltage vs. Torque Limit Value**

##### b. Connection diagram

Connect as shown in Fig. 3-3.



**Fig. 3-3 Connection Example**

### 3.WIRING

c. Torque limit signal (TL) and valid torque limit

Use the torque limit signal (TL) to select the torque limit made valid by internal torque limit 1 or analog torque limit (TLA) as indicated in Table 3-1:

Table 3-1 TL and Valid Torque Limit Value

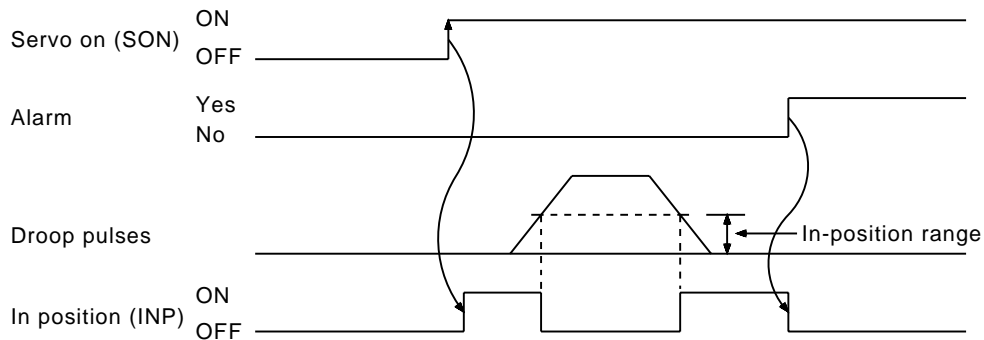
Across TL-SG	Valid Torque Limit Value
Open	Internal torque limit 1 (parameter No. 28)
Short	Analog torque limit (TLA) if analog torque limit (TLA) < internal
	torque limit 1Internal torque limit 1 (TL1) if analog torque limit (TLA) > internal torque limit 1

d. Limiting torque (TLC)

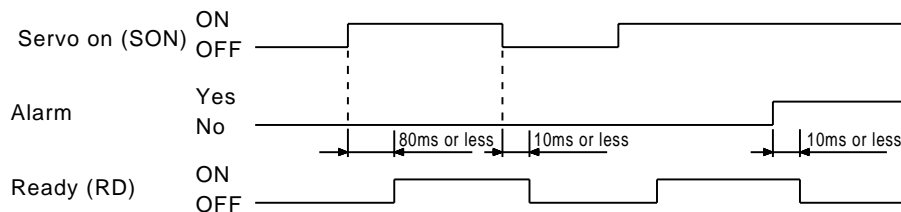
TLC-SG are connected when the torque generated by the servo motor reaches the torque set to internal torque limit 1 or analog torque limit.

2) In position (INP)

PF-SG are connected when the number of droop pulses in the deviation counter falls within the preset in-position range (parameter No. 5). When the in-position range setting is large, PF-SG may remain connected during low-speed operation.





3) Ready (RD)

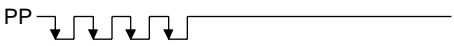
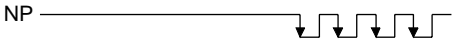
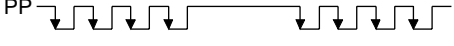


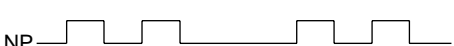
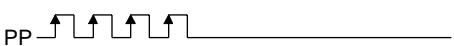



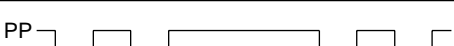
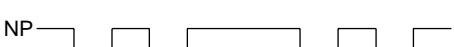










### 3.WIRING

#### 4) Pulse train input

Encoder pulses can be input in any of three different forms and are available in positive or negative logic. Use parameter No. 21 to set the command pulse train form.

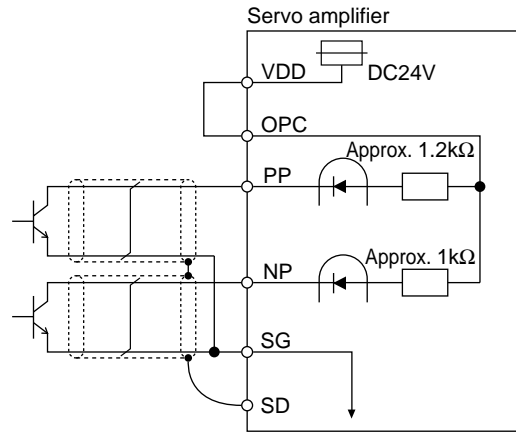
The arrow  or  in the following table indicates the timing of importing the pulse train.

Pulse Train Form		For Forward Rotation	For Reverse Rotation	Parameter No. 21
<b>Negative logic</b>	Forward rotation pulse train Reverse rotation pulse train	PP 	NP 	0010
	Pulse train + sign	PP  NP 	PP  NP 	0011
	A-phase pulse train B-phase pulse train	PP  NP 	PP  NP 	0012
<b>Positive logic</b>	Forward rotation pulse train	PP 	NP 	0000
	Pulse train + sign	PP  NP 	PP  NP 	0001
	A-phase pulse train B-phase pulse train	PP  NP 	PP  NP 	0002

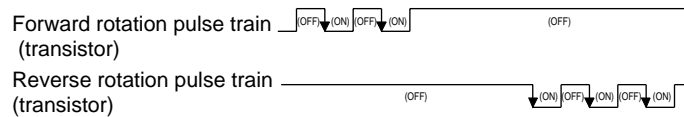


### 3.WIRING

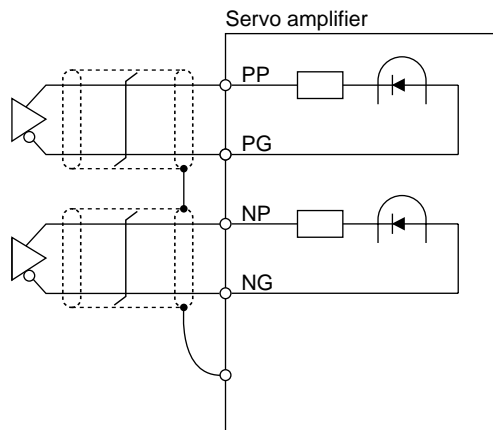
#### a. Open collector system



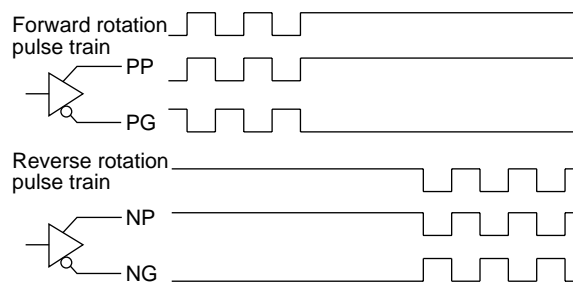
The explanation assumes that the input waveform has been set to the negative logic and forward and reverse rotation pulse trains (parameter No.21 has been set to 0010). The waveforms in the table on the preceding page are voltage waveforms of PP and NP based on SG. Their relationships with transistor ON/OFF are as follows:



#### b. Differential line driver system



The explanation assumes that the input waveform has been set to the negative logic and forward and reverse rotation pulse trains (parameter No.21 has been set to 0010). In the differential line driver system, the waveforms in the table on the preceding page are as follows. The waveforms of PP, PG, NP and NG are waveforms based on the ground of the differential line driver.



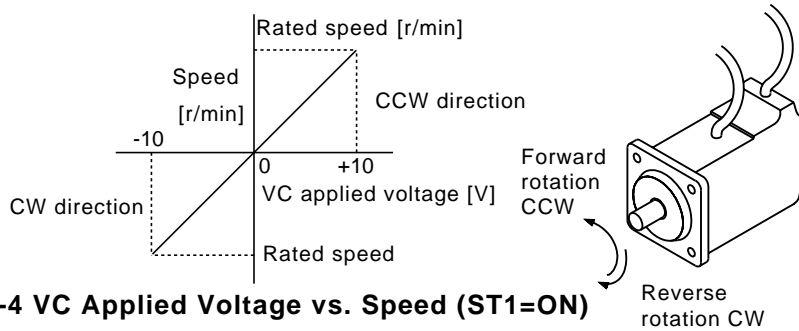
### 3.WIRING

(2) Speed control mode1

1) Speed setting

a. Speed command and speed

The servo motor is run at the speeds set in parameters No. 8 to 10 (internal speed commands 1 to 3) or at the speed set in the applied voltage of the analog speed command (VC). A relationship between the analog speed command (VC) applied voltage and the servo motor speed is shown in Fig. 3-4. The rotation directions determined by the forward rotation start signal (ST1) and reverse rotation start signal (ST2) are indicated in Table 3-2.



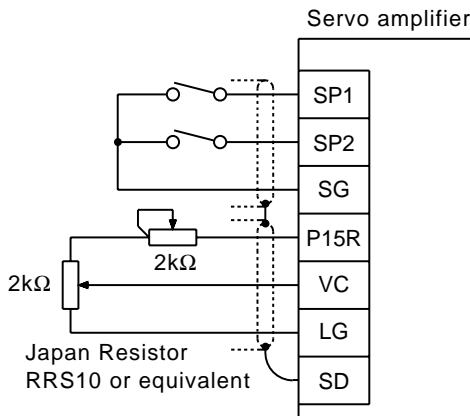
**Fig. 3-4 VC Applied Voltage vs. Speed (ST1=ON)**

**Table 3-2 ST1/ST2 and Rotation Directions**

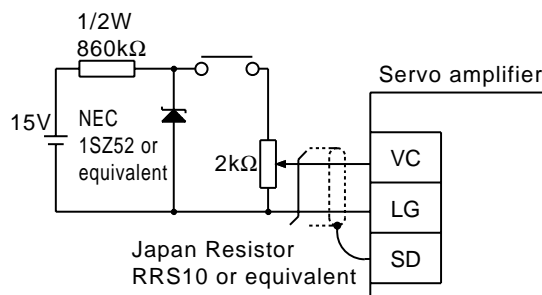
Across ST1-SG	Across ST2-SG	Rotation Direction				Internal speed commands 1 to 3
		Analog speed command (VC)				
		+ polarity	0V	- polarity		
Open	Open	Stop (Servo lock)	Stop (Servo lock)	Stop (Servo lock)	Stop (Servo lock)	
Short	Open	CCW	Stop (No servo lock)	CW	CCW	
Open	Short	CW		CCW	CW	
Short	Short	Stop (Servo lock)	Stop (Servo lock)	Stop (Servo lock)	Stop (Servo lock)	

b. Connection diagram

Generally connect as shown in Fig. 3-5. When a precision speed command is required, connect as shown in Fig. 3-6. In this case, the temperature fluctuation of the command voltage is  $\pm 0.002\%/^{\circ}\text{C}$ . Note that as the maximum value of the command voltage is approx. +6V, adjust the maximum value with parameter No. 25.



**Fig. 3-5 Connection Example 1**



**Fig. 3-6 Connection Example 2**

## 3.WIRING

- c. Speed selection 1 (SP1)/speed selection 2 (SP2) and speed command values  
 Use speed selection 1 (SP1) and speed selection 2 (SP2) to select the speed from among those set to the internal speed commands 1 to 3 and set to the analog speed command (VC) as indicated in Table 3-3.

When the speed is changed during rotation, it is increased or decreased according to the value set in parameter No. 11 or 12.

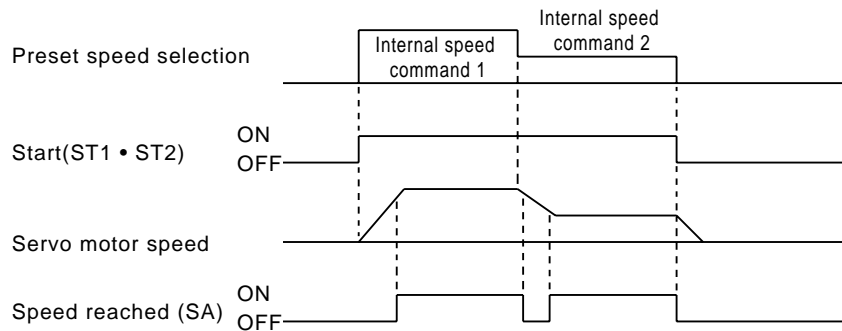
When the internal speed commands 1 to 3 are used to command the speed, the speed does not vary with the ambient temperature.

**Table 3-3 SP1/SP2 and Speed Command Values**

Across SP1-SG	Across SP2-SG	Speed Command Value
Open	Open	Analog speed command (VC)
Short	Open	Internal speed command 1 (parameter No. 8)
Open	Short	Internal speed command 2 (parameter No. 9)
Short	Short	Internal speed command 3 (parameter No. 10)

### 2) Speed reached (SA)

SA-SG are connected when the servo motor speed has nearly reached the speed set to any of the internal speed commands 1 to 3 or to the analog speed command.



### 3) Torque limit

Same as in 1), (1) in this section. To use the analog torque limit (TLA), set any of parameters No. 43 to 48 to make the torque limit (TL) available.

### 3. WIRING

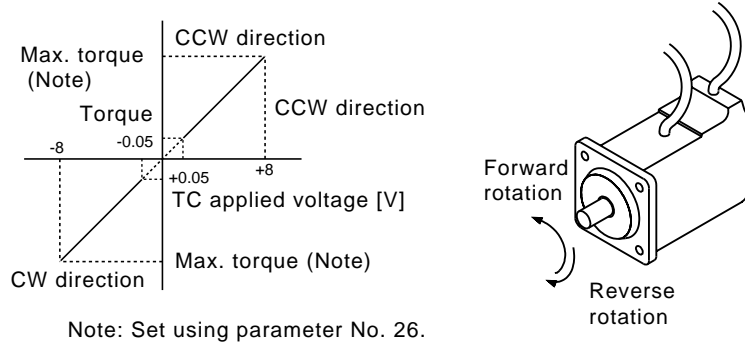
#### (3) Torque control mode

##### 1) Torque control

##### a. Torque command and generated torque

A relationship between the applied voltage of the analog torque command (TC) and the torque generated by the servo motor is shown in Fig. 3-7. Generated torque limit values will vary about 5% relative to the voltage depending on products.

Generated torque may vary at the voltage of -0.05V to +0.05V. Table 3-4 shows the torque generation directions determined by the forward rotation selection (RS1) and reverse rotation selection (RS2) when the analog torque command (TC) is used.



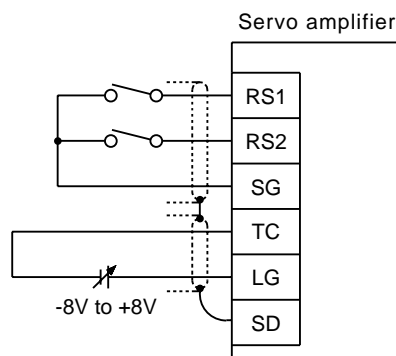
**Fig. 3-7 Torque Control Level (RS1=ON)**

**Table 3-4 Torque Generation Directions**

Across RS1-SG	Across RS2-SG	Rotation Direction		
		Analog torque command (TC)		
		+ polarity	0V	- polarity
Open	Open	No torque	No torque	No torque
Short	Open	CCW (forward rotation in driving mode/ reverse rotation in regenerative mode)		CW (reverse rotation in driving mode/ forward rotation in regenerative mode)
Open	Short	CW (reverse rotation in driving mode/ forward rotation in regenerative mode)		CCW (forward rotation in driving mode/ reverse rotation in regenerative mode)
Short	Short	No torque		No torque

##### b. Connection diagram

Connect as shown in Fig. 3-8.

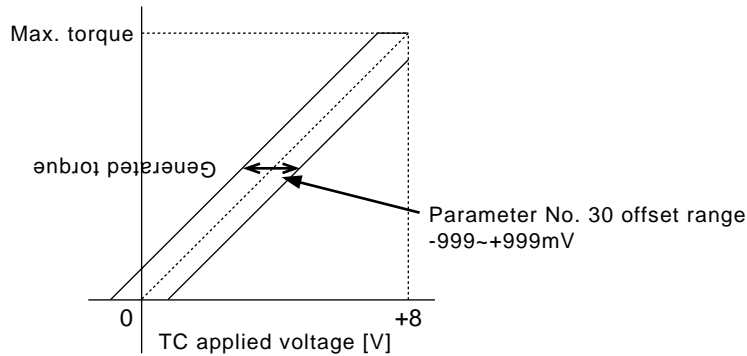


**Fig. 3-8 Connection Example**

### 3.WIRING

c. Analog torque command offset

Using parameter No. 30, the offset voltage of -999 to 999mV can be added to the TC applied voltage as shown in Fig. 3-9.



**Fig. 3-9 Analog Torque Command Offset Range**

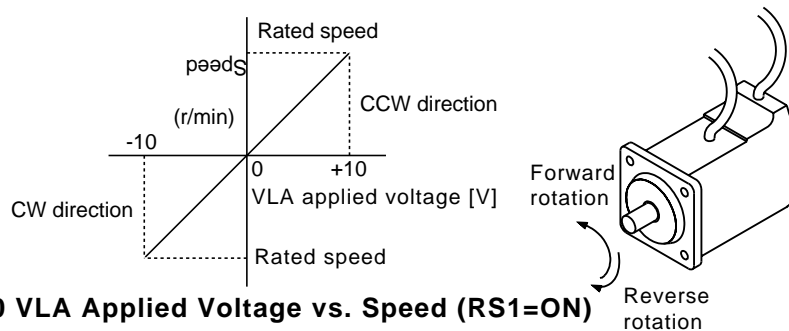
2) Torque limit

By setting parameter No. 28 (internal torque limit 1), torque is always limited to the maximum value during operation. A relationship between limit value and servo motor-generated torque is as in 1), (1) in this section. Note that the analog torque limit (TLA) is unavailable.

3) Speed limit

a. Speed limit value and speed

The speed is limited to the values set in parameters No. 8 to 10 (internal speed limits 1 to 3) or the value set in the applied voltage of the analog speed limit (VLA). A relationship between the analog speed limit (VLA) applied voltage and the servo motor speed is shown in Fig. 3-10. The limit directions determined by the forward rotation selection (RS1) and reverse rotation selection (RS2) are indicated in Table 3-5.



**Fig. 3-10 VLA Applied Voltage vs. Speed (RS1=ON)**

**Table 3-5 RS1/RS2 and Speed Limit Directions**

Across RS1-SG	Across RS2-SG	Speed Limit Direction		
		Analog speed limit (VLA)		Internal speed commands 1 to 3
		+ polarity	- polarity	
Short	Open	CCW	CW	CCW
Open	Short	CW	CCW	CW

### 3. WIRING

b. Connection diagram

Generally connect as shown in Fig. 3-11. When a precision speed command is required, connect as shown in Fig. 3-12. In this case, the temperature fluctuation of the command voltage is  $\pm 0.002\%/^{\circ}\text{C}$ . Note that as the maximum value of the command voltage is approx. +6V, adjust the maximum value using parameter No. 25.

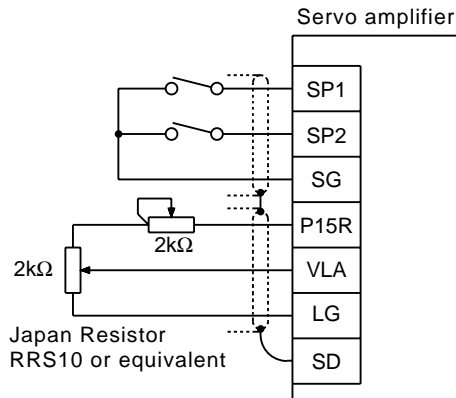


Fig. 3-11 Connection Example 1

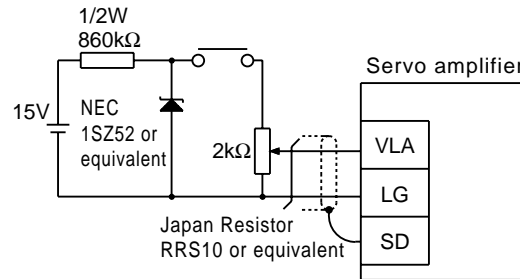


Fig. 3-12 Connection Example 2

c. Speed selection 1 (SP1)/speed selection 2 (SP2) and speed command values

Use speed selection 1 (SP1) and speed selection 2 (SP2) to select the speed from among those set to the internal speed commands 1 to 3 and set to the analog speed limit (VLA) as indicated in Table 3-6.

When the internal speed commands 1 to 3 are used to command the speed, the speed does not vary with the ambient temperature.

Table 3-6 SP1/SP2 and Speed Command Values

Across SP1-SG	Across SP2-SG	Speed Command Value
Open	Open	Analog speed limit (VLA)
Short	Open	Internal speed limit 1 (parameter No. 8)
Open	Short	Internal speed limit 2 (parameter No. 9)
Short	Short	Internal speed limit 3 (parameter No. 10)

d. Limiting speed (VLC)

VLC-SG are connected when the servo motor speed reaches the limit speed set to any of the internal speed limits 1 to 3 or analog speed limit.

### 3.WIRING

(4) Position/speed control change mode

Set □□□1 in parameter No. 0 to switch to the position/speed control change mode. This function is not available in the absolute position detection system.

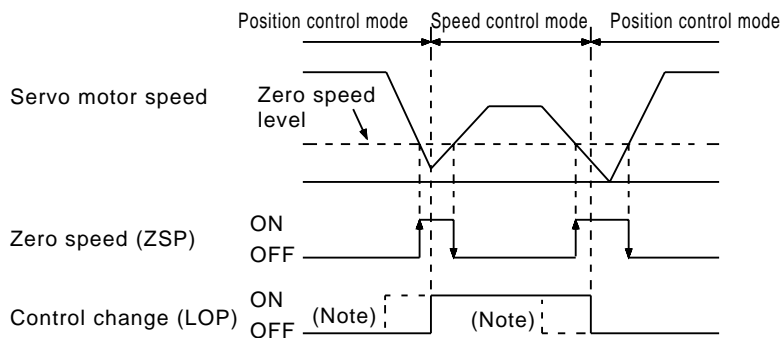
1) Control change (LOP)

Use control change (LOP) to switch between the position control mode and the speed control mode from an external contact. Relationships between LOP-SG status and control modes are indicated in Table 3-7.

**Table 3-7 Control Selection**

Across LOP-SG	Servo Control Mode
Open	Position control mode
Short	Speed control mode

The control mode may be changed in the zero-speed status. Before changing control to the other mode, make sure that the zero speed signal (ZSP) is on. To ensure safety, change control after the servo motor has stopped. When position control is changed to speed control, droop pulses are reset. If the signal has been switched on-off at the speed higher than the zero speed and the speed is then reduced to the zero speed or less, the control mode cannot be changed. A change timing chart is shown in Fig. 3-13.



Note: When ZSP is not on, control cannot be changed if LOP is switched on-off. If ZSP switches on after that, control cannot not be changed.

**Fig. 3-13 P/S Change Timing Chart**

2) Torque limit in position control mode

As in 1), (1) in this section.

### 3. WIRING

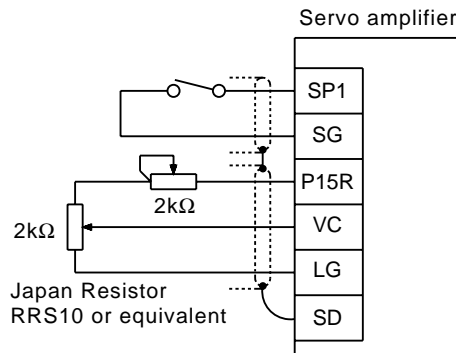
#### 3) Speed setting in speed control mode

##### a. Speed command and speed

The servo motor is run at the speed set in parameter No. 8 (internal speed command 1) or at the speed set in the applied voltage of the analog speed command (VC). A relationship between analog speed command (VC) applied voltage and servo motor speed and the rotation directions determined by the forward rotation start signal (ST1) and reverse rotation start signal (ST2) are as in 1)a, (2) in this section.

##### b. Connection diagram

Generally connect as shown in Fig. 3-14. When a precision speed command is required, refer to 1)b, (2) in this section.



**Fig. 3-14 Connection Example**

##### c. Speed selection 1 (SP1) and speed command value

Use speed selection 1 (SP1) to select between the speed set to the internal speed command 1 and the speed set to the analog speed command (VC) as indicated in Table 3-8. When the speed is changed during rotation, it is increased or decreased according to the value set in parameter No. 11 or 12.

When the internal speed command 1 is used to command the speed, the speed does not vary with the ambient temperature.

**Table 3-8 SP1 and Speed Command Value**

Across SP1-SG	Speed Command Value
Open	Analog speed command (VC)
Short	Internal speed command 1 (parameter No. 8)

##### d. Speed reached (SA)

As in 2), (2) in this section.

#### 4) Torque limit in torque control mode

As in 2), (3) in this section.



### 3.WIRING

(5) Speed/torque control change mode

Set  $\square\square\square 3$  in parameter No. 0 to switch to the speed/torque control change mode.

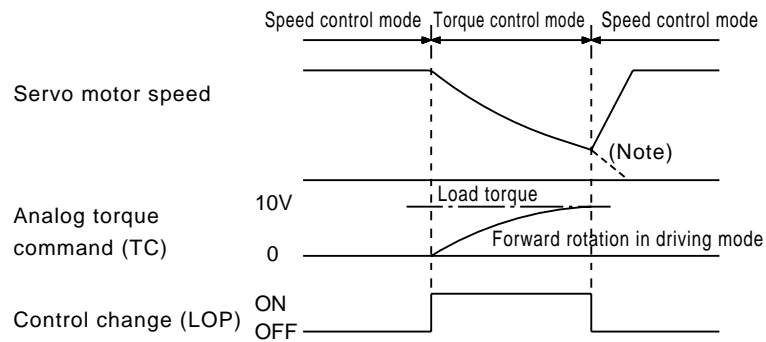
1) Control change (LOP)

Use control change (LOP) to switch between the speed control mode and the torque control mode from an external contact. Relationships between LOP-SG status and control modes are indicated in Table 3-9.

**Table 3-9 Control Selection**

Across LOP-SG	Servo Control Mode
Open	Speed control mode
Short	Torque control mode

The control mode may be changed at any time. A change timing chart is shown in Fig. 3-15.



Note: When the start signal (ST1/ST2) is switched off as soon as the mode is changed to speed control, the servo motor comes to a stop according to the deceleration time constant.

**Fig. 3-15 S/T Change Timing Chart**

2) Speed setting in speed control mode

As in 1)a, (2) in this section.

3) Torque limit in speed control mode

As in 1), (1) in this section.

### 3. WIRING

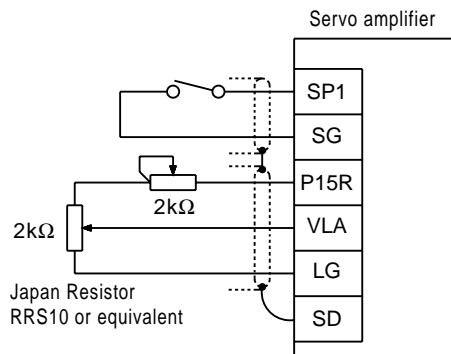
#### 4) Speed limit in torque control mode

##### a. Speed limit value and speed

The speed is limited to the limit value set in parameter No. 8 (internal speed limit 1) or the value set in the applied voltage of the analog speed limit (VLA). A relationship between the analog speed limit (VLA) applied voltage and the servo motor speed is as in 3)a, (3) in this section.

##### b. Connection diagram

Generally connect as shown in Fig. 3-16. When a precision speed command is required, refer to 3b, (3) in this section.



**Fig. 3-16 Connection Example**

##### c. Speed selection 1 (SP1) and speed limit value

Use speed selection 1 (SP1) to select between the speed set to the internal speed limit 1 and the speed set to the analog speed limit (VLA) as indicated in Table 3-10.

When the internal speed limit 1 is used to command the speed, the speed does not vary with the ambient temperature.

**Table 3-10 SP1 and Speed Limit Value**

Across SP1-SG	Speed Command Value
Open	Analog speed limit (VLA)
Short	Internal speed limit 1 (parameter No. 8)

##### d. Limiting speed (VLC)

As in 3)d, (3) in this section.

#### 5) Torque control in torque control mode

As in 1), (3) in this section.

#### 6) Torque limit in torque control mode

As in 2), (3) in this section.

### 3.WIRING

(6) Torque/position control change mode

Set □□□5 in parameter No. 0 to switch to the torque/position control change mode. This function is not available for the absolute position detection system.

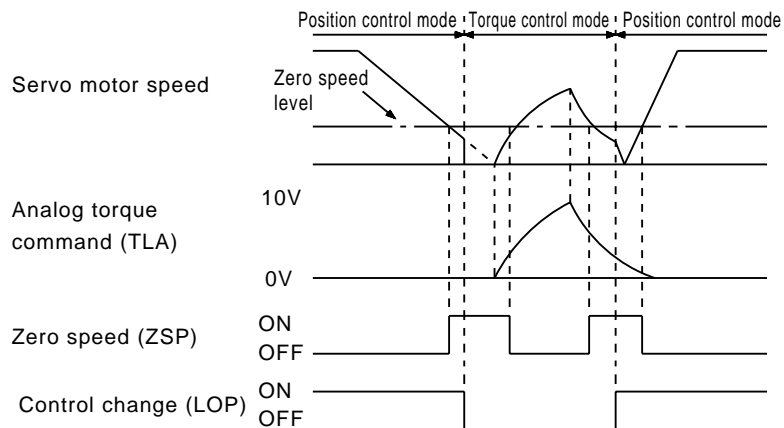
1) Control change (LOP)

Use control change (LOP) to switch between the torque control mode and the position control mode from an external contact. Relationships between LOP-SG status and control modes are indicated in Table 3-11.

**Table 3-11 Control Selection**

Across LOP-SG	Servo Control Mode
Open	Torque control mode
Short	Position control mode

The control mode may be changed in the zero-speed status. Before changing control to the other mode, make sure that the zero speed signal (ZSP) is on. To ensure safety, droop pulses are reset when the mode is changed after the servo motor has stopped. If the signal has been switched on-off at the speed higher than the zero speed and the speed is then reduced to the zero speed or less, the control mode cannot be changed. A change timing chart is shown in Fig. 3-17.



**Fig. 3-17 T/P Change Timing Chart**

2) Speed limit in torque control mode

As in 4), (5) in this section.

3) Torque control in torque control mode

As in 1), (3) in this section.

4) Torque limit in torque control mode

As in 2), (3) in this section.

5) Torque limit in position control mode

As in 1), (1) in this section.

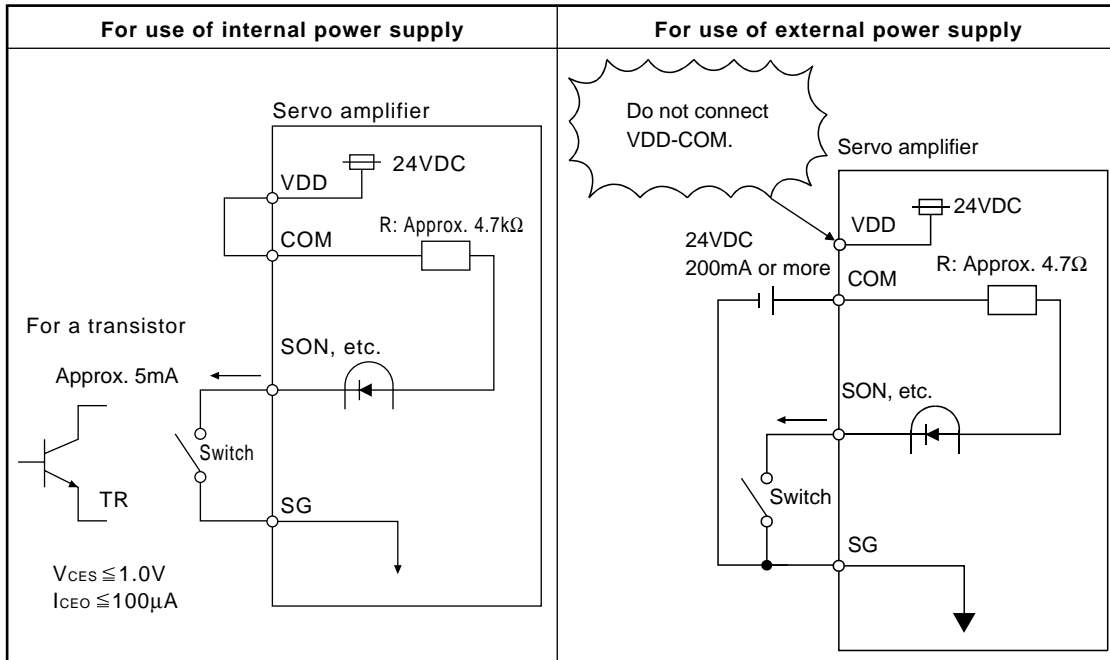
### 3.WIRING

#### 3-1-4 Interfaces

The details of the interfaces (refer to I/O Division in the table) to the signals indicated in Section 3-1-2 (4) are given below. Refer to the following and connect the interfaces with the external equipment.

##### (1) Digital input interface DI-1

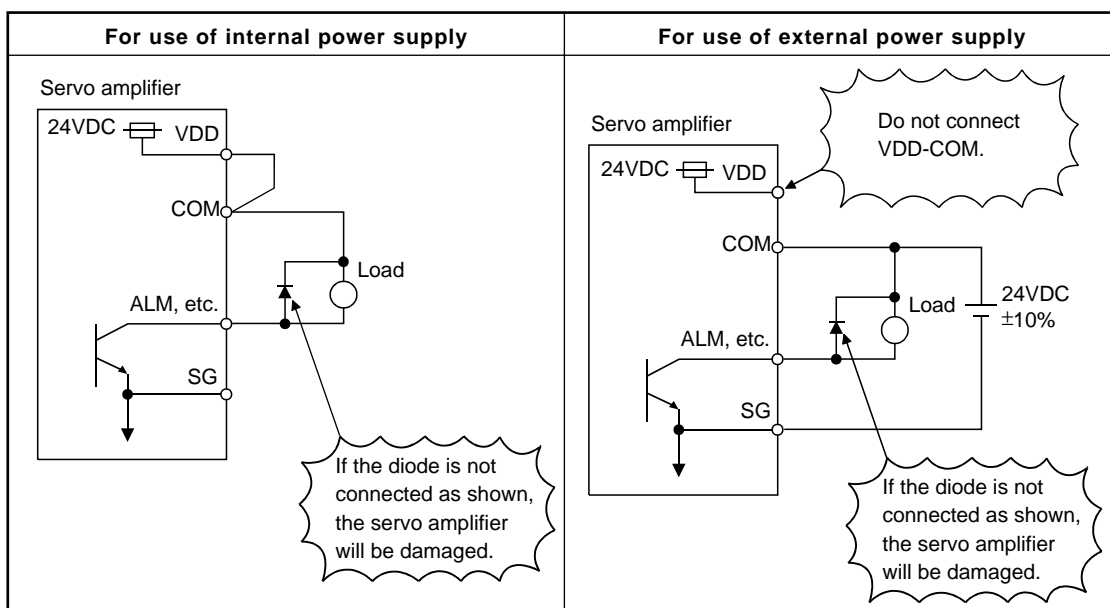
Give a signal with a relay or open collector transistor.  
Source input is also possible. Refer to (7) in this section.



##### (2) Digital output interface DO-1

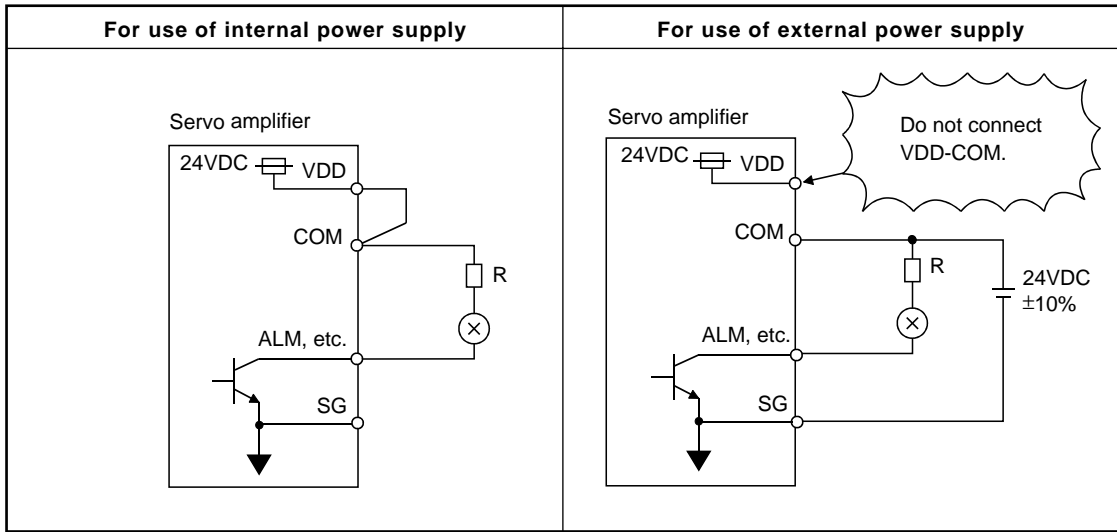
A lamp, relay or photocoupler can be driven. Provide a diode (D) for an inductive load, or an inrush current suppressing resistor (R) for a lamp load. (Permissible current: 40mA or less, inrush current: 100mA or less)

##### 1) Inductive load



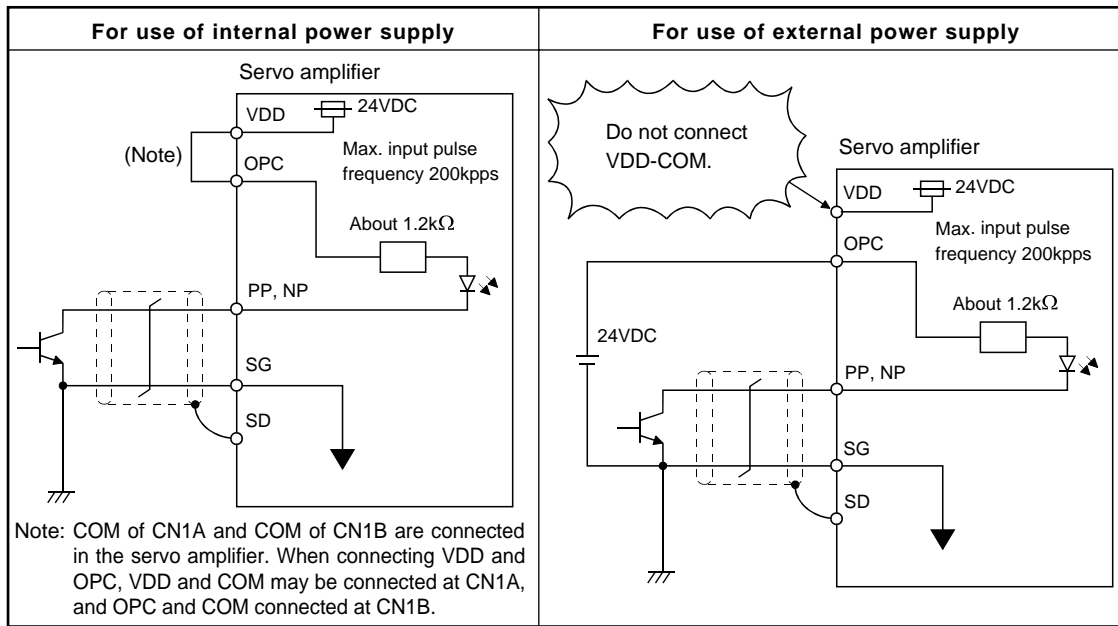
### 3.WIRING

#### 2) Lamp load

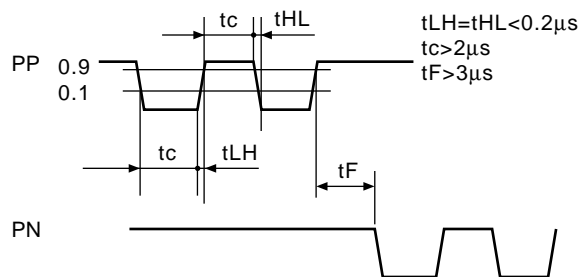


#### (3) Pulse train input interface DI-2

- 1) Open collector system
  - Interface example



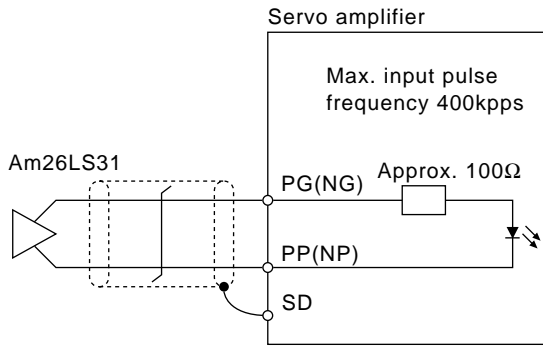
- Conditions of the input pulse



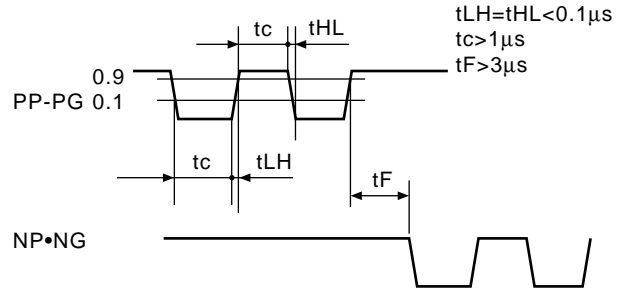
### 3.WIRING

#### 2) Differential line driver system

- Interface example



- Conditions of the input pulse

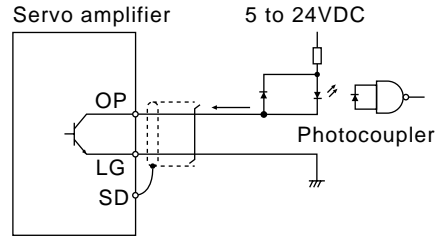
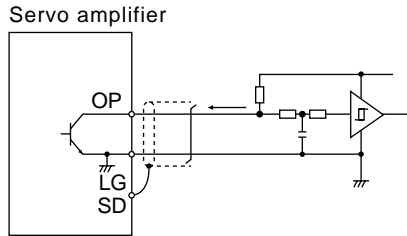


#### (4) Encoder pulse output DO-2

##### 1) Open collector system

- Interface example

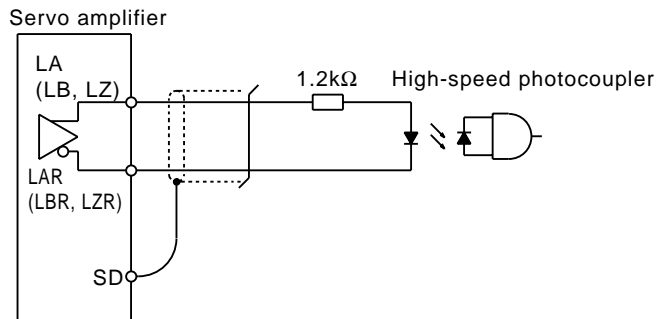
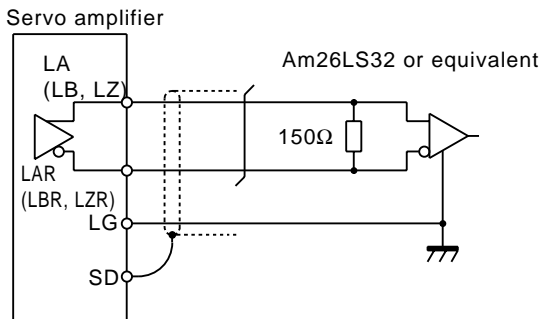
Max. output current: 35mA



##### 2) Differential line driver system

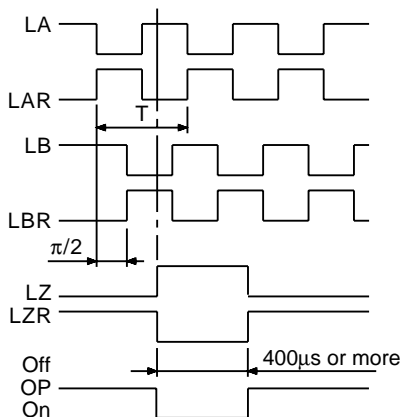
- Interface example

Max. output current: 35mA



- Output signal waveform

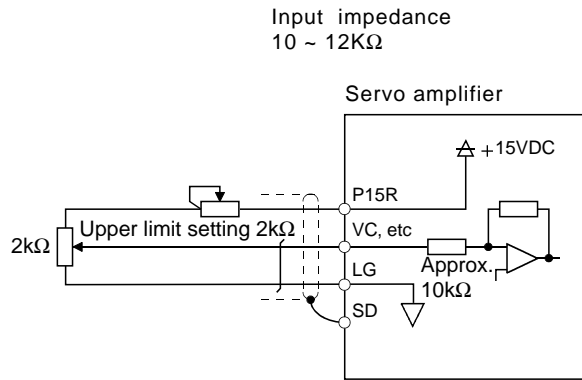
Servo motor CCW rotation



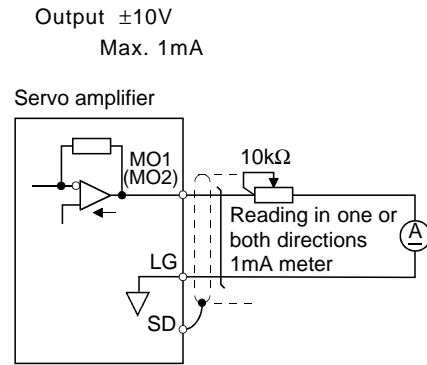
LZ signal varies  $\pm 3/8T$  on its leading edge.

### 3.WIRING

#### (5) Analog input

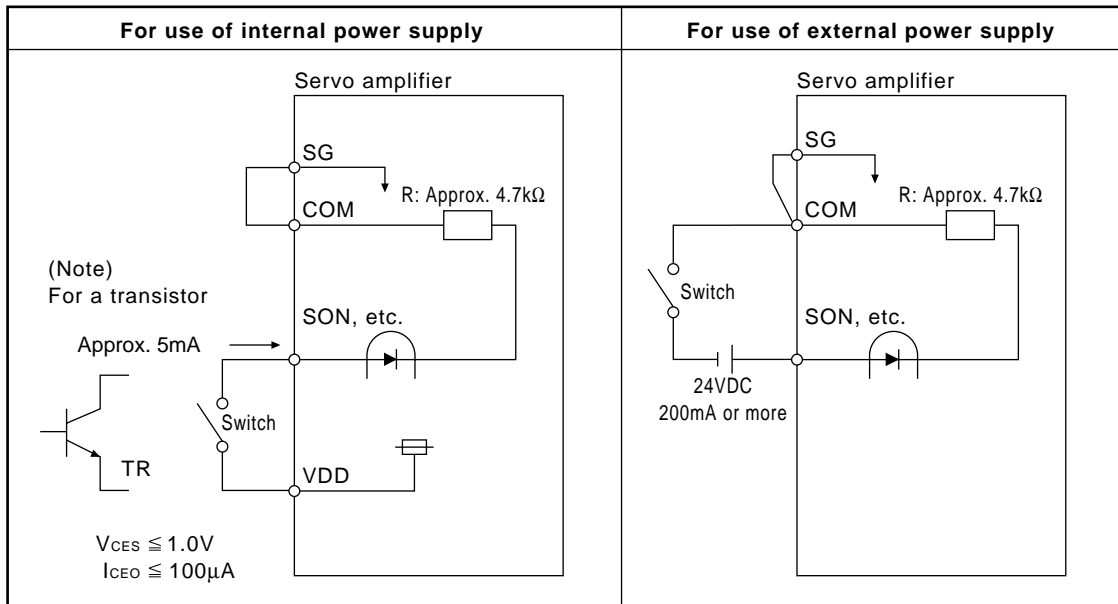


#### (6) Analog output



#### (7) Source input interface

When using the input interface of source type, all DI-1 input signals are of source type. Source output cannot be provided.



Note: This also applies to the use of the external power supply.

## 3. WIRING

### 3-2 Connection of servo amplifier and servo motor

#### 3-2-1 Connection instructions



#### WARNING

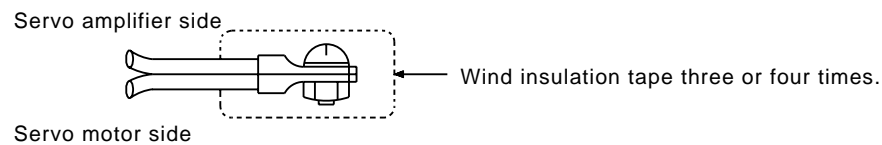
Insulate the connections of the power supply terminals to prevent an electric shock.



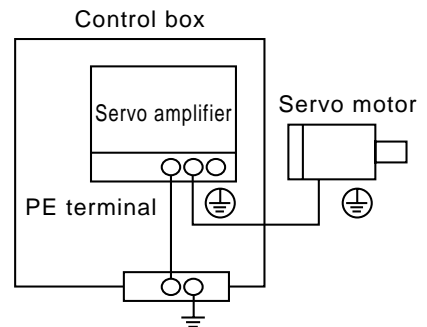
#### CAUTION

1. Connect the wires to the correct phase terminals (U, V, W) of the servo amplifier and servo motor. Otherwise, the servo motor will operate improperly.
2. Do not connect AC power supply directly to the servo motor. Otherwise, a fault may occur.

- (1) Wind an insulation tape around the connection several times. For the EN Standard-compliant model, connect via a fixed terminal block.



- (2) For grounding, connect the earth cable of the servo motor to the protective earth (PE) terminal of the servo amplifier and connect the ground cable of the servo amplifier to the earth via the protective earth of the control box. Do not connect them directly to the protective earth of the control panel.
- (3) Do not share the 24VDC power supply between the interface and electromagnetic brake. Always use the power supply designed exclusively for the electromagnetic brake.





# 3.WIRING

## 3-2-2 Connection diagram

The following table lists wiring methods according to the servo motor types. Use the connection diagram which conforms to the servo motor used. For cables required for wiring, refer to Section 6-2-1.

For encoder cable connection, refer to Section 6-1-2.

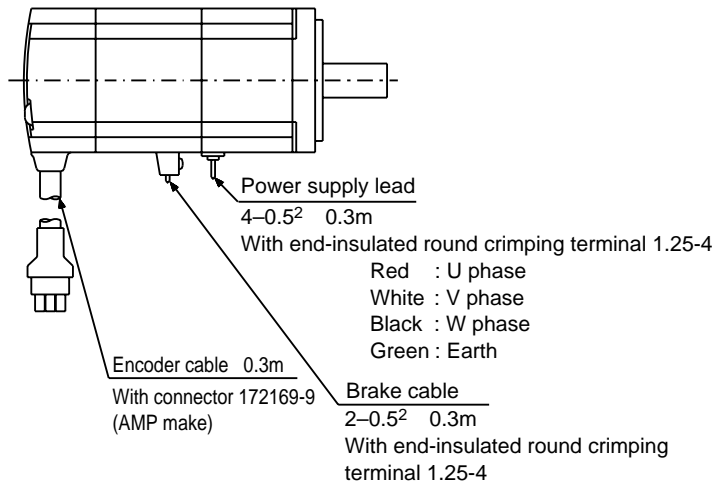
For the connectors of the servo motor, refer to Chapter 3 of the servo motor instruction manual.

Servo Motor	Connection Diagram
HC-MF053 (B) (-UE) to 73 (B) (-UE) HA-FF053 (B) to 63 (B) HC-UF13 (B) to 73 (B)	<p>Note: 1. To prevent an electric shock, always connect the protective earth (PE) terminal of the servo amplifier to the protective earth (PE) of the control box.</p> <p>2. This circuit applies to the servo motor with electromagnetic brake.</p> <p>3. For the HA-FF series, connect the ground cable to the earth terminal of the servo motor.</p>
HA-FF053 (B)-UE to 63 (B)-UE HC-SF121 (B) to 301 (B) HC-SF202 (B) • 352 (B) HC-SF203 (B) • 353 (B) HC-UF202 (B)	<p>Note: 1. To prevent an electric shock, always connect the protective earth (PE) terminal of the servo amplifier to the protective earth (PE) of the control box.</p> <p>2. This circuit applies to the servo motor with electromagnetic brake.</p>
HC-SF81 (B) HC-SF52 (B) to 152 (B) HC-SF53 (B) to 153 (B) HC-RF103 (B) to 203 (B) HC-UF72 (B) • 152 (B)	<p>Note: 1. To prevent an electric shock, always connect the protective earth (PE) terminal of the servo amplifier to the protective earth (PE) of the control box.</p> <p>2. This circuit applies to the servo motor with electromagnetic brake.</p>

# 3.WIRING

## 3-2-3 I/O terminals

### (1) HC-MF(-UE) series

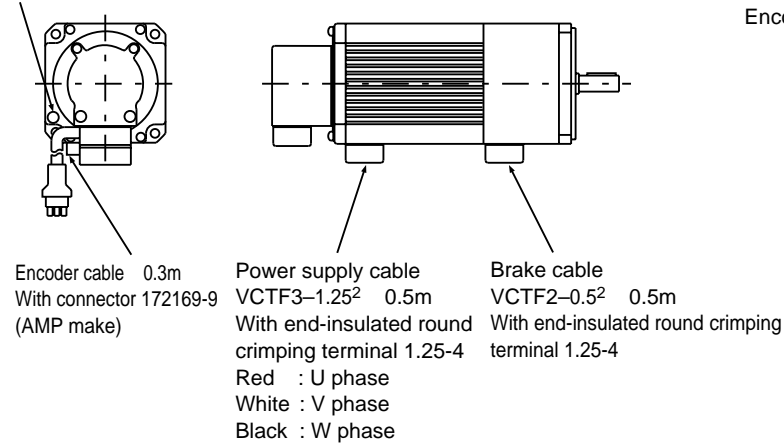


Encoder connector signal arrangement

1	2	3
MR	MRR	BAT
4	5	6
MD	MDR	
7	8	9
P5	LG	SHD

### (2) HA-FF series

Earth terminal, M3 screw

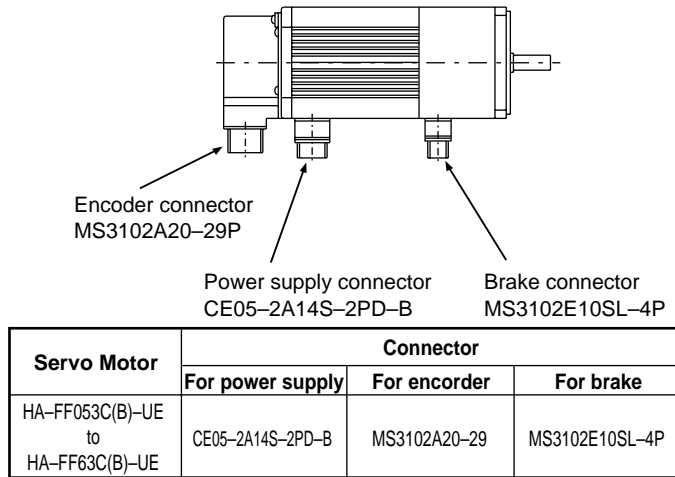


Encoder connector signal arrangement

1	2	3
MR	MRR	BAT
4	5	6
MD	MDR	
7	8	9
P5	LG	SHD

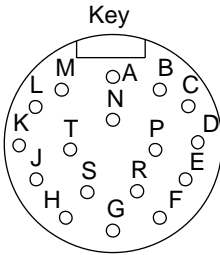
### 3.WIRING

#### (3) HA-FFC-UE series



Encoder connector signal arrangement

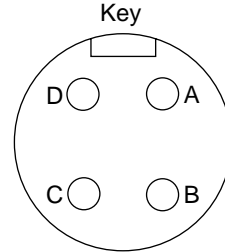
MS3102A20-29P



Pin	Signal
A	MD
B	MDR
C	MR
D	MRR
E	
F	BAT
G	LG
H	
J	

Pin	Signal
K	
L	
M	
N	SHD
P	
R	LG
S	P5
T	

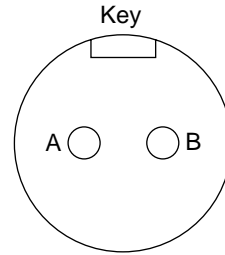
Power supply connector signal arrangement CE05-2A14S-2PD-B



Pin	Signal
A	U
B	V
C	W
D	⊕ (Earth)

Brake connector signal arrangement

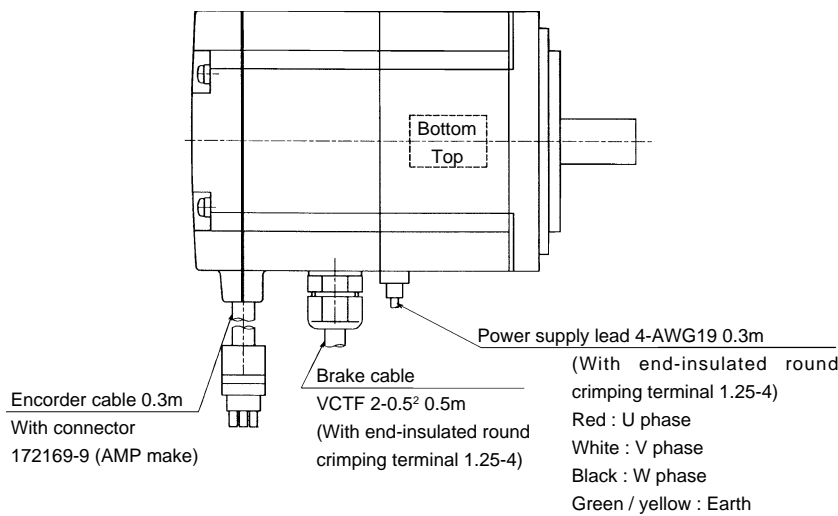
MS3102A10SL-4P



Pin	Signal
A	(Note) B1
B	(Note) B2

Note: 24VDC without polarity.

#### (4) HC-UF 3000r/min series

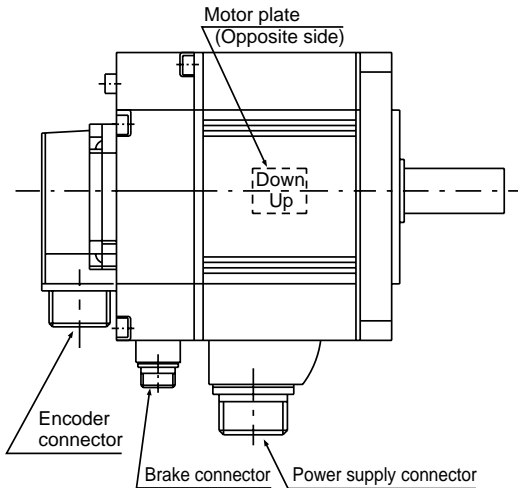


Encoder connector signal arrangement

1	2	3
MR	MRR	BAT
4	5	6
MD	MDR	
7	8	9
P5	LG	SHD

### 3.WIRING

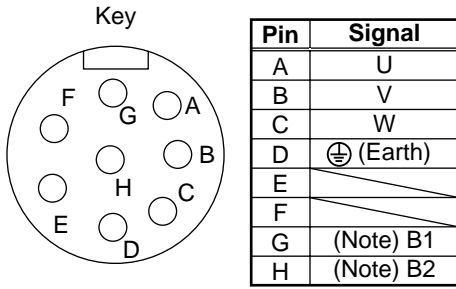
#### (5) HC-SF/HC-RF•HC-UF 2000r/min series



Servo Motor	Servo Motor Side Connectors		
	For power supply	For encoder	Electromagnetic Brake Connector
HC-SF81(B) HC-SF52(B) to 152(B) HC-SF53(B) to 153(B)	CE05-2A22-23PD-B	MS3102A20-29P	The connector for power is shared.
HC-SF121(B) to 301(B) HC-SF202(B) • 352(B) HC-SF203(B) • 353(B)	CE05-2A24-10PD-B		MS3102A10SL-4P
HC-RF103(B) to 203(B)	CE05-2A22-23PD-B	MS3102A20-29P	The connector for power is shared.
HC-UF72(B) • 152(B)	CE05-2A22-23PD-B	MS3102A20-29P	The connector for power is shared.
HC-UF202(B)	CE05-2A24-10PD-B		MS3102A10SL-4P

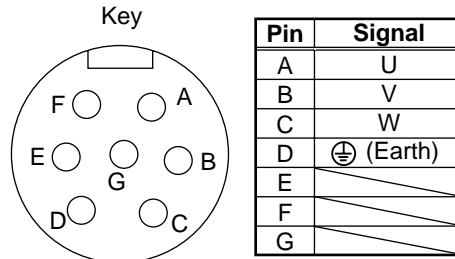
#### Power supply connector signal arrangement

CE05-2A22-23PD-B



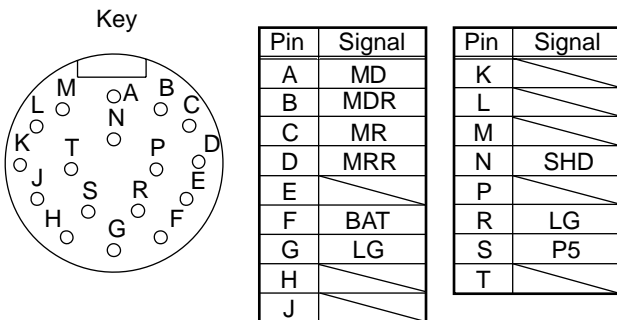
Note: 24VDC without polarity

CE05-2A24-10PD-B



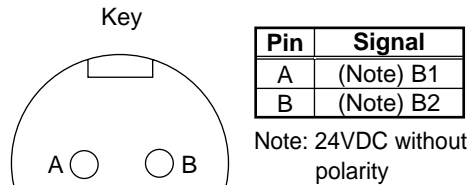
#### Encoder connector signal arrangement

MS3102A20-29P



#### Electromagnetic brake connector signal pin-outs

MS3102A10SL-4P



### 3.WIRING

#### 3-2-4 Connectors used for servo motor wiring

The connector make-ups classified by the operating environment are given below. Use the models of the manufactures given or equivalent.

(1) HC-MF(-UE) • HA-FF • HC-UF3000r/min series

Use round crimping terminals (1.25-4) for connection of the power supply and electromagnetic brake. The encoder connector used should be the connector indicated in this section or equivalent. This connector may be used for the EN Standard/UL/C-UL Standard but is not waterproof.

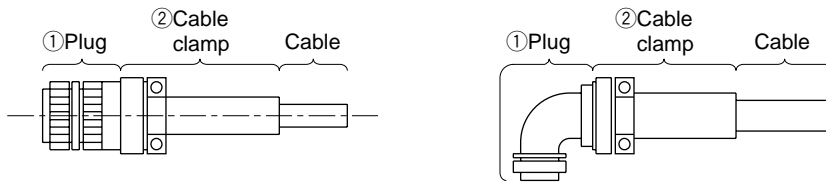
Servo Motor	Servo Motor Side Connector(AMP)	Encode Cable Connector		
		Housing (AMP)	Connector pins (AMP)	Cable clamp (Toa Denki Kogyo)
HC-MF□(B) HC-MF□(B)-UE HA-FF□(B) HC-UF13 to 73(B)	172169-9	1-172161-9	170363-1	MTI-0002

(2) HA-FFC-UE series

Use of the waterproof connector would not improve the degree of ingress protection (IP54) of the HA-FF□C(B)-UE.

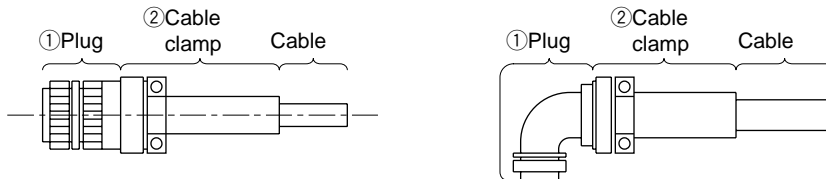
1) Non-waterproof/UL/C-UL Standard-compliant

- a. When using cable type cables
  - For power supply connection



Servo Motor	Servo Motor Side Connector	① Plug (Daiichi Denshi Kogyo)		② Cable clamp (Daiichi Denshi Kogyo)
		Type	Model	
HA-FF□C(B)-UE	CE05-2A14S-2PD-B	Straight	MS3106B14S-2S	MS3057-6A
		Angle	MS3108B14S-2S	

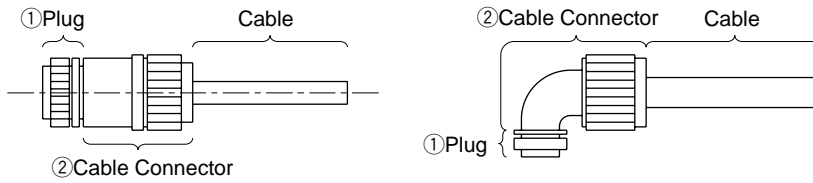
- For encoder connection



Servo Motor	Servo Motor Side Connector	① Plug (Daiichi Denshi Kogyo)		② Cable clamp (Daiichi Denshi Kogyo)
		Type	Model	
HA-FF□C(B)-UE	MS3102A20-29P	Straight	MS3106B20-29S	MS3057-12A
		Angle	MS3108B20-29S	

### 3. WIRING

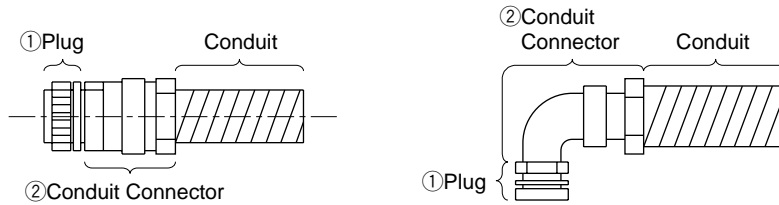
- For brake connection



Servo Motor	Servo Motor Side Connector	① Plug (Daiichi Denshi Kogyo)	② Cable connector			
			Type	Maker	Cable OD	Model
HA-FF□C(B)-UE	MS3102A10SL-4P	MS3106A10SL-4S(D190)	Straight	Nippon Flex	4 to 8	ACS-08RL-MS10F
					8 to 12	ACS-12RL-MS10F
				Daiwa Dengyo	5 to 8.3	YS010-5 to 8
			Angle	Nippon Flex	4 to 8	ACA-08RL-MS10F
					8 to 12	ACA-12RL-MS10F
				Daiwa Dengyo	5 to 8.3	YL010-5 to 8

- a. When using flexible conduits

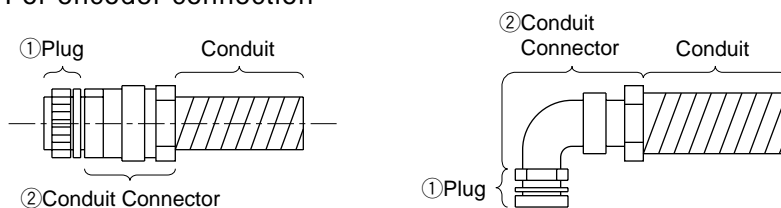
- For power supply connection



Servo Motor	Servo Motor Side Connector	① Plug (Daiichi Denshi Kogyo)	② Conduit Connector				Conduit	
			Type	Maker	Size	Model	Model	ID
HA-FF□C(B)-UE	CE05-2A14S-2PD-B	MS3106A14S-2S(D190)	Straight	Nippon Flex	1/4	RCC-102RL-MS14F	VF-02	8.3
					3/8	RCC-103RL-MS14F	VF-03	10.6
					1/2	RCC-104RL-MS14F	VF-04	14.0
				Daiwa Dengyo	10	MSA-10-14	FCV10	10.0
					12	MSA-12-14	FCV12	12.3
					1/4	RCC-302RL-MS14F	VF-02	8.3
			Angle	Nippon Flex	3/8	RCC-303RL-MS14F	VF-03	10.6
					1/2	RCC-304RL-MS14F	VF-04	14.0
					10	MAA-10-14	FCV10	10.0
				Daiwa Dengyo	12	MAA-12-14	FCV12	12.3

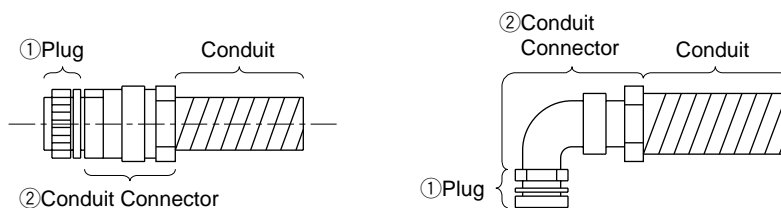
### 3.WIRING

- For encoder connection



Servo Motor	Servo Motor Side Connector	① Plug (Daiichi Denshi Kogyo)	② Conduit Connector				Conduit	
			Type	Maker	Size	Model	Model	ID
HA-FF□C(B)-UE	MS3102A20-29P	MS3106A20-29S(D190)	Straight	Nippon Flex	1/2	RCC-104RL-MS20F	VF-04	14.0
					3/4	RCC-106RL-MS20F	VF-06	19.0
				Daiwa Dengyo	16	MSA-16-20	FCV16	15.8
					22	MSA-22-20	FCV22	20.8
			Angle	Nippon Flex	1/2	RCC-304RL-MS20F	VF-04	14.0
					3/4	RCC-306RL-MS20F	VF-06	19.0
Daiwa Dengyo	16	MAA-16-20	FCV16	15.8				
	22	MAA-22-20	FCV22	20.3				

- For brake connection



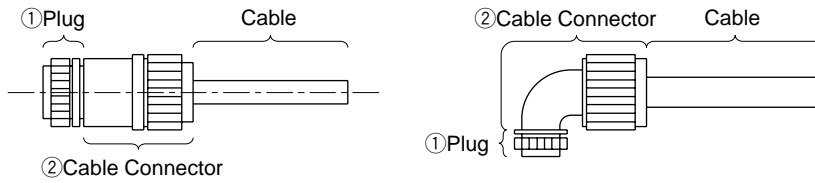
Servo Motor	Servo Motor Side Connector	① Plug (Daiichi Denshi Kogyo)	② Conduit Connector				Conduit	
			Type	Maker	Size	Model	Model	ID
HA-FF□C(B)-UE	MS3102A10SL-4P	MS3106A10SL-4S(D190)	Straight	Nippon Flex	1/4	RCC-102RL-MS10F	VF-02	8.3
				Daiwa Dengyo	10	MSA-10-10	FCV10	10.0
			Angle	Nippon Flex	1/4	RCC-302RL-MS10F	VF-02	8.3
				Daiwa Dengyo	10	MAA-10-10	FCV10	10.0

### 3. WIRING

#### 2) EN Standard/UL/C-UL Standard-compliant

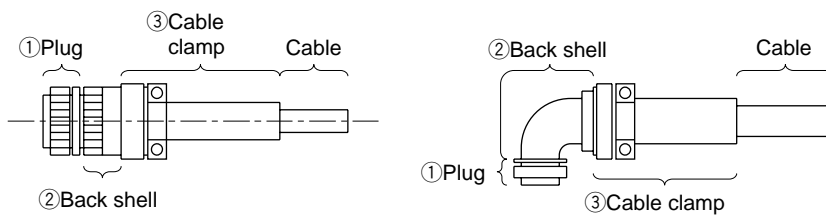
##### a. When using cabtyre cables

- For power supply connection



Servo Motor	Servo Motor Side Connector	① Plug (Daiichi Denshi Kogyo)	② Cable connector			
			Maker	Type	Cable OD	Model
HA-FF□C(B)-UE	CE05-2A14S-2PD-B	CE05-6A14S-2SD-B	Nippon Flex	Straight	4 to 8	ACS-08RL-MS14F
					8 to 12	ACS-12RL-MS14F
				Angle	4 to 8	ACA-08RL-MS14F
					8 to 12	ACA-12RL-MS14F
			Daiwa Dengyo	Straight	5 to 8.3	YS014-5 to 8
					8.3 to 11.3	YS014-9 to 11
Angle	5 to 8.3	YL014-5 to 8				
	8.3 to 11.3	YS014-9 to 11				

- For encoder connection

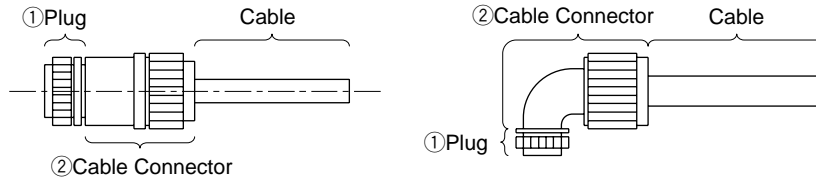


Servo Motor	Servo Motor Side Connector	① Plug (Daiichi Denshi Kogyo)	② Back shell (Daiichi Denshi Kogyo)		② Cable clamp (Daiichi Denshi Kogyo)	
			Type	Model	Cable OD	Model
HA-FF□C(B)-UE	MS3102A20-29P	MS3106A20-29S(D190)	Straight	CE02-20BS-S	6.8 to 10	CE3057-12A-3
			Angle	CE-20BA-S		



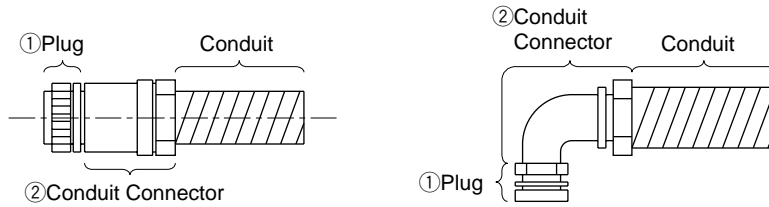
### 3.WIRING

- For brake connection



Servo Motor	Servo Motor Side Connector	① Plug (Daiichi Denshi Kogyo)	② Cable Connector			
			Type	Maker	Cable OD	Model
HA-FF□C(B)-UE	MS3102A10SL-4P	MS3106A10SL-4S(D190)	Straight	Nippon Flex	4 to 8	ACS-08RL-MS10F
					8 to 12	ACS-12RL-MS10F
				Daiwa Dengyo	5 to 8.3	YS0-10-5 to 8
			Angle	Nippon Flex	4 to 8	ACA-08RL-MS10F
					8 to 12	ACA-12RL-MS10F
				Daiwa Dengyo	5 to 8.3	YL010-5 to 8

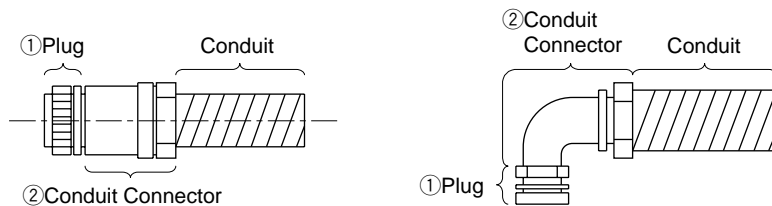
- b. When using flexible conduits
- For power supply connection



Servo Motor	Servo Motor Side Connector	① Plug (Daiichi Denshi Kogyo)	② Conduit Connector				Conduit	
			Type	Maker	Size	Model	Model	ID
HA-FF□C(B)-UE	CE05-2A14S-2PD-B	CE05-6A14S-2SD-B	Straight	Nippon Flex	1/4	RCC-102RL-MS14F	VF-02	8.3
					3/8	RCC-103RL-MS14F	VF-03	10.6
					1/2	RCC-104RL-MS14F	VF-04	14.0
				Daiwa Dengyo	10	MSA-10-14	FCV10	10.0
					12	MSA-12-14	FCV12	12.3
			Angle	Nippon Flex	1/4	RCC-302RL-MS14F	VF-02	8.3
					3/8	RCC-303RL-MS14F	VF-03	10.6
					1/2	RCC-304RL-MS14F	VF-04	14.0
				Daiwa Dengyo	10	MAA-10-14	FCV10	10.0
					12	MAA-12-14	FCV12	12.3

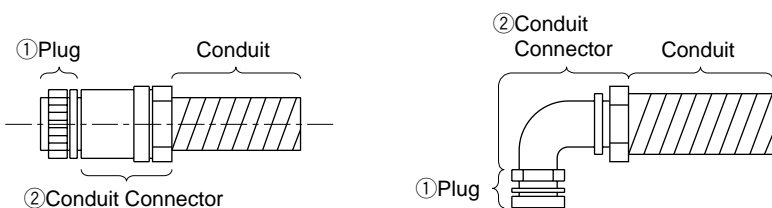
### 3.WIRING

- For encoder connection



Servo Motor	Servo Motor Side Connector	① Plug (Daiichi Denshi Kogyo)	② Conduit Connector				Conduit	
			Type	Maker	Size	Model	Model	ID
HA-FF□C(B)-UE	MS3102A20-29P	MS3106A20-29S(D190)	Straight	Nippon Flex	1/2	RCC-104RL-MS20F	VF-04	14.0
					3/4	RCC-106RL-MS20F	VF-06	19.0
				Daiwa Dengyo	16	MSA-16-20	FCV16	15.8
					22	MSA-22-20	FCV22	20.8
			Angle	Nippon Flex	1/2	RCC-304RL-MS20F	VF-04	14.0
					3/4	RCC-306RL-MS20F	VF-06	19.0
Daiwa Dengyo	16	MAA-16-20	FCV16	15.8				
	22	MAA-22-20	FCV22	20.8				

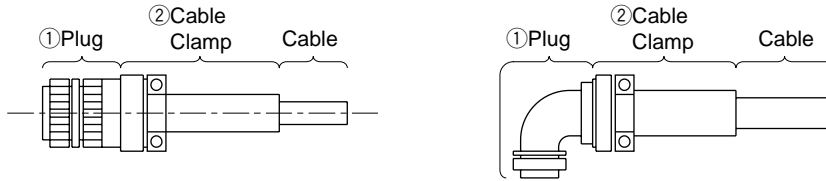
- For brake connection



Servo Motor	Servo Motor Side Connector	① Plug (Daiichi Denshi Kogyo)	② Conduit Connector				Conduit	
			Type	Maker	Size	Model	Model	ID
HA-FF□C(B)-UE	MS3102A10SL-4P	MS3106A10SL-4S(D190)	Straight	Nippon Flex	1/4	RCC-102RL-MS10F	VF-02	8.3
				Daiwa Dengyo	10	MSA-10-10	FCV10	10.0
			Angle	Nippon Flex	1/4	RCC-302RL-MS10F	VF-02	8.3
				Daiwa Dengyo	10	MAA-10-10	FCV10	10.0

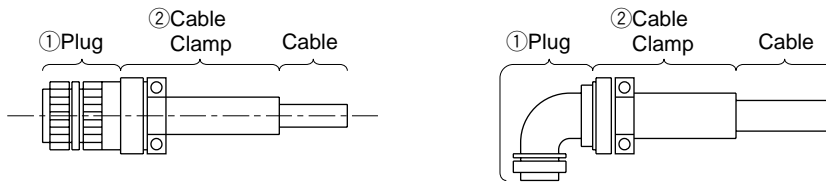
### 3.WIRING

- (3) HA-SF•HC-RF•HC-UF 2000r/min series  
 1) Non-waterproof/UL/C-UL Standard-compliant  
 a. When using cable type cables  
 • For power supply connection



Servo Motor	Servo Motor Side Connector	① Plug (Daiichi Denshi Kogyo)		② Cable clamp (Daiichi Denshi Kogyo)
		Type	Model	
HC-SF52(B) to 152(B) HC-RF103(B) to 203(B) HC-UF72(B) • 152(B)	CE05-2A22-23PD-B	Straight	MS3106B22-23S	MS3057-12A
		Angle	MS3108B22-23S	
HC-SF202(B) to 502(B) HC-RF353(B) to 503(B) HC-UF202(B) to 502(B)	CE05-2A24-10PD-B	Straight	MS3106B24-10S	MS3057-16A
		Angle	MS3108B24-10S	
HC-SF702(B)	CE05-2A32-17PD-B	Straight	MS3106B32-17S	MS3057-20A
		Angle	MS3108B32-17S	

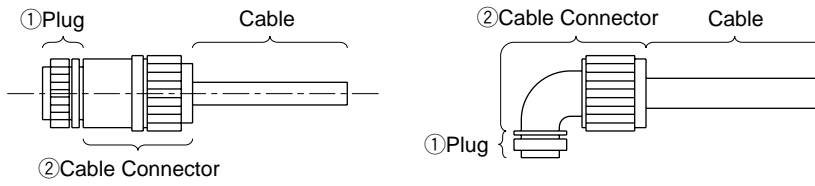
- For encoder connection



Servo Motor	Servo Motor Side Connector	① Plug (Daiichi Denshi Kogyo)		② Cable Clamp (Daiichi Denshi Kogyo)
		Type	Model	
HC-SF52(B) to 702(B) HC-RF103(B) to 503(B) HC-UF72(B) to 502(B)	MS3102A20-29P	Straight	MS3106B20-29S	MS3057-12A
		Angle	MS3108B20-29S	

### 3.WIRING

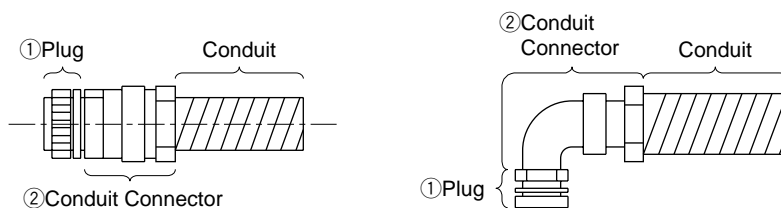
- For brake connection



Servo Motor	Servo Motor Side Connector	① Plug (Daichi Denshi Kogyo)	② Cable Connector			
			Type	Maker	Cable OD	Model
HC-SF202(B) to 702(B) HC-UF202(B) to 502(B)	MS3102A10SL-4P	MS3106A10SL-4S	Straight	Nippon Flex	4 to 8	ACS-08RL-MS10F
					8 to 12	ACS-12RL-MS10F
				Daiwa Dengyo	5 to 8.3	YS010-5 to 8
			Angle	Nippon Flex	4 to 8	ACA-08RL-MS10F
					8 to 12	ACA-12RL-MS10F
				Daiwa Dengyo	5 to 8.3	YL010-5 to 8

### 3.WIRING

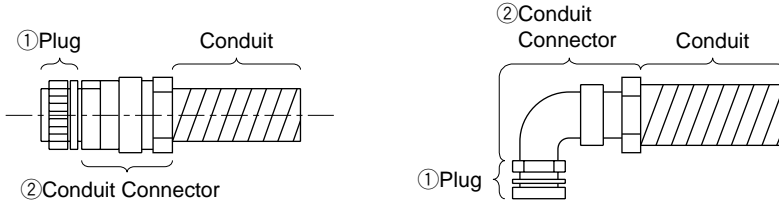
- b. When using flexible conduits  
 • For power supply connection



Servo Motor	Servo Motor Side Connector	① Plug (Daiichi Denshi Kogyo)	② Conduit Connector				Conduit	
			Type	Maker	Size	Model	Model	ID
HC-SF52(B) to 152(B) HC-RF103(B) to 203(B) HC-UF72(B) • 152(B)	CE05-2A22-23PD-B	MS3106A22-23S(D190)	Straight	Nippon Flex	1/2	RCC-104RL-MS22F	VF-04	14.0
					3/4	RCC-106RL-MS22F	VF-06	19.0
					1	RCC-108RL-MS22F	VF-08	24.4
				Daiwa Dengyo	16	MSA-16-22	FCV16	15.8
					22	MSA-22-22	FCV22	20.8
			Angle	Nippon Flex	1/2	RCC-304RL-MS22F	VF-04	14.0
					3/4	RCC-306RL-MS22F	VF-06	19.0
					1	RCC-308RL-MS22F	VF-08	24.4
				Daiwa Dengyo	16	MSA-16-22	FCV16	15.8
					22	MSA-22-22	FCV22	20.8
HC-SF202(B) to 502(B) HC-RF353(B) to 503(B) HC-UF202(B) to 502(B)	CE05-2A24-10PD-B	MS3106A24-10S(D190)	Straight	Nippon Flex	1/2	RCC-104RL-MS24F	VF-04	14.0
					3/4	RCC-106RL-MS24F	VF-06	19.0
					1	RCC-108RL-MS24F	VF-08	24.4
				Daiwa Dengyo	16	MSA-16-24	FCV16	15.8
					22	MSA-22-24	FCV22	20.8
			Angle	Nippon Flex	1/2	RCC-304RL-MS24F	VF-04	14.0
					3/4	RCC-306RL-MS24F	VF-06	19.0
					1	RCC-308RL-MS24F	VF-08	24.4
				Daiwa Dengyo	16	MSA-16-24	FCV16	15.8
					22	MSA-22-24	FCV22	20.8
HC-SF702(B)	CE05-2A32-17PD-B	MS3106A32-17S(D190)	Straight	Nippon Flex	3/4	RCC-106RL-MS32F	VF-06	19.0
					1	RCC-108RL-MS32F	VF-08	24.4
			Angle	Daiwa Dengyo	3/4	RCC-306RL-MS32F	VF-06	19.0
					1	RCC-308RL-MS32F	VF-08	24.4

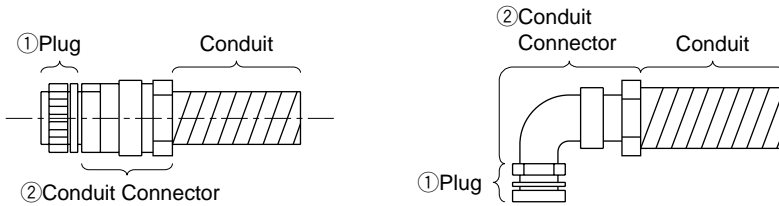
### 3.WIRING

- For encoder connection



Servo Motor	Servo Motor Side Connector	① Plug (Daiichi Denshi Kogyo)	② Conduit Connector				Conduit	
			Type	Maker	Size	Model	Model	ID
HC-SF52(B) to 702(B) HC-RF103(B) to 503(B) HC-UF72(B) to 502(B)	MS3102A20-29P	MS3106A20-29S(D190)	Straight	Nippon Flex	1/2	RCC-104RL-MS20F	VF-04	14.0
					3/4	RCC-106RL-MS20F	VF-06	19.0
				Daiwa Dengyo	16	MSA-16-20	FCV16	15.8
					22	MSA-22-20	FCV22	20.8
			Angle	Nippon Flex	1/2	RCC-304RL-MS20F	VF-04	14.0
					3/4	RCC-306RL-MS20F	VF-06	19.0
Daiwa Dengyo	16	MAA-16-20	FCV16	15.8				
	22	MAA-22-20	FCV22	20.8				

- For brake connection



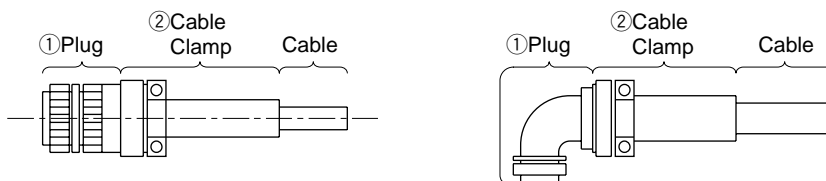
Servo Motor	Servo Motor Side Connector	① Plug (Daiichi Denshi Kogyo)	② Conduit Connector				Conduit	
			Type	Maker	Size	Model	Model	ID
HC-SF202(B) to 702(B) HC-UF202(B) to 502(B)	MS3102A10SL-4P	MS3106A10SL-4S(D190)	Straight	Nippon Flex	1/4	RCC-102RL-MS10F	VF-02	8.3
				Daiwa Dengyo	10	MSA-10-10	FCV10	10.0
			Angle	Nippon Flex	1/4	RCC-302RL-MS10F	VF-02	8.3
				Daiwa Dengyo	10	MAA-10-10	FCV10	10.0

### 3. WIRING

#### 2) Waterproof (IP65)/EN Standard/UL/C-UL Standard-compliant

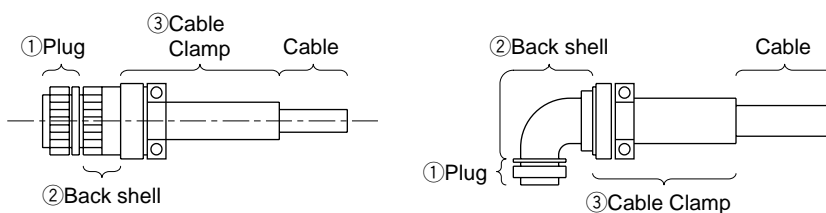
##### a. When using cable type cables

- For power supply connection



Servo Motor	Servo Motor Side Connector	① Plug (Daiichi Denshi Kogyo)		② Cable Clamp (Daiichi Denshi Kogyo)	
		Type	Model	Cable OD	Model
HC-SF52(B) to 152(B)	CE05-2A22-23PD-B	Straight	CE05-6A22-23SD-B-BSS	9.5 to 13	CE3057-12A-2(D265)
HC-RF103(B) to 203(B)		Angle	CE05-8A22-23SD-B-BAS	12.5 to 16	CE3057-12A-1(D265)
HC-UF72(B) • 152(B)					
HC-SF202(B) to 502(B)	CE05-2A24-10PD-B	Straight	CE05-6A24-10SD-B-BSS	13 to 15.5	CE3057-16A-2(D265)
HC-RF353(B) to 503(B)		Angle	CE05-8A24-10SD-B-BAS	15 to 19.1	CE3057-16A-1(D265)
HC-UF202(B) to 502(B)					
HC-SF702(B)	CE05-2A32-17PD-B	Straight	CE05-6A32-17SD-B-BSS	22 to 23.8	CE3057-20A-1(D265)
		Angle	CE05-8A32-17SD-B-BAS	22 to 23.8	CE3057-20A-1(D265)

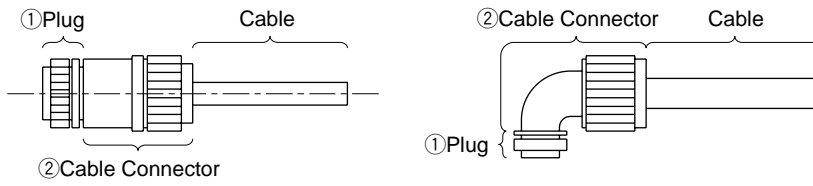
- For encoder connection



Servo Motor	Servo Motor Side Connector	① Plug (Daiichi Denshi Kogyo)	② Back shell (Daiichi Denshi Kogyo)		② Cable Clamp (Daiichi Denshi Kogyo)	
			Type	Model	Cable OD	Model
HC-SF52(B) to 702(B)	MS3102A20-29P	MS3106A20-29S(D190)	Straight	CE02-20BS-S	6.8 to 10	CE3057-12A-3(D265)
HC-RF103(B) to 503(B)			Angle	CE-20BA-S		
HA-UF72(B) to 502(B)						

### 3. WIRING

- For brake connection

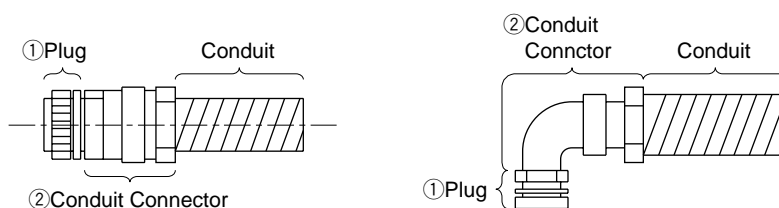


Servo Motor	Servo Motor Side Connector	① Plug (Daichi Denshi Kogyo)	② Cable Connector			
			Type	Maker	Cable OD	Model
HC-SF202(B) to 702(B) HC-UF202(B) to 502(B)	MS3102A10SL-4P	MS3106A10SL-4S(D190)	Straight	Nippon Flex	4 to 8	ACS-08RL-MS10F
					8 to 12	ACS-12RL-MS10F
				Daiwa Dengyo	5 to 8.3	YS0-10-5 to 8
			Angle	Nippon Flex	4 to 8	ACA-08RL-MS10F
					8 to 12	ACA-12RL-MS10F
				Daiwa Dengyo	5 to 8.3	YL0-10-5 to 8



### 3.WIRING

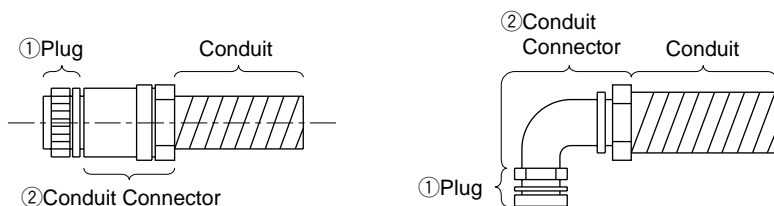
- b. When using flexible conduits  
 • For power supply connection



Servo Motor	Servo Motor Side Connector	① Plug (Daiichi Denshi Kogyo)	② Conduit Connector				Conduit	
		Model	Type	Maker	Size	Model	Model	ID
HC-SF52(B) to 152(B) HC-RF103(B) to 203(B) HC-UF72(B) • 152(B)	CE05-2A22-23PD-B	CE05-6A22-23SD-B	Straight	Nippon Flex	1/2	RCC-104RL-MS22F	VF-04	14.0
					3/4	RCC-106RL-MS22F	VF-06	19.0
					1	RCC-108RL-MS22F	VF-08	24.4
				Daiwa Dengyo	16	MSA-16-22	FCV16	15.8
					22	MSA-22-22	FCV22	20.8
			Angle	Nippon Flex	1/2	RCC-304RL-MS22F	VF-04	14.0
					3/4	RCC-306RL-MS22F	VF-06	19.0
					1	RCC-308RL-MS22F	VF-08	24.4
				Daiwa Dengyo	16	MAA-16-22	FCV16	15.8
					22	MAA-22-22	FCV22	20.8
HC-SF202(B) to 502(B) HC-RF353(B) to 503(B) HC-UF202(B) to 502(B)	CE05-2A24-10PD-B	CE05-6A24-10SD-B	Straight	Nippon Flex	1/2	RCC-104RL-MS24F	VF-04	14.0
					3/4	RCC-106RL-MS24F	VF-06	19.0
					1	RCC-108RL-MS24F	VF-08	24.4
				Daiwa Dengyo	16	MSA-16-24	FCV16	15.8
					22	MSA-22-24	FCV22	20.8
			Angle	Nippon Flex	1/2	RCC-304RL-MS24F	VF-04	14.0
					3/4	RCC-306RL-MS24F	VF-06	19.0
					1	RCC-308RL-MS24F	VF-08	24.4
				Daiwa Dengyo	16	MAA-16-24	FCV16	15.8
					22	MAA-22-24	FCV22	20.8
HC-SF702(B)	CE05-2A32-17PD-B	CE05-6A32-17SD-B	Straight	Nippon Flex	3/4	RCC-106RL-MS32F	VF-06	19.0
					1	RCC-108RL-MS32F	VF-08	24.4
			Angle	Daiwa Dengyo	3/4	RCC-306RL-MS32F	VF-06	19.0
					1	RCC-308RL-MS32F	VF-08	24.4

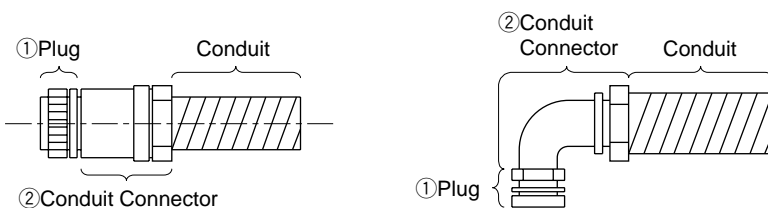
### 3.WIRING

- For encoder connection



Servo Motor	Servo Motor Side Connector	① Plug (Daiichi Denshi Kogyo)	② Conduit Connector				Conduit	
		Model	Type	Maker	Size	Model	Model	ID
HC-SF52(B) to 702(B) HC-RF103(B) to 503(B) HC-UF72(B) to 502(B)	MS3102A20-29P	MS3106A20-29S(D190)	Straight	Nippon Flex	1/2	RCC-104RL-MS20F	VF-04	14.0
					3/4	RCC-106RL-MS20F	VF-06	19.0
				Daiwa Dengyo	16	MSA-16-20	FCV16	15.8
					22	MSA-22-20	FCV22	20.8
			Angle	Nippon Flex	1/2	RCC-304RL-MS20F	VF-04	14.0
					3/4	RCC-306RL-MS20F	VF-06	19.0
Daiwa Dengyo	16	MAA-16-20	FCV16	15.8				
	22	MAA-22-20	FCV22	20.8				

- For brake connection

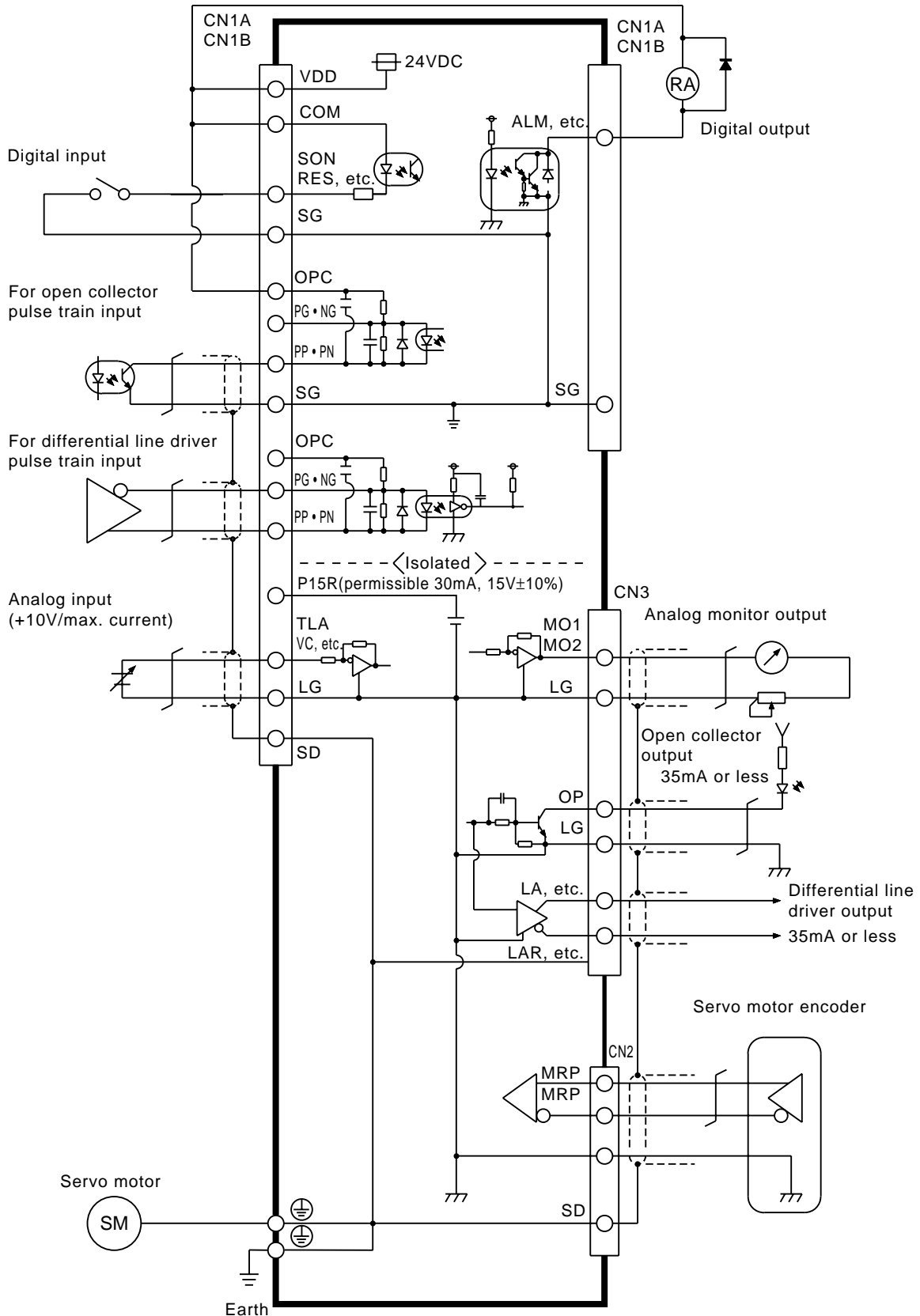


Servo Motor	Servo Motor Side Connector	① Plug (Daiichi Denshi Kogyo)	② Conduit Connector				Conduit	
		Model	Type	Maker	Size	Model	Model	ID
HC-SF202(B) to 702(B) HC-UF202(B) to 502(B)	MS3102A10SL-4P	MS3106A10SL-4S(D190)	Straight	Nippon Flex	1/4	RCC-102RL-MS10F	VF-02	8.3
				Daiwa Dengyo	10	MSA-10-10	FCV10	10.0
			Angle	Nippon Flex	1/4	RCC-302RL-MS10F	VF-02	8.3
				Daiwa Dengyo	10	MAA-10-10	FCV10	10.0

# 3.WIRING


## 3-3 Common line

The power supply and its common line are shown below.



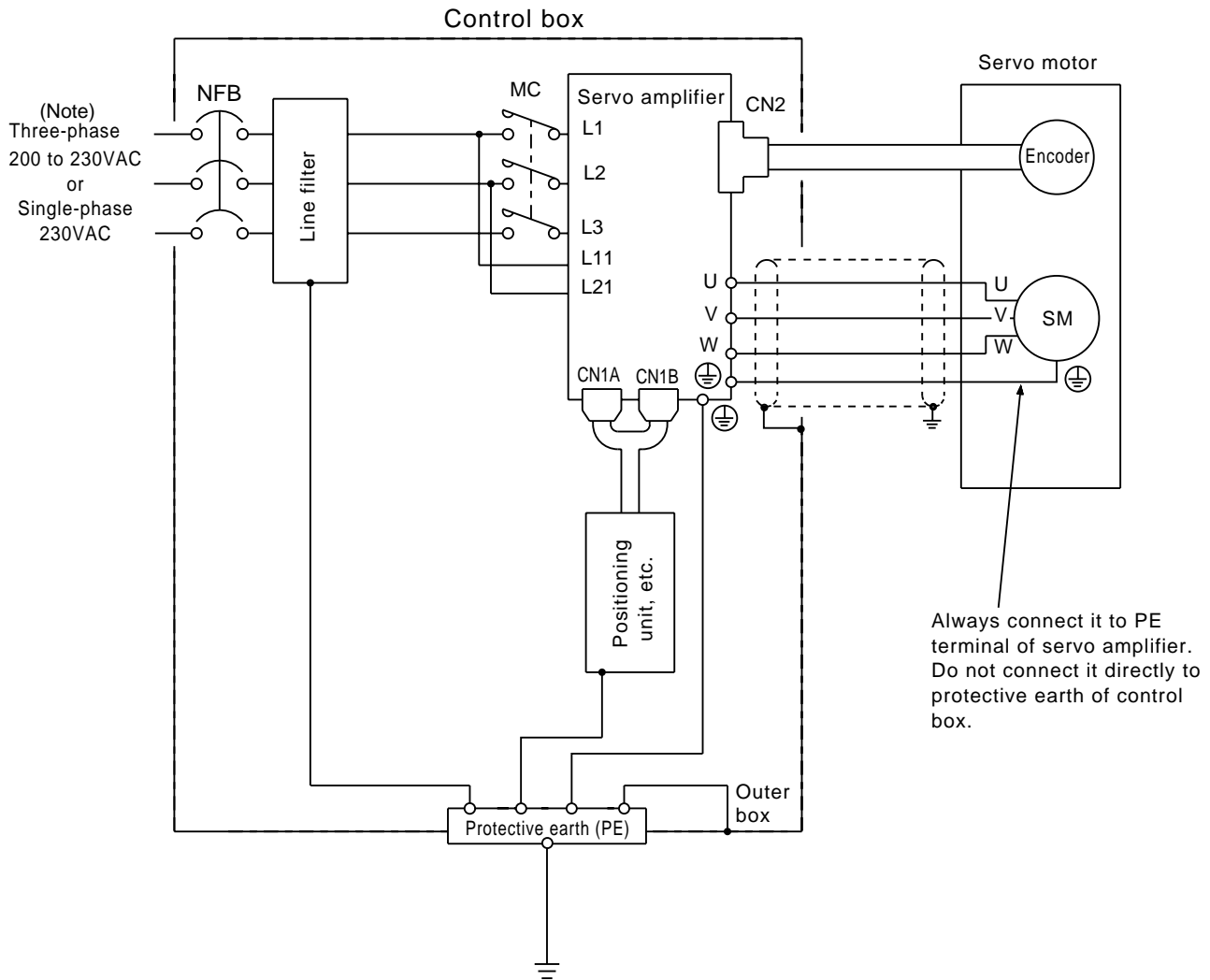
# 3.WIRING

## 3-4 Grounding

 <b>WARNING</b>	<ol style="list-style-type: none"> <li>1. Ground the servo amplifier and servo motor securely.</li> <li>2. To prevent an electric shock, always connect the protective earth (PE) terminal (marked <math>\oplus</math>) of the servo amplifier with the protective earth (PE) of the control box.</li> </ol>
--	--

The servo amplifier switches the power transistor on-off to supply power to the servo motor. Depending on the wiring and ground cablerouting, the servo amplifier may be affected by the switching noise (due to di/dt and dv/dt) of the transistor. In order to prevent such trouble from occurring, ensure to connect an earth referring to the drawing shown below.

To conform to the EMC Directive, refer to the EMC INSTALLATION GUIDELINES (IB(NA)67310).



Note: When using a power supply of 230VAC, single phase, connect it to L1 and L2 terminals, but do not connect anything to L3 terminal.

# 3.WIRING

## 3-5 Power supply circuit

**CAUTION**

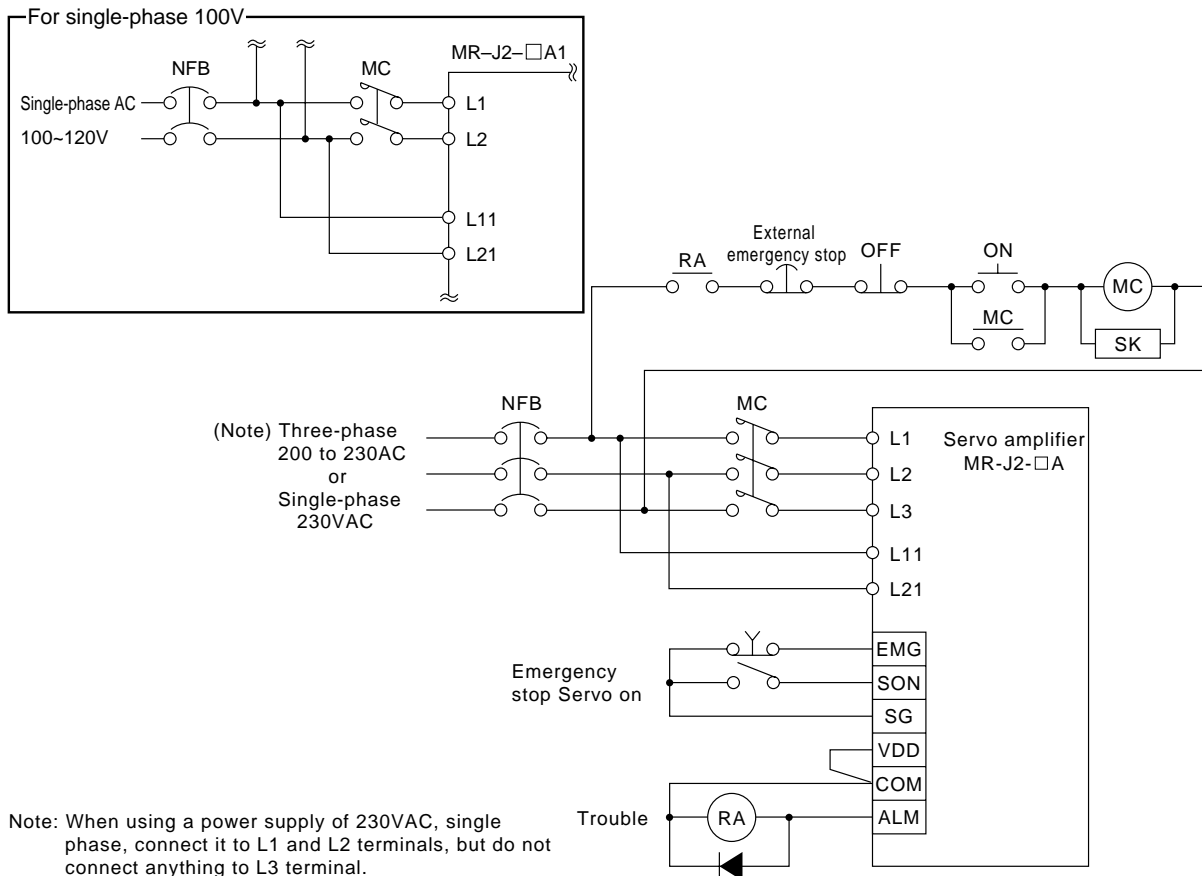
1. When the servo amplifier has become faulty, switch power off on the servo amplifier power side. Continuous flow of a large current may cause a fire.
2. Use the trouble signal to switch power off. Otherwise, a regenerative brake transistor fault or the like may overheat the regenerative brake resistor, causing a fire.

(1) Power-on sequence

- 1) Always wire the power supply as shown below using magnetic contactors with the main circuit power supply (three-phase 200V: L1, L2, L3; single-phase 230V: L1, L2; single-phase 100V: L1, L2).
- 2) Switch on the control circuit power supply L11, L21 simultaneously with the main circuit power supply or before switching on the main circuit power supply. If the main circuit power supply is not on, the display shows the corresponding warning. However, by switching on the main circuit power supply, the warning disappears and the servo amplifier will operate properly.
- 3) The servo amplifier can accept the servo-on signal (SON) about 1 second after the main circuit power supply is switched on. Therefore, when SON is switched on simultaneously with the three-phase power supply, the base circuit will switch on in about 1 second, and the ready signal (RD) will switch on in further about 20ms, making the servo amplifier ready to operate. (Refer to paragraph (2) in this section.)
- 4) When the reset signal (RES) is switched on, the base circuit is shut off and the servo motor shaft coasts.
- 5) For the structure of the external circuit, refer to Section 2-1.

(2) Connection example

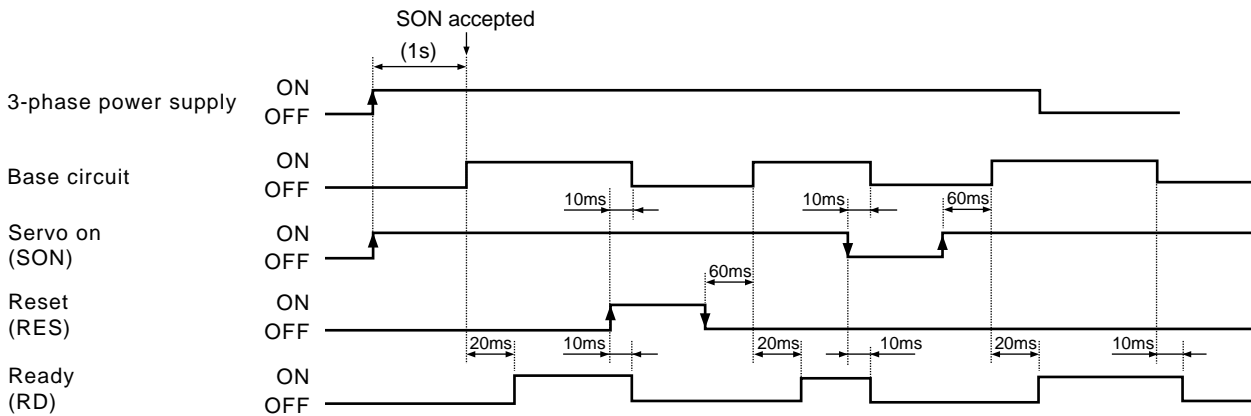
Wire the power supply and main circuits as shown below. A no-fuse breaker (NFB) must be used with the input cables of the power supply. Immediately after the occurrence of alarm is detected and the power supply is cut out, the servo ON signal must be turned off.



Note: When using a power supply of 230VAC, single phase, connect it to L1 and L2 terminals, but do not connect anything to L3 terminal.

### 3.WIRING

#### (3) Timing chart

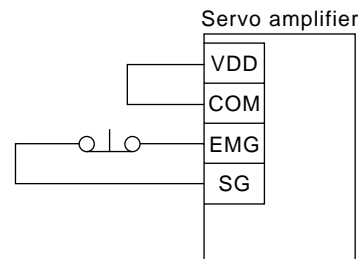


Power ON Timing Chart

#### (4) Emergency stop

To ensure safety, always install an emergency stop switch across EMG-SG. By disconnecting EMG-SG, the dynamic brake is operated to bring the servo motor to a sudden stop. At this time, the display shows the servo emergency stop warning (A. E6).

During ordinary operation, do not use the emergency stop signal to alternate stop and run. The service life of the servo amplifier may be shortened. Also, if the start signal is on or a pulse train is input during an emergency stop, the servo motor will rotate as soon as the warning is reset. During an emergency stop, always shut off the run command.



## 3.WIRING

### 3-6 Alarm occurrence timing chart

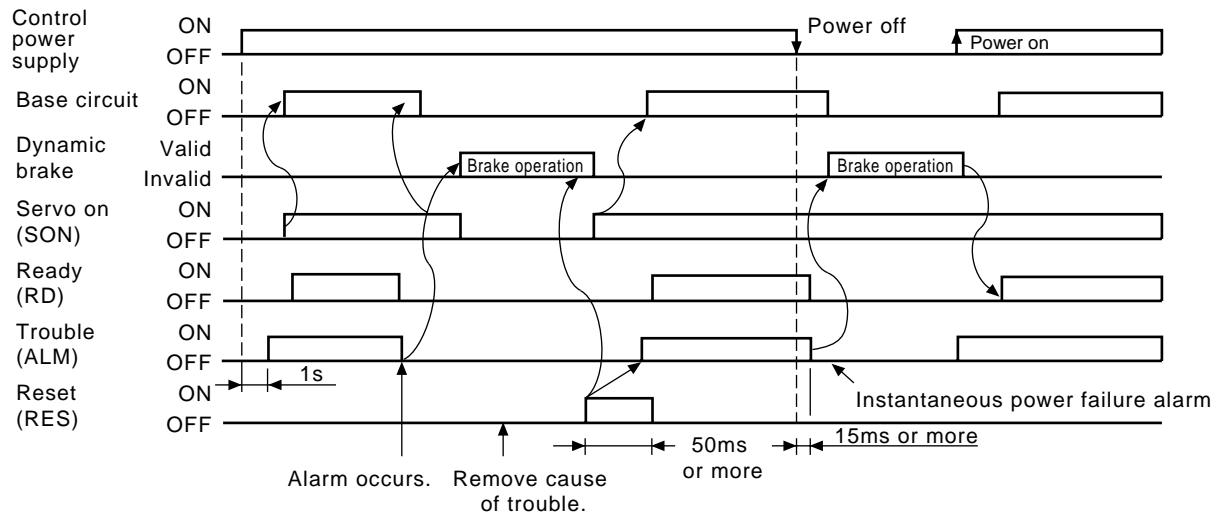


#### CAUTION

When an alarm has occurred, remove its cause, make sure that the operation signal is not being input, ensure safety, and reset the alarm before restarting operation.

When an alarm occurs in the servo amplifier, the base circuit is shut off and the servo motor is coated to a stop. Switch off the main circuit power supply in the external sequence. To reset the alarm, switch the control circuit power supply off, then on.

However, the alarm cannot be reset unless its cause of occurrence is removed.



#### Precautions for alarm occurrence

##### 1) Overcurrent, overload 1 or overload 2

If operation is repeated by switching control circuit power off, then on to reset the overcurrent (A. 32), overload 1 (A. 50) or overload 2 (A. 51) alarm after its occurrence, without removing its cause, the servo amplifier and servo motor may become faulty due to temperature rise. Securely remove the cause of the alarm and also allow about 30 minutes for cooling before resuming operation.

##### 2) Regenerative alarm

If operation is repeated by switching control circuit power off, then on to reset the regenerative (A. 30) alarm after its occurrence, the external regenerative brake resistor will generate heat, resulting in an accident.

##### 3) Instantaneous power failure

Undervoltage (A. 10) occurs if power is restored after a 100ms or longer power failure of the control power supply or after a drop of the bus voltage to or below 200VDC. If the power failure persists further, the control power switches off. When the power failure is reset in this state, the alarm is reset and the servo motor will start suddenly if the servo-on signal (SON) is on. To prevent hazard, make up a sequence which will switch off the servo-on signal (SON) if an alarm occurs.

##### 4) Position control mode

When an alarm occurs, the home position is lost. When resuming operation after resetting the alarm, make a return to home position.

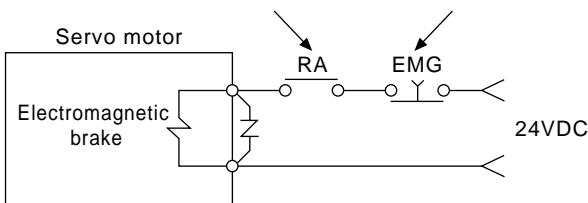
# 3.WIRING

## 3-7 Servo motor with electromagnetic brake

1. Make up the electromagnetic brake operation circuit so that it is activated not only by the servo amplifier signals but also by an external emergency stop signal.

Shut off by servo-on signal OFF, alarm or electromagnetic brake signal.      Shut off by emergency stop signal (EMG).

**CAUTION**

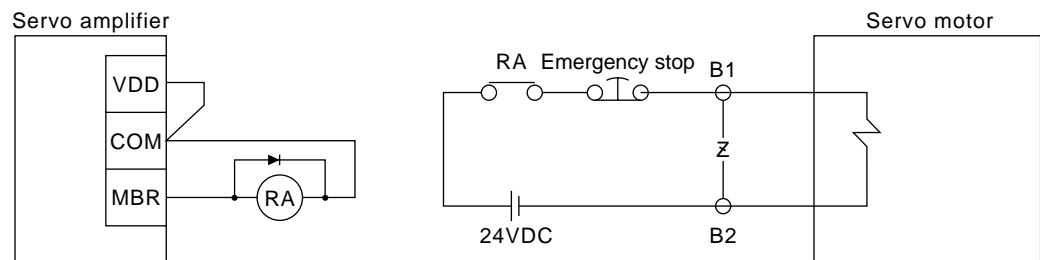


2. The electromagnetic brake is provided for holding the motor shaft. Do not use it for ordinary braking.

Note the following when the servo motor equipped with electromagnetic brake is used for applications requiring a brake to hold the motor shaft (vertical lift applications):

- 1) Set 1 in parameter No. 1 to make the electromagnetic brake interlock signal (MBR) valid. Note that this will make the zero speed signal (ZSP) unavailable.
- 2) Do not share the 24VDC power supply between the interface and electromagnetic brake. Always use the power supply designed exclusively for the electromagnetic brake.
- 3) The brake will operate when the power (24VDC) switches off.
- 4) Turn off the servo on signal after the servo motor has stopped.

(1) Connection diagram



(2) Setting procedure

- 1) Set 1 in parameter No. 1 to make the electromagnetic brake interlock signal (MBR) valid.
- 2) Using parameter No. 33 (electromagnetic brake sequence output), set a time delay from electromagnetic brake operation to base circuit shut-off as in the timing chart shown in (3) in this section.

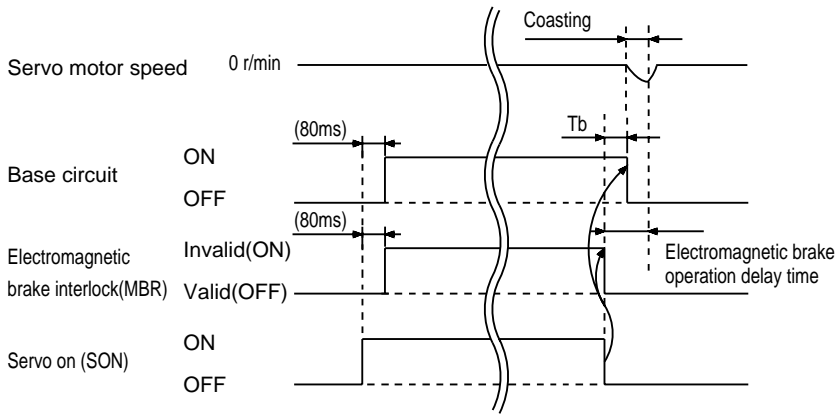


### 3.WIRING

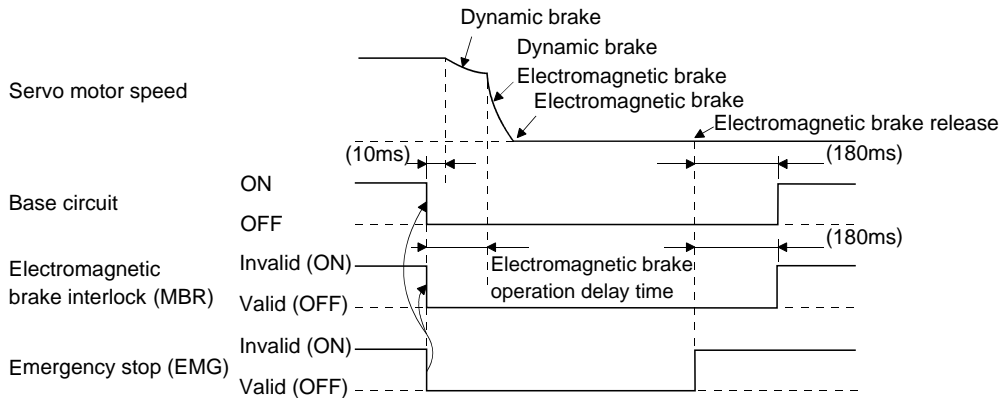
#### (3) Timing charts

##### (a) Servo-on signal (SON) ON/OFF

T<sub>b</sub> (ms) after the servo-on (SON) signal is switched off, the servo lock is released and the servo motor coasts. If the electromagnetic brake is made valid in the servo lock status, the brake life may be shorter. Therefore, when using the electromagnetic brake in a vertical lift application or the like, set T<sub>b</sub> to about the same as the electromagnetic brake operation delay time to prevent a drop.

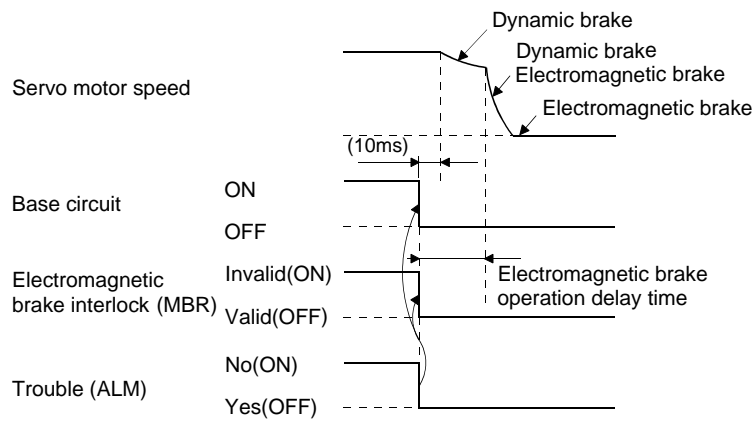


##### (b) Emergency stop signal (EMG) ON/OFF

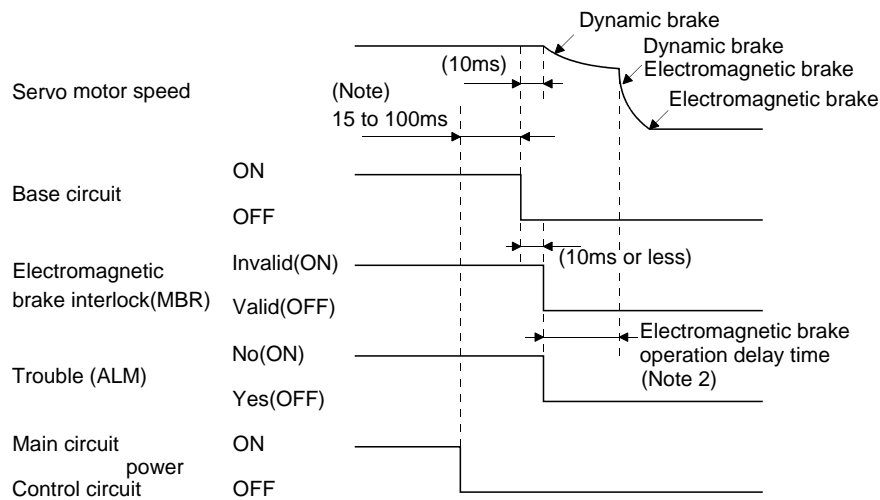


### 3.WIRING

#### (c) Alarm occurrence

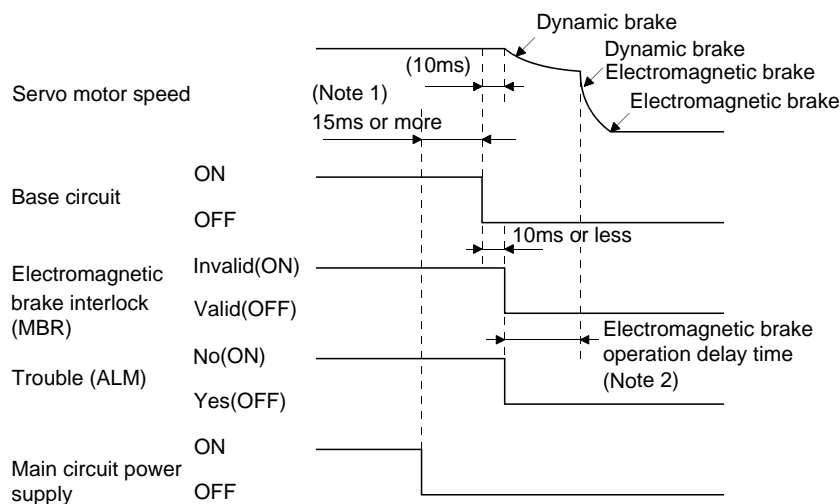


#### (d) Both main and control circuit power supplies off



Note: Changes with the operating status.

#### (e) Only main circuit power supply off (control circuit power supply remains on)



Note: 1. Changes with the operating status.

2. When the main circuit power supply is off in a motor stop status, the main circuit off warning (A.E9) occurs and the ALM signal does not turn off.

# CHAPTER 4

## INSTALLATION

---

This chapter deals with the installation method and environmental conditions. Follow the instructions in this chapter when installing the equipment.

- 4-1 Servo amplifier
- 4-2 Servo motor

<b>INTRODUCTION</b>	<b>CHAPTER 1</b>
<b>OPERATION</b>	<b>CHAPTER 2</b>
<b>WIRING</b>	<b>CHAPTER 3</b>
<b>INSTALLATION</b>	<b>CHAPTER 4</b>
<b>ABSOLUTE POSITION DETECTION SYSTEM</b>	<b>CHAPTER 5</b>
<b>OPTIONS AND AUXILIARY EQUIPMENT</b>	<b>CHAPTER 6</b>
<b>INSPECTION</b>	<b>CHAPTER 7</b>
<b>TROUBLESHOOTING</b>	<b>CHAPTER 8</b>
<b>CHARACTERISTICS</b>	<b>CHAPTER 9</b>
<b>SPECIFICATIONS</b>	<b>CHAPTER 10</b>
<b>SELECTION</b>	<b>CHAPTER 11</b>

## 4.INSTALLATION

 **CAUTION**

1. Stacking in excess of the limited number of products is not allowed.
2. Install the equipment to incombustibles. Installing them directly or close to combustibles will led to a fire.
3. Install the equipment in a load-bearing place in accordance with this Installation Guide.
4. Do not get on or put heavy load on the equipment to prevent injury.
5. Use the equipment within the specified environmental condition range.
6. Provide an adequate protection to prevent screws, metallic detritus and other conductive matter or oil and other combustible matter from entering the servo amplifier.
7. Do not block the intake/exhaust ports of the servo amplifier. Otherwise, a fault may occur.
8. Do not subject the servo amplifier and servo motor to drop impact or shock loads as they are precision equipment.
9. Do not install or operate a faulty servo amplifier or servo motor.
10. When the product has been stored for an extended period of time, consult Mitsubishi.

### 4-1 Servo amplifier

 **CAUTION**

1. The equipment must be installed in the specified direction. Otherwise, a fault may occur.
2. Leave specified clearances between the servo amplifier and control box inside walls or other equipment.

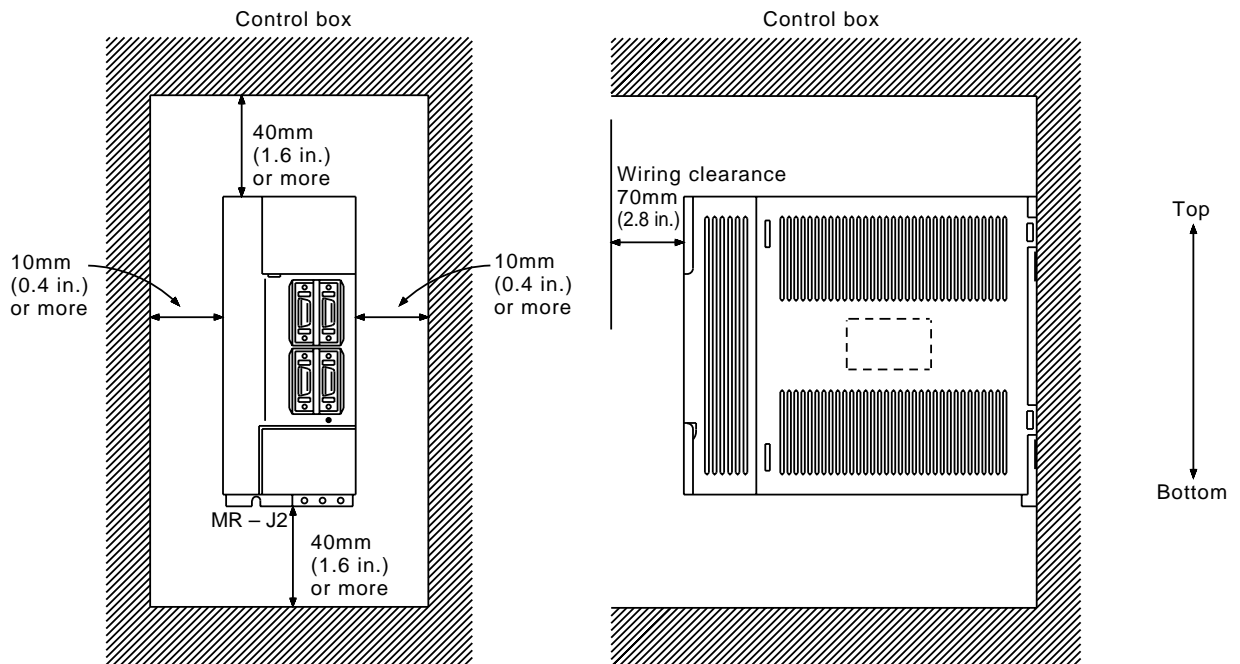
#### (1) Environmental conditions

Environment	Conditions
Ambient temperature	0 to +55 [°C] (non-freezing)
	32 to +131 [°F] (non-freezing)
Ambient humidity	90%RH or less (non-condensing)
storage temperature	-20 to +65 [°C] (non-freezing)
	-4 to +149 [°F] (non-freezing)
storage humidity	90%RH or less (non-condensing)
Ambient	Indoors (no direct sunlight) Free from corrosive gas, flammable gas, oil mist, dust and dirt
Altitud	Max. 1000m (3280 ft) above sea level
Vibration	5.9 [m/s <sup>2</sup> ] or less
	19.4 [ft/s <sup>2</sup> ] or less

## 4.INSTALLATION

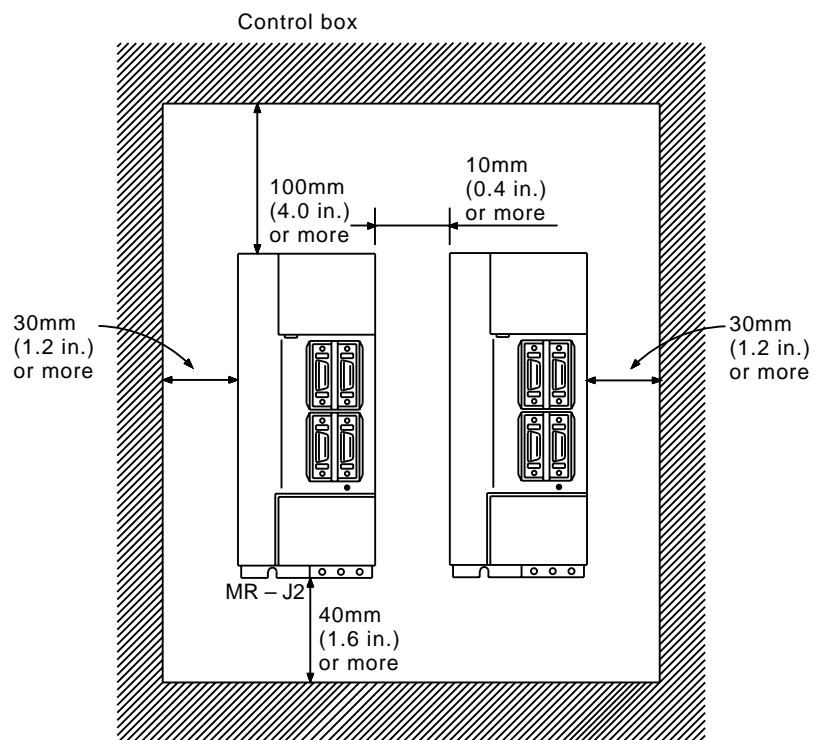
### (2) Installation direction and clearances

#### 1) Installation of one servo amplifier



#### 2) Installation of two or more servo amplifiers

Leave a large clearance between the top of the servo amplifier and the internal surface of the control box, and install a fan to prevent the internal temperature of the control box from exceeding the environmental conditions.



## 4.INSTALLATION

---

### 3) Others

When using heat generating equipment such as the regenerative brake option, install them with full consideration of heat generation so that the servo amplifier is not affected.

Install the servo amplifier on a perpendicular wall in the correct vertical direction.

### (2) Keep out foreign materials

1) When installing the unit in a control box, prevent drill chips and wire fragments from entering the servo amplifier.

2) Prevent oil, water, metallic dust, etc. from entering the servo amplifier through openings in the control box or a fan installed on the ceiling.

3) When positioning the control panel in a place where there is much harmful gas or dust, perform an air purge (force-feed clean air from the outside of the control panel to increase the inside air pressure more than the outside air pressure) to prevent harmful gas or dust from entering the control panel.

## 4.INSTALLATION

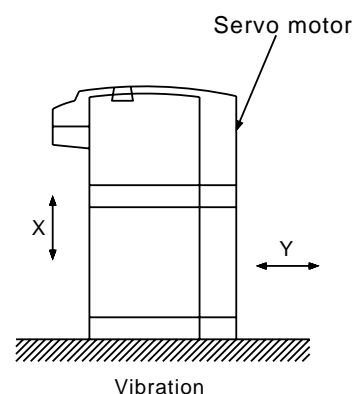
### 4-2 Servo motor

**CAUTION**

1. Do not hold the cable, shaft or encoder to carry the servo motor. Otherwise, a fault or injury may occur.
2. Securely fix the servo motor to the machine. If fixed insecurely, the servo motor will come off during operation, leading to injury.
3. When coupling the shaft end of the servo motor, do not subject the shaft end to impact, such as hammering. The encoder may become faulty.
4. Cover the shaft of the servo motor to make its rotary part completely inaccessible during operation.
5. Do not subject the servo motor shaft to more than the permissible load. Otherwise, the shaft may break, leading to injury.

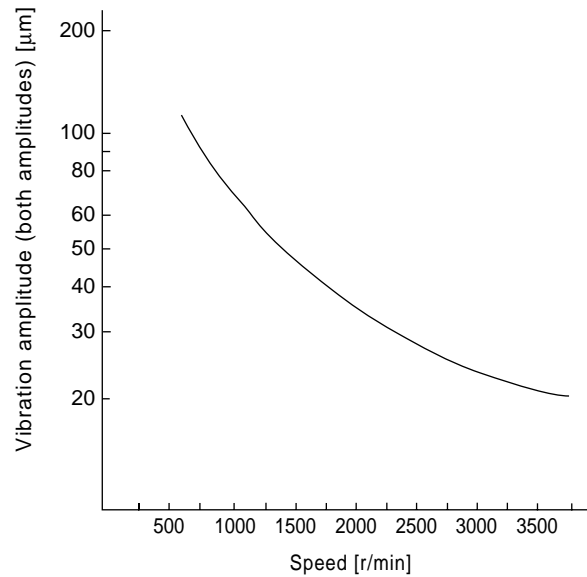
#### (1) Environmental conditions

Environment		Conditions	
Ambient temperature	[°C]	0 to +40 (non-freezing)	
	[°F]	32 to +104 (non-freezing)	
Ambient humidity		80%RH or less (non-condensing)	
Storage temperature	[°C]	-15 to +70 (non-freezing)	
	[°F]	5 to 158 (non-freezing)	
Storage humidity		90%RH or less (non-condensing)	
Ambient		Indoors (no direct sunlight) Free from corrosive gas, flammable gas, oil mist, dust and dirt	
Altitude		Max. 1000m (3280ft) above sea level	
Vibration	[m/s <sup>2</sup> ]	MC-MF series HA-FF series HU-UF13 to 73	X-Y: 19.6
		HC-SF81 HC-SF52 to 152 HC-SF53 to 153 HC-RF series HC-UF72-152	X: 9.8 Y: 24.5
		HC-SF121-201 HC-SF202-352 HC-SF203-353 HC-UF202	X: 19.6 Y: 49
		HC-SF301	X: 11.7 Y: 29.4
		MC-MF series HA-FF series HU-UF13 to 73	X-Y: 64
		HC-SF81 HC-SF52 to 152 HC-SF53 to 153 HC-RF series HC-UF72-152	X: 32 Y: 80
	[ft/s <sup>2</sup> ]	HC-SF121-201 HC-SF202-352 HC-SF203-353 HC-UF202	X: 64 Y: 161
		HC-SF301	X: 38 Y: 96



Graph of vibration servo amplitude vs. speed

## 4.INSTALLATION



### (2) Transportation

Do not hold the encoder or shaft to carry the servo motor.

### (3) Load mounting precautions (Prevention of impact on shaft)

1) When mounting a pulley to the servo motor shaft provided with a keyway, use the screw hole in the shaft end. To fit the pulley, first insert a double-end stud into the screw hole of the shaft, put a washer against the end face of the coupling, and insert and tighten a nut to force the pulley in.

2) For the servo motor shaft with a keyway, use the screw hole in the shaft end. For the shaft without a keyway, use a friction coupling or the like.

3) When removing the pulley, use a pulley remover to protect the shaft from impact.

4) To ensure safety, fit a protective cover or the like on the rotary area, such as the pulley, mounted to the shaft.

5) When a threaded shaft end part is needed to mount a pulley on the shaft, please contact us.

6) During assembling, the shaft end must not be hammered.

7) The orientation of the encoder on the servo motor cannot be changed.

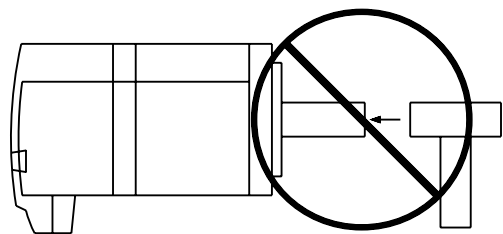
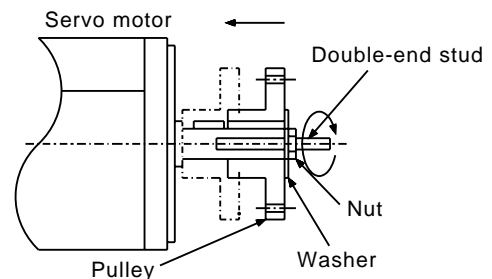
8) For installation of the servo motor, use spring washers, etc. and fully tighten the bolts so that they do not become loose due to vibration.

### (4) Permissible load for the shaft

1) Use a flexible coupling and make sure that the misalignment of the shaft is less than the permissible radial load.

2) When using a pulley, sprocket or timing belt, select a diameter that will fit into the permissible radial load.

3) Do not use a rigid coupling as it may apply excessive bending load to the shaft, leading to shaft breakage.

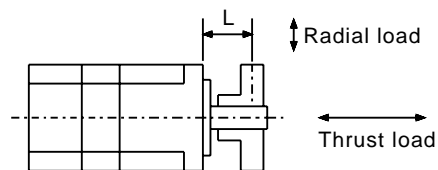




## 4.INSTALLATION

Servo Motor		L		Radial load		Thrust load	
		[mm]	[in]	[N]	[lb]	[N]	[lb]
HC-MF	053-13	25	1.0	88	19.8	59	13.3
	23-43	30	1.2	245	55.1	98	22.0
	73	40	1.6	392	88.2	147	33.1
HA-FF	053	30	1.2	108	24.3	98	22.0
	13	30	1.2	118	26.5	98	22.0
	23 · 33	30	1.2	176	39.6	147	33.1
	43 · 63	40	1.6	323	72.7	284	63.9
HC-SF	81	55	2.17	980	220	490	110
	121 to 301	79	3.11	2058	463	980	220
	52 to 152	55	2.2	980	220.5	490	110.2
	202-352	79	3.1	2058	463.0	980	220.5
	53 to 153	55	2.17	980	220	490	110
	203-353	79	3.11	2058	463	980	220
HC-RF	103 to 203	45	1.8	686	154.3	196	44.1
HC-UF	72-152	55	2.17	637	143	490	110
	202	65	2.56	882	198	784	176
	13	25	0.98	88	20	59	13
	23-43	30	1.18	245	55	98	22
	73	40	1.57	392	88	147	33

Note: For the symbols in the table, refer to the following diagram:

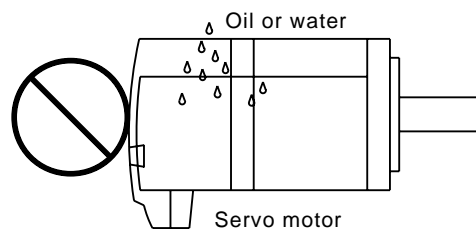


L: Distance from flange mounting surface to load center

### (5) Protection from oil and water

- 1) The HC-MF/HA-FF series servo motor is not waterproof (IP44). Do not subject the servo motor to oil and water.

Servo Motor Series	Protection
HC – MF•HA – FF	IP44
HC – SF•HA – RF	IP65

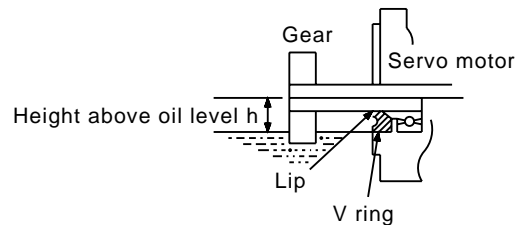


## 4.INSTALLATION

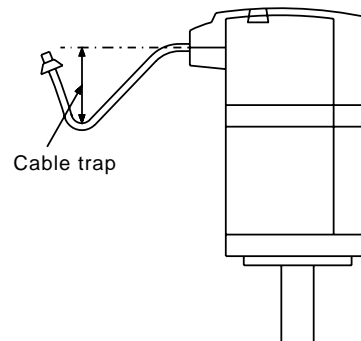
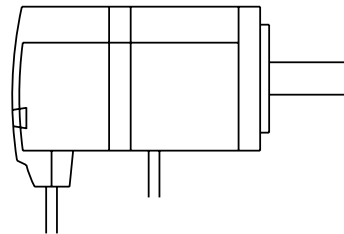
- 2) When the gear box is mounted horizontally, the oil level in the gear box should always be lower than the oil seal lip on the servo motor shaft. If it is higher than the oil seal lip, oil will enter the servo motor, leading to a fault. Also, provide a breathing hole in the gear box to hold the internal pressure low.

The HC-MF series servo motor is not equipped with a V ring or an oil seal and cannot be used with the gear box as described above. Oil should be shut off on the gear box side. Some HA-FF series servo motors are equipped with an oil seal. Please contact Mitsubishi.

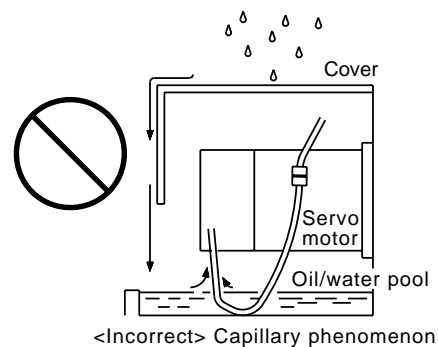
Servo Motor	Height above Oil Level h [mm] ([in])	
HA-FF	053 · 13	8 (0.32)
	23 · 33	12 (0.48)
	43 · 63	14 (0.56)
HC-SF	81	20 (0.79)
	121 to 301	25 (0.98)
	52 to 152	20 (0.79)
	202 · 352	25 (0.99)
	53 to 153	20 (0.79)
	203 · 353	25 (0.98)
HC-RF	103 to 203	20 (0.79)
HC-UF	72 · 152	20 (0.79)
	202 to 502	25 (0.98)
	13	12 (0.47)
	23 · 43	14 (0.55)
	73	20 (0.79)



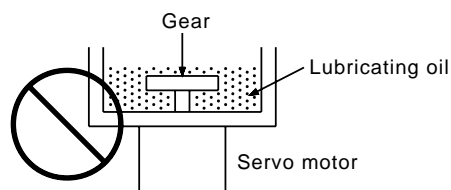
- 3) When installing the servo motor horizontally, face the power cable and encoder cable downward. When installing the servo motor vertically or obliquely, provide a trap for the cable.



- 4) Do not use the servo motor with its cable soaked in oil or water. (Figure on the right)



- 5) When the servo motor is to be installed with the shaft end at top, provide measures to prevent oil from entering the servo motor from the gear box, etc.



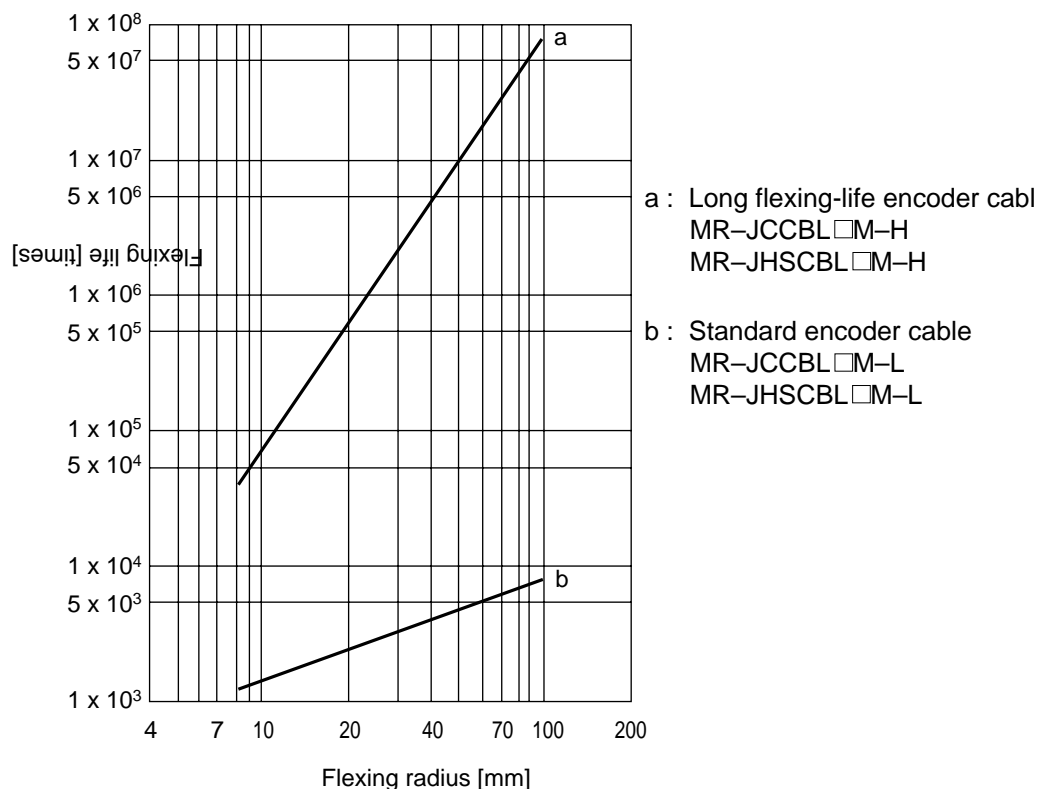
## 4.INSTALLATION

### (6) Installation orientation

The servo motor may be installed in any orientation. When the servo motor with electromagnetic brake is installed with the shaft end at top, the brake plate may generate sliding sound but it is not a fault. Refer to Section 10-3 for the installation orientation of the servo motor with reduction gear.

### (7) Cable stress

- 1) The way of clamping the cable must be fully examined so that flexing stress and cable's own weight stress are not applied to the cable connection.
- 2) In any application where the servo motor moves, the cables should be free from excessive stress. When using the servo motor in an application where the servo motor itself may cause a movement, design the cable so that the service life of the bent part of the cable comes within the service life of the bent part of the detector cable. Fix the encoder cable and power cable of the servo motor.
- 3) Avoid any probability that the cable sheath might be cut by sharp chips, rubbed by a machine corner or stamped by workers or vehicles.
- 4) The flexing lives of the cables are shown below. In actuality, provide a little allowance for these values. For installation on a machine where the servo motor will move, the flexing radius should be made as large as possible.



Note: This graph gives calculated values which are not guaranteed.

Flexing Lives of Encoder Cables

# CHAPTER 5

## ABSOLUTE POSITION DETECTION SYSTEM

---

This chapter provides how to build an absolute position detection system. This servo amplifier will make up an absolute position detection system by merely installing a battery. For more information, refer to the MR-J2-A Absolute Position Detection System Installation Guide (IB(NA)67309).

- (1) Restrictions on absolute position detection system
- (2) Specifications
- (3) Structure
- (4) Overview of absolute position detection data communication
- (5) Battery installation procedure
- (6) Parameter setting
- (7) Connection example

<b>INTRODUCTION</b>	<b>CHAPTER 1</b>
<b>OPERATION</b>	<b>CHAPTER 2</b>
<b>WIRING</b>	<b>CHAPTER 3</b>
<b>INSTALLATION</b>	<b>CHAPTER 4</b>
<b>ABSOLUTE POSITION DETECTION SYSTEM</b>	<b>CHAPTER 5</b>
<b>OPTIONS AND AUXILIARY EQUIPMENT</b>	<b>CHAPTER 6</b>
<b>INSPECTION</b>	<b>CHAPTER 7</b>
<b>TROUBLESHOOTING</b>	<b>CHAPTER 8</b>
<b>CHARACTERISTICS</b>	<b>CHAPTER 9</b>
<b>SPECIFICATIONS</b>	<b>CHAPTER 10</b>
<b>SELECTION</b>	<b>CHAPTER 11</b>

## 5.ABSOLUTE POSITION DETECTION SYSTEM

### (1) Restrictions on absolute position detection system

An absolute position detection system cannot be built under the following conditions:

- 1) Speed control or torque control operation
- 2) Control change mode (position/speed, position/torque)
- 3) Stroke-less coordinate system, e.g. rotary shaft, infinite positioning.
- 4) Restart after instantaneous power failure is made valid for operation.
- 5) Use of alarm code output

### (2) Specifications

Item	Description
System	Electronic battery backup system
Battery	1 piece of lithium battery (primary battery, nominal + 3.6V) Type: MR-BAT or A6BAT
Encoder resolution	Refer to (2) in Section 10-1.
Maximum revolution range	Home position $\pm$ 32767 rev.
(Note 1) Maximum speed at power failure	500r/min
(Note 2) Battery backup time	Approx. 10,000 hours (battery life with power off)
(Note 3) Data holding time during battery replacement	2 hours at delivery, 1 hour in 5 years after delivery
Battery storage period	5 years from date of manufacture

Note: 1. Maximum speed available when the shaft is rotated by external force at the time of power failure or the like.

2. Time to hold data by a battery with power off.

3. Period during which data can be held by the super capacitor in the encoder after power-off, with the battery voltage low or the battery removed, or during which data can be held with the encoder cable disconnected. Battery replacement should be finished within this period.

### (3) Structure

#### 1) Components

Component	Description
Servo amplifier	Use standard models.
Servo motor	
Battery	MR-BAT or A6BAT
Encoder cable	Use a standard model. When fabricating, refer to (2), Section 6-1-2.
General-purpose programmable controller	Use I/O unit (3 input points, 2 output points) to transfer absolute position detection data.

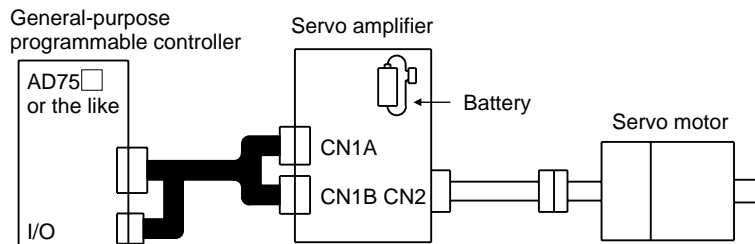
## 5.ABSOLUTE POSITION DETECTION SYSTEM

### 2) Applicable general-purpose programmable controller units

Positioning Unit	I/O Unit
AD71 · AD71S2 · AD71S7 A1SD71S2 · A1SD71S7 AD75P□ · A1SD75P□	AX40 · 41 · 42 AY40 · 41 · 42
FX-1PG · FX-1GM FX(E)-20GM · FX-10GM	FX2-32MT

- Note: 1. The A0J2CPU cannot be used.  
 2. For the availability of the units not listed above, consult Mitsubishi.  
 3. The absolute position detection program is not required for the FX-1GM, FX(E)-20GM and FX-10GM.

### Configuration



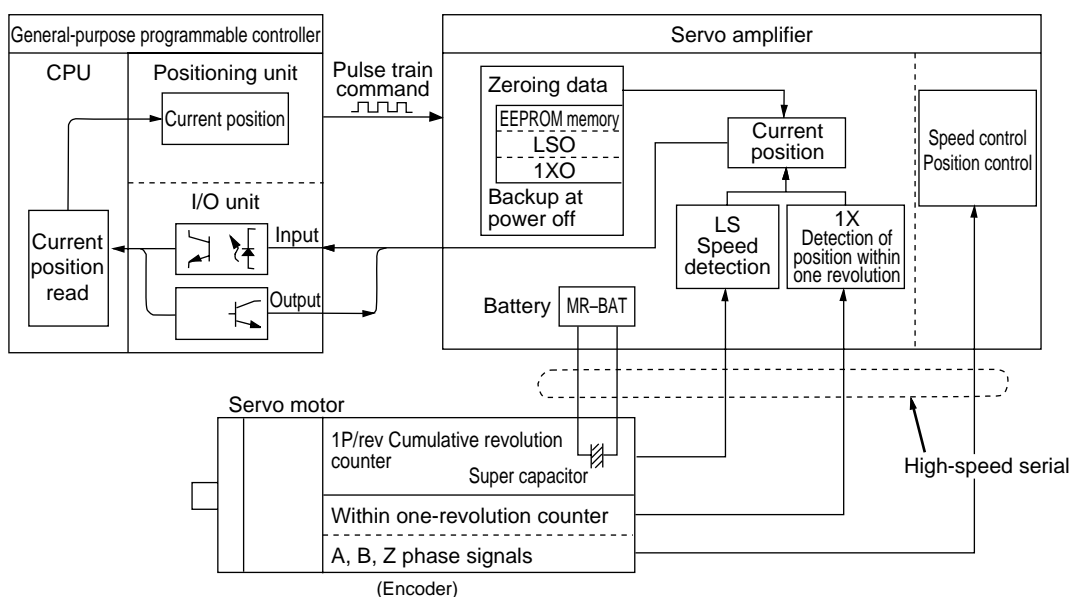
### (4) Overview of absolute position detection data communication

#### 1) System block diagram

As shown below, the encoder consists of not only the position controlling A, B and Z phase signals but also a counter designed to detect a position within one revolution and a cumulative revolution counter designed to detect the number of revolutions.

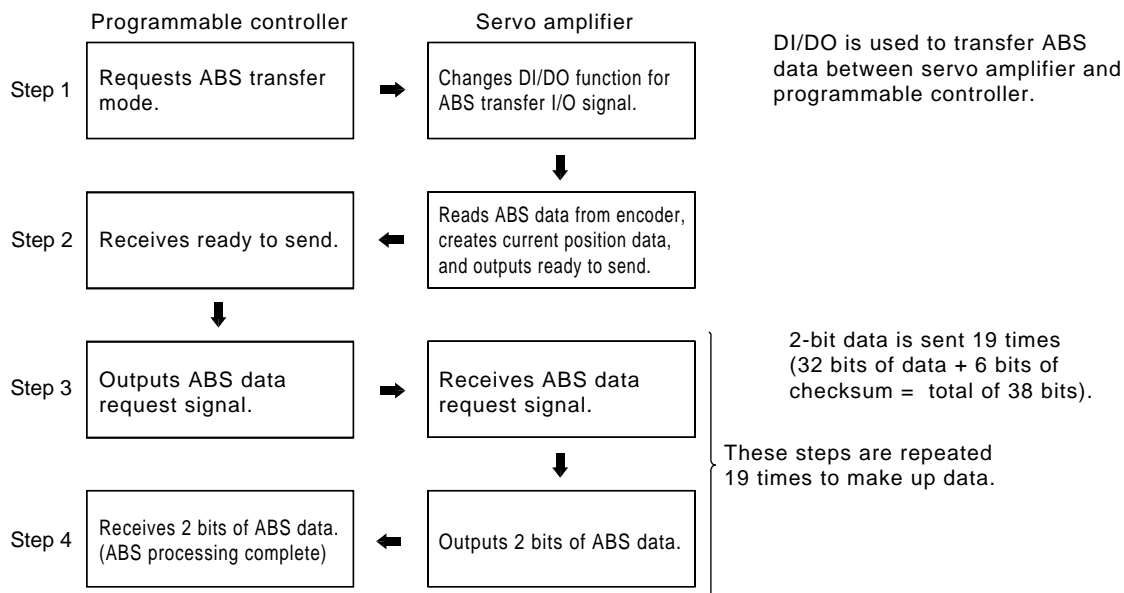
Whether the general-purpose programmable controller power is on or off, the absolute position detection system keeps the absolute position of the machine detected and battery-backed. Therefore, once the home position has been set during machine installation, dog type zeroing is not needed thereafter at power-on, ensuring ease of recovery after a power failure or fault.

Also, battery-backed by the super capacitor in the encoder, absolute position data can be held if cable disconnection or cable breakage occurs within the specified time (data holding time during battery replacement).



## 5.ABSOLUTE POSITION DETECTION SYSTEM

### 2) Communication sequence



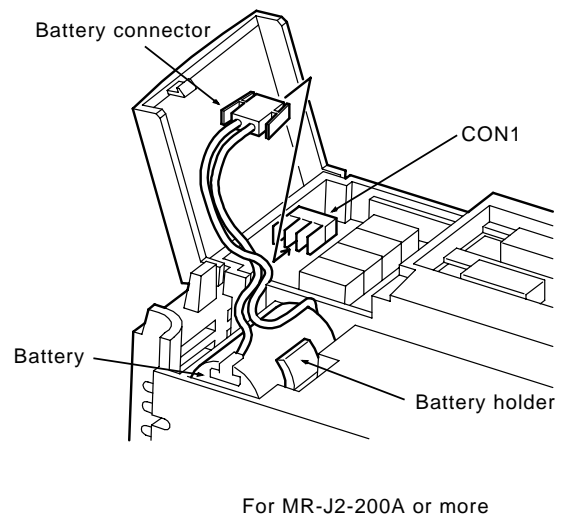
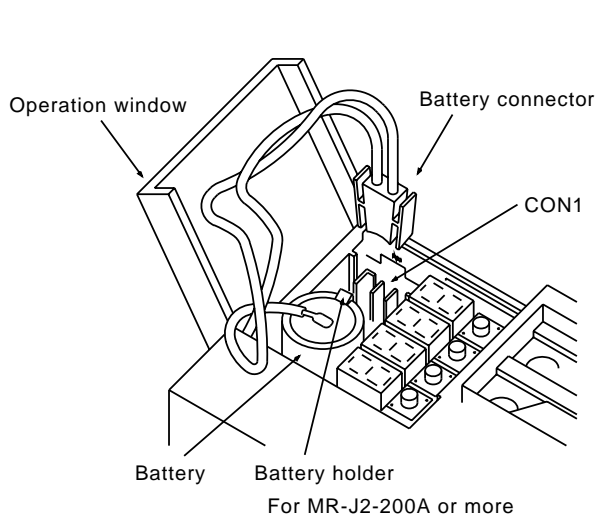
### (5) Battery installation procedure

#### NOTICE

The internal circuits of the servo amplifier may be damaged by static electricity. Always take the following precautions:

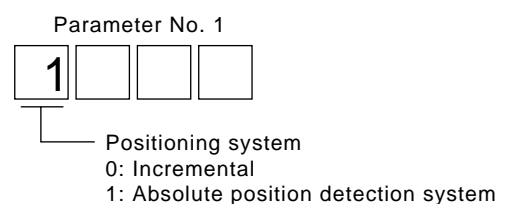
1. Ground human body and work bench.
2. Do not touch the conductive areas, such as connector pins and electrical parts, directly by hand.

- 1) Open the operation window. (When the model used is the MR-J2-200A or more, also remove the front cover.)
- 2) Install the battery in the battery holder.
- 3) Insert the battery connector into CON1 until it clicks.



### (6) Parameter setting

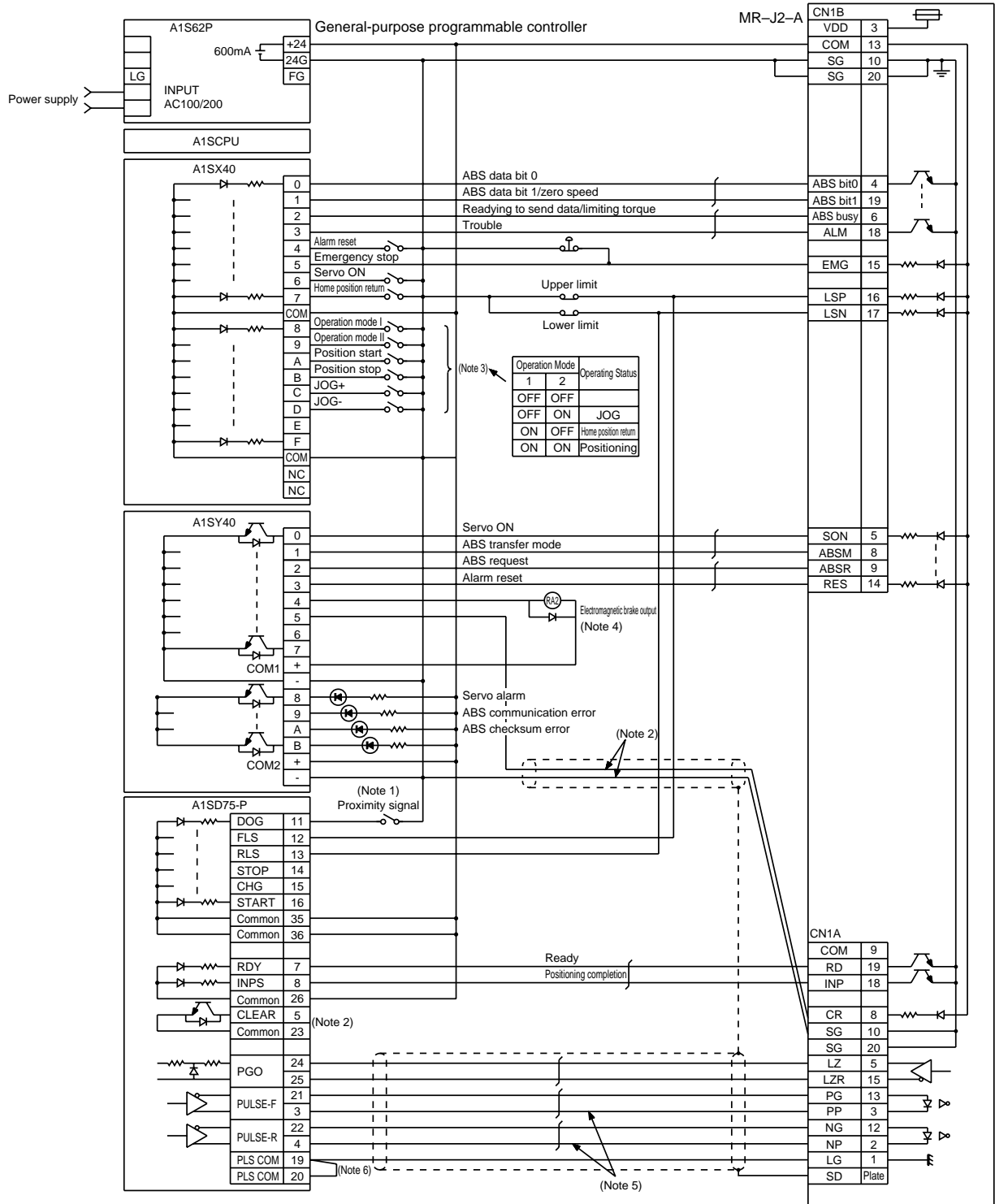
Set 1    in parameter No. 1 to make the absolute position detection system valid.



# 5.ABSOLUTE POSITION DETECTION SYSTEM

## (7) Connection example

This diagram shows connection between the MELSEC-A1SD75 (AD75) and servo amplifier.



For notes, refer to page 5-6.



## 5.ABSOLUTE POSITION DETECTION SYSTEM

---

- Note:
1. For dog type home position return. Do not connect when home position return is of the data set type.
  2. If the servo motor provided with the zero point signal is started, the A1SD75 (AD75) will output the deviation counter clear signal. Therefore, do not connect the clear signal of the MR-J2-A to the A1SD75 (AD75) but connect it to the output module of the programmable controller.
  3. This circuit is for your reference.
  4. The electromagnetic brake output should be controlled via a relay connected to the programmable controller output.
  5. Use the differential line driver system for pulse input. Do not use the open collector system.
  6. To reinforce noise suppression, connect LG and pulse output COM.

# CHAPTER 6

## OPTIONS AND AUXILIARY EQUIPMENT

---

This chapter offers how to use various options and auxiliary equipment.

- 6-1 Dedicated options
  - 6-1-1 Regenerative brake options
  - 6-1-2 Cable connectors
  - 6-1-3 Junction terminal block
  - 6-1-4 Maintenance junction card
  - 6-1-5 Set-up software
- 6-2 Auxiliary equipment
  - 6-2-1 Cables
  - 6-2-2 No-fuse breakers, fuses, magnetic contactors
  - 6-2-3 Power factor improving reactors
  - 6-2-4 Relays
  - 6-2-5 Surge absorbers
  - 6-2-6 Noise reduction techniques
  - 6-2-7 Leakage current breaker
  - 6-2-8 Battery (MR-BAT, A6BAT)
  - 6-2-9 Setting potentiometers for analog inputs

<b>INTRODUCTION</b>	<b>CHAPTER 1</b>
<b>OPERATION</b>	<b>CHAPTER 2</b>
<b>WIRING</b>	<b>CHAPTER 3</b>
<b>INSTALLATION</b>	<b>CHAPTER 4</b>
<b>ABSOLUTE POSITION DETECTION SYSTEM</b>	<b>CHAPTER 5</b>
<b>OPTIONS AND AUXILIARY EQUIPMENT</b>	<b>CHAPTER 6</b>
<b>INSPECTION</b>	<b>CHAPTER 7</b>
<b>TROUBLESHOOTING</b>	<b>CHAPTER 8</b>
<b>CHARACTERISTICS</b>	<b>CHAPTER 9</b>
<b>SPECIFICATIONS</b>	<b>CHAPTER 10</b>
<b>SELECTION</b>	<b>CHAPTER 11</b>

## 6. OPTIONS AND AUXILIARY EQUIPMENT

### WARNING

Before connecting any option or auxiliary equipment, make sure that the charge lamp is off more than 10 minutes after power-off, then confirm the voltage with a tester or the like. Otherwise, you may get an electric shock.

### CAUTION

Use the specified auxiliary equipment and options. Unspecified ones may lead to a fault or fire.

### 6-1 Dedicated options

#### 6-1-1 Regenerative brake options

### CAUTION

The specified combinations of regenerative brake options and servo amplifiers may only be used. Otherwise, a fire may occur.

#### (1) Combination and regenerative power

Servo Amplifier Model	(Note) Regenerative Power[W]					
	Built-in regenerative brake resistor	MR-RB032 [40Ω]	MR-RB12 [40Ω]	MR-RB32 [40Ω]	MR-RB30 [13Ω]	MR-RB50 [13Ω]
MR-J2-10A(1)	Without	30				
MR-J2-20A(1)	10	30	100			
MR-J2-40A(1)	10	30	100			
MR-J2-60A	10	30	100			
MR-J2-70A	20	30	100	300		
MR-J2-100A	20	30	100	300		
MR-J2-200A	100				300	500
MR-J2-350A	100				300	500

Note: These values indicate the regenerative powers caused by the resistor, not the rated powers.

#### (2) Selection of the regenerative brake option

##### 1) Simple selection method

In horizontal motion applications, select the regenerative brake option as described below: When the servo motor is run without load in the regenerative mode from the running speed to a stop, the permissible duty is as indicated in the standard specifications (Section 10-1). For the servo motor with a load, the permissible duty changes according to the inertia moment of the load and can be calculated by the following formula:

$$\text{Permissible duty} = \frac{\text{permissible duty for servo motor with no load (value indicated in Section 10-1)}}{(m+1)} \times \left( \frac{\text{rated speed}}{\text{running speed}} \right)^2 [\text{times/minute}]$$

where m = load inertia moment/servo motor inertia moment

From the permissible duty, find whether the regenerative brake option is required or not.

Permissible duty < number of positioning times n1 [times/minute]

Select the regenerative brake option out of the combinations in (1) in this section.

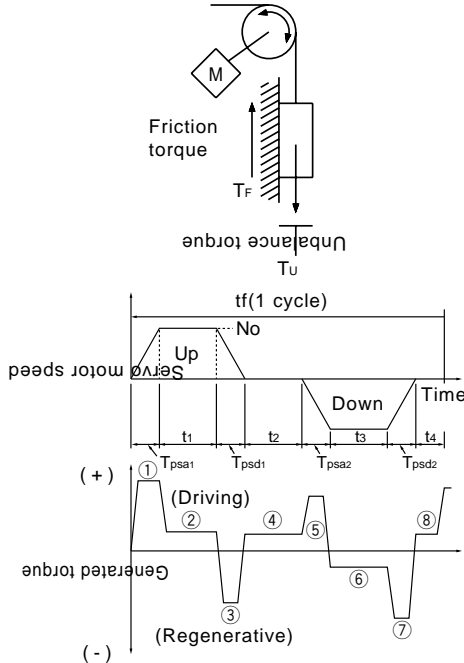
## 6. OPTIONS AND AUXILIARY EQUIPMENT

2) To make selection according to regenerative energy

Use the following method when regeneration occurs continuously in vertical motion applications or when it is desired to make an in-depth selection of the regenerative brake option:

a. Regenerative energy calculation

Use the following table to calculate the regenerative energy.



Formulas for Calculating Torque and Energy in Operation

Regenerative Power	Torque applied to servo motor [N • m]	Energy [J]
1)	$T_1 = \frac{(J_L + J_M) \cdot N_o}{9.55 \times 10^4} \cdot \frac{1}{T_{Psa1}} + T_U + T_F$	$E_1 = \frac{0.1047}{2} \cdot N_o \cdot T_1 \cdot T_{Psa1}$
2)	$T_2 = T_U + T_F$	$E_2 = 0.1047 \cdot N_o \cdot T_2 \cdot t_1$
3)	$T_3 = \frac{(J_L + J_M) \cdot N_o}{9.55 \times 10^4} \cdot \frac{1}{T_{Psd1}} + T_U + T_F$	$E_3 = \frac{0.1047}{2} \cdot N_o \cdot T_3 \cdot T_{Psd1}$
4), 8)	$T_4 = T_U$	$E_4 \geq 0$ (Not regenerative)
5)	$T_5 = \frac{(J_L + J_M) \cdot N_o}{9.55 \times 10^4} \cdot \frac{1}{T_{Psa2}} - T_U + T_F$	$E_5 = \frac{0.1047}{2} \cdot N_o \cdot T_5 \cdot T_{Psa2}$
6)	$T_6 = T_U + T_F$	$E_6 = 0.1047 \cdot N_o \cdot T_6 \cdot t_3$
7)	$T_7 = \frac{(J_L + J_M) \cdot N_o}{9.55 \times 10^4} \cdot \frac{1}{T_{Psd2}} - T_U + T_F$	$E_7 = \frac{0.1047}{2} \cdot N_o \cdot T_7 \cdot T_{Psd2}$
Sum total of regenerative energies		Sum total of negative energies in 1) to 8)

b. Losses of servo motor and servo amplifier in regenerative mode

The following table lists the efficiencies and other data of the servo motor and servo amplifier in the regenerative mode.

Servo Amplifier	Inverse Efficiency[%]	Capacitor Charging[J]
MR-J2-10A(1)	55	9
MR-J2-20A(1)	70	9
MR-J2-40A(1)	85	11
MR-J2-60A	85	11
MR-J2-70A	80	18
MR-J2-100A	80	18
MR-J2-200A	85	40
MR-J2-350A	85	40

Inverse efficiency ( $\eta$ ) : Efficiency including some efficiencies of the servo motor and servo amplifier when rated (regenerative) torque is generated at rated speed. Since the efficiency varies with the speed and generated torque, allow for about 10%.

Capacitor charging ( $E_c$ ) : Energy charged into the electrolytic capacitor in the servo amplifier. Subtract the capacitor charging from the result of multiplying the sum total of regenerative energies by the inverse efficiency to calculate the energy consumed by the regenerative brake option.

$$E_R \text{ [J]} = \eta \cdot E_s - E_c$$

Calculate the power consumption of the regenerative brake option on the basis of single-cycle operation period  $t_f$  [s] to select the necessary regenerative brake option.

$$P_R \text{ [W]} = E_R / t_f \dots\dots\dots (6-1)$$

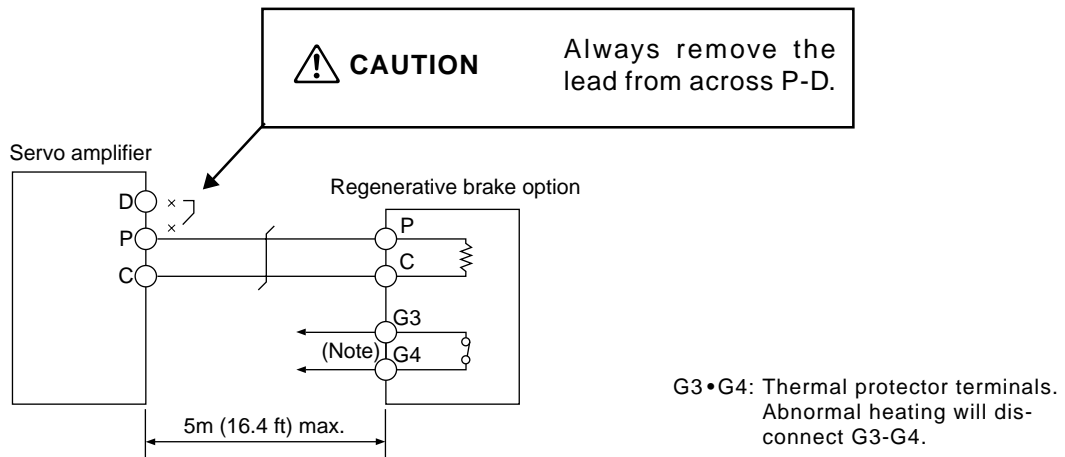
## 6. OPTIONS AND AUXILIARY EQUIPMENT

### (3) Connection of the regenerative brake option

When using the regenerative brake option, always remove wiring from across P-D and install the regenerative brake option across P-C. Set parameter No.0 according to the option to be used. The regenerative brake option will generate heat of about 100°C. Fully examine heat dissipation, installation position, used cables, etc. before installing the option. For wiring, use fire-retarding cables and keep them clear of the regenerative brake option body. Always use twisted cables of max. 5m length for connection with the servo amplifier.

Parameter No. 0

Selection of regenerative brake option  
 0: Not used.  
 2: MR – RB 032  
 3: MR – RB 12  
 4: MR – RB 32  
 5: MR – RB 30  
 6: MR – RB 50

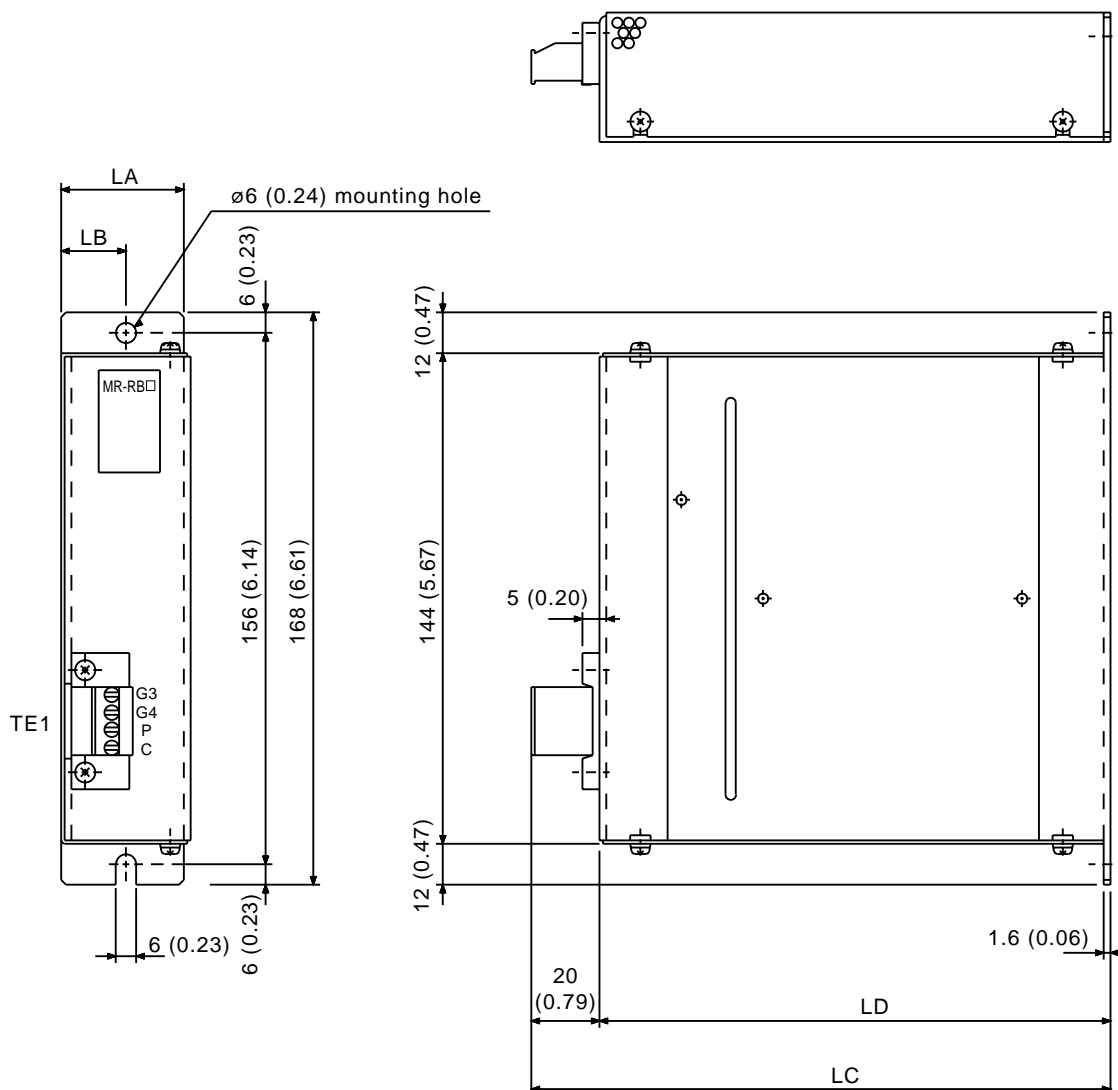


Note: Make up a sequence which will switch off the magnetic contactor (MC) when abnormal heating occurs.

## 6. OPTIONS AND AUXILIARY EQUIPMENT

- (4) Outline drawing  
 1) MR-RB032•MR-RB12

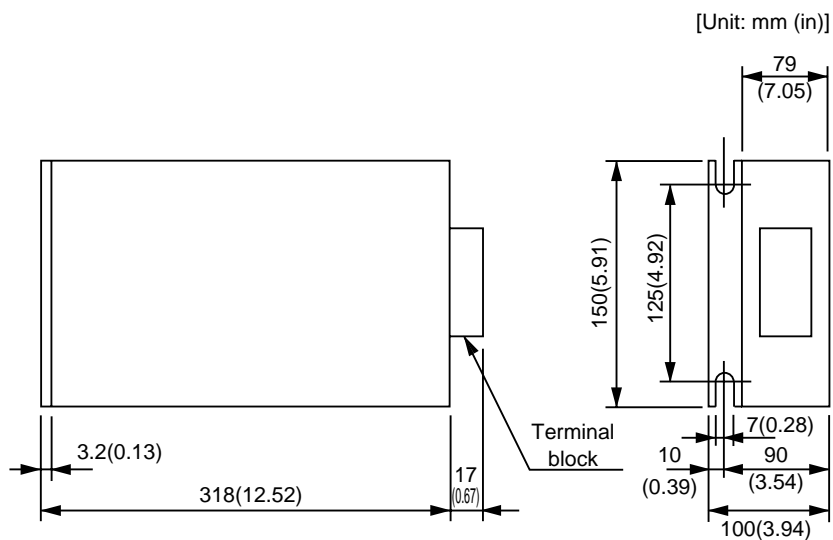
[Unit: mm (in)]



Regenerative Brake Option	Regenerative Power[W]	Resistance [Ω]	Variable Dimensions				Weight	
			LA	LB	LC	LD	[kg]	[lb]
MR – RB032	30	40	30 (1.18)	15 (0.59)	119 (4.69)	99 (3.9)	0.5	1.1
MR – RB12	100	40	40 (1.57)	15 (0.59)	169 (6.65)	149 (5.87)	1.1	2.4

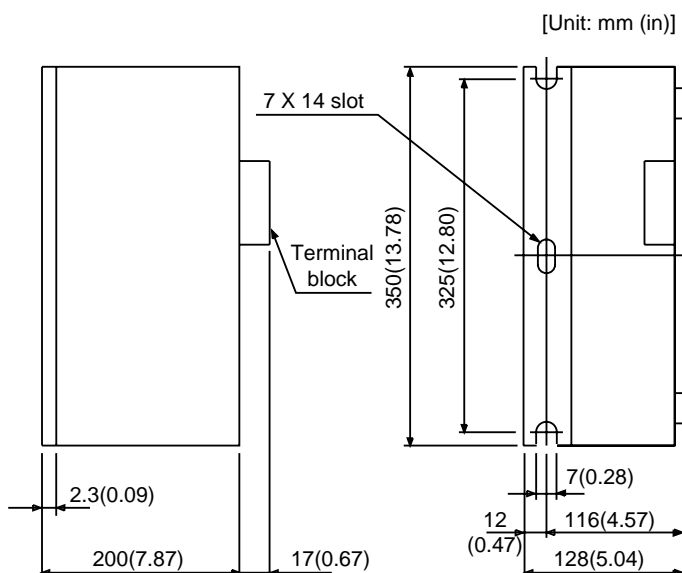
## 6. OPTIONS AND AUXILIARY EQUIPMENT

### 2) MR-RB32•MR-RB30



Regenerative Brake Option	Regenerative Power [W]	Resistance [ $\Omega$ ]	Weight	
			[kg]	[lb]
MR-RB32	300	40	2.9	6.4
MR-RB30	300	13	2.9	6.4

### 3) MR-RB50



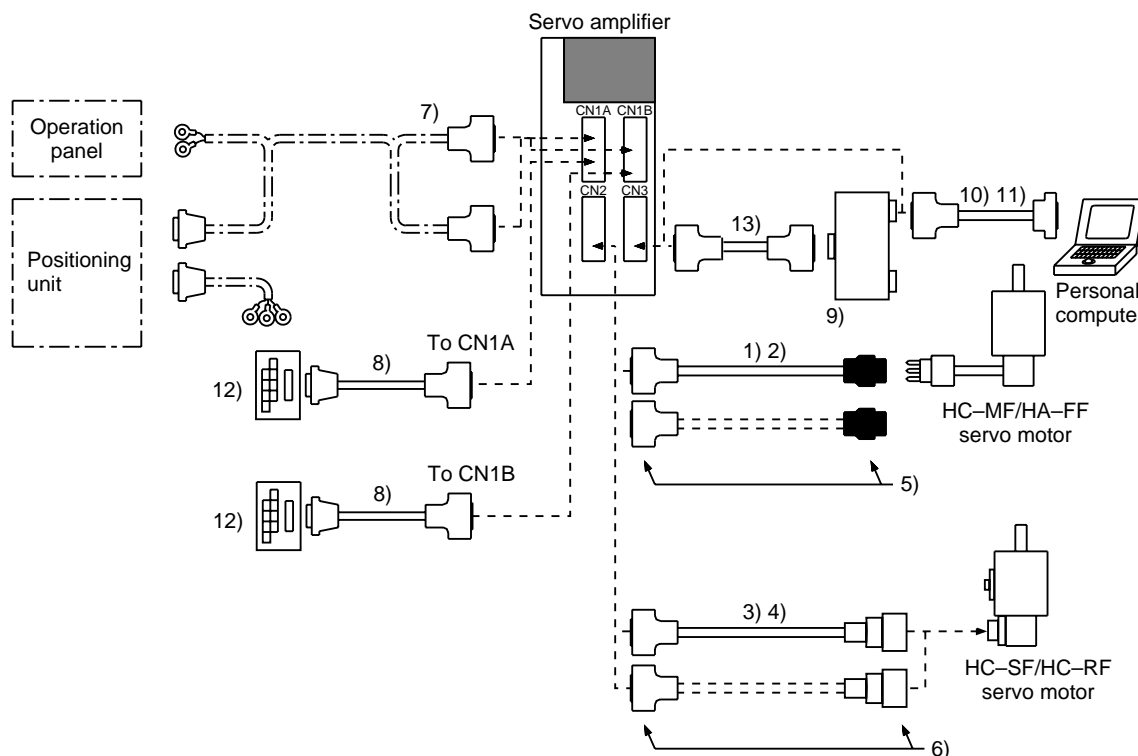
Regenerative Brake Option	Regenerative Power [W]	Resistance [ $\Omega$ ]	Weight	
			[kg]	[lb]
MR-RB50	500	13	5.6	12.3

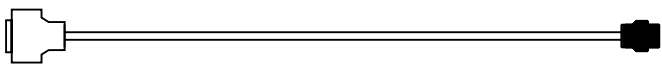
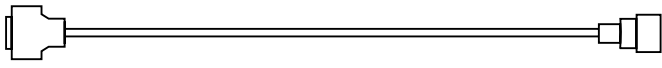
# 6. OPTIONS AND AUXILIARY EQUIPMENT

## 6-1-2 Cable connectors

### (1) Cable selection






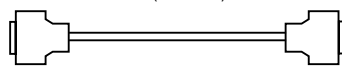
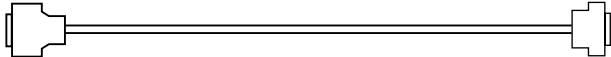
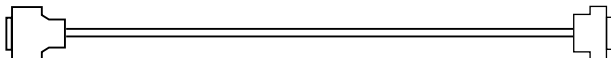
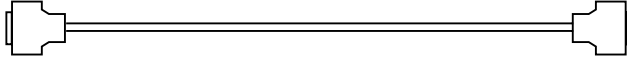
- Use the encoder cable 1) or 2) or 3) or 4) after confirming the required wiring length. To fabricate the encoder cable, use the encoder connector set 5) or 6) and refer to (2) in this section.
- The control signals may either be exported directly using the control signal connector 7) or to the junction terminal block 12) via the junction terminal block cable 8). Use the options according to the connection method.
- When using the personal computer during operation, use the maintenance junction card 9) and also use the communication cable 10) or 11).
- For the outline drawing of each connector, refer to Section 10-5-4.



Product		Model	Description	
For CN2	1) Standard encoder cable for HC-MF/HA-FF HC-UF 3000r/min	MR-JCCBL□M-L Cable length in □ : 2, 5, 10, 20, 30[m]	Servo amplifier side connector (3M or equivalent) 10120-3000VE (Connector) 10320-52F0-008 (Shell kit)	Servo motor encoder side connector (AMP) 1-172161-9 (Connector)
	2) Long flexing-life encoder cable for HC-MF/HA-FF HC-UF 3000r/min	MR-JCCBL□M-H Cable length in □ : 2, 5, 10, 20, 30, 40, 50[m]		
	3) Standard encoder cable for HC-SF/HC-RF HC-UF 2000r/min	MR-JHSCBL□M-L Cable length in □ : 2, 5, 10, 20, 30, 40, 50[m]	Servo amplifier side connector (3M or equivalent) 10120-3000VE (Connector) 10320-52F0-008 (Shell kit)	Servo motor encoder side connector (Japan Aviation Electronics) MS3106B20-29S (Straight plug) MS-3057-12A (Cable clamp)
	4) Long flexing-life encoder cable for HC-SF/HC-RF HC-UF 2000r/min	MR-JHSCBL□M-H Cable length in □ : 2, 5, 10, 20, 30, 40, 50[m]		



## 6. OPTIONS AND AUXILIARY EQUIPMENT

Product		Model	Description	
For CN2	5) Encoder connector set for HC-MF/HA-FF	MR-J2CNM	Servo amplifier side connector (3M or equivalent) 0120-3000VE (Connector) 10320-52F0-008 (Shell kit) 	Servo motor encoder side connector (AMP) 1-172161-9 (Housing) 170359-1 (Connector pin) MTI-0002 (Clamp) 
	6) Encoder connector set for HC-SF	MR-J2CNS	Servo amplifier side connector (3M or equivalent) 10120-3000VE (Connector) 10320-52F0-008 (Shell kit) 	Servo motor encoder side connector (Japan Aviation Electronics) MS3106B20-29S (Straight plug) MS-3057-12A (Cable clamp) 
For CN1A, CN1B	7) Control signal connector	MR-J2CN1	Servo amplifier side connector (3M or equivalent) 10120-3000VE (Connector) 10320-52F0-008 (Shell kit) 	Qty: 2 each
	8) Junction terminal block cable	MR-J2TBL□M Length: 0.5[m]	Servo amplifier side connector (3M or equivalent) 10120-6000EL (Connector) 10320-3210-000 (Shell kit) 	Junction terminal block side connector HIF3BA-20D-2.54R (Hirose Electric)
For CN3	9) Maintenance junction card	MR-J2CN3TM	Refer to Section 6-1-4.	
	10) Communication cable for PC98	MR-CPC98CBL3M Cable length: 3[m]	Servo amplifier side connector (3M or equivalent) 10120-6000EL (Connector) 10320-3210-000 (Shell kit) 	PC98 series personal computer side connector (Japan Aviation Electronics) Connector: DE-25PF-N Case: DB-C2-J9
	11) Communication cable for DOS/V	MR-CPCATCBL3M Cable length: 3[m]	Servo amplifier side connector (3M or equivalent) 10120-6000EL (Connector) 10320-3210-000 (Shell kit) 	DOS/V personal computer side connector (Japan Aviation Electronics) Connector: DE-9SF-N Case: DE-C1-J6-S6
	12) Junction terminal block	MR-TB20	Refer to Section 6-1-3.	
	13) Bus cable	MR-J2HBUS□M Cable length in □ :0.5, 1, 5[m]	10120-6000EL (Connector) 10320-3210-000 (Shell kit) 	10120-6000EL (Connector) 10320-3210-000 (Shell kit)

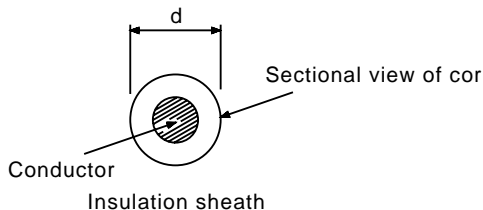
## 6. OPTIONS AND AUXILIARY EQUIPMENT

### (2) Standard encoder cable

The specifications and connection of each cable are indicated below. A fabricated cable should be as specified in the following table or equivalent and connected correctly.

Core Size [mm <sup>2</sup> ] x Pair	Core Insulation Sheath OD (Note) d [mm]	Recommended Cable Model	Cable Type
0.08 x 7	0.9 to 1.27	UL20276 AWG28 7pair (BLACK)	Standard encoder cable Communication cable
0.08 x 10		UL20276 AWG28 10pair (BLACK)	Bus cable
0.2 x 7		UL20276 AWG24 7pair (BLACK)	Standard encoder cable
0.3 x 7		UL20276 AWG22 7pair (BLACK)	Standard encoder cable

Note: d is as shown below.

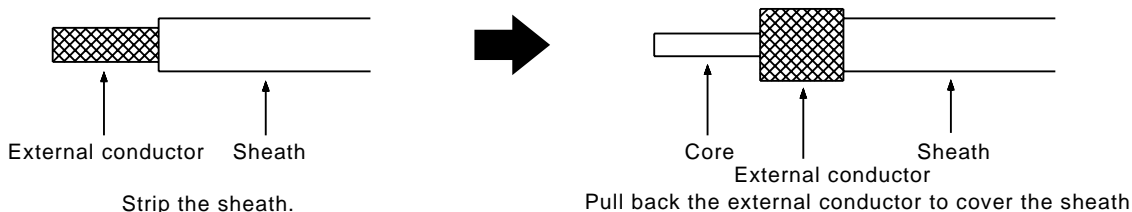


Core Size [mm <sup>2</sup> ] x Pair	Characteristics of One Core		Recommended Cable Model	Cable Type
	Structure [pcs./mm]	Conductor resistance[Ω/km]		
0.2 x 6	40/0.08	105 max.	(Note) A14B2343	Flexing, long-life encoder cable

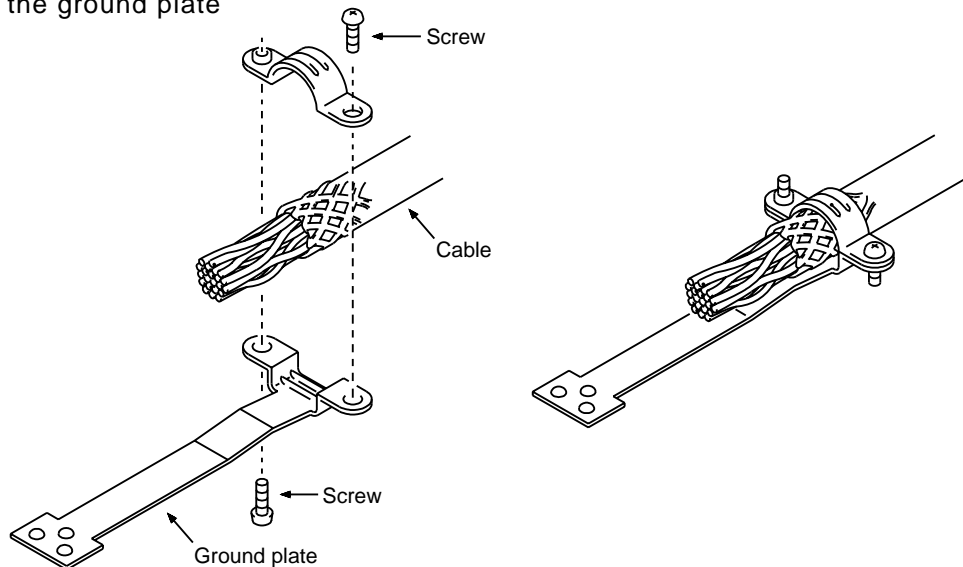
Note: Junkosha make, purchased from Toa Electric

For the control signal connector, connect the external conductor of the shielded cable to the ground plate securely as shown below.

#### a. Termination of external conductor



#### b. Fitting of the ground plate



# 6. OPTIONS AND AUXILIARY EQUIPMENT

## 1) Encoder cable connection diagrams

**CAUTION**

If you have fabricated the encoder cable, connect it correctly. Otherwise, misoperation or explosion may occur.

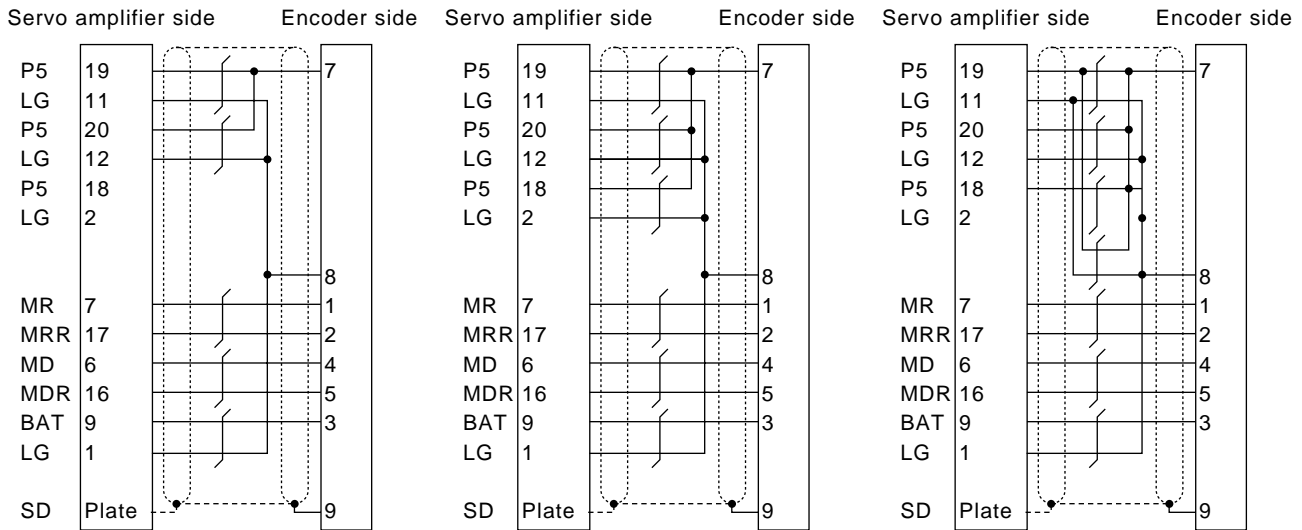
a. For HC-MF/HA-FF

**Optional cables**

MR-JCCBL2M-L  
MR-JCCBL5M-L  
MR-JCCBL2M-H  
MR-JCCBL5M-H

MR-JCCBL10M-L  
to  
MR-JCCBL30M-L

MR-JCCBL10M-H  
to  
MR-JCCBL50M-H

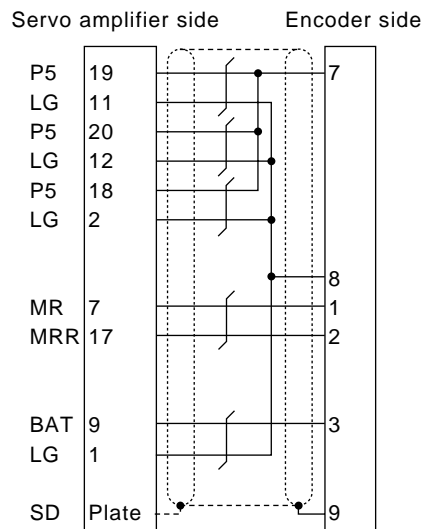
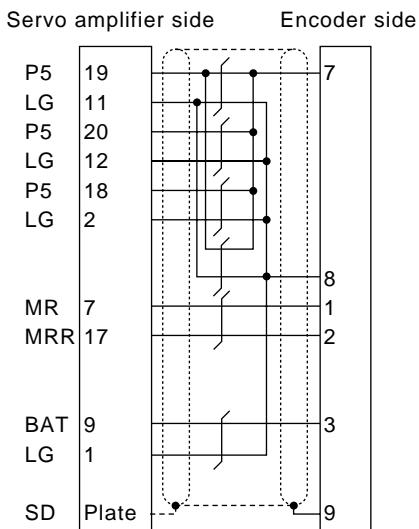


**For fabrication**

When fabricating an encoder cable, fabricate it as shown below. The cable of max. 50m length may be fabricated. When the user manufactures the detector cable, there is no need to connect "MD" and "MDR" signals.

For use of AWG24

For use of AWG22



## 6. OPTIONS AND AUXILIARY EQUIPMENT

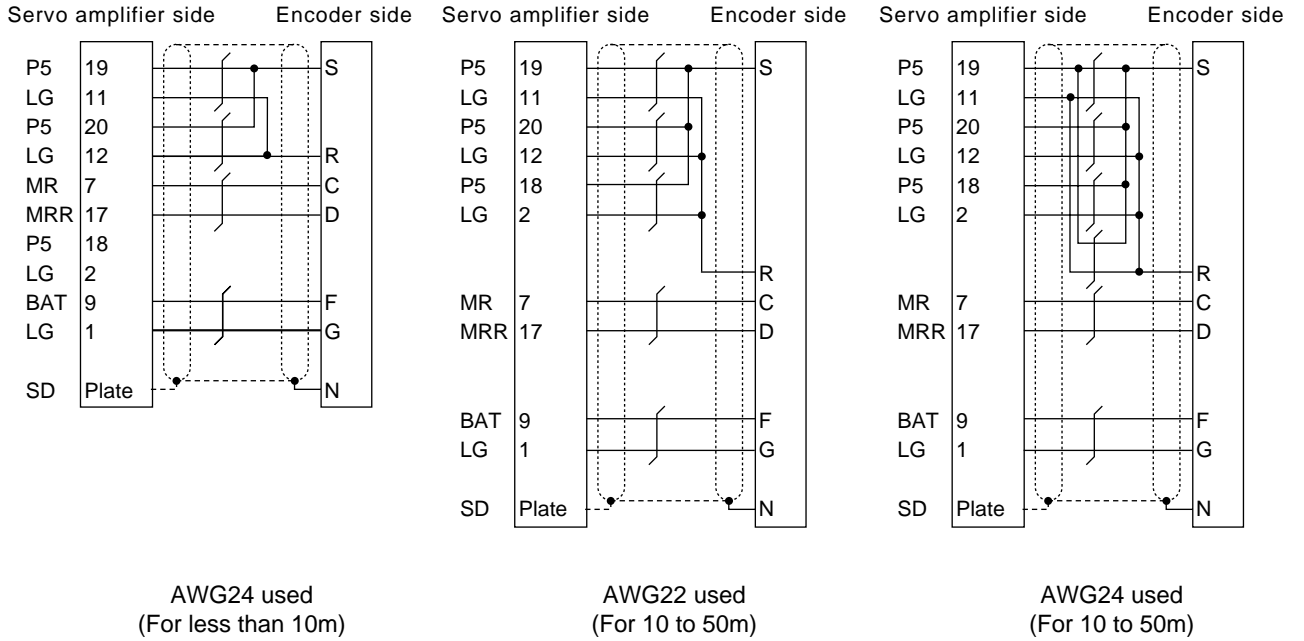
b. For HC-SF/HC-RF

When fabricating an encoder cable, fabricate it as shown below:

MR – JHSCBL2M – L  
 MR – JHSCBL5M – L  
 MR – JHSCBL2M – H  
 MR – JHSCBL5M – H

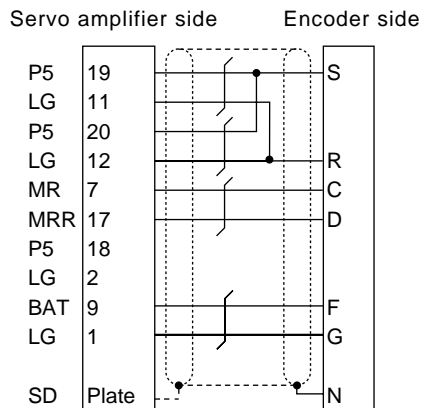
MR – JHSCBL10M – L  
 to  
 MR – JHSCBL50M – L

MR – JHSCBL10M – H  
 to  
 MR – JHSCBL50M – H



In addition to the above, the customer may also fabricate the cable of the following length:

For use of AWG28 (5m or less)



## 6. OPTIONS AND AUXILIARY EQUIPMENT

### 2) Junction terminal block cable

MR-J2TBL□M

Symbol	Cable Length [m (inch)]
0.5	0.5 (19.68)
1	1 (39.37)

Junction terminal block side

Servo amplifier side

(CN1A, CN1B side)

(Note) Abbreviated Signal Code						Junction Terminal Block Terminal No.	Pin No.		Pin No.
Position Control Mode		Speed Control Mode		Torque Control Mode					
LG	LG	LG	LG	LG	LG	10	B1		1
NP	VC		VC		VLA	0	A1		2
PP	VDD		VDD		VDD	11	B2		3
P15R	DO1	P15R	DO1	P15R	DO1	1	A2		4
LZ	SON	LZ	SON	LZ	SON	12	B3		5
LA	TLC	LA	TLC	LA	VLC	2	A3		6
LB		LB	SP2	LB	SP2	13	B4		7
CR	PC	SP1	ST1	SP1	RS2	3	A4		8
COM	TLC	COM	ST2	COM	RS1	14	B5		9
SG	SG	SG	SG	SG	SG	4	A5		10
OPC	P15R		P15R		P15R	15	B6		11
NG	TLA		TLA		TC	5	A6		12
PG	COM		COM		COM	16	B7		13
OP	RES	OP	RES	OP	RES	6	A7		14
LZR	EMG	LZR	EMG	LZR	EMG	17	B8		15
LAR	LSP	LAR	LSP	LAR		7	A8		16
LBR	LSN	LBR	LSN	LBR		18	B9		17
INP	ALM	SA	ALM		ALM	8	A9		18
RD	ZSP	RD	ZSP	RD	ZSP	19	B10		19
SD	SD	SD	SD	SD	SD	9	A10		20
									Plate

Note: The label furnished with the relay terminal block is for position control mode. When using the relay terminal block in the speed control mode or torque control mode, use the furnished signal seal to change the abbreviated signal code.

### 3) Bus cable

MR - J2HBUS05M

MR - J2HBUS1M

MR - J2HBUS5M

Servo amplifier side  
connector

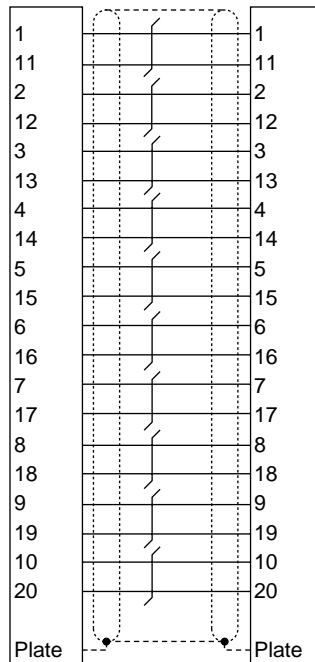
Servo amplifier side  
connector

10120-6000EL (Connector)

10120-6000EL (Connector)

10320-3210-000 (Shell kit)

10320-3210-000 (Shell kit)



## 6. OPTIONS AND AUXILIARY EQUIPMENT

### 4) Communication cable

#### NOTICE

This cable may not be used with some personal computers. After fully examining the signals of the RS-232C connector, refer to this section and fabricate the cable.

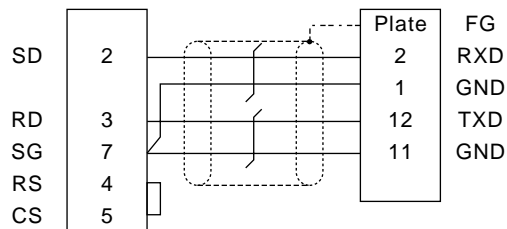
Select the communication cable according to the shape of the RS-232C connector of the personal computer used. When fabricating the cable, refer to the connection diagram in this section. The following must be observed in fabrication:

- Always use a shielded, multi-core cable and connect the shield with FG securely.
- The optional communication cable is 3m (10 ft) long. When the cable is fabricated, its maximum length is 15m (49 ft) in offices of good environment with minimal noise.

#### Connection diagram

##### • MR-CPC98CBL3M

Personal computer side      Servo amplifier side

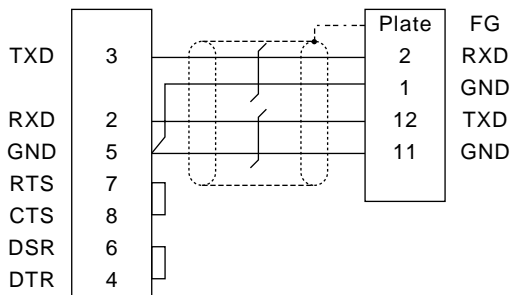


D-SUB25 pins  
(Note)

Half-pitch 20 pins

##### • MR-CPCATCBL3M

Personal computer side      Servo amplifier side



D-SUB9 pins

Half-pitch 20 pins

Note: The PC98 Notes having the connector of half-pitch 14 pins are also available. Confirm the shape of the RS-232C connector of the personal computer used.

## 6. OPTIONS AND AUXILIARY EQUIPMENT

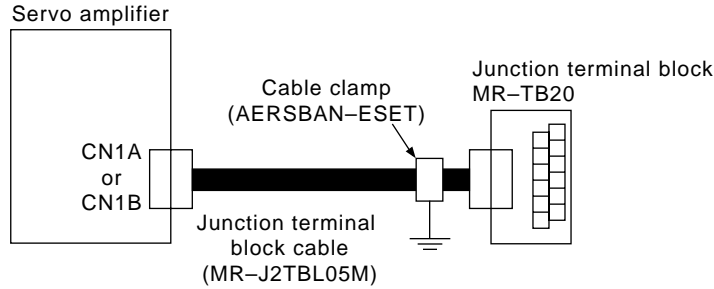
### 6-1-3 Junction terminal block

**POINT**

When using the relay terminal, "SG" of CN1A-20 and CN1B-20 cannot be used. Use "SG" of CN1A-4 and CN1B-4.

(1) How to use the junction terminal block

Always use the junction terminal block (MR-TB20) with the junction terminal block cable (MR-J2TBL05M) as a set. A connection example is shown below:



Ground the junction terminal block cable on the junction terminal block side with the standard accessory cable clamp fitting (AERSBAN-ESET). For the use of the cable clamp fitting, refer to (3), Section 6-2-6.

(2) Terminal labels

The junction terminal block has three terminal block labels which indicate signal arrangement. Out of these labels, use the two for MR-J2-A. These two labels are for use in the position control mode. When the parameter settings of I/O signals have been changed or the position control mode is switched to the speed or torque control mode, refer to (2) in Section 6-1-2 or (2) in Section 3-1-2 and apply the accessory signal seals to the labels.

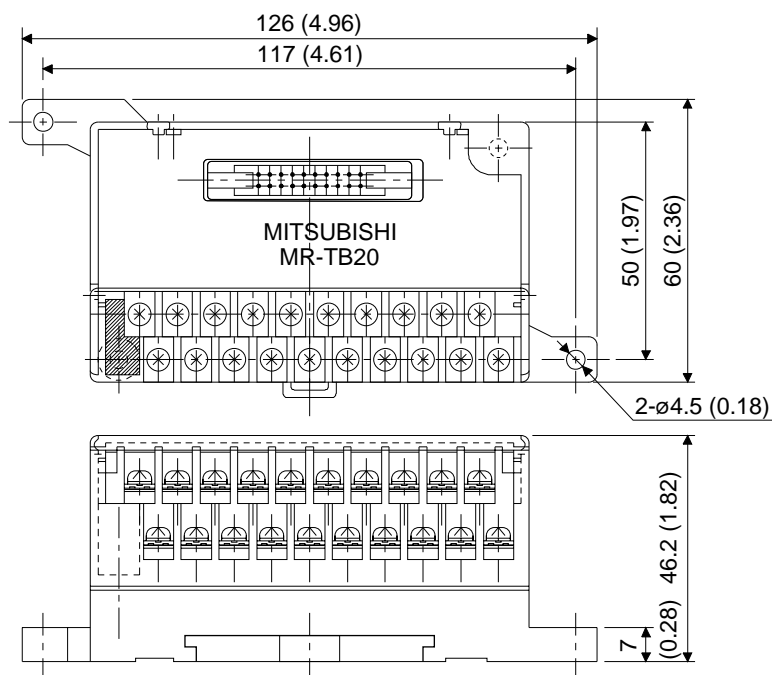
1) For CN1A

10	LG	11	PP	12	LZ	13	LB	14	COM	15	OPC	16	PG	17	LZR	18	LBR	19	RD
0	NP	1	P15R	2	LA	3	CR	4	SG	5	NG	6	OP	7	LAR	8	INP	9	SD

2) For CN1B

10	LG	11	VDD	12	SON	13	TL	14	P15R	15	COM	16	EMG	17	LSN	18	ZSP	19	
0	VC	1	DO1	2	TLC	3	PC	4	SG	5	TLA	6	RES	7	LSP	8	ALM	9	SD

(3) Outline drawing



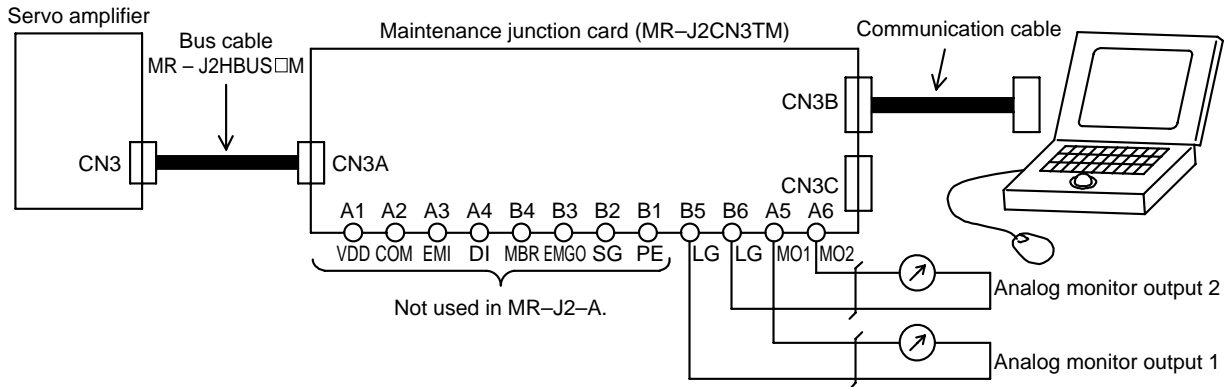
[Unit: mm]  
[Unit: in.]

# 6. OPTIONS AND AUXILIARY EQUIPMENT

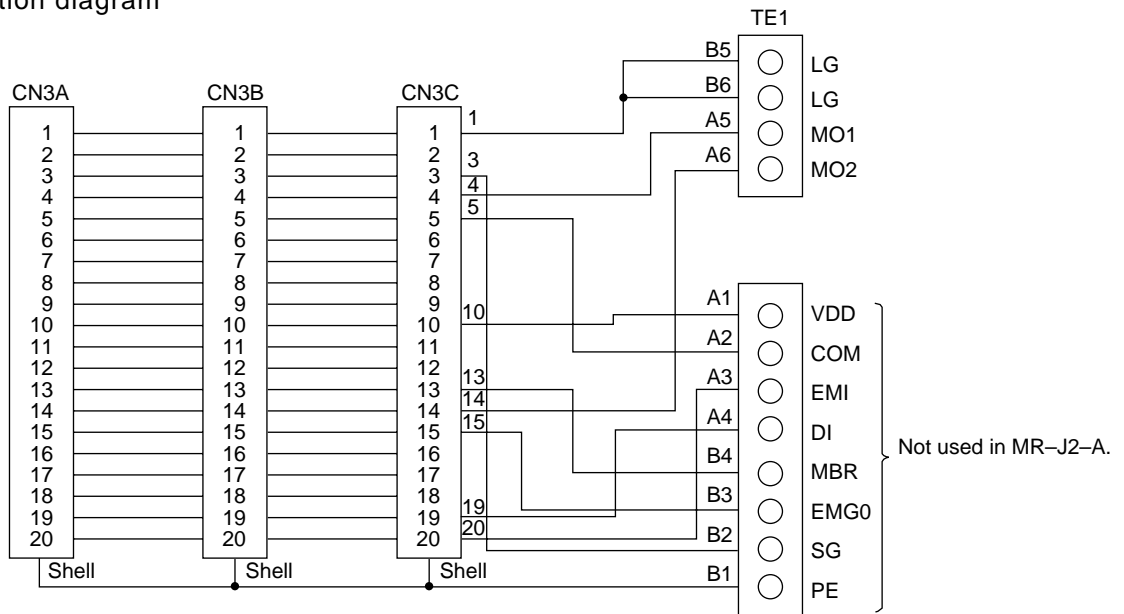
## 6-1-4 Maintenance junction card

### (1) Usage

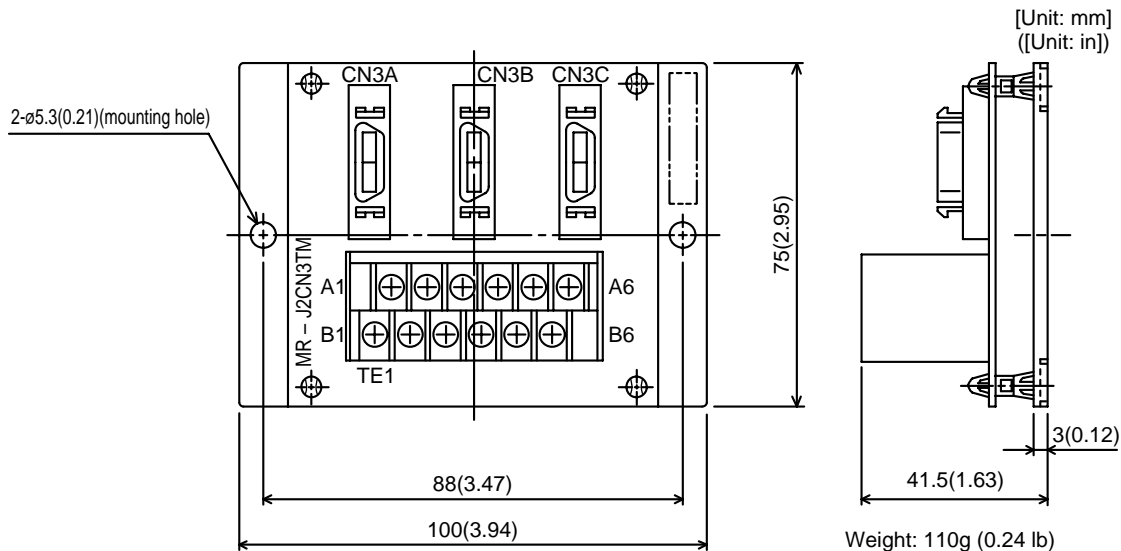
The maintenance junction card (MR-J2CN3TM) is designed for use when a personal computer and analog monitor outputs are used at the same time.



### (2) Connection diagram



### (3) Outline drawing





## 6. OPTIONS AND AUXILIARY EQUIPMENT

### 6-1-5 Set-up software (will be released soon)

<b>NOTICE</b>	Some functions of the setup software may not be used depending on versions. For details, contact us.
---------------	---

The setup software (MRZJW3-SETUP31E or later) uses the communication function of the servo amplifier to perform parameter setting changes, graph display, test operation, etc. on a personal computer.

#### (1) Specifications

Item	Description
Communication signal	Conforms to RS-232C.
Baudrate	19200bps, 9600bps
Monitor	Batch display, high-speed display, graph display
Alarm	Alarm display, alarm history, data display at alarm occurrence (Minimum resolution changes according to the processing speed of the personal computer)
Diagnostic	External I/O signal display, no-rotation reason display, cumulative power-on time display, software number display, tuning data display, ABS data display, automatic VC offset display
Parameters	Data setting, list display, change list display, detailed information display
Test operation	Jog mode, positioning mode, motor-less operation, output signal forced output, program operation in simple language
File operation	Data read, save, print
Others	Automatic operation, help display

Note: On some personal computers, this software may not run properly.

#### (2) System configuration

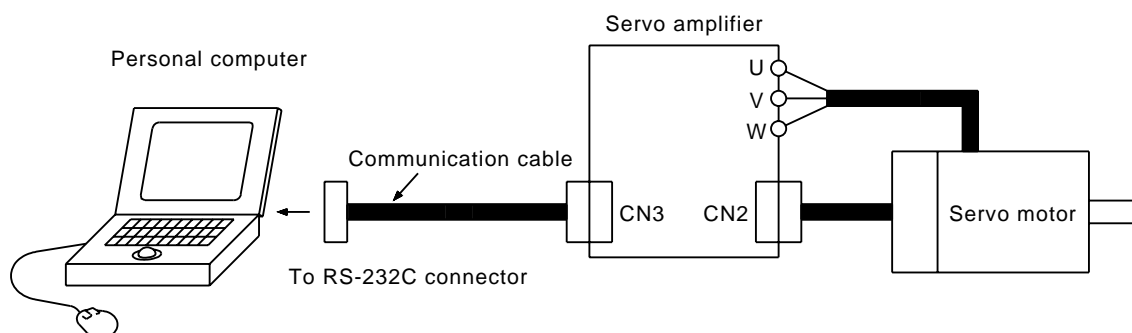
##### 1) Components

To use this software, the following components are required in addition to the servo amplifier and servo motor:

Model	Description
Personal computer	Which contains a 80386 or higher CPU and on which Windows 3.1•95 runs (80486 or higher recommended).Memory: 8MB or more, hard disk free space: 1MB or more, serial port used.
OS	Windows 3.1
Display	640 x 400 or more color or 16-scale monochrome display which can be used with Windows 3.1•95.
Keyboard	Which can be connected to the personal computer.
Mouse	Which can be used with Windows 3.1•95. Note that a serial mouse is not used.
Printer	Which can be used with Windows 3.1•95.
Communication cable	MR – CPC98CBL3M • MR – CPCATCBL3M When these cannot be used, refer to Section 6-1-2 and fabricate.

Note: Windows is a trade mark of Microsoft Corporation.

##### 2) Configuration diagram



## 6. OPTIONS AND AUXILIARY EQUIPMENT

### 6-2 Auxiliary equipment

The auxiliary equipment used must be those indicated in this section or equivalent. To comply with the EN Standard or UL/C-UL Standard, use the auxiliary equipment which conform to the corresponding standard.

#### 6-2-1 Cables

Servo Amplifier Model	(Note 1) Cables [mm <sup>2</sup> ]					(Note 3) Crimping Terminal	
	L1•L2•L3	L11 • L21	U • V • W•Ⓧ	P • C • D	B1 • B2	Model	Tool
MR – J2 – 10A(1)	2 (AWG14)	1.25 (AWG16)	1.25 (AWG16)	(Note 2) 2 (AWG14)	1.25 (AWG16)	32959	47387
MR – J2 – 20A(1)							
MR – J2 – 40A(1)							
MR – J2 – 60A							
MR – J2 – 70A							
MR – J2 – 100A	3.5(AWG12)		2(AWG14)				
MR – J2 – 200A			3.5(AWG12)				
MR – J2 – 350A			5.5(AWG10)				

- Note: 1. The cables are based on the 600V vinyl cables. The cables (U, V, W) in the table assume that the distance between the servo motor and servo amplifier is 30m or less.  
 2. Twist the cables for connection of the regenerative brake option (P, C).  
 3. Used with the UL/C-UL Standard-compliant models. (AMP make)

#### 6-2-2 No-fuse breakers, fuses, magnetic contactors

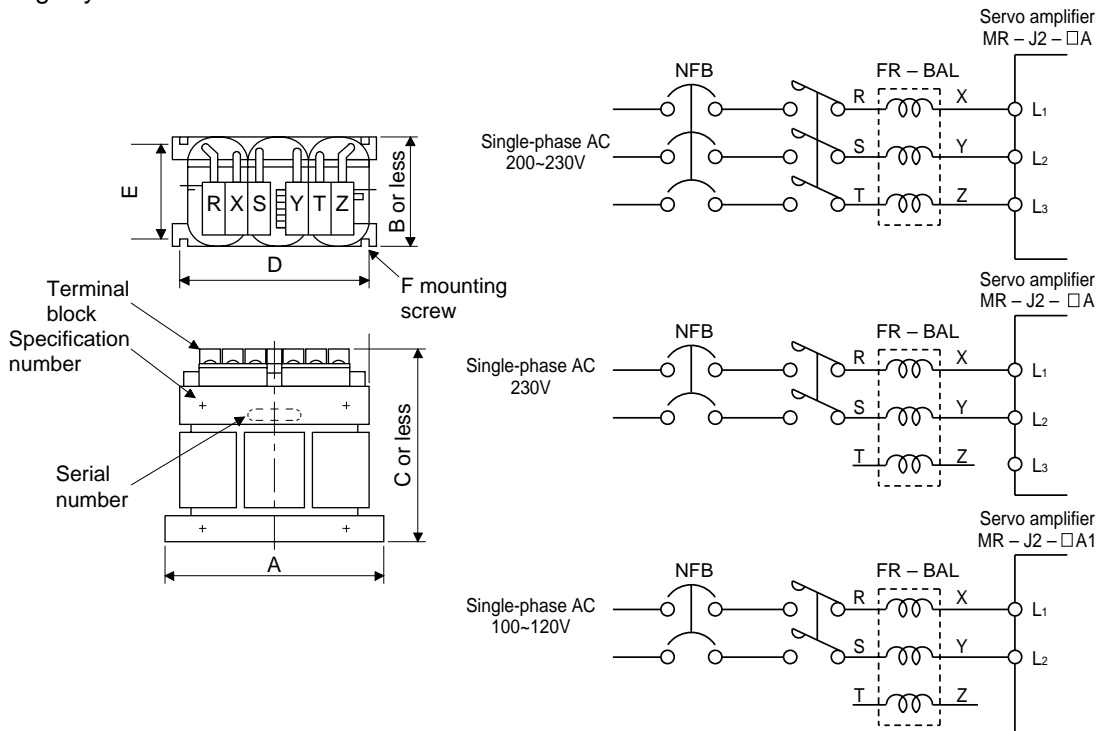
Ensure to use one circuit breaker and electromagnetic contactor for each servo amplifier. When using a fuse in place of the circuit breaker, use a fuse of the rating specified in this section.

Servo Amplifier	No-Fuse Breaker	Fuse			Magnetic Contactor
		Class	Current[A]	Voltage[V]	
MR – J2 – 10A(1)	NF30 type 5A	K5	10	AC250	S-N10
MR – J2 – 20A	NF30 type 5A	K5	10		
MR – J2 – 40A•20A1	NF30 type 10A	K5	15		
MR – J2 – 60A•40A1	NF30 type 15A	K5	20		
MR – J2 – 70A	NF30 type 15A	K5	20		
MR – J2 – 100A	NF30 type 15A	K5	25		
MR – J2 – 200A	NF30 type 20A	K5	40		S-N18
MR – J2 – 350A	NF30 type 30A	K5	70	S-N20	

## 6. OPTIONS AND AUXILIARY EQUIPMENT

### 6-2-3 Power factor improving reactors

The input power factor is improved to about 90%. For use with a single-phase power supply, it may be slightly lower than 90%.



Servo amplifier Model	Model	Dimensions [mm (in)]						Weight [kg(lb)]
		A	B	C	D	E	F	
MR-J2-10(1)•20A(1)	FR-BAL-0.4K	135 (5.31)	64 (2.25)	120 (4.72)	120 (4.72)	45 (1.77)	M4	2 (4.4)
MR-J2-40A(1)	FR-BAL-0.75K	135 (5.31)	74 (2.91)	120 (4.72)	120 (4.72)	57 (2.24)	M4	3 (6.6)
MR-J2-60A•70A	FR-BAL-1.5K	160 (6.30)	76 (2.99)	145 (5.71)	145 (5.71)	55 (2.17)	M4	4 (8.8)
MR-J2-100A	FR-BAL-2.2K	160 (6.30)	96 (3.78)	145 (5.71)	145 (5.71)	75 (2.95)	M4	6 (13.2)
MR-J2-200A	FR-BAL-3.7K	220 (8.66)	95 (3.74)	200 (7.87)	200 (7.87)	70 (2.76)	M5	8.5 (18.7)
MR-J2-350A	FR-BAL-7.5K	220 (8.66)	125 (4.92)	205 (8.07)	200 (7.87)	100 (3.94)	M5	14.5 (32.0)

### 6-2-4 Relays

The following relays should be used with the interfaces:

Interface	Selection Example
Relay used especially for switching on-off analog input command and digital input command (interface DI-1) signals	To prevent defective contacts, use a relay for small signal (twin contacts). (Ex.) OMRON: type G2A, MY
Relay used for digital output signals (interface DO-1)	Small relay with 12VDC or 24VDC of 40mA or less (Ex.) OMRON: type MY

## 6. OPTIONS AND AUXILIARY EQUIPMENT

### 6-2-5 Surge absorbers

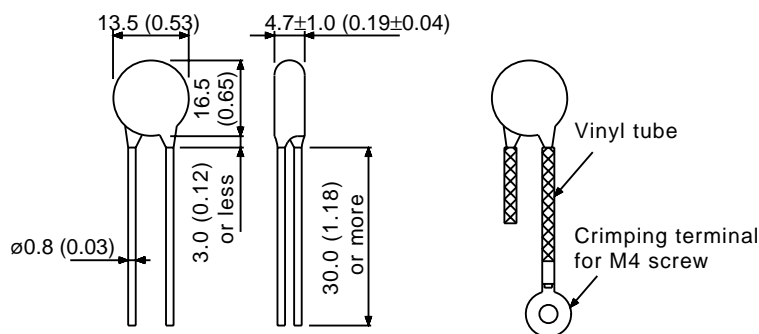
A surge absorber is required for the electromagnetic brake. Use the following surge absorber or equivalent.

Insulate the wiring as shown in the diagram.

Maximum Rating					Maximum Limit Voltage		Static Capacity (Reference value)	Varistor Voltage Rating (Range) $V_{1mA}$
Permissible circuit voltage		Surge immunity	Energy immunity	Rated power				
AC[V <sub>ma</sub> ]	DC[V]	[A]	[J]	[W]	[A]	[V]	[pF]	[V]
140	180	(Note) 500/time	5	0.4	25	360	300	220 (198 to 242)

Note: 1 time = 8 x 20 $\mu$ s

(Example) ERZV10D221 (Matsushita Electric)  
 TNR-12G221K (Marcon Electronics)  
 Outline drawing [mm] ( [in] ) (ERZ-C10DK221)



# 6. OPTIONS AND AUXILIARY EQUIPMENT

## 6-2-6 Noise reduction techniques

Noises are classified into external noises which enter the servo amplifier to cause it to malfunction and those radiated by the servo amplifier to cause peripheral devices to malfunction. Since the servo amplifier is an electronic device which handles small signals, the following general noise reduction techniques are required.

Also, the servo amplifier can be a source of noise as its outputs are chopped by high carrier frequencies. If peripheral devices malfunction due to noises produced by the servo amplifier, noise suppression measures must be taken. The measures will vary slightly with the routes of noise transmission.

### 1) General reduction techniques

- Avoid laying power lines (input and output cables) and signal cables side by side or do not bundle them together. Separate power lines from signal cables.
- Use shielded, twisted pair cables for connection with the encoder and for control signal transmission, and connect the shield to the SD terminal.
- Ground the servo amplifier, servo motor, etc. together at one point (refer to Section 3-4).

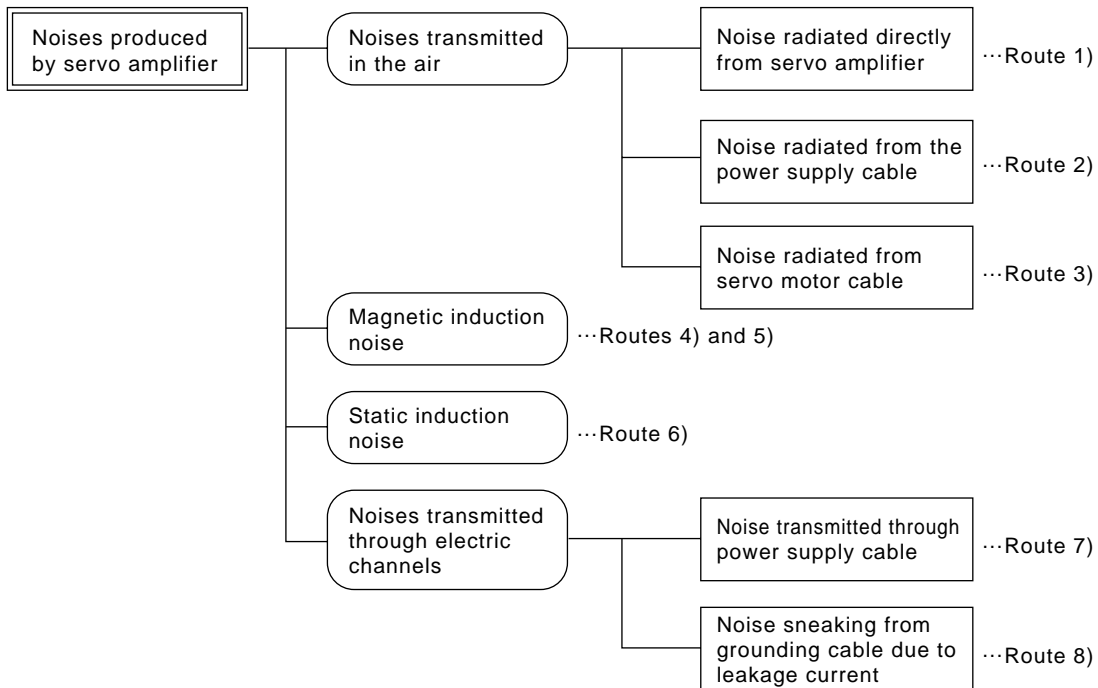
### 2) Reduction techniques for external noises that cause the servo amplifier to malfunction

If there are noise sources (such as a magnetic contactor, an electromagnetic brake, and many relays which make a large amount of noise) near the servo amplifier and the servo amplifier may malfunction, the following countermeasures are required.

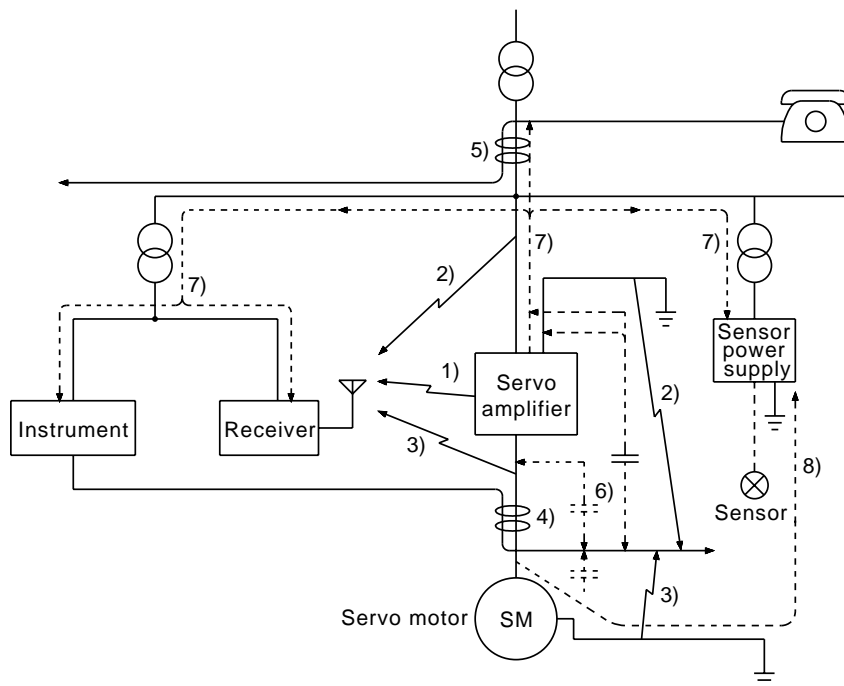
- Provide surge absorbers on the noise sources to suppress noises.
- Attach data line filters to the signal cables.
- Ground the shields of the encoder connecting cable and the control signal cables with cable clamp fittings.

### 3) Techniques for noises radiated by the servo amplifier that cause peripheral devices to malfunction

Noises produced by the servo amplifier are classified into those radiated from the cables connected to the servo amplifier and its main circuits (input and output circuits), those induced electromagnetically or statically by the signal cables of the peripheral devices located near the main circuit cables, and those transmitted through the power supply cables.



## 6. OPTIONS AND AUXILIARY EQUIPMENT



Noise Transmission Route	Suppression Techniques
1) 2) 3)	<p>When measuring instruments, receivers, sensors, etc. which handle weak signals and may malfunction due to noise and/or their signal cables are contained in a control box together with the servo amplifier or run near the servo amplifier, such devices may malfunction due to noises transmitted through the air. The following techniques are required.</p> <p>(1) Provide maximum clearance between easily affected devices and the servo amplifier.            (2) Provide maximum clearance between easily affected signal cables and the I/O cables of the servo amplifier.            (3) Avoid laying the power lines (I/O cables of the servo amplifier) and signal cables side by side or bundling them together.            (4) Insert a line noise filter to the I/O cables or a radio noise filter on the input line.            (5) Use shielded wires for signal and power cables or put cables in separate metal conduits.</p>
4) 5) 6)	<p>When the power lines and the signal cables are laid side by side or bundled together, magnetic induction noise and static induction noise will be transmitted through the signal cables and malfunction may occur. The following techniques are required.</p> <p>(1) Provide maximum clearance between easily affected devices and the servo amplifier.            (2) Provide maximum clearance between easily affected signal cables and the I/O cables of the servo amplifier.            (3) Avoid laying the power lines (I/O cables of the servo amplifier) and signal cables side by side or bundling them together.            (4) Use shielded wires for signal and power cables or put the cables in separate metal conduits.</p>
7)	<p>When the power supply of peripheral devices is connected to the power supply of the servo amplifier system, noises produced by the servo amplifier may be transmitted back through the power supply cable and the devices may malfunction. The following techniques are required.</p> <p>(1) Insert the radio noise filter (FR-BIF) on the power cables (Input line) of the servo amplifier.            (2) Insert the line noise filter (FR-BSF01) on the power cables of the servo amplifier.</p>
8)	<p>When the cables of peripheral devices are connected to the servo amplifier to make a closed loop circuit, leakage current may flow to malfunction the peripheral devices. If so, malfunction may be prevented by disconnecting the grounding cable of the peripheral device.</p>

## 6. OPTIONS AND AUXILIARY EQUIPMENT

### (1) Data line filter

Noise can be prevented by installing a data line filter onto the encoder cable, etc.

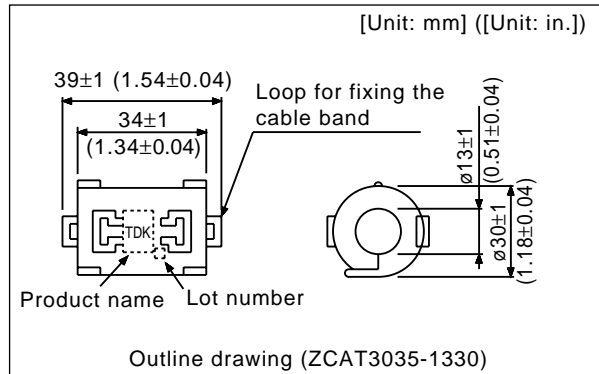
Example: Data line filter: ZCAT3035-1330 [TDK]

ESD-SR-25 [Tokin]

Impedance specifications (ZCAT3035-1330)

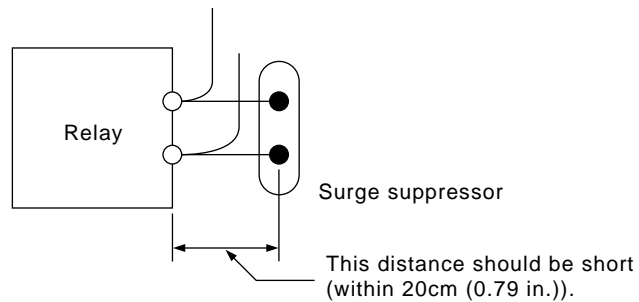
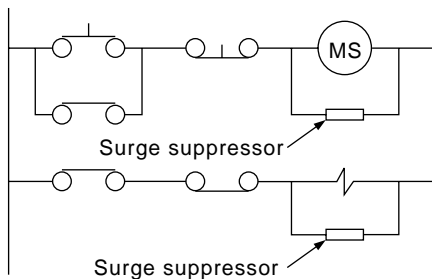
Impedance[Ω]	
10 to 100MHZ	100 to 500MHZ
80	150

The above impedances are reference values and not guaranteed values.



### (2) Surge suppressor

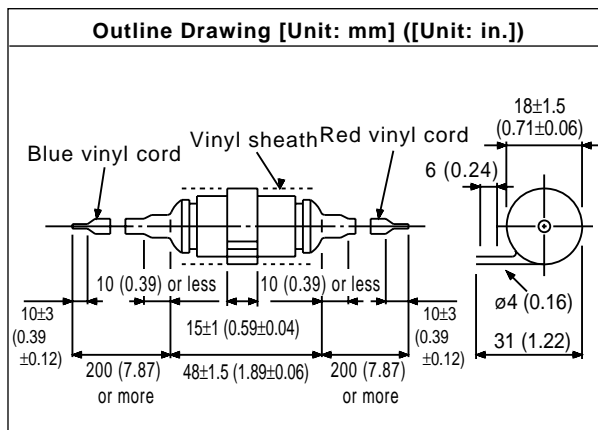
The recommended surge suppressor for installation to an AC relay, AC valve, AC electromagnetic brake or the like near the servo amplifier is shown below. Use this product or equivalent.



(Ex.) 972A-2003 504 11

(Matsuo Electric Co., Ltd. - 200VAC rating)

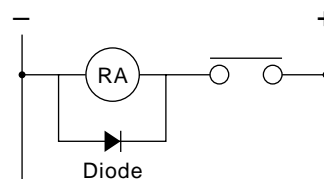
Rated Voltage AC[V]	C [μF]	R [Ω]	Test Voltage AC[V]
200	0.5	50 (1W)	Across T-C 1000(1 to 5s)



Note that a diode should be installed to a DC relay, DC valve or the like.

Maximum voltage: Not less than 4 times the drive voltage of the relay or the like

Maximum current: Not less than twice the drive current of the relay or the like



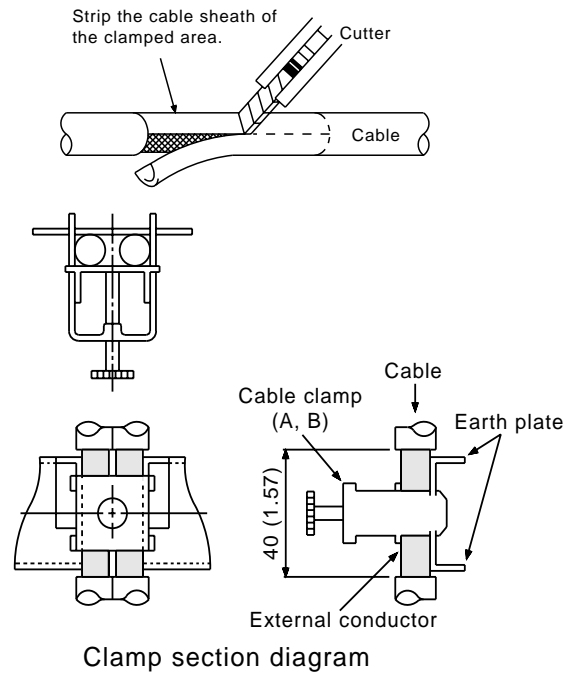
## 6. OPTIONS AND AUXILIARY EQUIPMENT

### (3) Cable clamp fitting (AERSBAN-□SET)

Generally, the earth of the shielded cable may only be connected to the connector's SD terminal. However, the effect can be increased by directly connecting the cable to an earth plate as shown below.

Install the earth plate near the servo amplifier for the encoder cable. Peel part of the cable sheath to expose the external conductor, and press that part against the earth plate with the cable clamp.

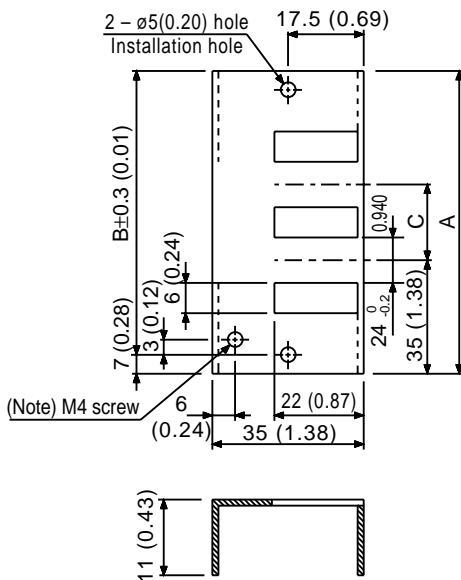
If the cable is thin, clamp several cables in a bunch. The clamp comes as a set with the earth plate.



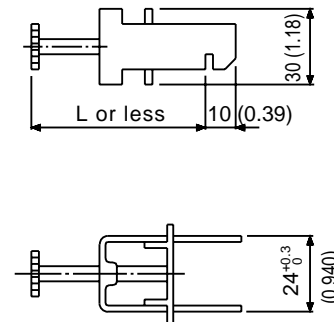
[Unit: mm]  
([Unit: in.])

#### • Outline drawing

Earth plate



Clamp section diagram



Note: Screw hole for grounding. Connect it to the earth plate of the control box.

Type	A	B	C	Accessory Fittings
AERSBAN – DSET	100 (3.94)	86 (3.39)	30 (1.18)	clamp A: 2pcs.
AERSBAN – ESET	70 (2.76)	56 (2.20)		clamp B: 1pc.

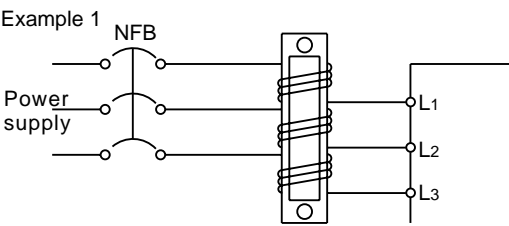
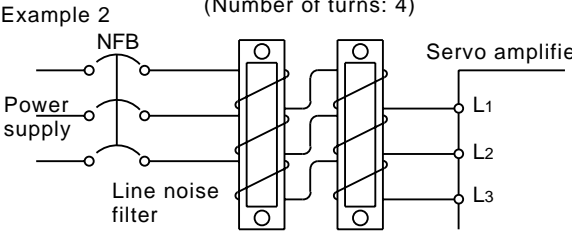
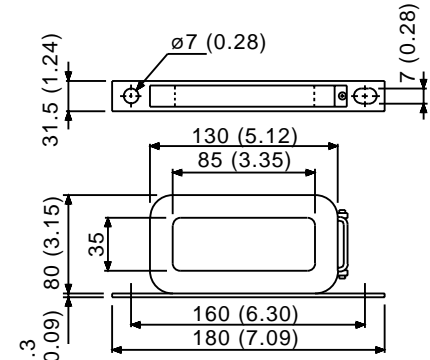
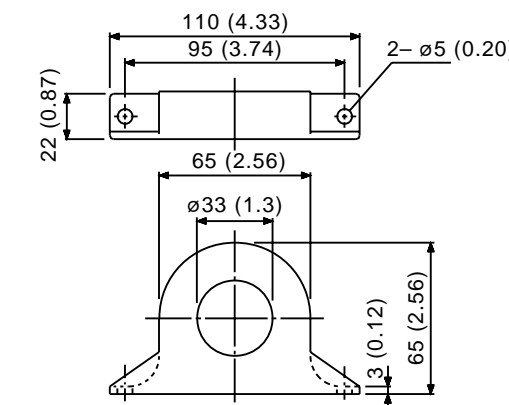
Clamp Fitting	L
A	70 (2.76)
B	45 (1.77)



## 6. OPTIONS AND AUXILIARY EQUIPMENT

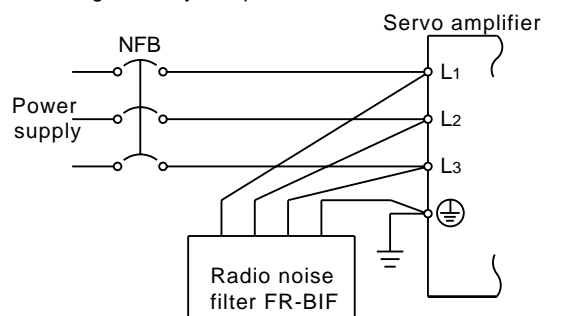
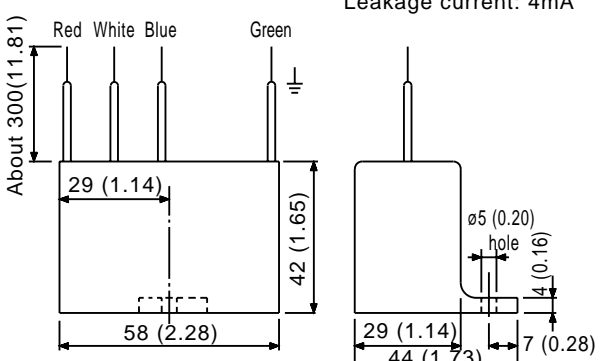
### (4) Line noise filter (FR-BLF, FR-BSF01)

This filter is effective in suppressing noises radiated from the power supply side and output side of the servo amplifier and also in suppressing high-frequency leakage current (zero-phase current) especially within 0.5MHz to 5MHz band.

Connection Diagram	Outline Drawing [Unit: mm] ([Unit: in.])
<p>Wind the three-phase wires by the equal number of times in the same direction, and connect the filter to the power supply side and output side of the servo amplifier.</p> <p>The effect of the filter on the power supply side is higher as the number of winds is larger. The number of turns is generally four. If the wires are too thick to be wound, use two or more filters and make the total number of turns as mentioned above.</p> <p>On the output side, the number of turns must be four or less.</p> <p>Do not wind the grounding wire together with the three-phase wires. The filter effect will decrease. Use a separate wire for grounding.</p> <p>Example 1</p>  <p>Example 2 (Number of turns: 4)</p>  <p>Two filters are used (Total number of turns: 4)</p>	<p>FR - BLF(MR - J2 - 350A)</p>  <p>(for MR-J2-200A or less)</p> 

### (5) Radio noise filter (FR-BIF)...for the input side only

This filter is effective in suppressing noises radiated from the power supply side of the servo amplifier especially in 10MHz and lower radio frequency bands. The FR-BIF is designed for the input only.

Connection Diagram	Outline Drawing (Unit: mm) ([Unit: in.])
<p>Make the connection cables as short as possible. Grounding is always required.</p> 	<p>Leakage current: 4mA</p> 

## 6. OPTIONS AND AUXILIARY EQUIPMENT

### 6-2-7 Leakage current breaker

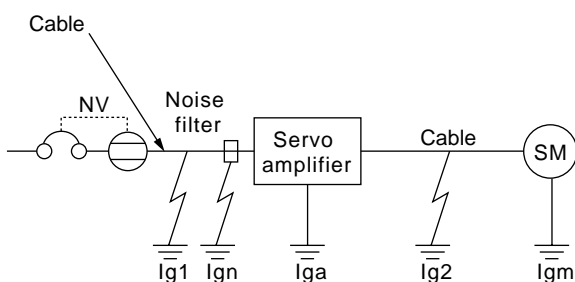
#### (1) Selection method

High-frequency chopper currents controlled by pulse width modulation flow in the AC servo circuits. Leakage currents containing harmonic contents are larger than those of the motor which is run with a commercial power supply.

Select a leakage current breaker according to the following formula, and ground the servo amplifier, servo motor, etc. securely.

Make the input and output cables as short as possible, and also make the grounding cable as long as possible (about 30cm (11.8 in)) to minimize leakage currents.

$$\text{Rated sensitivity current} \geq 10 \cdot \{I_{g1} + I_{gn} + I_{ga} + K \cdot (I_{g2} + I_{gm})\} \text{ [mA]} \dots (6-2)$$



K: Constant considering the harmonic contents

Leakage current breaker		
Type	Mitsubishi products	K
Models provided with harmonic and surge reduction techniques	NV - SF NV - CF	1
General models	NV - CA NV - CS NV - SS	3

I<sub>g1</sub>: Leakage current on the electric channel from the leakage current breaker to the input terminals of the servo amplifier (Found from Fig. 6-1.)

I<sub>g2</sub>: Leakage current on the electric channel from the output terminals of the servo amplifier to the servo motor (Found from Fig. 6-1.)

I<sub>gn</sub>: Leakage current when a filter is connected to the input side (4.4mA per one FR-BIF)

I<sub>ga</sub>: Leakage current of the servo amplifier (Found from Table 6-2.)

I<sub>gm</sub>: Leakage current of the servo motor (Found from Table 6-1.)

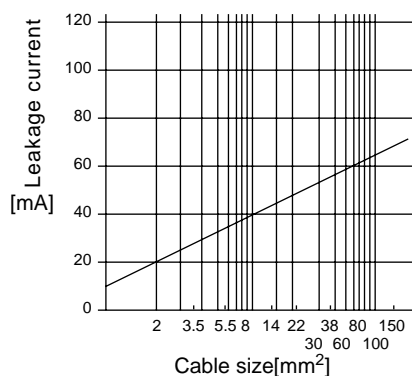


Fig. 6-1 Leakage Current Example (I<sub>g1</sub>, I<sub>g2</sub>) for CV Cable Run in Metal Conduit

Table 6-1 Servo Motor's Leakage Current Example (I<sub>gm</sub>)

Servo Motor Output [kW]	Leakage Current [mA]
0.05 to 0.5	0.1
0.6 to 1.0	0.1
1.2 to 2.2	0.2
3 • 3.5	0.3

Table 6-2 Servo Amplifier's Leakage Current Example (I<sub>ga</sub>)

Servo Amplifier Capacity [kW]	Leakage Current [mA]
0.1 to 0.6	0.1
0.7 to 3.5	0.15

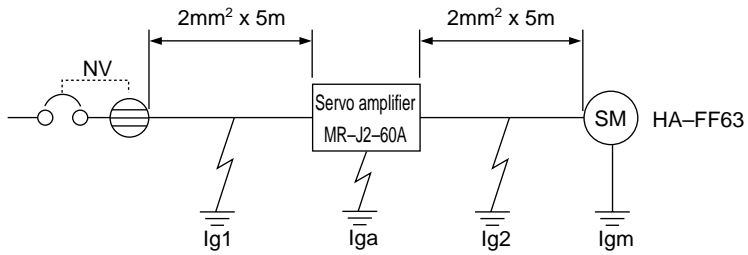
Table 6-3 Leakage Circuit Breaker Selection Example

Servo Amplifier	Rated Sensitivity Current of Leakage Circuit Breaker
MR - J2 - 10A to MR - J2 - 350A MR - J2 - 10A1 to MR - J2 - 40A1	15 [mA]

## 6. OPTIONS AND AUXILIARY EQUIPMENT

### (2) Selection example

Indicated below is an example of selecting a leakage current breaker under the following conditions:



Use a leakage current breaker generally available.  
Find the terms of Equation (6-2) from the diagram:

$$I_{g1} = 20 \cdot \frac{5}{1000} = 0.1[\text{mA}]$$

$$I_{g2} = 20 \cdot \frac{5}{1000} = 0.1[\text{mA}]$$

$$I_{gn} = 0 \text{ (not used)}$$

$$I_{ga} = 0.1[\text{mA}]$$

$$I_{gm} = 0.1[\text{mA}]$$

Insert these values in Equation (6-2):

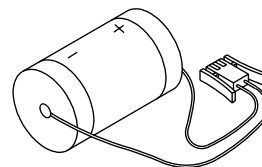
$$I_g \geq 10 \cdot \{0.1 + 0 + 0.1 + 3 \cdot (0.1 + 0.1)\}$$

$$\geq 8.0[\text{mA}]$$

According to the result of calculation, use a leakage current breaker having the rated sensitivity current ( $I_g$ ) of 8.0[mA] or more. A leakage current breaker having  $I_g$  of 15[mA] is used with the NV-CA/CS/SS series.

### 6-2-8 Battery (MR-BAT, A6BAT)

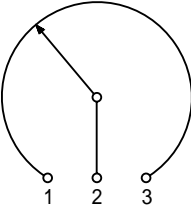
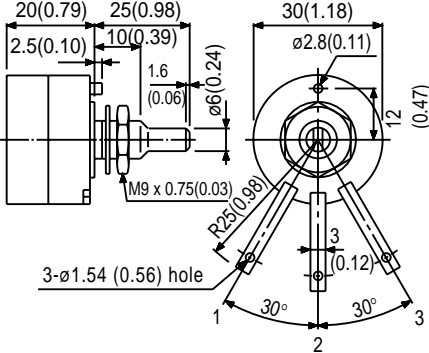
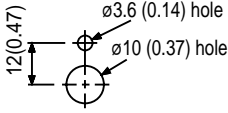
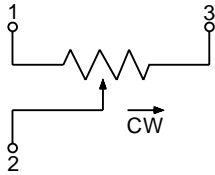
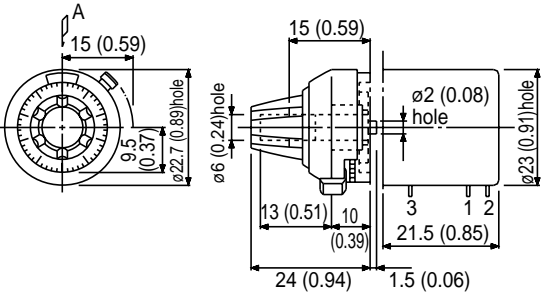
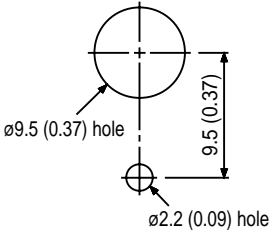
Use the battery to build an absolute position detection system.



## 6. OPTIONS AND AUXILIARY EQUIPMENT

### 6-2-9 Setting potentiometers for analog inputs

The following variable resistors are available for use with analog inputs such as analog speed and torque commands:

Single-revolution type	<p>Model: WA2WYA2SEBK2KΩ Wire-wound variable resistor 2W2KΩ B characteristic Shaft rotary angle Note: Manufacturer (Japan Resistor) standard WA2W usable Connection diagram</p>															
	<p>Outline dimension drawing [Unit: mm] ([Unit: in.])</p> 	<p>Panel hole machining diagram [Unit: mm] ([Unit: in.])</p> 														
	<table border="1"> <thead> <tr> <th>Rated Power</th> <th>Resistance</th> <th>Resistance Tolerance</th> <th>Dielectric Strength (for 1 minute)</th> <th>Insulation Resistance</th> <th>Mechanical Rotary Angle</th> <th>Rotary Torque</th> </tr> </thead> <tbody> <tr> <td>2W</td> <td>2kΩ</td> <td>±10%</td> <td>700V A.C</td> <td>100MΩ or more</td> <td>300°±5°</td> <td>10 to 100g-cm or less</td> </tr> </tbody> </table>	Rated Power	Resistance	Resistance Tolerance	Dielectric Strength (for 1 minute)	Insulation Resistance	Mechanical Rotary Angle	Rotary Torque	2W	2kΩ	±10%	700V A.C	100MΩ or more	300°±5°	10 to 100g-cm or less	
Rated Power	Resistance	Resistance Tolerance	Dielectric Strength (for 1 minute)	Insulation Resistance	Mechanical Rotary Angle	Rotary Torque										
2W	2kΩ	±10%	700V A.C	100MΩ or more	300°±5°	10 to 100g-cm or less										
Multi-revolution type	<p>Model: Helical pot RRS10(M) 2KΩ Japan Resistor make</p>															
	<p>Outline dimension drawing [Unit: mm] ([Unit: in.])</p> 	<p>Panel hole machining diagram [Unit: mm] ([Unit: in.]) Panel thickness: 2 to 6 (0.08 to 0.24)</p> 														
	<table border="1"> <thead> <tr> <th>Rated Power</th> <th>Resistance</th> <th>Resistance Tolerance</th> <th>Dielectric Strength (for 1 minute)</th> <th>Insulation Resistance</th> <th>Mechanical Rotary Angle</th> <th>Rotary Torque</th> </tr> </thead> <tbody> <tr> <td>1W</td> <td>2kΩ</td> <td>±10%</td> <td>700V A.C</td> <td>1000MΩ or more</td> <td>3600° + 10° - 0°</td> <td>100g-cm or less</td> </tr> </tbody> </table>	Rated Power	Resistance	Resistance Tolerance	Dielectric Strength (for 1 minute)	Insulation Resistance	Mechanical Rotary Angle	Rotary Torque	1W	2kΩ	±10%	700V A.C	1000MΩ or more	3600° + 10° - 0°	100g-cm or less	
Rated Power	Resistance	Resistance Tolerance	Dielectric Strength (for 1 minute)	Insulation Resistance	Mechanical Rotary Angle	Rotary Torque										
1W	2kΩ	±10%	700V A.C	1000MΩ or more	3600° + 10° - 0°	100g-cm or less										

# CHAPTER 7

## INSPECTION

---

This chapter describes inspection items.

<b>INTRODUCTION</b>	<b>CHAPTER 1</b>
<b>OPERATION</b>	<b>CHAPTER 2</b>
<b>WIRING</b>	<b>CHAPTER 3</b>
<b>INSTALLATION</b>	<b>CHAPTER 4</b>
<b>ABSOLUTE POSITION DETECTION SYSTEM</b>	<b>CHAPTER 5</b>
<b>OPTIONS AND AUXILIARY EQUIPMENT</b>	<b>CHAPTER 6</b>
<b>INSPECTION</b>	<b>CHAPTER 7</b>
<b>TROUBLESHOOTING</b>	<b>CHAPTER 8</b>
<b>CHARACTERISTICS</b>	<b>CHAPTER 9</b>
<b>SPECIFICATIONS</b>	<b>CHAPTER 10</b>
<b>SELECTION</b>	<b>CHAPTER 11</b>

## 7.INSPECTION

 **WARNING**

1. Before starting maintenance and/or inspection, make sure that the charge lamp is off more than 10 minutes after power-off. Then, confirm that the voltage is safe in the tester or the like. Otherwise, you may get an electric shock.
2. Any person who is involved in inspection should be fully competent to do the work. Otherwise, you may get an electric shock. For repair and parts replacement, contact your safes representative.

**NOTICE**

1. Do not test the servo amplifier with a megger (measure insulation resistance), or it may become faulty.
2. Do not disassemble and/or repair the equipment on customer side.

(1) Inspection

It is recommended to make the following checks periodically:

- 1) Check for loose terminal block screws. Retighten any loose screws.
- 2) Check the servo motor bearings, brake section, etc. for unusual noise.
- 3) Check the cables and the like for scratches and cracks. Perform periodic inspection according to operating conditions.
- 4) Check the servo motor shaft and coupling for misalignment.

(2) Life

The following parts must be changed periodically as listed below. If any part is found faulty, it must be changed immediately even when it has not yet reached the end of its life, which depends on the operating method and environmental conditions.

When using the servo motor in an atmosphere where there is much oil mist or dust, clean and inspect the motor every three months.

For parts replacement, please contact your sales representative.

Part Name		Standard Life
Servo amplifier	Smoothing capacitor	10 years
	Relay	The number of power inputs reaches 100,000 times.
	Cooling fan	10,000 to 30,000 hours (2 to 3 years)
	Absolute position battery	Refer to Chapter 5 (2).
Servo motor	Bearings	20,000 to 30,000 hours
	Encoder	20,000 to 30,000 hours
	Oil seal, V ring	5,000 hours

## 7.INSPECTION

---

- 1) Smoothing capacitor: Affected by ripple currents, etc. and deteriorates in characteristic. The life of the capacitor greatly depends on ambient temperature and operating conditions. The capacitor will reach the end of its life in 10 years of continuous operation in normal air-conditioned environment.
- 2) Relays : Their contacts will wear due to switching currents and contact faults occur. Depending on the capacity of the power supply, the service life terminates when the number of power inputs reaches 100,000 times.
- 3) Servo amplifier cooling fan : The cooling fan bearings reach the end of their life in 10,000 to 30,000 hours. Normally, therefore, the fan must be changed in a few years of continuous operation as a guideline.  
It must also be changed if unusual noise or vibration is found during inspection.
- 4) Servo motor bearings: When the servo motor is run at rated speed under rated load, change the bearings in 20,000 to 30,000 hours as a guideline. This differs on the operating conditions. The bearings must also be changed if unusual noise or vibration is found during inspection.
- 5) Servo motor oil seal, V ring: Must be changed in 5,000 hours of operation at rated speed as a guideline. This differs on the operating conditions. These parts must also be changed if oil leakage, etc. is found during inspection.

# CHAPTER 8

## TROUBLESHOOTING

---

This chapter gives troubleshooting at start-up and corrective actions for alarms and warnings. When any fault has occurred, refer to this chapter and take the corresponding action.

- 8-1 Troubleshooting at start-up
  - 8-1-1 Position control mode
  - 8-1-2 Speed control mode
  - 8-1-3 Torque control mode
- 8-2 Alarms and warnings
  - 8-2-1 Alarm and warning list
  - 8-2-2 Alarms
  - 8-2-3 Warnings

<b>INTRODUCTION</b>	<b>CHAPTER 1</b>
<b>OPERATION</b>	<b>CHAPTER 2</b>
<b>WIRING</b>	<b>CHAPTER 3</b>
<b>INSTALLATION</b>	<b>CHAPTER 4</b>
<b>ABSOLUTE POSITION DETECTION SYSTEM</b>	<b>CHAPTER 5</b>
<b>OPTIONS AND AUXILIARY EQUIPMENT</b>	<b>CHAPTER 6</b>
<b>INSPECTION</b>	<b>CHAPTER 7</b>
<b>TROUBLESHOOTING</b>	<b>CHAPTER 8</b>
<b>CHARACTERISTICS</b>	<b>CHAPTER 9</b>
<b>SPECIFICATIONS</b>	<b>CHAPTER 10</b>
<b>SELECTION</b>	<b>CHAPTER 11</b>



## 8. TROUBLESHOOTING

### 8-1 Troubleshooting at start-up

**⚠ CAUTION** Excessive adjustment or change of parameter setting must not be made as it will make operation instable.

The following faults may occur at start-up. If any of such faults occurs, take the corresponding action.

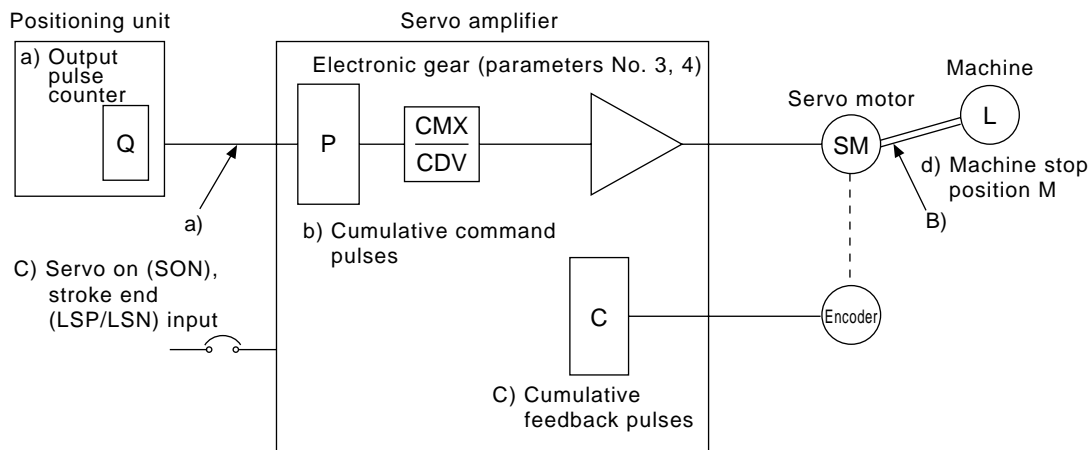
#### 8-1-1 Position control mode

##### (1) Troubleshooting

No.	Start-Up Sequence	Fault	Investigation	Possible Cause	Refer To
1	Power on	<ul style="list-style-type: none"> <li>• LED is not lit.</li> <li>• LED flickers.</li> </ul>	Not improved if connectors CN1A, CN1B and CN2 are disconnected.	1) Power supply voltage fault 2) Servo amplifier is faulty.	/
			Improved when connectors CN1A and CN1B are disconnected.	Power supply of CN1 cabling is shorted.	
			Improved when connector CN2 is disconnected.	1) Power supply of encoder cabling is shorted. 2) Encoder is faulty.	
			Improved when connector CN3 is disconnected.	Power supply is shorted.	
		Alarm occurs.	Refer to Section 8-2 and remove cause.		Section 8-2
2	Switch on servo-on signal.	Alarm occurs.	Refer to Section 8-2 and remove cause.		Section 8-2
		Servo motor shaft is not servo-locked (is free).	1. Check the display to see if the servo amplifier is ready to operate. 2. Check the external I/O signal indication to see if the servo-on (SON) signal is ON.	1) Servo on signal is not input. (Wiring mistake) 2) 24VDC power is not supplied to COM.	(1), Section 2-3-3
3	Enter input command. (Test operation)	Servo motor does not rotate.	Check cumulative command pulses.	1) Wiring mistake (a) For open collector pulse train input, 24VDC power is not supplied to OPC. (b) LSP/LSN-SG are not connected. 2) No pulse is input.	Section 2-3-2
4	Gain adjustment	Rotational ripples (speed fluctuations) are large at low speed.	Make gain adjustment in the following procedure: 1) Increase the auto tuning response level. 2) Repeat acceleration and deceleration several times to complete auto tuning.	Gain adjustment fault	Section 2-4
		Large load inertia moment causes the servo motor to oscillate side to side.	Make gain adjustment in the following procedure: If the servo motor may be run with safety, repeat acceleration and deceleration several times to complete auto tuning.	Gain adjustment fault	Section 2-4
5	Cyclic operation	Position shift occurs.	Confirm the cumulative command pulses, cumulative feedback pulses and actual servo motor position.	Pulse counting error, etc. due to noise.	(2) in this section

## 8. TROUBLESHOOTING

### (2) How to find the cause of position shift



When a position shift occurs, check a) output pulse counter, b) cumulative command pulse display, c) cumulative feedback pulse display, and d) machine stop position in the above diagram. A), B) and C) indicate position shift causes. For example, A) indicates that noise entered the wiring between positioning unit and servo amplifier, causing pulses to be mis-counted.

In a normal status without position shift, there are the following relationships:

- 1)  $Q = P$  (positioning unit's output counter = servo amplifier's cumulative command pulses)
- 2)  $P \cdot \frac{CMX}{CDV}$  (parameter No. 3)  
(parameter No. 4)  
= C (cumulative command pulses x electronic gear = cumulative feedback pulses)
- 3)  $C \cdot \Delta l = M$  (cumulative feedback pulses x travel per pulse = machine position)

Check for a position shift in the following sequence:

- 1) When  $Q \neq P$   
Noise entered the pulse train signal wiring between positioning unit and servo amplifier, causing pulses to be mis-counted. (Cause A)  
Make the following check or take the following measures:
  - Check how the shielding is done.
  - Change the open collector system to the differential line driver system.
  - Run wiring away from the power circuit.
  - Install a data line filter. (Refer to Section 6.2.6 (1).)
- 2) When  $P \cdot \frac{CMX}{CDV} \neq C$   
During operation, the servo on signal (SON) or forward/reverse rotation stroke end signal was switched off or the clear signal (CR) and the reset signal (RES) switched on. (Cause C)  
If a malfunction may occur due to much noise, increase the input filter setting (parameter No. 1).
- 3) When  $C \cdot \Delta l \neq M$   
Mechanical slip occurred between the servo motor and machine. (Cause B)

## 8. TROUBLESHOOTING

### 8-1-2 Speed control mode

No.	Start-Up Sequence	Fault	Investigation	Possible Cause	Refer To
1	Power on	<ul style="list-style-type: none"> <li>• LED is not lit.</li> <li>• LED flickers.</li> </ul>	Not improved if connectors CN1A, CN1B and CN2 are disconnected.	1) Power supply voltage fault 2) Servo amplifier faulty.	/
			Improved when connectors CN1A and CN1B are disconnected.	Power supply of CN1 cabling is shorted.	
			Improved when connector CN2 is disconnected.	1) Power supply of encoder cabling is shorted. 2) Encoder is faulty.	
		Alarm occurs.	Refer to Section 8-2 and remove cause.	Section 8-2	
2	Switch on servo-on signal.	Alarm occurs.	Refer to Section 8-2 and remove cause.	Section 8-2	
		Servo motor shaft is free.	1. Check the display to see if the servo amplifier is ready to operate. 2. Check the external I/O signal indication to see if the servo-on (SON) signal is ON.	(Wiring mistake) 2) 24VDC power is not supplied to COM. (1), Section 2-3-3	
3	Switch on forward rotation start (ST1) or reverse rotation start (ST2).	Servo motor does not rotate.	Call the status display and check the input voltage of the analog speed command.	Analog speed command is 0V.	Section 2-3-2
			Call the external I/O signal display and check the ON/OFF status of the input signal.	LSP, LSN, ST1 or ST2 is off.	(1), Section 2-3-3
			Check the internal speed commands 1 to 3 (parameters No. 8 to 10).	Set value is 0.	(3), Section 2-3-5
			Check the internal torque limit 1 (parameter No. 28).	Set value is 0.	
4	Gain adjustment	Rotational ripples (speed fluctuations) are large at low speed.	Make gain adjustment in the following procedure: 1) Increase the auto tuning response level. 2) Repeat acceleration and deceleration several times to complete auto tuning.	Gain adjustment fault	Section 2-4
		Large load inertia moment causes the servo motor to oscillate side to side.	Make gain adjustment in the following procedure: If the servo motor may be run with safety, repeat acceleration and deceleration several times to complete auto tuning.	Gain adjustment fault	Section 2-4

## 8. TROUBLESHOOTING

### 8-1-3 Torque control mode

No.	Start-Up Sequence	Fault	Investigation	Possible Cause	Refer To
1	Power on	<ul style="list-style-type: none"> <li>• LED is not lit.</li> <li>• LED flickers.</li> </ul>	Not improved if connectors CN1A, CN1B and CN2 are disconnected.	1) Power supply voltage fault 2) Servo amplifier faulty.	/
			Improved when connectors CN1A and CN1B are disconnected.	Power supply of CN1 cabling is shorted.	
			Improved when connector CN2 is disconnected.	1) Power supply of encoder cabling is shorted. 2) Encoder is faulty.	
		Alarm occurs.	Refer to Section 8-2 and remove cause.	Section 8-2	
2	Switch on servo-on signal.	Alarm occurs.	Refer to Section 8-2 and remove cause.		Section 8-2
3	Switch on forward rotation start (RS1) or reverse rotation start (RS2).	Servo motor does not rotate.	Call the status display and check the analog torque command.	Analog torque command is 0V.	Section 2-3-2
			Call the external I/O signal display and check the ON/OFF status of the input signal.	RS1 or RS2 is off.	(1), Section 2-3-3
			Check the internal speed limits 1 to 3 (parameters No. 8 to 10).	Set value is 0.	(3), Section 2-3-5
			Check the internal torque limit 1 (parameter No. 28).	Set value is 0.	

## 8. TROUBLESHOOTING

### 8-2 Alarms and warnings

#### 8-2-1 Alarm and warning list

When a fault occurs during operation, the corresponding alarm or warning is displayed. If any alarm or warning has occurred, refer to Section 8-2-2 or 8-2-3 and take the appropriate action. Set □□□1 in parameter No. 49 to output the alarm code in ON/OFF status across the corresponding pin and SG. Warnings (A. 92 to A. EA) have no codes. Any alarm code is output at occurrence of the corresponding alarm. In the normal status, the signals available before alarm code setting (CN1B-19: ZSP, CN1A-18: INP or SA, CN1A-19: RD) are output.

	Display	(Note) Alarm Code			Name
		CN1B-19 pin	CN1A-18 pin	CN1A-19 pin	
Alarms	A. 10	0	1	0	Undervoltage
	A. 11	0	0	0	Board error1
	A. 12	0	0	0	Memory error1
	A. 13	0	0	0	Clock error
	A. 15	0	0	0	Memory error2
	A. 16	1	1	0	Encoder error1
	A. 17	0	0	0	Board error2
	A. 18	0	0	0	Board error3
	A. 20	1	1	0	Encoder error2
	A. 24	1	0	0	Ground fault
	A. 25	1	1	0	Absolute position erase
	A. 30	0	0	1	Regenerative error
	A. 31	1	0	1	Overspeed
	A. 32	1	0	0	Overcurrent
	A. 33	0	0	1	Overvoltage
	A. 35	1	0	1	Command pulse frequency alarm
	A. 37	0	0	0	Parameter error
	A. 46	0	1	1	Servo motor overheat
	A. 50	0	1	1	Overload1
	A. 51	0	1	1	Overload2
A. 52	1	0	1	Error excessive	
A. 8E	0	0	0	RS-232C error	
8888	0	0	0	Watchdog	
Warnings	A. 92				Open battery cable warning
	A. 96				Zero setting error
	A. 9F				Battery warning
	A. E0				Excessive regenerative load warning
	A. E1				Overload warning
	A. E3				Absolute position counter warning
	A. E5				ABS time-out warning
	A. E6				Servo emergency stop
	A. E9				Main circuit off warning
	A. EA				ABS servo on warning

NOTE, 0:OFF 1:ON

## 8. TROUBLESHOOTING

### 8-2-2 Alarms

#### WARNING

1. When any alarm has occurred, eliminate its cause, ensure safety, then reset the alarm, and restart operation. Otherwise, injury may occur.
2. If an absolute position erase alarm (A. 25) occurred, always make home position setting again. Otherwise, misoperation may occur.

#### NOTICE

When any of the following alarms has occurred, always remove its cause and allow about 30 minutes for cooling before resuming operation. If operation is repeated by switching control circuit power off, then on to reset the alarm, the servo amplifier, servo motor and regenerative brake option may become faulty.

- Regenerative error (A. 30)
- Overload 1 (A. 50)
- Overload 2 (A. 51)

When an alarm occurs, the trouble signal (ALM) switches off and the dynamic brake is operated to stop the servomotor. At this time, the display indicates the alarm No.

Display	Alarm Code			Name	Definition	Cause	Action
	CN1B-19 pin	CN1A-18 pin	CN1A-19 pin				
A. 10	0	1	0	Undervoltage	Power supply voltage dropped. MR-J2-□A: 160V or less MR-J2-□A1: 83V or less	<ol style="list-style-type: none"> <li>1. Power supply voltage is low.</li> <li>2. Power failed instantaneously for 15ms or longer.</li> <li>3. Shortage of power supply capacity caused the power supply voltage to drop at start, etc.</li> <li>4. Power switched on within 5 seconds after it had switched off.</li> <li>5. Faulty parts in the servo amplifier</li> </ol>	<p>Review the power supply.</p> <p>Change the servo amplifier.</p>
						<p>— Checking method —</p> <p>Alarm (A. 10) occurs if power is switched on after CN1A, CN1B, and CN3 connectors are disconnected.</p>	
A. 11	0	0	0	Board error 1	Printed board faulty	Faulty parts in the servo amplifier	Change the servo amplifier.
A. 12	0	0	0	Memory error 1	RAM, ROM memory fault	<p>— Checking method —</p> <p>Alarm (any of A. 11 to 15) occurs if power is switched on after CN1A, CN1B, and CN3 connectors are disconnected.</p>	
A. 13	0	0	0	Clock error	Printed board fault		
A. 15	0	0	0	Memory error 2	EEPROM fault		
A. 16	1	1	0	Encoder error 1	Communication error occurred between encoder and servo amplifier.	<ol style="list-style-type: none"> <li>1. Encode connector disconnected.</li> <li>2. Encoder fault</li> <li>3. Encoder cable faulty (Wire breakage or short)</li> <li>4. Combination of servo amplifier and servo motor is not proper.</li> </ol>	<p>Connect correctly.</p> <p>Change the servo motor.</p> <p>Repair or change cable.</p> <p>Use correct combination</p>

## 8. TROUBLESHOOTING

Display	Alarm Code			Name	Definition	Cause	Action
	CN1B-19 pin	CN1A-18 pin	CN1A-19 pin				
A. 17	0	0	0	Board error 2	CPU/parts fault	Faulty parts in the servo amplifier ————— Checking method ————— Alarm (A. 17 or A. 18) occurs if power is switched on after CN1A, CN1B, and CN3 connectors have been disconnected.	Change the servo amplifier.
A. 18	0	0	0	Board error 3			
A. 20	1	1	0	Encoder error 2	Communication error occurred between encoder and servo amplifier.	1. Encoder connector disconnected. 2. Encoder cable faulty (wire breakage or short)	Connect correctly. Repair or change the cable.
A. 24	1	0	0	Motor output ground fault	Ground fault occurred at servo motor outputs (U, V, W phases) of servo amplifier.	1. Power input wires and servo motor output wires are in contact at main circuit terminal block (TE1).	Connect correctly.
						2. The servo motor power line cover is deteriorated, and causes earthing.	Replace the line.
						3. The main circuit of the servo amplifier is broken. ————— Investigating method ————— Disconnect the U, V, and W power lines from the servo amplifier, and turn on the servo motor. A. 24 still occurs.	Replace the servo amplifier.
A. 25	1	1	0	Absolute position erase	Absolute position data in error	1. Reduced voltage of super capacitor in encoder	After leaving the alarm occurring for a few minutes, switch power off, then on again. Ensure to make home position return again.
						2. Battery voltage low	
						3. Battery cable or battery is faulty.	After leaving the alarm occurring for a few minutes, switch power off, then on again. Home position setting must be made again.
						4. Super capacitor of the absolute position encoder is not charged	
A. 30	0	0	1	Regenerative error	The permissible regenerative power of the built-in regenerative brake resistor or regenerative brake option is exceeded.	1. Wrong setting of parameter No. 0	Set correctly.
						2. Built-in regenerative brake resistor or regenerative brake option is not connected.	Connect correctly.
						3. High-duty operation or continuous regenerative operation caused the permissible regenerative power of the regenerative brake option to be exceeded. ————— Checking method ————— Call the status display and check the regenerative load ratio.	1. Reduce the frequency of positioning. 2. Use the regenerative brake option of larger capacity. 3. Reduce the load.
				4. Power supply voltage increased to 260V or more.	Review power supply.		
				Regenerative transistor fault	Regenerative transistor fault	5. Regenerative transistor faulty. ————— Checking method ————— 1) The regenerative brake option has overheated abnormally. 2) The alarm occurs after removal of the built-in regenerative brake resistor or regenerative brake option.	Change the servo amplifier.
						6. Built-in regenerative brake resistor or regenerative brake option faulty.	Change servo amplifier or regenerative brake option.

## 8. TROUBLESHOOTING

Display	Alarm Code			Name	Definition	Cause	Action
	CN1B-19 pin	CN1A-18 pin	CN1A-19 pin				
A. 31	1	0	1	Overspeed	Speed has exceeded the instantaneous permissible speed.	1. Input command pulse frequency exceeded the permissible instantaneous speed frequency.	Set command pulses correctly.
						2. Small acceleration/deceleration time constant caused overshoot to be large.	Increase the acceleration/deceleration time constant.
						3. Servo system is instable to cause overshoot.	1. Re-set servo gain to proper value. 2. If servo gain cannot be set to proper value: 1) Reduce load inertia moment ratio; or 2) Reexamine acceleration/deceleration time constant.
						4. Electronic gear ratio is large (parameters No. 3, 4).	Set correctly.
						5. Encoder faulty.	Change the servo motor.
A. 32	1	0	0	Overcurrent	Current that flew is higher than the permissible current of the servo amplifier.	1. Short occurred in servo amplifier output phases U, V and W.	Correct the wiring.
						2. Transistor (IPM) of the servo amplifier faulty.	Change the servo amplifier.
						<div style="border: 1px solid black; padding: 5px; width: fit-content;">                     — Checking method —                      Alarm (A. 32) occurs if power is switched on after U, V and W connectors are disconnected.                 </div>	
						3. Ground fault occurred in servo amplifier output phases U, V and W.	Correct the wiring.
						4. External noise caused the overcurrent detection circuit to misoperate.	Take noise suppression measures.
A. 33	0	0	1	Overvoltage	Converter bus voltage exceeded 400V.	1. Lead of built-in regenerative brake resistor or regenerative brake option is open or disconnected.	1. Change lead. 2. Connect correctly.
						2. Regenerative transistor faulty.	Change servo amplifier.
						3. Wire breakage of built-in regenerative brake resistor or regenerative brake option	1. For wire breakage of built-in regenerative brake resistor, change servo amplifier. 2. For wire breakage of regenerative brake option, change regenerative brake option.
						4. Capacity of built-in regenerative brake resistor or regenerative brake option is insufficient.	Add regenerative brake option or increase capacity.



## 8. TROUBLESHOOTING

Display	Alarm Code			Name	Definition	Cause	Action
	CN1B-19 pin	CN1A-18 pin	CN1A-19 pin				
A. 35	1	0	1	Command pulse alarm	Input command pulses are too high.	1. Command pulse frequency is too high.	Reduce the command pulse frequency to proper value.
						2. Noise entered command pulses.	Take measures against noise.
						3. Command unit faulty.	Change the command unit.
A. 37	0	0	0	Parameter error	Parameter setting is wrong.	1. Servo amplifier fault caused the parameter setting to be rewritten.	Change the servo amplifier.
						2. Regenerative brake option not used with servo amplifier was selected in parameter No. 0.	Set parameter No. 0 correctly.
A. 46	0	1	1	Servo motor overheat	Servo motor temperature rise actuated the thermal protector.	1. Ambient temperature of servo motor is over 40°C.	Review environment so that ambient temperature is 0 to 40°C.
						2. Servo motor is overloaded.	1. Reduce load. 2. Review operation pattern. 3. Use servo motor that provides larger output.
						3. Thermal protector in encoder is faulty.	Change servo motor.
A. 50	0	1	1	Overload 1	Load exceeded overload protection characteristic of servo amplifier. Load ratio 300%: 2.5s or more Load ratio 200%: 100s or more	1. Servo amplifier is used in excess of its continuous output current.	1. Reduce load. 2. Review operation pattern. 3. Use servo motor that provides larger output.
						2. Servo system is instable and hunting.	1. Repeat acceleration/ deceleration to execute auto tuning. 2. Change auto tuning response level setting. 3. Set auto tuning to OFF and make gain adjustment manually.
						3. Machine struck something.	1. Review operation pattern. 2. Install limit switches.

## 8. TROUBLESHOOTING

Display	Alarm Code			Name	Definition	Cause	Action
	CN1B-19 pin	CN1A-18 pin	CN1A-19 pin				
A. 50	0	1	1	Overload 1		4. Wrong connection of servo motor. Servo amplifier's output terminals U, V, W do not match servo motor's input terminals U, V, W.	Connect correctly.
						5. Encoder faulty.  <div style="border: 1px solid black; padding: 5px;"> <p style="text-align: center;">————— Checking method —————</p> <p>When the servo motor shaft is rotated slowly with the servo off, the cumulative feedback pulses should vary in proportion to the rotary angle. If the indication skips or returns midway, the encoder is faulty.</p> </div>	Change the servo motor.
A. 51	0	1	1	Overload 2	Machine collision or the like caused max. output current to flow successively for several seconds. Servo motor locked: 1s or more	1. Machine struck something.	1. Review operation pattern. 2. Install limit switches.
						2. Wrong connection of servo motor. Servo amplifier's output terminals U, V, W do not match servo motor's input terminals U, V, W.	Connect correctly.
						3. Servo system is instable and hunting.	1. Repeat acceleration/ deceleration to execute auto tuning. 2. Change auto tuning response level setting. 3. Set auto tuning to OFF and make gain adjustment manually.
						4. Encoder faulty.  <div style="border: 1px solid black; padding: 5px;"> <p style="text-align: center;">————— Checking method —————</p> <p>When the servo motor shaft is rotated slowly with the servo off, the cumulative feedback pulses should vary in proportion to the rotary angle. If the indication skips or returns midway, the encoder is faulty.</p> </div>	Change the servo motor.

## 8. TROUBLESHOOTING

Display	Alarm Code			Name	Definition	Cause	Action
	CN1B-19 pin	CN1A-18 pin	CN1A-19 pin				
A. 52	1	0	1	Error excessive	Droop pulse value of the deviation counter exceeded 80k pulses.	1. Acceleration/deceleration time constant is too small.	Increase the acceleration/deceleration time constant.
						2. Torque limit value (parameter No. 28) is too small.	Increase the torque limit value.
						3. Start not allowed because of torque shortage due to power supply voltage drop.	1. Review the power supply capacity. 2. Use servo motor that provides larger output.
						4. Position control gain 1 (parameter No. 6) value is small.	Increase set value and adjust to ensure proper operation.
						5. Servo motor shaft was rotated by external force.	1. When torque is limited, increase the limit value. 2. Reduce load. 3. Use servo motor that provides larger output.
						6. Machine struck something.	1. Review operation pattern. 2. Install limit switches.
						7. Encoder faulty.	Change the servo motor.
						8. Wrong connection of servo motor. Servo amplifier's output terminals U, V, W do not match servo motor's input terminals U, V, W.	Connect correctly.
A. 8E	0	0	0	RS-232C alarm	Communication fault occurred between servo amplifier and personal computer.	1. Communication connector is disconnected.	Connect correctly.
						2. Communication cable faulty. (Wire breakage or short)	Repair or change cable.
						3. Personal computer faulty.	Change personal computer.
8888	0	0	0	Watchdog	CPU, parts faulty	Fault of parts in servo amplifier	Change servo amplifier.
<div style="border: 1px solid black; padding: 5px; margin: 5px 0;"> <p style="text-align: center;">— Checking method —</p> <p>Alarm (8888) occurs if power is switched on after CN1A, CN1B, and CN3 connectors are disconnected.</p> </div>							

## 8. TROUBLESHOOTING

### 8-2-3 Warnings

If a warning occurs, the servo amplifier does not go into a servo off status. However, if operation is continued in the warning status, an alarm may occur or proper operation not performed. Eliminate the cause of the warning according to this section. Use the optional set-up software to refer to the cause of warning.

Display	Name	Definition	Cause	Action
A. 92	Open battery cable warning	Absolute position detection system battery voltage is low.	1. Battery cable is open.	Repair cable or change battery.
			2. Battery voltage dropped to 2.8V or less.	Change battery.
A. 96	Zero setting error	1. For incremental, return to origin point could not be performed. 2. For absolute position detection system, origin point setting could not be performed.	1. Command pulses were input after droop pulses had been cleared.	Make provisions so that command pulses are not input after droop pulses are cleared.
			2. Droop pulses remaining are greater than in-position range setting.	
			3. Creep speed is high.	Reduce creep speed.
A. 9F	Battery warning	Absolute position detection system battery voltage is low.	Battery voltage dropped to 3.2V or less.	Change battery.
A. E0	Excessive regenerative load warning	There is a possibility that regenerative power may exceed permissible regenerative power of built-in regenerative brake resistor or regenerative brake option.	Regenerative power increased to 85% or more of permissible regenerative power of built-in regenerative brake resistor or regenerative brake option.  <div style="border: 1px solid black; padding: 5px; width: fit-content;">                     — Checking method —                      Call the status display and check regenerative load ratio.                 </div>	1. Reduce frequency of positioning. 2. Change regenerative brake option for the one with larger capacity. 3. Reduce load.
A. E1	Overload warning	There is a possibility that overload alarm 1 or 2 may occur.	Load increased to 85% or more of overload alarm 1 or 2 occurrence level.  <div style="border: 1px solid black; padding: 5px; width: fit-content;">                     — Cause, checking method —                      Refer to A. 50, 51.                 </div>	Refer to A. 50, 51.
A. E3	Absolute position counter warning	Absolute position encoder pulses faulty.	1. Noise entered the encoder.	Take noise suppression measures.
			2. Encoder faulty.	Change servo motor.
A. E5	ABS time-out warning	Absolute position data transfer fault	1. Programmable controller's ladder program error	Correct program.
			2. Mis-wiring of CN1B-9 pin, CN1B-6 pin	Connect correctly.
A. E6	Servo emergency stop	EMG-SG are open.	External emergency stop was made valid. (EMG-SG were opened.)	After ensuring safety, reset emergency stop.
A. E9	Main circuit off warning	Servo on signal (SON) was switched on with main circuit power off.	Servo on signal (SON) was switched on with main circuit power off.	Switch on main circuit power.
A. EA	ABS servo on warning	Servo on signal (SON) was not switched on within 1s after servo amplifier went into absolute position data transfer mode.	1. Programmable controller's ladder program error	Correct program
			2. Mis-wiring of SON signal	Connect correctly.

# CHAPTER 9

## CHARACTERISTICS

---

This chapter provides various characteristics and data of the servo.

- 9-1 Overload protection characteristics
- 9-2 Losses generated in the servo amplifier
- 9-3 Electromagnetic brake characteristics
- 9-4 Dynamic brake characteristics
- 9-5 Vibration rank

<b>INTRODUCTION</b>	<b>CHAPTER 1</b>
<b>OPERATION</b>	<b>CHAPTER 2</b>
<b>WIRING</b>	<b>CHAPTER 3</b>
<b>INSTALLATION</b>	<b>CHAPTER 4</b>
<b>ABSOLUTE POSITION DETECTION SYSTEM</b>	<b>CHAPTER 5</b>
<b>OPTIONS AND AUXILIARY EQUIPMENT</b>	<b>CHAPTER 6</b>
<b>INSPECTION</b>	<b>CHAPTER 7</b>
<b>TROUBLESHOOTING</b>	<b>CHAPTER 8</b>
<b>CHARACTERISTICS</b>	<b>CHAPTER 9</b>
<b>SPECIFICATIONS</b>	<b>CHAPTER 10</b>
<b>SELECTION</b>	<b>CHAPTER 11</b>

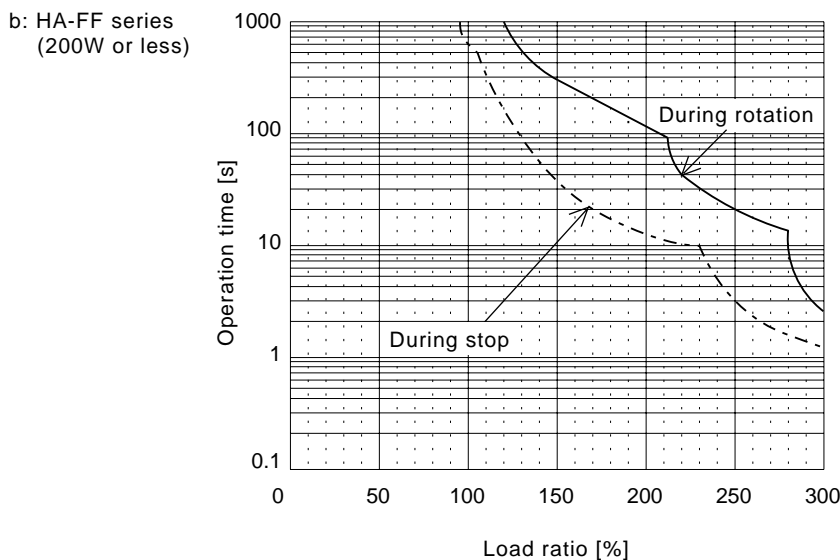
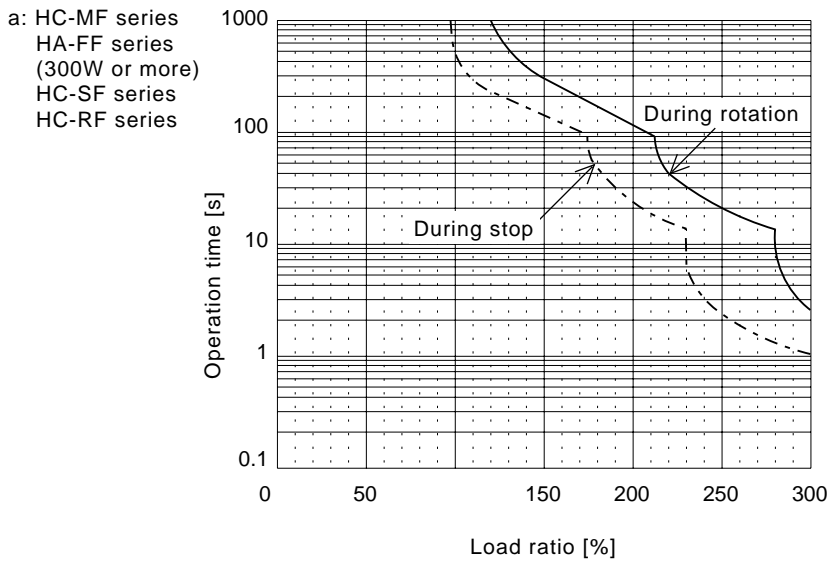
# 9.CHARACTERISTICS

## 9-1 Overload protection characteristics

An electronic thermal relay is built in the servo amplifier to protect the servo motor and servo amplifier from overloads. The operation characteristics of the electronic thermal relay are shown below. Overload 1 alarm (A. 50) occurs if overload operation performed is above the electronic thermal relay protection curve shown below. Overload 2 alarm (A. 51) occurs if the maximum current flew continuously for several seconds due to machine collision, etc. Use the equipment on the left-hand side area of the continuous or broken line in the graph.

In a machine like the one for vertical lift application where unbalanced torque will be produced, it is recommended to use the machine so that the unbalanced torque is 70% or less of the rated torque.

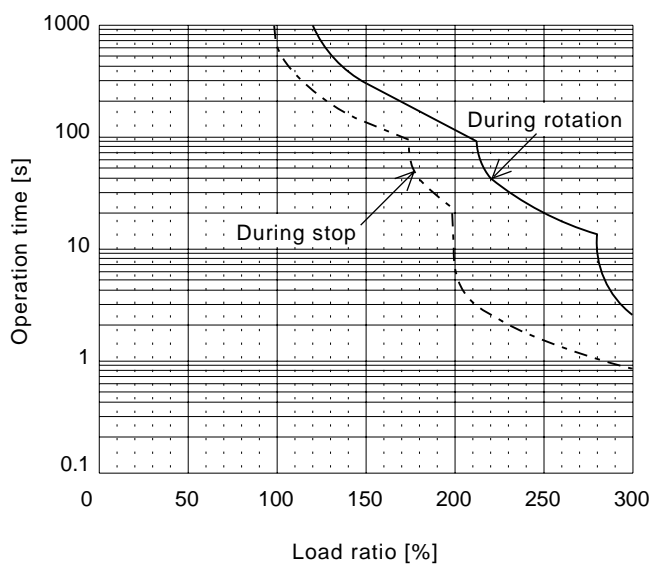
(1) MR—J2—10A to MR—J2—100A



# 9.CHARACTERISTICS

(2) MR—J2—200A and MR—J2—350A

HC-SF Series  
HC-RF Series  
HC-UF Series



# 9.CHARACTERISTICS

## 9-2 Losses generated in the servo amplifier

(1) Amount of heat generated by the servo amplifier

Table 9-1 indicates servo amplifiers' power supply capacities and losses generated under rated load. For thermal design of an enclosure, use the values in Table 9-1 in consideration for the worst operating conditions. The actual amount of generated heat will be intermediate between values at rated torque and zero torque according to the duty used during operation. When the servo motor is run at less than the maximum speed, the power supply capacity will be smaller than the value in the table, but the servo amplifier's generated heat will not change.

**Table 9-1 Power Supply Capacity and Generated Heat Per Servo Amplifier at Rated Output**

Servo Amplifier	Servo Motor	(Note 1) Power Supply Capacity [kVA]	(Note 2) Servo Amplifier-Generated Heat		Area Required for Heat Dissipation	
			At rated torque [W]	With servo off [W]	[m <sup>2</sup> ]	[ft <sup>2</sup> ]
MR-J2-10A(1)	HC-MF053-13	0.3	25	15	0.5	5.4
	HA-FF053-13	0.3	25	15	0.5	5.4
	HC-UF13	0.3	25	15	0.5	5.4
MR-J2-20A(1)	HC-MF23	0.5	25	15	0.5	5.4
	HA-FF23	0.5	25	15	0.5	5.4
	HC-UF23	0.5	25	15	0.5	5.4
MR-J2-40A(1)	HC-MF43	0.9	35	15	0.7	7.5
	HA-FF33	0.7	35	15	0.7	7.5
	HA-FF43	0.9	35	15	0.7	7.5
	HC-UF43	0.9	35	15	0.7	7.5
MR-J2-60A	HA-FF63	1.1	40	15	0.8	8.6
	HC-SF52	1.0	40	15	0.8	8.6
	HC-SF53	1.0	40	15	1.0	10.8
MR-J2-70A	HC-MF73	1.3	50	15	1.0	10.8
	HC-UF72-73	1.3	50	15	1.0	10.8
MR-J2-100A	HC-SF81	1.7	50	15	1.0	10.8
	HC-SF102-103	1.7	50	15	1.0	10.8
MR-J2-200A	HC-SF121	2.1	90	20	1.8	19.4
	HC-SF201	3.5	90	20	1.8	19.4
	HC-SF152-153	2.5	90	20	1.8	19.4
	HC-SF202-203	3.5	90	20	1.8	19.4
	HC-RF103	1.7	90	20	1.8	19.4
	HC-RF153	2.5	90	20	1.8	19.4
	HC-UF152	2.5	90	20	1.8	19.4
MR-J2-350A	HC-SF301	4.8	120	20	2.7	29.1
	HC-SF352-353	5.5	130	20	2.7	29.1
	HC-RF203	3.5	90	20	1.8	19.4
	HC-UF202	3.5	90	20	1.8	19.4

- Note: 1. Note that the power supply capacity will vary according to the power supply impedance.  
 2. Heat generated during regeneration is not included in the servo amplifier-generated heat. To calculate heat generated by the regenerative brake option, use Equation 6-1 in Section 6-1-1.



# 9.CHARACTERISTICS

## (2) Heat dissipation area for enclosed servo amplifier

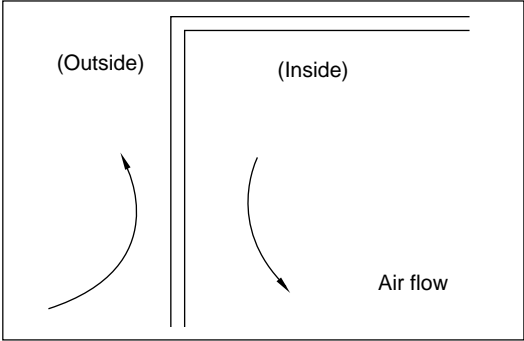
The enclosed control box (hereafter called the control box) which will contain the servo amplifier should be designed to ensure that its temperature rise is within +10°C at the ambient temperature of 40°C. (With a 5°C (41°F) safety margin, the system should operate within a maximum 55°C (131°F) limit.) The necessary enclosure heat dissipation area can be calculated by Equation 9-1:

$$A = \frac{P}{K \cdot \Delta T} \dots\dots\dots (9-1)$$

where, A: Heat dissipation area [m<sup>2</sup>]  
 P: Loss generated in the control box [W]  
 ΔT: Difference between internal and ambient temperatures [°C]

K: Heat dissipation coefficient [5 to 6]  
 When calculating the heat dissipation area with Equation 9-1, assume that P is the sum of all losses generated in the enclosure. Refer to Table 9-1 for heat generated by the servo amplifier. "A" indicates the effective area for heat dissipation, but if the enclosure is directly installed on an insulated wall, that extra amount must be added to the enclosure's surface area. The required heat dissipation area will vary with the conditions in the enclosure. If convection in the enclosure is poor and heat builds up, effective heat dissipation will not be possible. Therefore, arrangement of the equipment in the enclosure and the use of a fan should be considered.

Table 9-1 lists the enclosure dissipation area for each servo amplifier when the servo amplifier is operated at the ambient temperature of 40°C (104°F) under rated load.



**Fig. 9-1 Temperature Distribution in Enclosure**

When air flows along the outer wall of the enclosure, effective heat exchange will be possible, because the temperature slope inside and outside the enclosure will be steeper.

# 9.CHARACTERISTICS

## 9-3 Electromagnetic brake characteristics



### CAUTION

The electromagnetic brake is designed to hold a load. Do not use it for braking.

The characteristics of the electromagnetic brake provided for the servo motor with electromagnetic brake are indicated below:

Though the brake lining may rattle during low-speed operation, it poses no functional problem.

Though the brake lining may rattle during operation, it poses no functional problem. A leakage magnetic flux will occur at the shaft end of the servo motor equipped with electromagnetic brake.

### (1) Characteristics

**Table 9-2 Electromagnetic Brake Characteristics**

Servo Motor		HC-MF Series			HA-FF Series			HC-SF Series		HC-RF Series	
		053B 13B	23B 43B	73B	053B 13B	23B 33B	43B 63B	81B 52B to 152B 53B to 153B	121B to 301B 202B to 352B 202B-352B	103B to 203B	
(Note 1)	Type	Spring-loaded safety brake									
(Note 4)	Rated voltage	24VDC									
Rated current at 20°C [A]		0.26	0.33	0.42	0.22	0.31	0.46	0.8	1.4	0.8	
Excitation coil resistance at 20°C [Ω]		91	73	57	111	78	52	29	16.8	30	
Capacity [W]		6.3	7.9	10	7	7.4	11	19	34	19	
ON current [A]		0.18	0.18	0.2	0.15	0.2	0.3	0.2	0.4	0.25	
OFF current [A]		0.06	0.11	0.12	0.06	0.06	0.1	0.08	0.2	0.085	
Static friction torque	[N•m]	0.32	1.3	2.4	0.39	1.18	2.3	8.3	43.1	6.8	
	[oz•in]	45.3	184.2	340	55.3	167	326	1176	6108	964	
(Note 2) Release delay time [S]		0.03	0.03	0.03	0.03	0.03	0.03	0.04	0.1	0.03	
Braking delay time (Note 2) [s]	AC off (Fig. a)	0.08	0.1	0.12	0.08	0.1	0.12	0.12	0.12	0.12	
	DC off (Fig.s b, c)	0.01	0.02	0.03	0.01	0.03	0.03	0.03	0.03	0.03	
Permissible braking work	Per braking	[J]	5.6	22.0	64.0	3.9	18.0	46.0	400	4500	400
		[oz•in]	793.6	3117.6	9069.3	552.7	2550.7	6518.6	56683.3	637687.1	56683.3
	Per hour	[J]	56	220	640	39	180	460	4000	45000	4000
		[oz•in]	7936	31176	90693	5527	25507	65186	566833	6376871	566833
Brake looseness at servo motor shaft [degrees]		0.19 to 2.5	0.12 to 1.2	0.1 to 0.9	0.3 to 3.5	0.2 to 2.0	0.2 to 1.3	0.2 to 0.6	0.2 to 0.6	0.2 to 0.6	
Brake life (Note 3)	Number of braking cycles [times]		20000	20000	20000	30000	30000	30000	20000	20000	20000
	Work per braking	[J]	4	15	32	4	18	47	200	100	200
		[oz•in]	567	2126	4535	567	2551	6660	28342	141708	28342

## 9.CHARACTERISTICS

Servo Motor		HC-UF Series					
		13B	23B 43B	73B	72B 152B	202B	
(Note 1)	Type	Spring-loaded safety brake					
(Note 4)	Rated voltage	24V <sup>0</sup> <sub>-10%</sub> DC					
Rated current at 20°C [A]		0.26	0.33	0.42	0.8	1.4	
Excitation coil resistance at 20°C [Ω]		91	73	57	29	16.8	
Capacity [W]		6.3	7.9	10	19	34	
ON current [A]		0.18	0.18	0.2	0.2	0.4	
OFF current [A]		0.06	0.11	0.12	0.08	0.2	
Static friction torque	[N•m]	0.32	1.3	2.4	8.3	43.1	
	[oz•in]	45	184	340	1176	6108	
(Note 2)	Release delay time [S]	0.03	0.03	0.03	0.04	0.1	
Braking delay time (Note 2) [s]	AC off (Fig. a)	0.08	0.1	0.12	0.12	0.12	
	DC off (Fig.s b, c)	0.01	0.02	0.03	0.03	0.03	
Permissible braking work	Per braking	[J]	5.6	22	64	400	4500
		[oz•in]	793.6	3117.6	9069.3	56683.3	637687.1
	Per hour	[J]	56	220	640	4000	45000
		[oz•in]	7936	31176	90693	566833	6376871
Brake looseness at servo motor shaft [degrees]		0.19 to 2.5	0.12 to 1.2	0.1 to 0.9	0.2 to 0.6	0.2 to 0.6	
Brake life (Note 3)	Number of braking cycles [times]		20000	20000	20000	20000	20000
	Work per braking	[J]	4	15	32	200	1000
		[oz•in]	567	2126	4535	28342	141708

- Note: 1. There is no manual release mechanism. When it is necessary to hand-turn the servo motor shaft for machine centering, etc., use a separate 24VDC power supply to release the brake electrically.
2. The value for initial ON gap at 20°C.
3. The brake gap will increase as the brake lining wears, but the gap is not adjustable. The brake life indicated is the number of braking cycles after which adjustment will be required.
4. 24VDC of the internal power output for interface (VDD) cannot be used. Always use a separate power supply.

## 9.CHARACTERISTICS

### (2) Electromagnetic brake power supply

24VDC of the internal power output for interface (VDD) cannot be used. Prepare the following power supply for use with the electromagnetic brake only. Examples of connection of the brake exciting power supply are shown in Fig. 9-3 (a) to (c). (a) is for AC off, and (b) and (c) for DC off. When DC is switched off, the braking delay time will be shortened, but a surge absorber must be installed on the brake terminal. For the selection of the surge absorber, refer to Section 6-2-5.

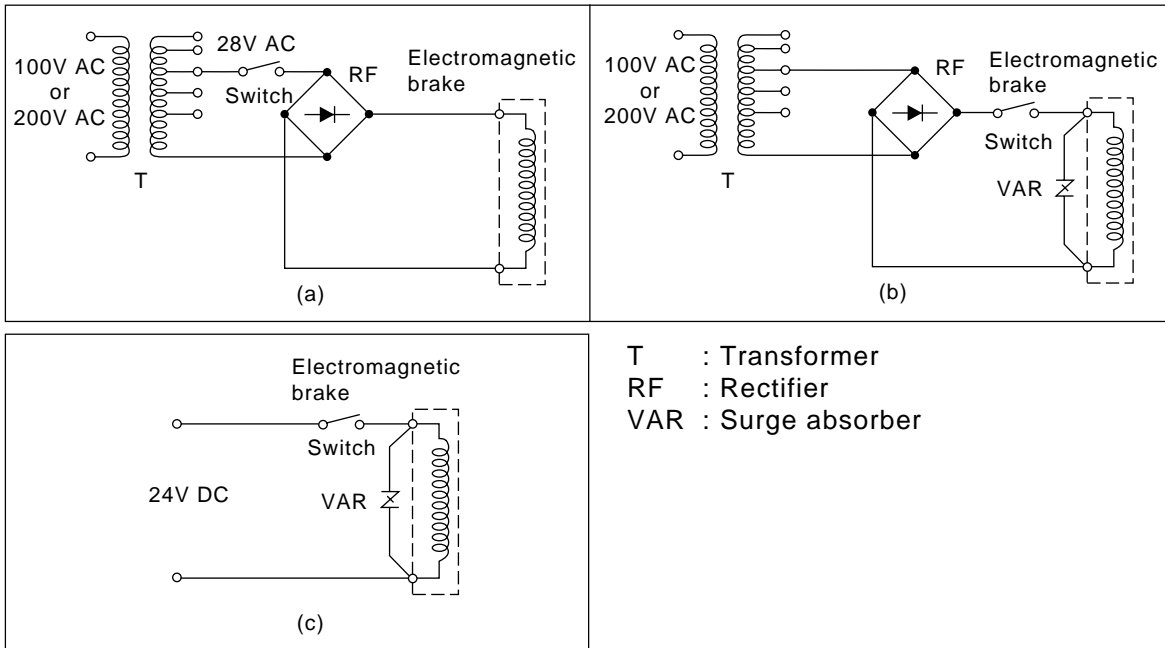


Fig. 9-2 Connection Examples

### (3) Coasting distance

At an emergency stop, the servo motor will decelerate to a stop in the pattern shown in Fig. 9-4. Here, the maximum coasting distance (during fast feed),  $L_{max}$ , will be the area shown with the diagonal line in the figure and can be calculated approximately with Equation 9-2. The effect of the load torque is greater near the stopping area. When the load torque is large, the servo motor will stop faster than the value obtained in the equation.

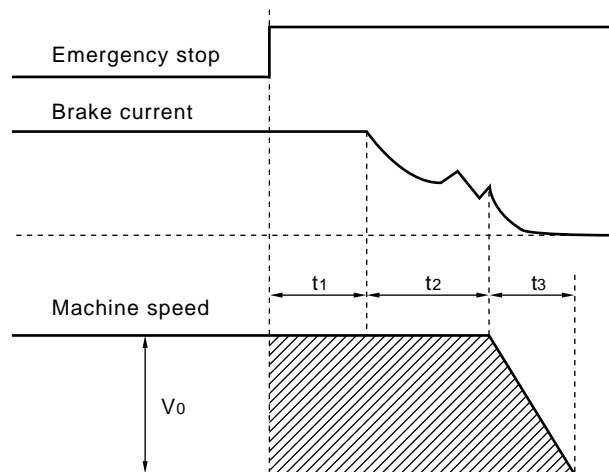


Fig. 9-3 Coasting Distance at Emergency Stop

## 9.CHARACTERISTICS

---

$$L_{\max} = \frac{V_o}{60} \cdot \left( t_1 + t_2 + \frac{t_3}{2} \right) \dots\dots\dots (9-2)$$

Where,

- L<sub>max</sub>: Maximum coasting distance [mm]
- V<sub>o</sub>: Machine's fast feed speed [mm/min]
- t<sub>1</sub>: Delay time of control section [s]
- t<sub>2</sub>: Braking delay time of brake (Note) [s]
- t<sub>3</sub>: Braking time [s]

$$t_3 = \frac{(J_L + J_M) \cdot N_o}{9.55 \times 10^4 \cdot (T_L + 0.8T_B)}$$

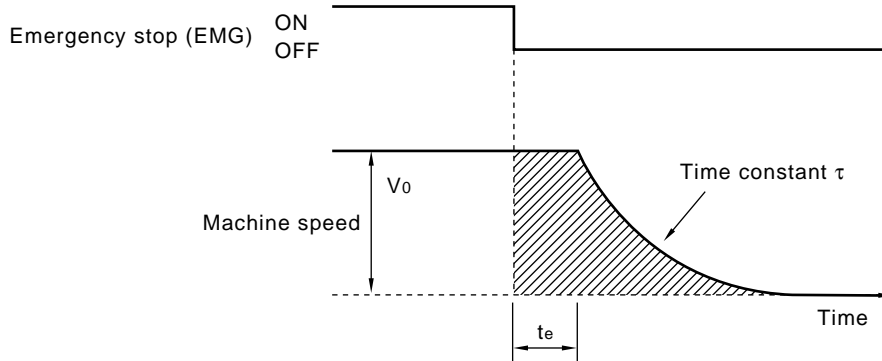
- J<sub>L</sub> : Load inertia moment converted into equivalent value on servo motor shaft [kg • cm<sup>2</sup>]
- J<sub>M</sub> : Servo motor inertia moment [kg • cm<sup>2</sup>]
- N<sub>o</sub> : Servomotor speed during fast feed [r/min]
- T<sub>L</sub> : Load torque converted into equivalent value on servo motor shaft [N • m]
- T<sub>B</sub> : Brake static friction torque (Note) [N • m]

Note: t<sub>2</sub> and T<sub>B</sub> are the values noted in Table 9-2 Characteristics. J<sub>L</sub> is the machine's inertia moment at the servo motor shaft.

# 9.CHARACTERISTICS

## 9-4 Dynamic brake characteristics

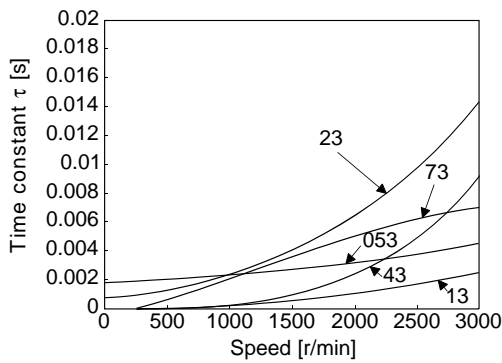
When an alarm, emergency stop or power failure occurs, the dynamic brake is operated to bring the servo motor to a sudden stop. Fig. 9-5 shows the pattern in which the servo motor comes to a stop when the dynamic brake is operated. Use Equation 9-3 to calculate an approximate coasting distance to a stop. The dynamic brake time constant  $\tau$  varies with the servo motor and machine operation speeds as indicated in Table 9-3 and as shown in Fig. 9-6 to Fig. 9-12.



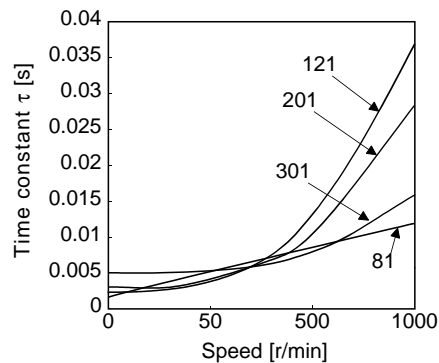
**Fig. 9-4 Dynamic Brake Operation Diagram**

$$L_{max} = \frac{V_0}{60} \cdot \left\{ t_e + \tau \left( 1 + \frac{J_L}{J_M} \right) \right\} \dots\dots\dots (9-3)$$

- $L_{max}$  : Maximum coasting distance [mm][in]
- $V_0$  : Machine rapid feedrate [mm/min][in/min]
- $J_M$  : Servo motor inertial moment [kg·cm<sup>2</sup>][oz·in<sup>2</sup>]
- $J_L$  : Load inertia moment converted into equivalent value on servo motor shaft [kg·cm<sup>2</sup>][oz·in<sup>2</sup>]
- $\tau$  : Brake time constant (Fig. 9-6 to 9-12 • Table 9-3) [s]
- $t_e$  : Delay time of control section (Fig. 9-5) [s]  
(There is internal relay delay time of about 30ms.)

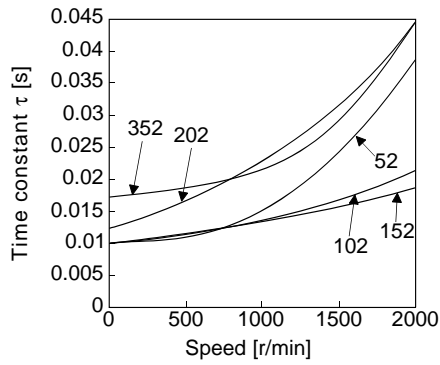


**Fig. 9-5 HC-MF Dynamic Brake Time Constant**

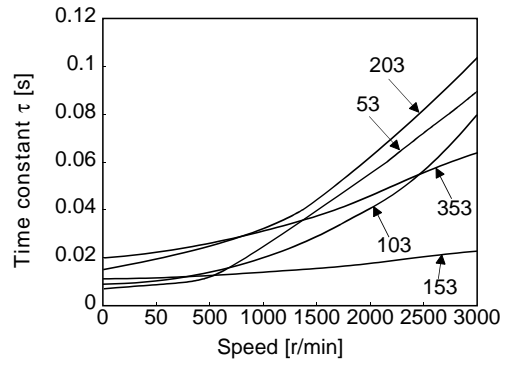


**Fig. 9-6 HC-SF1000r/min Dynamic Brake Time Constant**

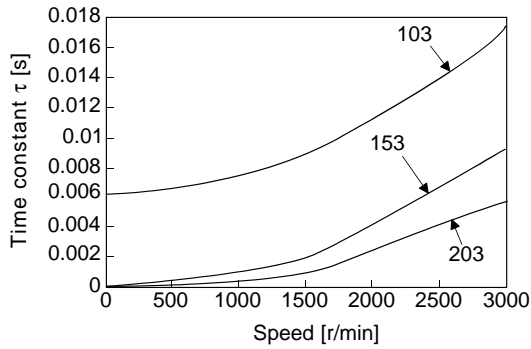
# 9.CHARACTERISTICS



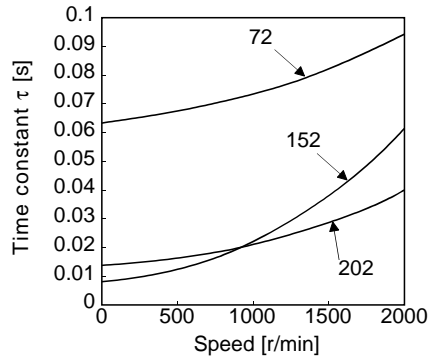
**Fig. 9-7 HC-SF2000r/min Dynamic Brake Time Constant**



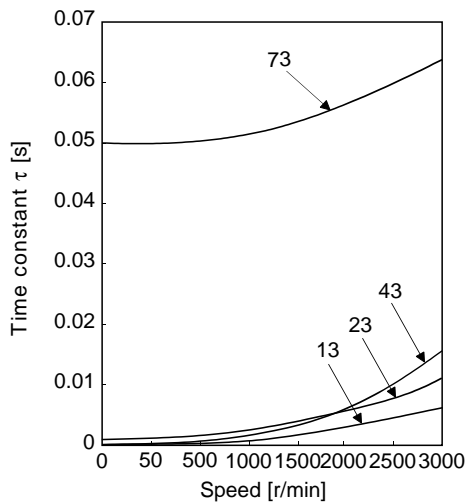
**Fig. 9-8 HC-SF3000r/min Dynamic Brake Time Constant**



**Fig. 9-9 HC-RF Dynamic Brake Time Constant**



**Fig. 9-10 HC-UF2000r/min Dynamic Brake Time Constant**



**Fig. 9-11 HC-UF3000r/min Dynamic Brake Time Constant**

**Table 9-3 HA-FF Dynamic Brake Time Constant**

Servo Motor	Brake Time Constant $\tau$ [s]
HA—FF053 · 13	0.02
HA—FF23	0.05
HA—FF33	0.07
HA—FF43	0.09
HA—FF63	0.12

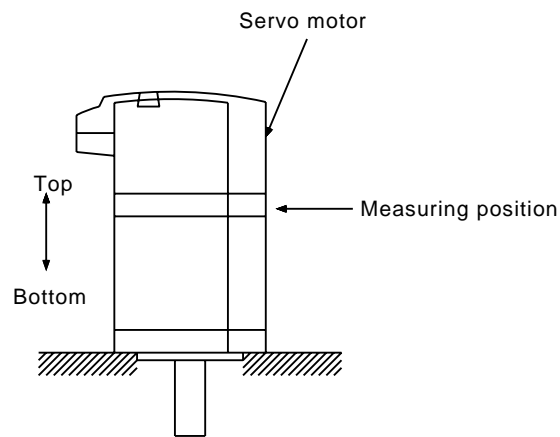
## 9.CHARACTERISTICS

Use the dynamic brake at the load inertia moment indicated on the right. If the load inertia moment is higher than this value, the built-in dynamic brake may burn. If there is a possibility that the load inertia moment may exceed, contact Mitsubishi.

Servo Amplifier	Load Inertia Moment Ratio [times]
MR—J2—10A to MR—J2—200A MR—J2—10A1 to MR—J2—40A1	30
MR—J2—350A	16

### 9-5 Vibration rank

The vibration rank of the servo motor is V-10 at the rated speed. Measure vibration in the following position with the servo motor installed as shown below.



Servo Motor Vibration Measuring Conditions



# CHAPTER 10

## SPECIFICATIONS

---

This chapter gives the specifications of the servo.

- 10-1 Standard specifications
- 10-2 Torque characteristics
- 10-3 Servo motors with reduction gears
- 10-4 Servo motors with special shafts
- 10-5 Outline dimension drawings
  - 10-5-1 Servo amplifiers
  - 10-5-2 Servo motors
  - 10-5-3 Servo motors (in inches)
  - 10-5-4 Cable side plugs

<b>INTRODUCTION</b>	<b>CHAPTER 1</b>
<b>OPERATION</b>	<b>CHAPTER 2</b>
<b>WIRING</b>	<b>CHAPTER 3</b>
<b>INSTALLATION</b>	<b>CHAPTER 4</b>
<b>ABSOLUTE POSITION DETECTION SYSTEM</b>	<b>CHAPTER 5</b>
<b>OPTIONS AND AUXILIARY EQUIPMENT</b>	<b>CHAPTER 6</b>
<b>INSPECTION</b>	<b>CHAPTER 7</b>
<b>TROUBLESHOOTING</b>	<b>CHAPTER 8</b>
<b>CHARACTERISTICS</b>	<b>CHAPTER 9</b>
<b>SPECIFICATIONS</b>	<b>CHAPTER 10</b>
<b>SELECTION</b>	<b>CHAPTER 11</b>

# 10. SPECIFICATIONS

## 10-1 Standard specifications

### (1) Servo amplifiers

Item		Servo Amplifier MR-J2-□										
		10A	20A	40A	60A	70A	100A	200A	350A	10A1	20A1	40A1
Power supply	Voltage/frequency	Three-phase 200 to 230VAC, 50/60Hz or single-phase 230VAC, 50/60Hz (Note1)					Three-phase 200 to 230VAC, 50/60Hz			Single-phase 100 to 120VAC, 50/60Hz		
	Permissible voltage fluctuation	Three-phase 200 to 230VAC: 170 to 253VAC Single-phase 230VAC: 207 to 253VAC					Three-phase 170 to 253VAC			Single-phase 85 to 127VAC		
	Permissible frequency fluctuation	±5%										
System		Sine-wave PWM control, current control system										
Dynamic brake		Built-in										
Protective functions		Overcurrent shut-off, regenerative overvoltage shut-off, overload shut-off (electronic thermal relay), servo motor overheat protection, encoder fault protection, regenerative fault protection, undervoltage, instantaneous power failure protection, overspeed protection, excessive error protection										
Speed frequency response		250Hz or more										
Torque limit input		0 to ±10VDC/max. current (except torque control mode)										
Position control specifications	Max. input pulse frequency	400kpps (for differential receiver), 200kpps (for open collector)										
	Command pulse multiplying factor	Electronic gear A/B, A, B: 1 to 32767, 1/50 < A/B < 50										
	In-position range setting	0~±10000 pulse										
Speed control specifications	Error excessive	±80 kpulse										
	Speed control range	Analog speed command 1: 1000, internal speed command 1:5000										
	Analog speed command input	DC0~±10V										
Torque control specifications	Speed fluctuation ratio	-0.03% or less (load fluctuation 0 to 100%) ±0.02% or less (power fluctuation ±10%) ±3% or less										
	Analog torque command input	DC0 to ±8V										
Structure [A]		Open (IP00)										
Environmental conditions		Refer to (1) in Section 4-1.										
Weight	[kg]	0.7	0.7	1.1	1.1	1.7	1.7	2.0	2.0	0.7	0.7	1.1
	[lb]	1.5	1.5	2.4	2.4	3.75	3.75	4.4	4.4	1.5	1.5	2.4

Note: The single-phase 230VAC power supply applies to a combination with the HC-MF/HA-FF series servo motor.

### (2) Servo motors

Item		Servo Motor	HC-MF Series (Ultra low inertia, small capacity)					HA-FF Series (Low inertia, middle capacity)					
			053	13	23	43	73	053	13	23	33	43	63
Applicable servo amplifier MR-J2-□			10A(1)		20A(1)	40A(1)	70A	10A(1)		20A(1)	40A(1)		60A
(Note 1) Continuous running duty	Rated output [kW]		0.05	0.1	0.2	0.4	0.75	0.05	0.1	0.2	0.3	0.4	0.6
	Rated torque [N·m]		0.16	0.32	0.64	1.3	2.4	0.16	0.32	0.64	0.95	1.3	1.9
	[oz·in]		22.7	45.3	90.7	184	340	22.7	45.3	90.7	135	184	269
Rated speed (Note 1) [r/min]			3000					3000					
Maximum speed [r/min]			4500					4000					
Permissible instantaneous speed [r/min]			5175					4600					
Maximum torque	[N·m]		0.48	0.95	1.9	3.8	7.2	0.48	0.95	1.9	2.9	3.8	5.7
	[oz·in]		68.0	135	269	538	1020	68.0	135	269	411	538	808
Power rate at continuous rated torque [kW/s]			13.47	34.13	41.8	116.55	94.43	4.0	10.2	11.7	18.1	17.2	30.1
(Note 7) Inertia moment	J[kg·cm <sup>2</sup> ]		0.019	0.03	0.088	0.143	0.6	0.063	0.095	0.35	0.50	0.98	1.2
	WK[oz·in]		0.104	0.16	0.48	0.78	3.28	0.344	0.52	1.91	2.73	5.36	6.56
Recommended ratio of load inertia moment to servo motor shaft inertia moment (Note 6)			30 times or less					10 times or less					
(Note 4) Regenerative brake duty [times/min]	Servo amplifier' built-in regenerative brake resistor		(Note 5)	(Note 5)	(Note 5)	1010	400	(Note 5)	(Note 5)	(Note 5)	320	150	120
	MR-RB032(30W)					3000	600				950	450	360
	MR-RB12(30W)					(Note 5)	2400				3200	1500	1200
(Note 3) Power supply capacity [kVA]		0.3	0.3	0.5	0.9	1.3	0.3	0.3	0.5	0.7	0.9	1.1	
Rated current [A]			0.85	1.5	2.8	5.1	0.6	1.1	1.3	1.9	2.5	3.6	
Maximum current [A]			2.6	5.0	9.0	18	1.8	3.3	3.9	5.7	7.5	10.8	
Speed/position detector			Encoder (resolution 8192 pulses/rev)										
Accessories			Encoder					Encoder, V ring					
Structure			Totally-enclosed, self-cooled (protection type: IP44 with the exception of through-shaft portion)(Note8)					Totally-enclosed, self-cooled (protection type: IP44)					
(Note 2) Environmental conditions			Refer to (1), Section 4-2.										
(Note 7) Weight	[kg]		0.4	0.53	0.99	1.45	3.0	1.3	1.5	2.3	2.6	4.2	4.8
	[lb]		0.88	1.17	2.18	3.2	6.6	2.87	3.31	5.07	5.73	9.26	10.6

## 10. SPECIFICATIONS

Servo Motor		HC-SF 1000r/min Series (Middle inertia, middle capacity)				HC-SF 2000r/min Series (Middle inertia, middle capacity)					
		81	121	201	301	52	102	152	202	352	
Applicable servo amplifier	MR-J2-□	100A	200A	200A	350A	60A	100A	200A	200A	350A	
(Note 1) Continuous running duty	Rated output [kW]	0.85	1.2	2.0	3.0	0.5	1.0	1.5	2.0	3.5	
	Rated torque	[N•m]	8.12	11.5	19.1	28.6	2.39	4.78	7.16	9.55	16.7
		[oz•in]	1151	1630	2707	4053	339	677	1015	1353	2367
(Note 1) Rated speed	[r/min]	1000				2000					
Maximum speed	[r/min]	1500	1200			3000			2500		
Permissible instantaneous speed	[r/min]	1725	1380			345			2850		
Maximum torque	[N•m]	24.4	34.4	57.3	85.9	7.16	14.4	21.6	28.5	50.1	
	[oz•in]	3458	4875	8120	12173	1015	2041	3061	4039	7100	
Power rate at continuous rated torque	[kW/s]	32.9	30.9	44.5	81.3	8.7	16.7	25.6	21.5	34.1	
(Note 7) Inertia moment	J [x10 <sup>-4</sup> kg•cm <sup>2</sup> ]	20.0	42.5	82	101	6.6	13.7	20.0	4.5	82.0	
	WK <sup>2</sup> [oz•in <sup>2</sup> ]	109	232	448	552	36.1	74.9	109	232	448	
(Note 6) Recommended ratio of load inertia moment to servo motor shaft inertia moment		15 times or less				15 times or less					
(Note 4) Regenerative brake duty [times/min]	Servo amplifier' built-in regenerative brake resistor	140	70	100	84	56	54	136	64	31	
	MR-RB032(30W)	220	110			165	80				
	MR-RB12(100W)	740	350			560	270				
	MR-RB32(300W)	2220	1040				810				
	MR-RB30(300W)			330	250			408	192	95	
MR-RB50(500W)			550	430			680	320	158		
(Note 3) Power supply capacity	[kVA]	1.5	2.1	3.5	4.8	1.0	1.7	2.5	3.5	5.5	
Rated current	[A]	5.1	7.1	9.6	16	3.2	6	9	11	17	
Maximum current	[A]	15.3	21.3	28.8	48	9.6	18	27	33	51	
Speed/position detector		Encoder (resolution : 16384 pulses/rev)				Encoder (resolution : 16384 pulses/rev)					
Accessories		Encoder•oil seal				Encoder•oil seal					
Structure		Totally-enclosed, self-cooled (protection type: IP65)				Totally-enclosed, self-cooled (protection type: IP65)					
(Note 2) Environmental conditions		Refer to (1), Section 4-2.				Refer to (1), Section 4-2.					
(Note 7) Weight	[kg]	9.0	12	19	23	5.0	7.0	9.0	12.0	19.0	
	[lb]	19.8	26.5	41.9	50.7	11.0	15.4	19.8	26.5	41.9	

# 10. SPECIFICATIONS

Servo Motor		HC-SF 3000r/min Series (Middle inertia, middle capacity)					HC-RF Series (Low inertia, small capacity)			
		53	103	153	(Note9) 203	(Note9) 353	103	153	203	
Applicable servo amplifier	MR-J2-□	60A	100A	200A	200A	350A	200A	200A	350A	
(Note 1) Continuous running duty	Rated output [kW]	0.5	1.0	1.5	2.0	3.5	1.0	1.5	2.0	
	Rated torque	[N•m]	1.59	3.18	4.78	6.37	11.1	3.18	4.78	6.37
		[oz•in]	225	451	677	903	1573	451	677	903
(Note 1) Rated speed	[r/min]	3000					3000			
Maximum speed	[r/min]	3000					4500			
Permissible instantaneous speed	[r/min]	3450					5175			
Maximum torque	[N•m]	4.77	9.55	14.3	19.1	33.4	7.95	11.9	15.9	
	[oz•in]	676	1353	2026	2707	4733	1127	1686	2253	
Power rate at continuous rated torque	[kW/s]	3.8	7.4	11.4	9.5	15.1	67.4	120	176	
(Note 7) Inertia moment	J [ $\times 10^{-4}$ kg•cm <sup>2</sup> ]	6.6	13.7	20.0	42.5	82.0	1.5	1.9	2.3	
	WK <sup>2</sup> [oz•in <sup>2</sup> ]	36.1	74.9	109.3	232.4	448.3	8.2	10.4	12.6	
(Note 6) Recommended ratio of load inertia moment to servo motor shaft inertia moment		15 times or less					5 times or less			
(Note 4) Regenerative brake duty [times/min]	Servo amplifier' built-in regenerative brake resistor	25	24	82	24	14	1090	860	710	
	MR-RB032(30W)	73	36							
	MR-RB12(100W)	250	120							
	MR-RB32(300W)		360							
	MR-RB30(300W)			250	70	42	3270	2580	2130	
	MR-RB50(500W)			410	110	70	5450	4300	3550	
(Note 3) Power supply capacity	[kVA]	1.0	1.7	2.5	3.5	5.5	1.8	2.5	3.5	
Rated current	[A]	3.2	5.3	8.6	10.4	16.4	6.1	8.8	14	
Maximum current	[A]	9.6	15.9	25.8	31.2	49.2	18.4	23.4	37	
Speed/position detector		Encoder (resolution : 16384 pulses/rev)					Encoder (resolution : 16384 pulses/rev)			
Accessories		Encoder•oil seal					Encoder•oil seal			
Structure		Totally-enclosed, self-cooled (protection type: IP65)					Totally-enclosed, self-cooled (protection type: IP65)			
(Note 2) Environmental conditions		Refer to (1), Section 4-2.					Refer to (1), Section 4-2.			
(Note 7) Weight	[kg]	5.0	7.0	9.0	12	19	3.9	5.0	6.2	
	[lb]	11.0	15.4	19.8	26.5	41.9	8.6	11.0	13.7	

## 10. SPECIFICATIONS

Servo Motor		HC-UF 2000r/min Series (Pancake type middle capacity)			HC-UF 3000r/min Series (Pancake type small capacity)				
		72	152	202	13	23	43	(Note9) 73	
Applicable servo amplifier	MR-J2-□	70A	200A	350A	10A	20A	40A	70A	
(Note 1) Continuous running duty	Rated output [kW]	0.75	1.5	2.0	0.1	0.2	0.4	0.75	
	Rated torque	[N•m]	3.58	7.16	9.55	0.32	0.64	1.3	2.4
		[oz•in]	507	1015	1353	45	91	184	340
(Note 1) Rated speed	[r/min]	2000			3000				
Maximum speed	[r/min]	3000			4500				
Permissible instantaneous speed	[r/min]	3450			5175				
Maximum torque	[N•m]	10.7	21.6	28.5	0.95	1.9	3.8	7.2	
	[oz•in]	1516	3061	4039	135	269	538	1020	
Power rate at continuous rated torque	[kW/s]	12.3	23.2	23.9	15.5	19.2	47.7	9.66	
(Note 7) Inertia moment	J [ $\times 10^{-4}$ kg•cm <sup>2</sup> ]	10.4	22.1	38.2	0.066	0.241	0.365	5.90	
	Wk <sup>2</sup> [oz•in <sup>2</sup> ]	56.9	120.8	208.9	0.4	1.3	2.0	32.3	
(Note 6) Recommended ratio of load inertia moment to servo motor shaft inertia moment		15 times or less			15 times or less				
(Note 4) Regenerative brake duty [times/min]	Servo amplifier' built-in regenerative brake resistor	53	124	68	(Note5)	(Note5)	410	41	
	MR-RB032(30W)	79					1230	62	
	MR-RB12(100W)	87					4106	206	
	MR-RB32(300W)	791							
	MR-RB30(300W)		372	203					
MR-RB50(500W)		620	338						
(Note 3) Power supply capacity	[kVA]	1.3	2.5	3.5	0.3	0.5	0.9	1.3	
Rated current	[A]	5.4	9.7	14	0.76	1.5	2.8	4.3	
Maximum current	[A]	16.2	29.1	42	2.5	4.95	9.24	12.9	
Speed/position detector		Encoder (resolution 16384 pulses/rev)			Encoder (resolution : 8192 pulses/rev)				
Accessories		Encoder•oil seal			Encoder•oil seal				
Structure		Totally-enclosed, self-cooled (protection type: IP65(Note9))			Totally-enclosed, self-cooled (protection type: IP65(Note9))				
(Note 2) Environmental conditions		Refer to (1), Section 4-2.			Refer to (1), Section 4-2.				
(Note 7) Weight	[kg]	8.0	11.0	16.0	0.8	1.5	1.7	5.0	
	[lb]	17.6	24.3	35.3	1.8	3.3	3.7	11.0	

- Note: 1. When the power supply voltage drops, we cannot guarantee the output and rated speed.  
2. When the equipment is to be used in places where it is subjected to oil and/or water, such as on machine field sites, optional features apply to the equipment. Please contact.  
3. The power supply capacity depends on the power supply impedance.  
4. The regenerative brake duty indicated is the permissible duty when the servo motor running without load at the rated speed is decelerated to a stop. When a load is connected, the value in the table is multiplied by  $1/(m + 1)$ , where  $m = \text{load inertia moment}/\text{motor inertia moment}$ . At the speed higher than the rated, the permissible number of times is in inverse proportion to the square of (running speed/rated speed). When the running speed varies frequently or when the regenerative mode continues as in vertical feed, calculate regenerative heat generated during operation. Provisions must be made to keep this generated heat below the permissible value.  
5. If the effective torque is within the rated torque range, there are no restrictions on the regenerative duty.  
6. If the load inertia moment ratio exceeds the indicated value, please consult us.  
7. When the servo motor is equipped with reduction gear or electromagnetic brake, refer to the corresponding outline dimension drawing. For the EN Standard- and UL/C-UL Standard-compliant models, please consult us.  
8. Except for the shaft-through portion and connector.  
9. HC-UF73, HC-SF203, and HC-SF353 may not be connected depending on the production period of the servo amplifier. For details, contact us.

# 10. SPECIFICATIONS

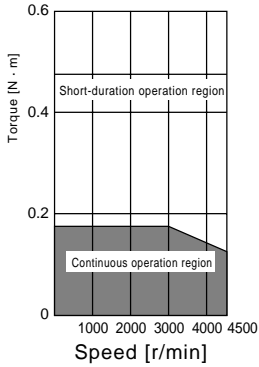
## 10-2 Torque characteristics



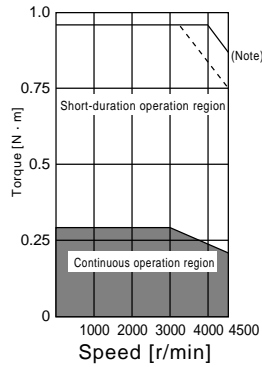
If load is applied at stop (during servo lock), 70% of the rated torque must not be exceeded.

### (1) HC-MF series

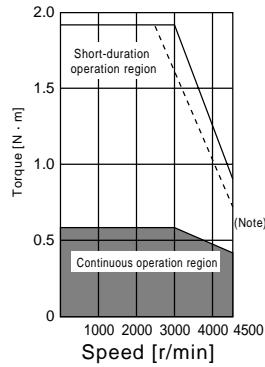
(HC-MF053)



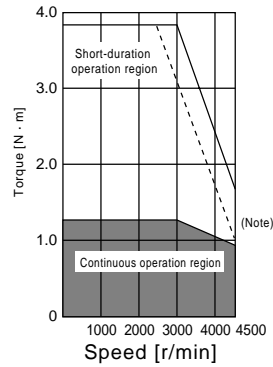
(HC-MF13)



(HC-MF23)

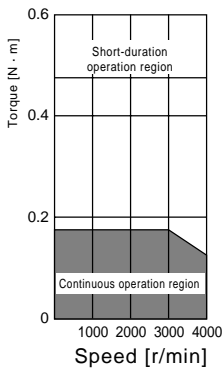


(HC-MF43)

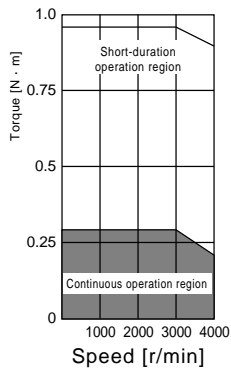


### (2) HA-FF series

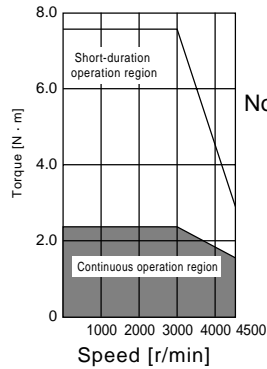
(HA-FF053)



(HA-FF13)

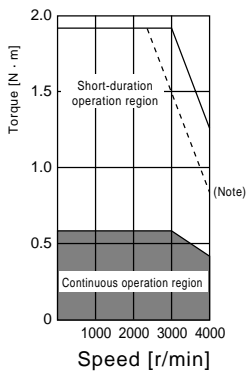


(HC-MF73)

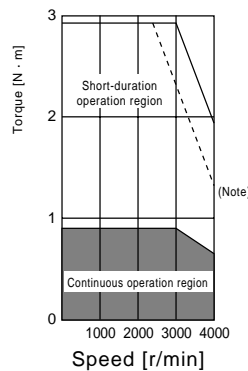


Note: The broken line indicates the torque characteristic of the servo motor used with the single-phase 100V power supply series servo amplifier.

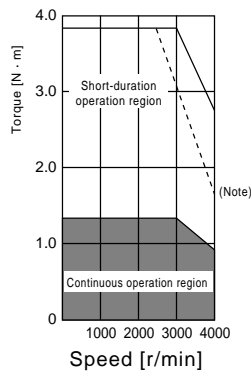
(HA-FF23)



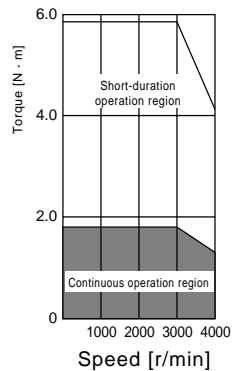
(HA-FF33)



(HA-FF43)



(HA-FF63)

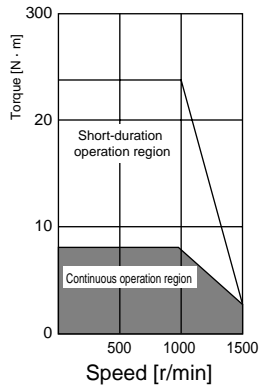


Note: The broken line indicates the torque characteristic of the servo motor used with the single-phase 100V power supply series servo amplifier.

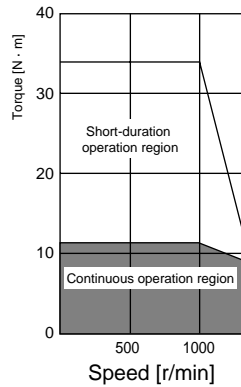
# 10. SPECIFICATIONS

## (3) HC-SF series

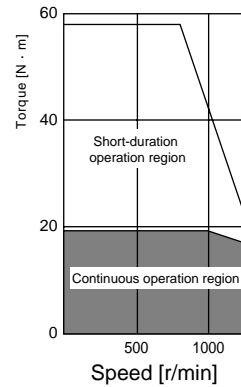
(HC-SF81)



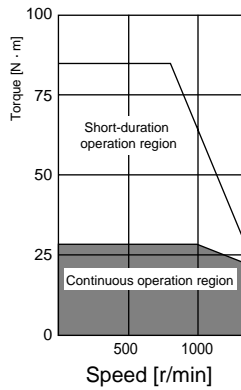
(HC-SF121)



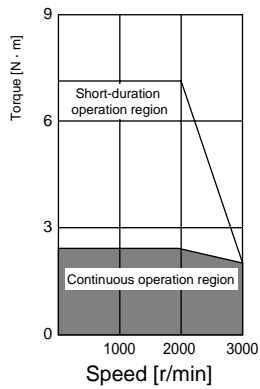
(HC-SF201)



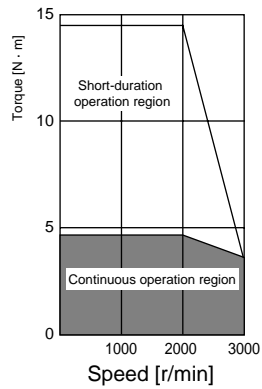
(HC-SF301)



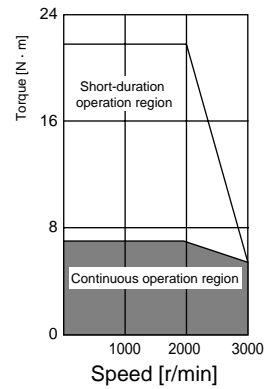
(HC-SF52)



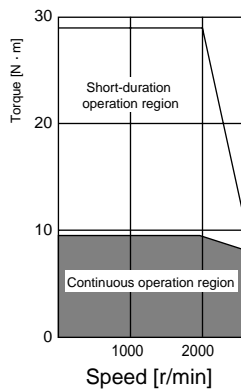
(HC-SF102)



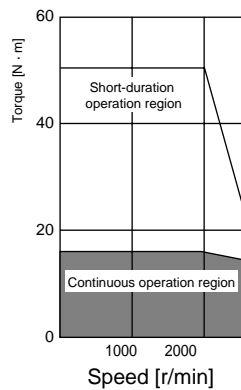
(HC-SF152)



(HC-SF202)

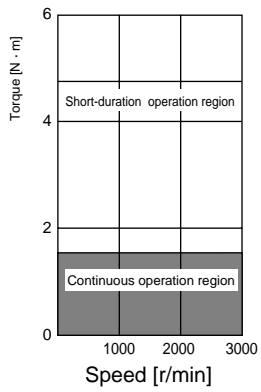


(HC-SF352)

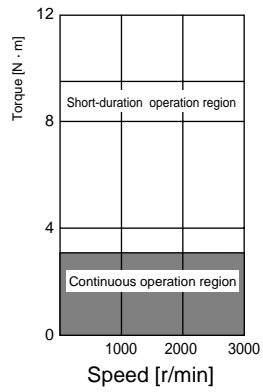


# 10. SPECIFICATIONS

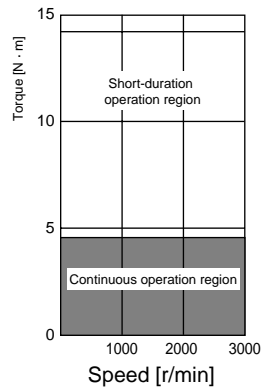
(HC-SF53)



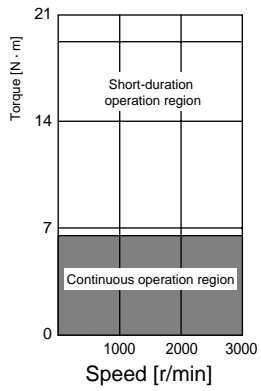
(HC-SF103)



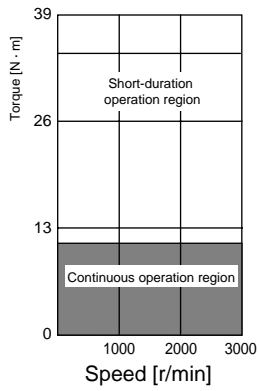
(HC-SF153)



(HC-SF203)

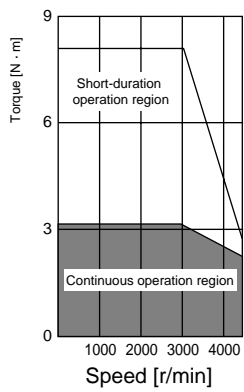


(HC-SF353)

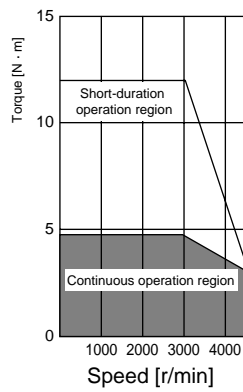


## (4) HC-RF series

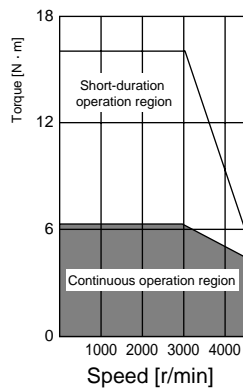
(HC-RF103)



(HC-RF153)



(HC-RF203)

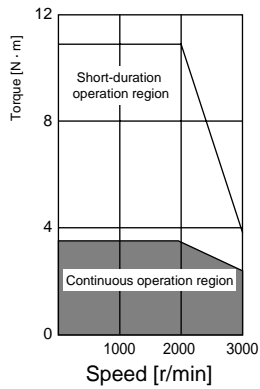




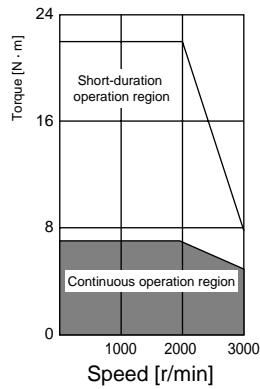
# 10. SPECIFICATIONS

## (5) HC-UF series

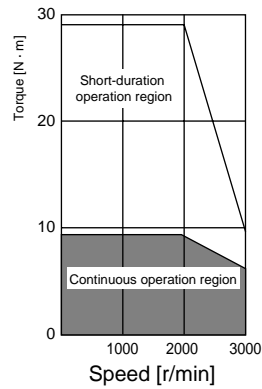
(HC-UF72)



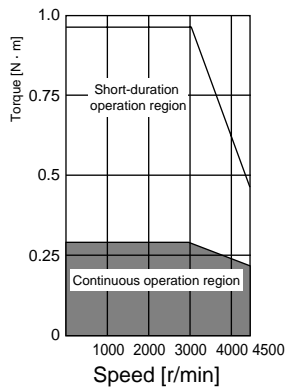
(HC-UF152)



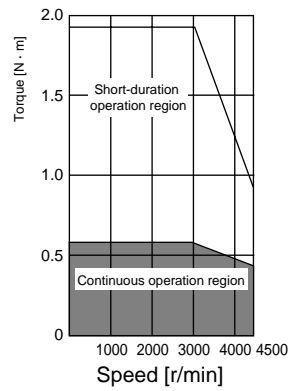
(HC-UF202)



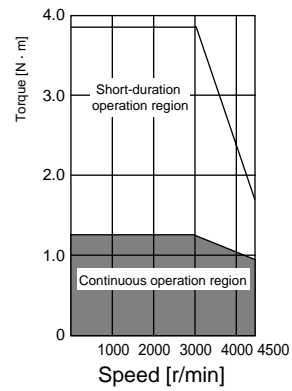
(HC-UF13)



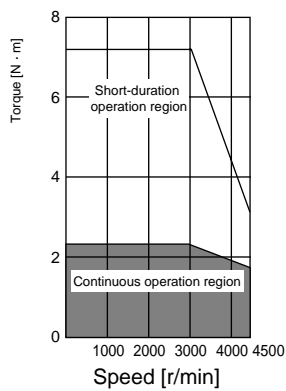
(HC-UF23)



(HC-UF43)



(HC-UF73)



# 10. SPECIFICATIONS

## 10-3 Servo motors with reduction gears

Servo motors are available with reduction gears designed for: 1) general industrial machines; and 2) precision applications.

Servo motors with electromagnetic brakes are also available.

### (1) Manufacturing range of servo motor with reduction gear

Servo motors with reduction gears that may be manufactured are indicated by symbols (G1 (H), G2) in the following table. G1 (H) and G2 are symbols appended to the servo motor models. (Refer to 2), (2) in Section 1-1.)

Reduction Gear Series Reduction ratio Servo motor	1) For General Industrial Machines											2) For Precision Applications								
	(Note) 1/5	1/6	(Note) 1/10	1/11	(Note) 1/12	1/17	(Note) 1/20	1/29	(Note) 1/30	1/35	1/43	1/59	1/5	1/9	1/10	1/15	1/20	1/25	1/29	1/45
HC-MF053□ to 73□	G1				G1		G1						G2	G2			G2		G2	
HA-FF053□	G1		G1					G1					G2		G2	G2		G2		
HA-FF13□	G1		G1					G1					G2		G2	G2		G2		G2
HA-FF23□	G1		G1					G1					G2		G2	G2	G2		G2	G2
HA-FF33□	G1		G1					G1					G2		G2		G2		G2	G2
HA-FF43□ • 63□	G1		G1					G1					G2	G2			G2		G2	G2
HC-SF52□ to 202□		G1 (H)		G1 (H)		G1 (H)		G1 (H)		G1 (H)	G1 (H)	G1 (H)	G2	G2			G2		G2	G2
HC-SF352□		G1 (H)		G1 (H)		G1 (H)		G1 (H)		G1 (H)	G1 (H)	G1 (H)	G2	G2			G2			
HC-RF103□ to 203□													G2	G2			G2		G2	G2

Note: Reduction ratios for general industrial machines are nominal values. For actual reduction ratios, refer to (2) and (3) in this section.

### (2) HC-MF series

Reduction Gear Series		For General Industrial Machines (HC-MF□G1)		For Precision Applications (HC-MF□G2)	
Mounting Method		Flange mounting			
Mounting direction		In any directions			
Lubrication	Recommended grease	Grease lubrication (Already packed)		Grease lubrication (Already packed)	
		50 • 100W Mobilplex 46 Mobil Oil	200 to 750W Mobiltac 81 Mobil Oil	LDR101BV American Oil Center Research	
Output shaft rotating direction		Same as the servo motor output shaft direction.			
With electromagnetic brake		Available			
Backlash		60 minutes or less at reduction gear output shaft		3 minutes or less at reduction gear output shaft	
Permissible load inertia moment ratio (when converting into the servo motor shaft)		25 times or less		25 times or less	
Permissible speed (at servo motor shaft)		4500 r/min			

The actual reduction ratios of the servo motors with reduction gears designed for general industrial machines are as listed below:

Servo Motor Nominal Reduction Ratio	HC-MF053(B)G1	HC-MF13(B)G1	HC-MF23(B)G1	HC-MF43(B)G1	HC-MF73(B)G1
1/5	9/44		19/96		1/5
1/12	49/576		25/288		525/6048
1/20	25/484		253/5000		625/12544

## 10. SPECIFICATIONS

### (3) HA-FF series

Reduction Gear		For General Industrial Machines (HA-FF□G1)		For Precision Applications (HA-FF□G2)	
Mounting Method		Flange mounting			
Mounting direction		In any directions			
Lubrication	Recommended greas	Grease lubrication (Already packed)		Grease lubrication (Already packed)	
		50 • 100W	200 to 600W	LDR101BJ American Oil Center Research	
		SUMICO LUBRICANT MOLY PS GREASE No.2	PYRONOC UNIVERSAL No.000 NIPPON PETRQLEUM		
Output shaft rotating direction		Servo motor shaft and reduction gear output shaft rotate in the same direction. For the HA-FF053G1 1/30 and HA-FF3G1 1/30, however, the servo motor shaft and reduction gear output shaft rotate in the opposite directions.		Servo motor shaft and reduction gear output-shaft rotate in the same direction.	
With electromagnetic brake		Available			
Backlash		40 minutes to 1.5°		Within 3 minutes	
Permissible load inertia moment ratio (when converting into the servo motor shaft)		5 times or less			
Permissible speed (at servo motor shaft)		3000 r/min			

The actual reduction ratios of the servo motors with reduction gears designed for general industrial machines are as listed below:

Nominal Reduction Ratio	Servo Motor					
	HA-FF053G1	HA-FF13G1	HA-FF23G1	HA-FF33G1	HA-FF43G1	HA-FF63G1
1/5	9/44		57/280	19/94		10/49
1/10	3/29		39/400	39/376		243/2401
1/30	144/4205		1/30	11/329		27/784

## 10. SPECIFICATIONS

### (4) HC-SF series

Reduction Gear Series		For General Industrial Machines (HC-SF□G1(H))	For Precision Applications (HC-SF□G2)
Mounting method		As in 1) in this section	Flange mounting
Mounting direction		As in 1) in this section	In any directions
Lubrication	Recommended grease	As in 1) in this section	Grease lubrication (Already packed)
		As in 2) in this section	LDR101BJ of American Oil Center Research make
Output shaft rotating direction		Opposite direction to the servo motor shaft	Same direction as the servo motor shaft
With electromagnetic brake		Available	
Backlash		40 minutes to 2° at reduction gear output shaft	3 minutes or less at reduction gear output shaft
Permissible load inertia moment ratio (when converting into the servo motor shaft)		4 times or less	5 times or less
Permissible speed (at servo motor shaft)		2000[r/min]	0.5 to 1.5kW:3000[r/min] 2 to 3.5kW:2500[r/min]

#### 1) Lubrication of reduction gears for general industrial machines

Oil lubrication cannot be used in applications where the servo motor will move. Specify grease lubrication.

For grease lubrication, the reduction gear is already grease-packed.

For oil lubrication, pack the reduction gear with oil on the customer side.

Mounting Direction Reduction gear model Reduction gear frame No.	Shaft in Any Direction		Shaft Horizontal		Shaft Downward		Shaft Upward	
	CNHM (leg type)	CNVM (flange type)	CHHM (leg type)	CHVM (flange type)	CVHM (leg type)	CVVM (flange type)	CWHM (leg type)	CWVM (flange type)
4105	Grease	Grease						
4115	Grease	Grease						
4135			(Note) Oil	(Note) Oil	(Note) Oil	(Note) Oil	Grease	Grease
4165			(Note) Oil	(Note) Oil	(Note) Oil	(Note) Oil	Grease	Grease
4175			Oil	Oil	Oil	Oil		

Note: Grease-lubricated type is also available.

The reduction gear frame numbers are as follows:

Servo Motor	Reduction Ratio						
	1/6	1/11	1/17	1/29	1/35	1/43	1/59
HC-SF52(B)G1 (H)	4105				4115		
HC-SF102(B)G1 (H)	4115					4135	4165
HC-SF152(B)G1 (H)	4115			4135		4165	
HC-SF202(B)G1 (H)	4115			4165			
HC-SF352(B)G1 (H)	4135			4165		4175	

## 10. SPECIFICATIONS

### 2) Recommended lubricants

#### a. Grease:

(Changing intervals: 20000 hours or 4 to 5 years)

#### b. Lubricating oil

Ambient Temperature °C	COSMO OIL	Nisseki Mitsubishi Oil	IDEMITSU KOSAN CO., LTD	GENERAL OIL	Showa Shell Sekiyu	ESSO OIL	Mobil OIL	Japan Energy
10 to 5	COSMO GEAR SE 68	BONNOC SP 68 DIAMOND GEAR LUBE SP 68	DAPHNE CE 68S DAPHNE SUPER GEAR OIL 68		Omala Oils 68	SPARTAN EP 68	Mobilgear 626 (ISO VG68)	JOMO. Reductus 68
0 to 35	COSMO GEAR SE 100, 150	BONNOC SP 100, 150 DIAMOND GEAR LUBE SP 100, 150	DAPHNE CE 100S,150S DAPHNE SUPER GEAR OIL 100, 150	GENERAL SP GEAROL 100, 150	Omala Oils 100, 150	SPARTAN EP150	Mobilgear 629 (ISO VG150)	JOMO. Reductus 100, 150
30 to 50	COSMO GEAR SE 200,320,460	BONNOC SP 200 to 460 DIAMOND GEAR LUBE SP 220 to 460	DAPHNE CE 220S to 460S	GENERAL SP GEAROL 200 to 260	Omala Oils 200 to 460	SPARTAN EP 220 to 460	Mobilgear 630 to 634 (ISO VG 220 to 460)	JOMO. Reductus 200 to 460

### Lubricating oil fill amount ( ℓ )

Reduction gear frame No.		4135	4165	4175
Fill amount	Horizontal type	0.7	1.4	1.9
	Vertical type	1.1	1.0	1.9

### (5) HC-RF series

Reduction Gear Series	For Precision Applications (HC-RF□G2)
Mounting method	Flange mounting
Mounting direction	In any directions
Lubrication	Grease lubrication (Already packed)
Recommended grease	LDR101BJ of American Oil Center Research make
Output shaft rotating direction	Same direction as the servo motor shaft
With electromagnetic brake	Available
Backlash	Within 3 minutes at reduction gear output shaft
Permissible load inertia moment ratio (when converting into the servo motor shaft)	5 times or less
Permissible speed (at servo motor shaft)	4000[r/min]

# 10. SPECIFICATIONS

## 10-4 Servo motors with special shafts

The standard shaft of the servo motor is straight without a keyway. Shafts with keyway and D cut are also available.

These shafts are not appropriate for applications where the servo motor is started and stopped frequently. Use a friction coupling or the like with such keys since we cannot guarantee such trouble as broken shafts due to loose keys.

Servo Motor Model	Shaft Shape	
	Keyway	D cut
HC—MF053 · 13		○
HC—MF23 to 73	(Note 1)○	
HA—FF053 · 13		○
HA—FF23 to 63	(Note 2)○	

Note: 1. With a key.  
2. Standard with a key. For shape, refer to Section 10-5-2.

Servo Motor Model	Shaft Shape	
	Keyway	D cut
HC—SF53 to 353 HC—SF53 to 352 HC—SF81 to 301	○	
HC—RF103 to 203	○	
HC—UF72 to 202	○	
HC—UF13		○
HC—UF23 to 73	(Note1)○	

### Machining Dimension Diagram

[Unit: mm]  
([Unit: in])

HC—MF23K to 73K      HC—UF23K to 73K

Section A-A

#### Variable Dimension List

Servo Motor Model	Variable Dimensions								
	S	R	Q	W	QK	QL	U	H	Y
HC—MF23K · 43K	14h6 (14)	30 (1.18)	27 (1.06)	5 (0.20)	20 (0.79)	3 (0.12)	3 (0.12)	5 (0.20)	M4 Depth 15 (0.59)
HC—MF73K	19h6 (19)	40 (1.57)	37 (1.46)	6 (0.24)	25 (0.98)	5 (0.20)	3.5 (0.14)	6 (0.24)	M5 Depth 20 (0.79)
HC—UF23K · 43K	14h6 (14)	30 (1.18)	23.5 (0.93)	5 (0.20)	20 (0.79)	3 (0.12)	3 (0.12)	5 (0.20)	M4 Depth 15 (0.59)
HC—UF73K	19h6 (19)	40 (1.57)	36.5 (1.44)	6 (0.24)	25 (0.98)	5 (0.20)	3.5 (0.14)	6 (0.24)	M5 Depth 20 (0.79)

# 10. SPECIFICATIONS

Keyway		[Unit: mm] ([Unit: in])							
	<b>Servo Motor Model</b>	<b>Variable Dimensions</b>							
		<b>S</b>	<b>R</b>	<b>Q</b>	<b>W</b>	<b>QK</b>	<b>QL</b>	<b>U</b>	<b>r</b>
	HC—SF81K HC—SF52K to 152K HC—SF53K to 153K	24h6 (0.94)	55 (2.17)	50 (1.97)	$8^{0}_{-0.036}$ (0.31)	36 (1.42)	5 (0.20)	$4^{+0.2}_{0}$ (0.16)	4 (0.16)
	HC—SF121K to 301K HC—SF202K to 352K HC—SF203K · 353K	35 (1.38)	79 (3.11)		$10^{0}_{-0.036}$ (0.39)	55 (2.17)	5 (0.20)	$5^{+0.2}_{0}$ (0.20)	5 (0.20)
	HC—RF103K to 203K	24h6 (0.94)	45 (1.77)	40 (1.57)	$8^{0}_{-0.036}$ (0.31)	25 (0.98)	5 (0.20)	$5^{+0.2}_{0}$ (0.16)	4 (0.16)
	HC—UF72K	22h6 (0.87)	55 (2.17)	50 (1.97)	$6^{0}_{-0.030}$ (0.24)	42 (1.65)	3 (0.12)	$3.5^{+0.2}_{0}$ (0.14)	3 (0.12)
	HC—UF152K	28h6 (1.10)	55 (2.17)	50 (1.97)	$8^{0}_{-0.036}$ (0.31)	45 (1.77)	5 (0.20)	$4^{+0.2}_{0}$ (0.16)	4 (0.16)
	HC—UF202K to 502K	35h6 (1.38)	65 (2.56)	60 (2.36)	$10^{0}_{-0.036}$ (0.39)	55 (2.17)	5 (0.20)	$5^{+0.2}_{0}$ (0.20)	5 (0.20)

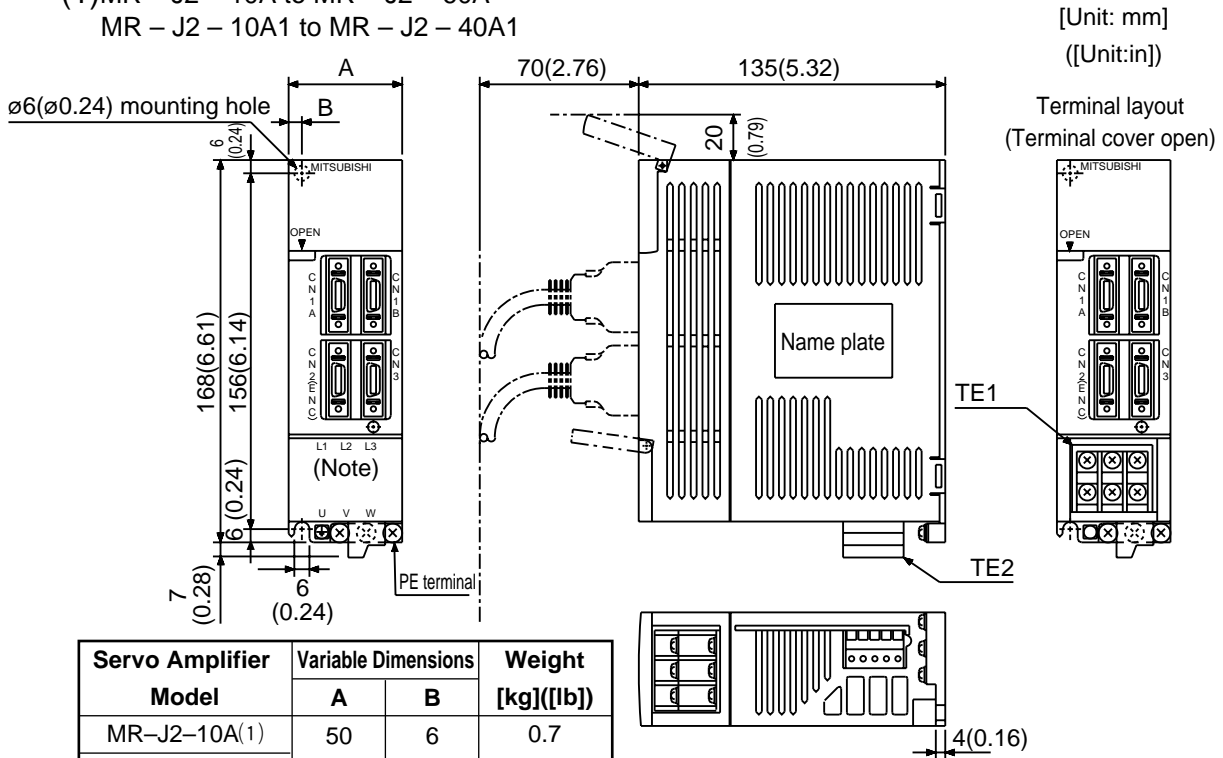
D cut		[Unit: mm] ([Unit: in])	
	<b>Servo Motor Model</b>	<b>Variable Dimensions</b>	
		<b>R</b>	<b>QK</b>
	HC—MF053D · 13D	25 (0.98)	20.5 (0.81)
	HA—FF053D · 13D	30 (1.178)	25.5 (1.00)
HC—UF13D	25 (0.98)	17.5 (0.69)	

# 10. SPECIFICATIONS

## 10-5 Outline dimension drawings

### 10-5-1 Servo amplifiers

(1) MR-J2-10A to MR-J2-60A  
MR-J2-10A1 to MR-J2-40A1



Note: This data applies to the three-phase 200V and single-phase 230V power supply models.

For the single-phase 100V power supply models, refer to Section 3-1-1.

#### TE1

• For three-phase 200V and single-phase 230V

L1	L2	L3
U	V	W

Terminal screw: M4 x 0.7

Tightening torque: 1.24 [N • m] (175.6 [oz • in])

• For single-phase 100V

L1	L2
U	W

Terminal screw: M4 x 0.7

Tightening torque: 1.24 [N • m] (175.6 [oz • in])

#### TE2

←Front

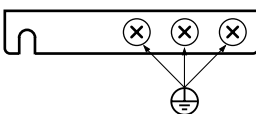
D	C	P	L21	L11
---	---	---	-----	-----

Tightening torque: 0.5 to 0.6 [N • m] (70.8 to 85.0 [oz • in])

FRONT MSTB2,5/5-ST-5,08

(Phoenix Contact make)

#### PE terminals

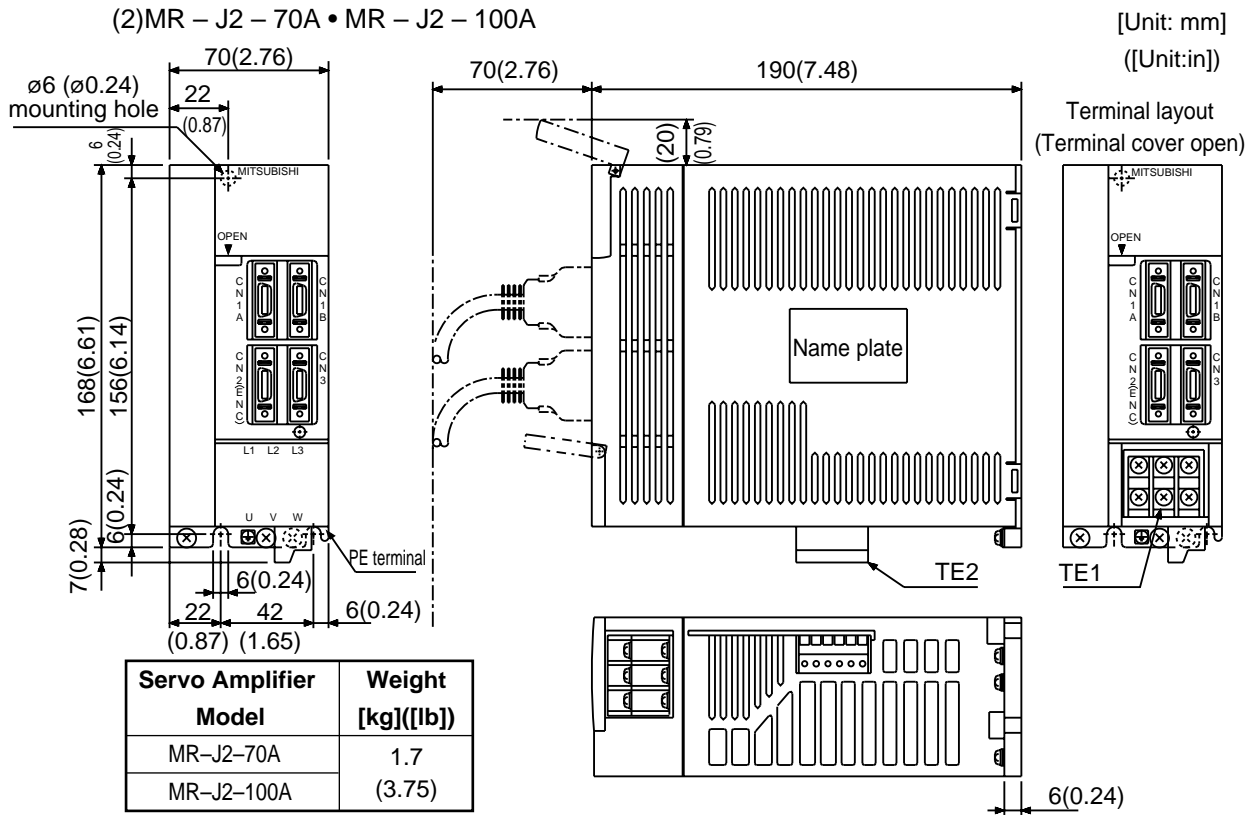


Terminal screw: M4 x 0.7

Tightening torque: 1.24 [N • m] (175.6 [oz • in])



# 10. SPECIFICATIONS



**TE1**



Terminal screw: M4 x 0.7

Tightening torque: 1.24 [N • m] (175.6 [oz • in])

**TE2**

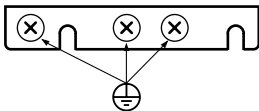
← Front



Tightening torque: 0.5 to 0.6 [N • m] (70.8 to 85.0 [oz • in])

FRONT MSTB2,5/6-ST-5,08  
(Phoenix Contact make)

**PE terminals**



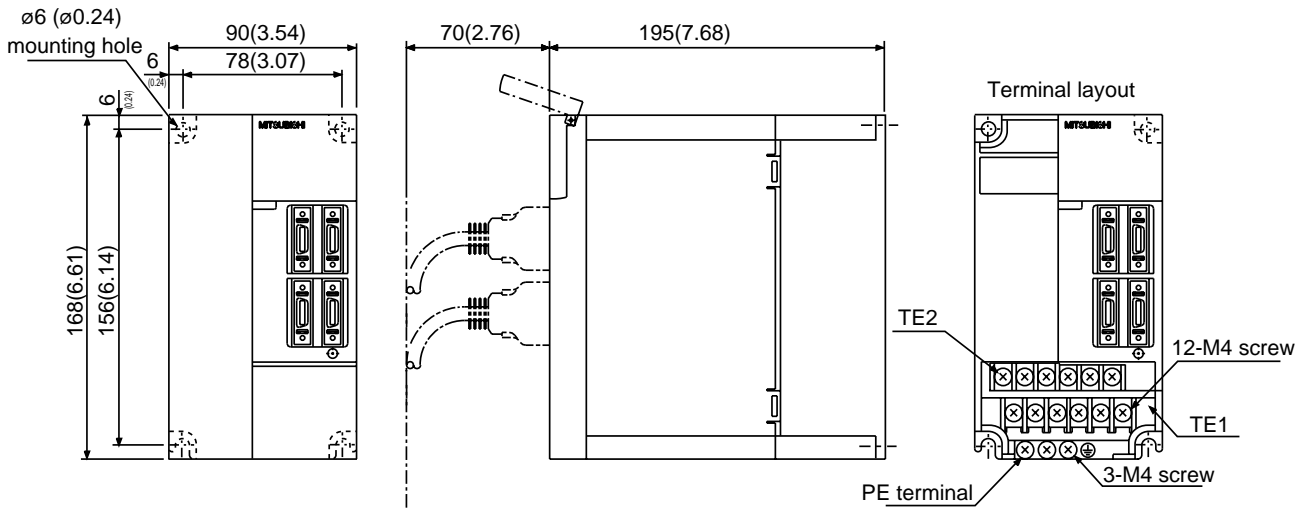
Terminal screw: M4 x 0.7

Tightening torque: 1.24 [N • m] (175.6 [oz • in])

# 10. SPECIFICATIONS

(3)MR - J2 - 200A • MR - J2 - 350A

[Unit : mm]  
([Unit: in])



Servo Amplifier Model	Weight [kg]([lb])
MR-J2-200A	2.0
MR-J2-350A	(4.41)

TE1

L1 L2 L3 U V W

Terminal screw: M4 x 0.7

Tightening torque: 1.24 [N • m] (175.6 [oz • in])

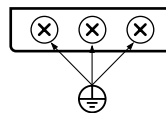
TE2

L11 L21 D P C N

Terminal screw: M4 x 0.7

Tightening torque: 1.24 [N • m] (175.6 [oz • in])

PE terminals



Terminal screw: M4 x 0.7

Tightening torque: 1.24 [N • m] (175.6 [oz • in])

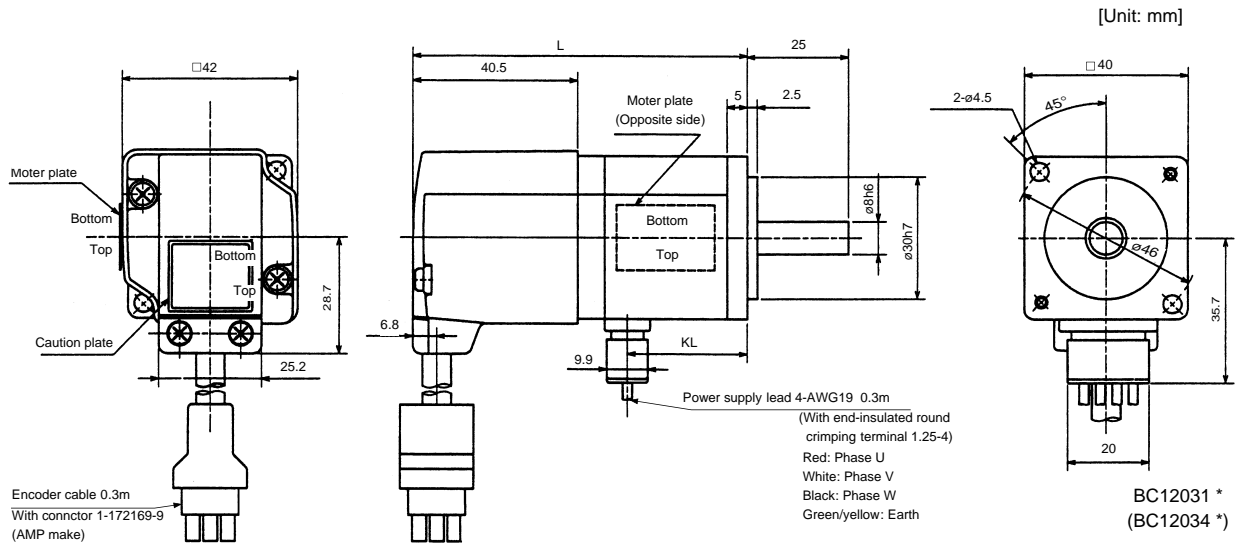
# 10. SPECIFICATIONS

## 10-5-2 Servo motors

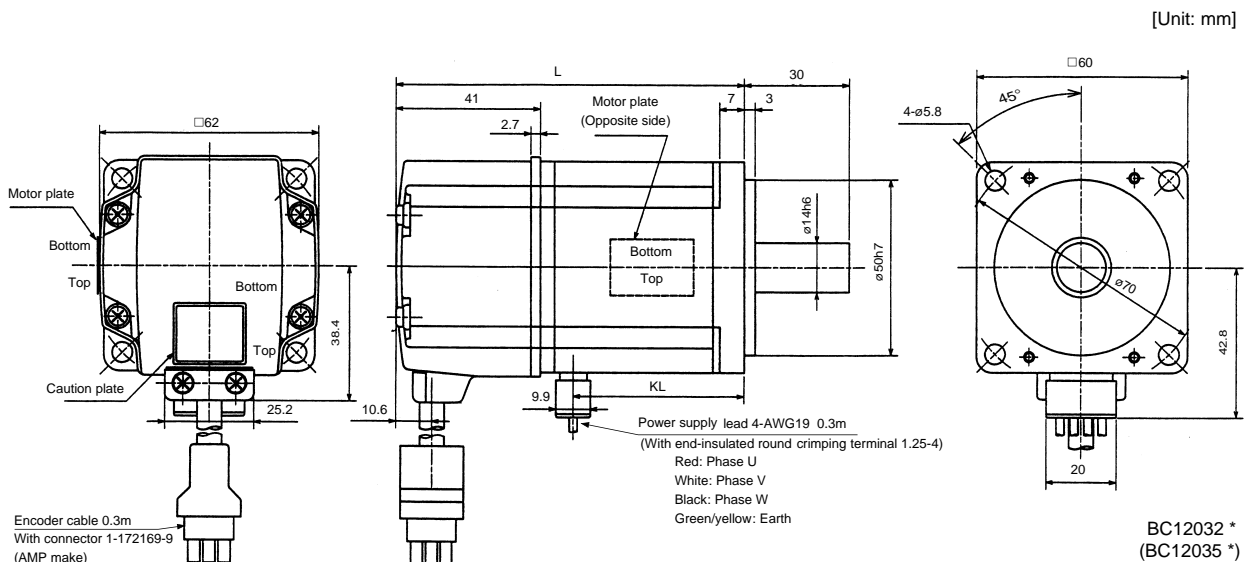
### (1) HC-MF series

#### 1) Standard (Without electromagnetic brake, without reduction gear)

Model	Output (W)	Variable Dimensions		Inertia Moment $J(\times 10^{-4} \text{kg}\cdot\text{m}^2)$	Weight (kg)
		L	KL		
HC-MF053	50	81.5	29.5	0.019	0.40
HC-MF13	100	96.5	44.5	0.03	0.53



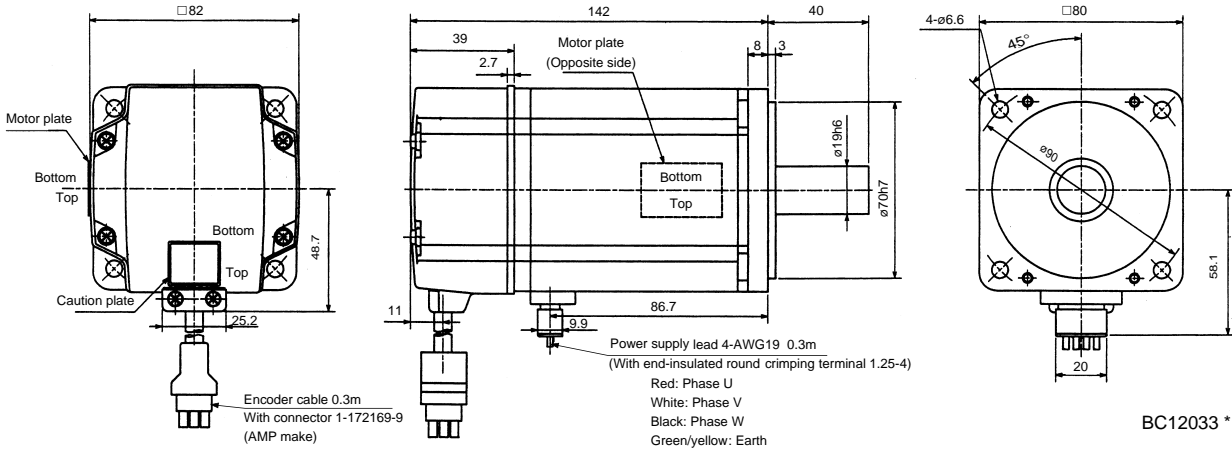
Model	Output (W)	Variable Dimensions		Inertia Moment $J(\times 10^{-4} \text{kg}\cdot\text{m}^2)$	Weight (kg)
		L	KL		
HC-MF23	200	99.5	49.1	0.088	0.99
HC-MF43	400	124.5	72.1	0.143	1.45



# 10. SPECIFICATIONS

Model	Output (W)	Inertia Moment $J(\times 10^{-4} \text{kg}\cdot\text{m}^2)$	Weight (kg)
HC-MF73	750	0.6	3

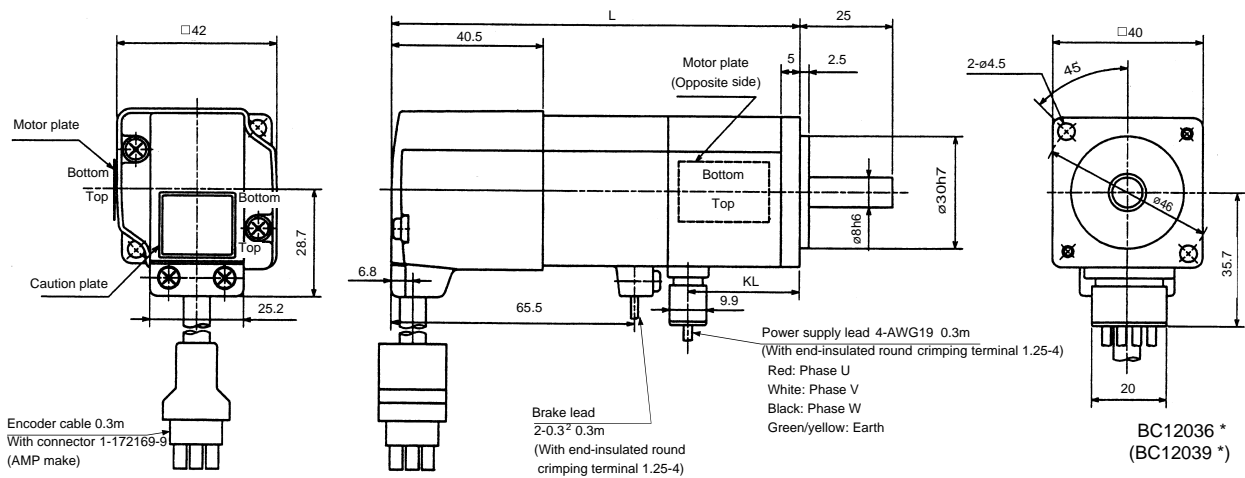
[Unit: mm]



## 2) With electromagnetic brake

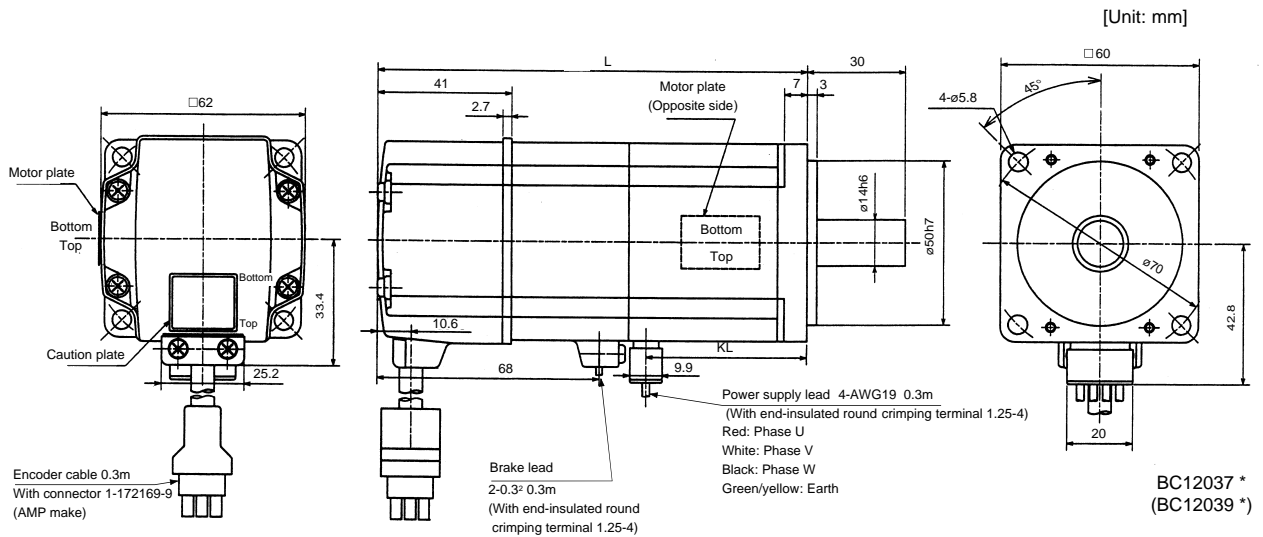
Model	Output (W)	Variable Dimensions		Barking Force (N•m)	Inertia Moment $J(\times 10^{-4} \text{kg}\cdot\text{m}^2)$	Weight (kg)
		L	KL			
HC-MF053B	50	109.5	29.5	0.32	0.022	0.75
HC-MF13B	100	124.5	44.5	0.32	0.032	0.89

[Unit: mm]

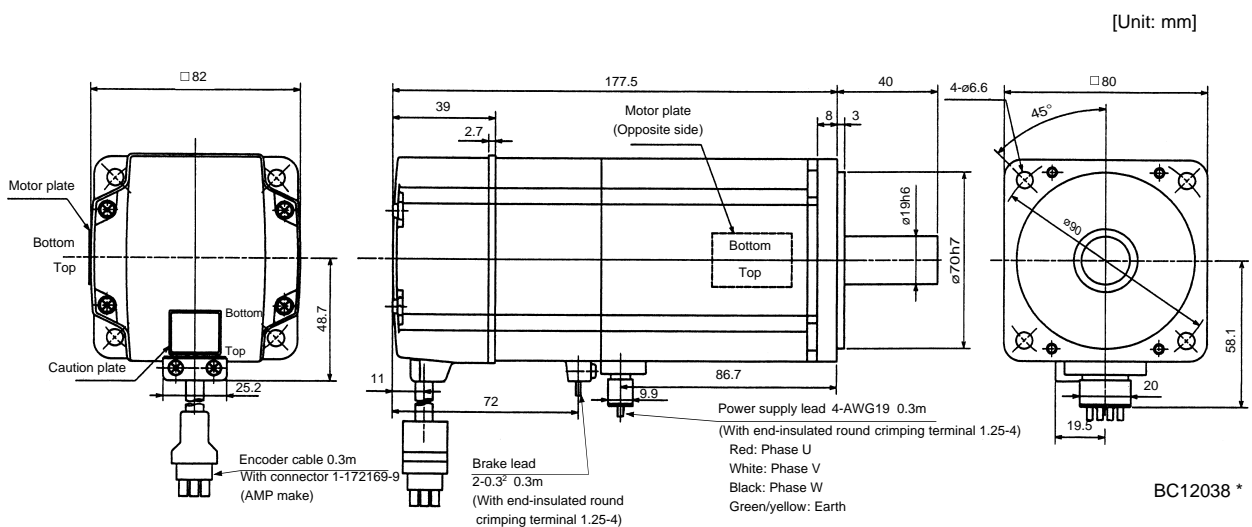


# 10. SPECIFICATIONS

Model	Output (W)	Variable Dimensions		Barking Force (N•m)	Inertia Moment J( $\times 10^{-4}$ kg•m <sup>2</sup> )	Weight (kg)
		L	KL			
HC-MF23B	200	131.5	49.1	1.3	0.136	1.6
HC-MF43B	400	156.5	72.1	1.3	0.191	2.1



Model	Output (W)	Barking Force (N•m)	Inertia Moment J( $\times 10^{-4}$ kg•m <sup>2</sup> )	Weight (kg)
HC-MF73B	750	2.4	0.725	4.0

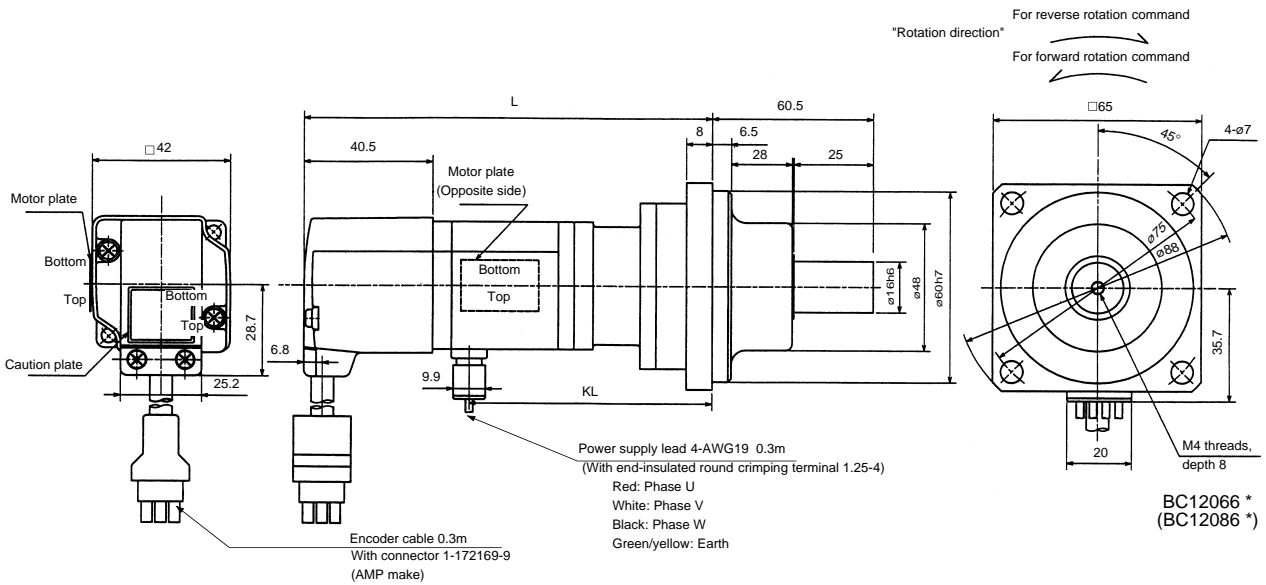


# 10. SPECIFICATIONS

- 3) With reduction gear for general industrial machine
  - a) Without electromagnetic brake

Model	Output (W)	Variable Dimensions		Reduction Gear Model	Reduction Ratio (Actual Reduction Ratio)	Inertia Moment $J(\times 10^{-4} \text{kg}\cdot\text{m}^2)$	Backlash	Weight (kg)
		L	KL					
HC-MF053G1	50	126	74	K6505	1/5(9/44)	0.055	60min. max.	1.4
HC-MF053G1	50	144	92	K6512	1/12(49/576)	0.077	60min. max.	1.8
HC-MF053G1	50	144	92	K6520	1/20(25/484)	0.059	60min. max.	1.8

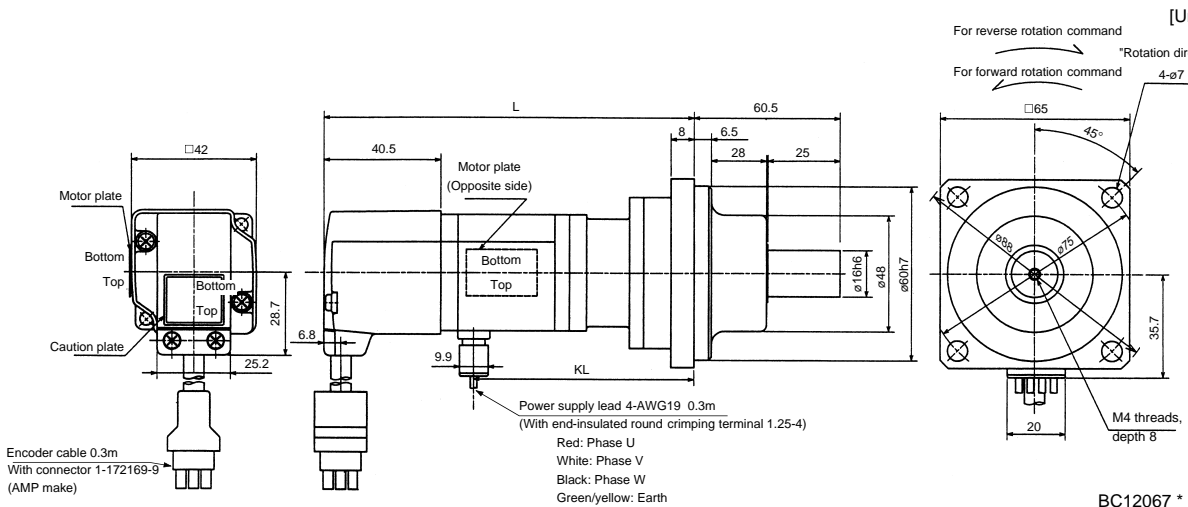
[Unit: mm]



BC12066 \*  
(BC12086 \*)

Model	Output (W)	Variable Dimensions		Reduction Gear Model	Reduction Ratio (Actual Reduction Ratio)	Inertia Moment $J(\times 10^{-4} \text{kg}\cdot\text{m}^2)$	Backlash	Weight (kg)
		L	KL					
HC-MF13G1	100	141	89	K6505	1/5(9/44)	0.067	60min. max.	1.5
HC-MF13G1	100	159	107	K6512	1/12(49/576)	0.089	60min. max.	1.9
HC-MF13G1	100	159	107	K6520	1/20(25/484)	0.071	60min. max.	1.9

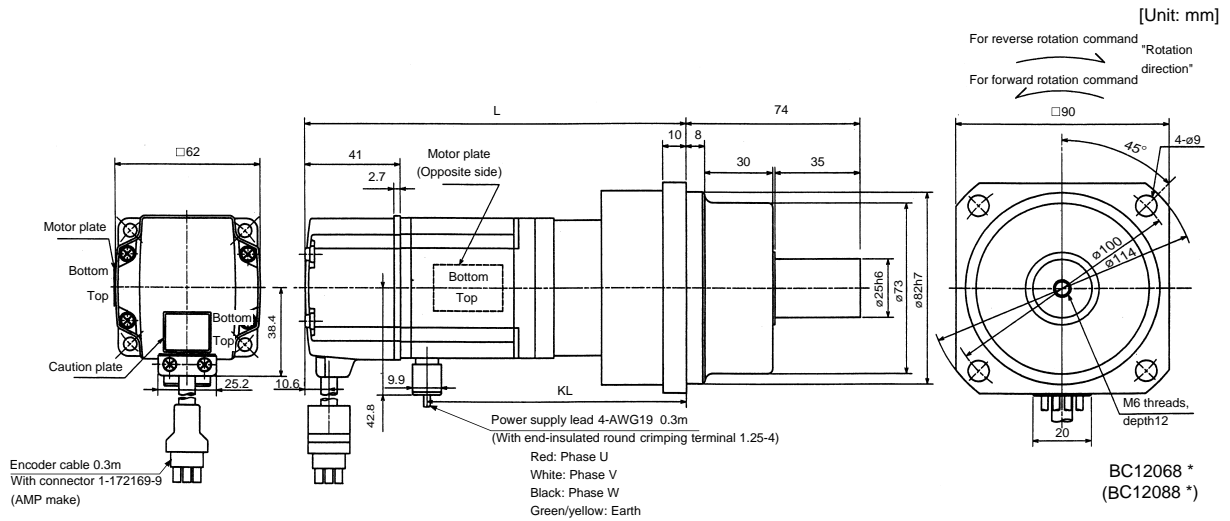
[Unit: mm]



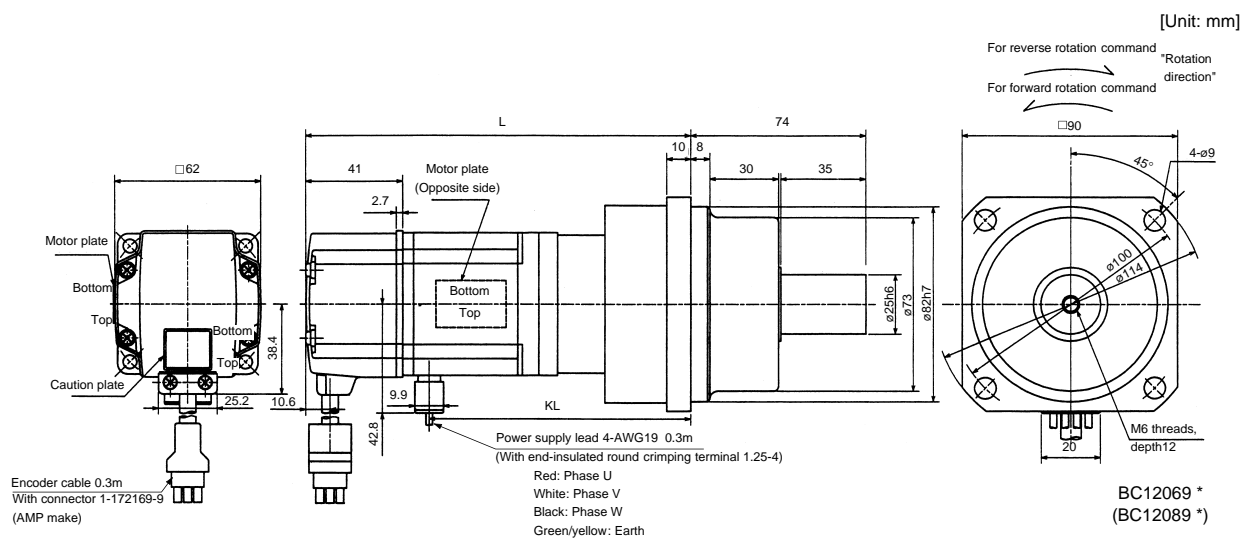
BC12067 \*  
(BC12087 \*)

# 10. SPECIFICATIONS

Model	Output (W)	Variable Dimensions		Reduction Gear Model	Reduction Ratio (Actual Reduction Ratio)	Inertia Moment $J(\times 10^{-4} \text{kg}\cdot\text{m}^2)$	Weight (kg)
		L	KL				
HC-MF23G1	200	153	102.6	K9005	1/5(19/96)	0.249	3.3
HC-MF23G1	200	173	122.6	K9012	1/12(25/288)	0.293	3.9
HC-MF23G1	200	173	122.6	K9020	1/20(253/5000)	0.266	3.9



Model	Output (W)	Variable Dimensions		Reduction Gear Model	Reduction Ratio (Actual Reduction Ratio)	Inertia Moment $J(\times 10^{-4} \text{kg}\cdot\text{m}^2)$	Weight (kg)
		L	KL				
HC-MF43G1	400	178	125.6	K9005	1/5(19/96)	0.296	3.8
HC-MF43G1	400	198	145.6	K9012	1/12(25/288)	0.339	4.4

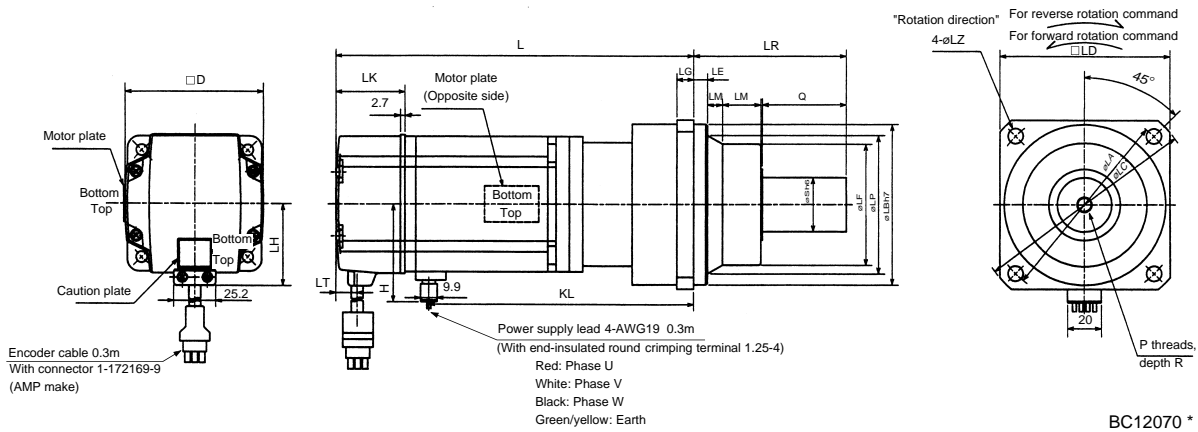


# 10. SPECIFICATIONS

Model	Output (W)	Reduction Gear Model	Reduction Ratio		Inertia Moment J( $\times 10^{-4}$ kg·m <sup>2</sup> )	Backlash	Weight (kg)
			Normal Reduction ratio	Actual Reduction ratio			
HC-MF43G1	400	K10020	1/20	253/5000	0.653	60min. max.	5.5
HC-MF73G1	750	K10005	1/5	1/5	1.02	60min. max.	6.2
HC-MF73G1	750	K10012	1/12	525/6048	1.686	60min. max.	7.3
HC-MF73G1	750	K12020	1/20	625/12544	1.75	60min. max.	10.1

Model	Output (W)	Variable Dimensions																			(Reduction Ratio)				
		D	L	H	LK	LT	H	LA	LB	LC	LD	LE	LF	LG	LM	LN	LP	L	LR	KL		LZ	Q	S	P
HC-MF43G1	400	62	38.4	41	10.6	42.8	115	95	132	100	10	73	10	13	16	86	201.5	90	149.1	9	50	32	M8	16	1/20
HC-MF73G1	750	82	48.7	39	11	58.1	115	95	132	100	10	73	10	13	16	86	207	90	151.7	9	50	32	M8	16	1/5
HC-MF73G1	750	82	48.7	39	11	58.1	115	95	132	100	10	73	10	13	16	86	229	90	173.7	9	50	32	M8	16	1/12
HC-MF73G1	750	82	48.7	39	11	58.1	140	115	162	120	12	90	15	13	20	104	242	106	186.7	14	60	40	M10	20	1/20

[Unit: mm]

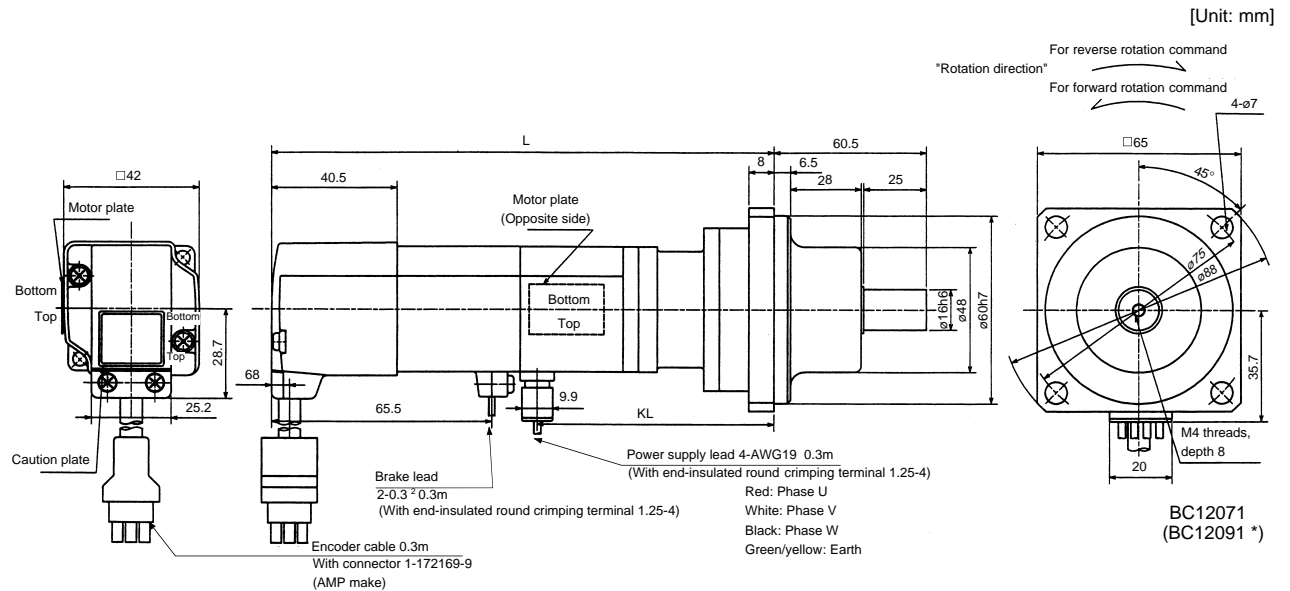




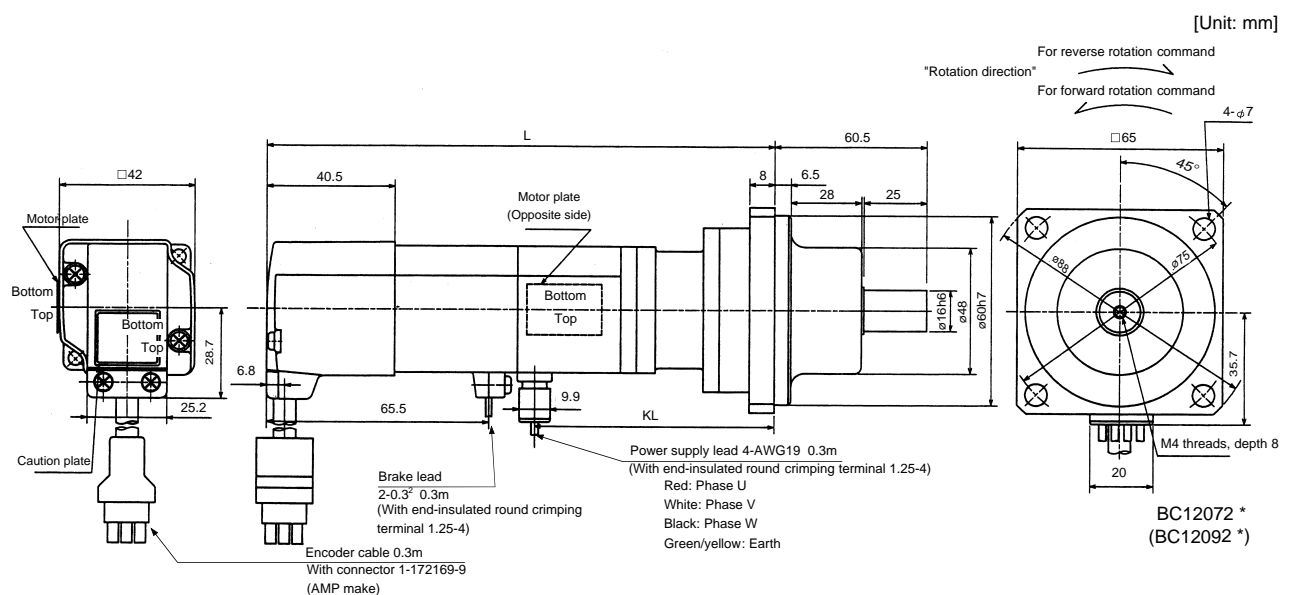
# 10. SPECIFICATIONS

b) With electromagnetic brake

Model	Output (W)	Variable Dimensions		Braking Force (N•m)	Reduction Gear Model	Reduction Ratio	Inertia Moment J( $\times 10^{-4}$ kg•m <sup>2</sup> )	Backlash	Weight (kg)
		L	KL						
HC-MF053BG1	50	154	74	0.32	K6505	1/5(9/44)	0.058	60min. max.	1.8
HC-MF053BG1	50	172	92	0.32	K6512	1/12(49/576)	0.080	60min. max.	2.2
HC-MF053BG1	50	172	92	0.32	K6520	1/20(25/484)	0.062	60min. max.	2.2

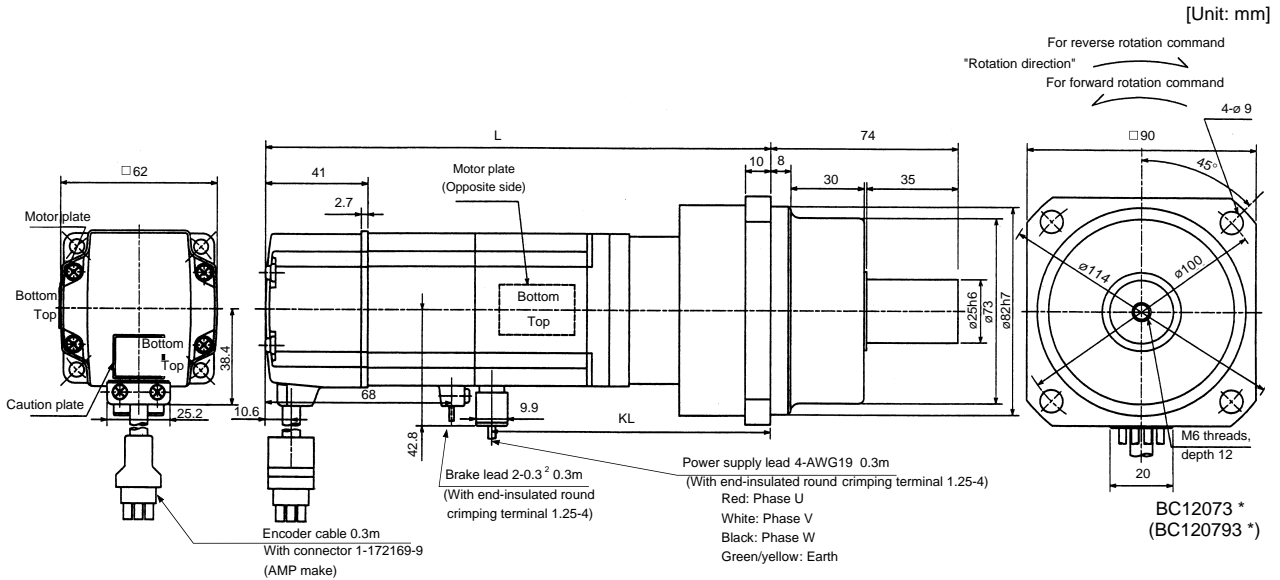


Model	Output (W)	Variable Dimensions		Braking Force (N•m)	Reduction Gear Model	Reduction Ratio	Inertia Moment J( $\times 10^{-4}$ kg•m <sup>2</sup> )	Backlash	Weight (kg)
		L	KL						
HC-MF13BG1	100	169	89	0.32	K6505	1/5(9/44)	0.069	60min. max.	1.9
HC-MF13BG1	100	187	107	0.32	K6512	1/12(49/576)	0.091	60min. max.	2.3
HC-MF13BG1	100	187	107	0.32	K6520	1/20(25/484)	0.073	60min. max.	2.3

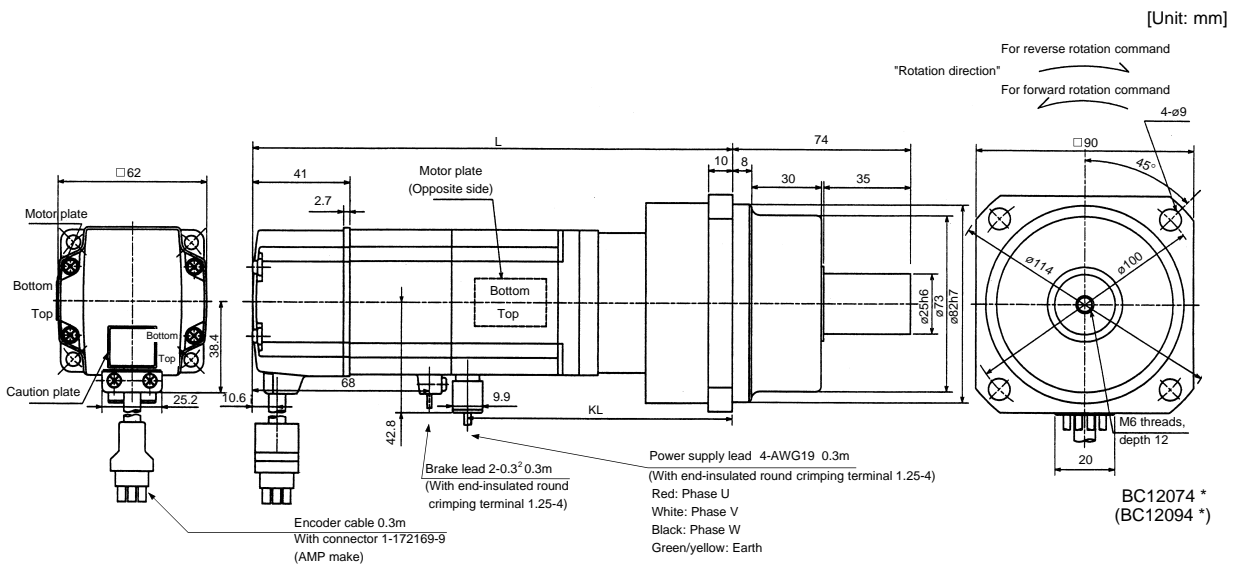


# 10. SPECIFICATIONS

Model	Output (W)	Variable Dimensions		Reduction Gear Model	Reduction Ratio (Actual Reduction Ratio)	Inertia Moment $J(\times 10^{-4} \text{kg}\cdot\text{m}^2)$	Weight (kg)
		L	KL				
HC-MF23BG1	200	185	102.6	K9005	1/5(19/96)	0.289	3.9
HC-MF23BG1	200	205	122.6	K9012	1/12(25/288)	0.333	4.5
HC-MF23BG1	200	205	122.6	K9020	1/20(253/5000)	0.306	4.5



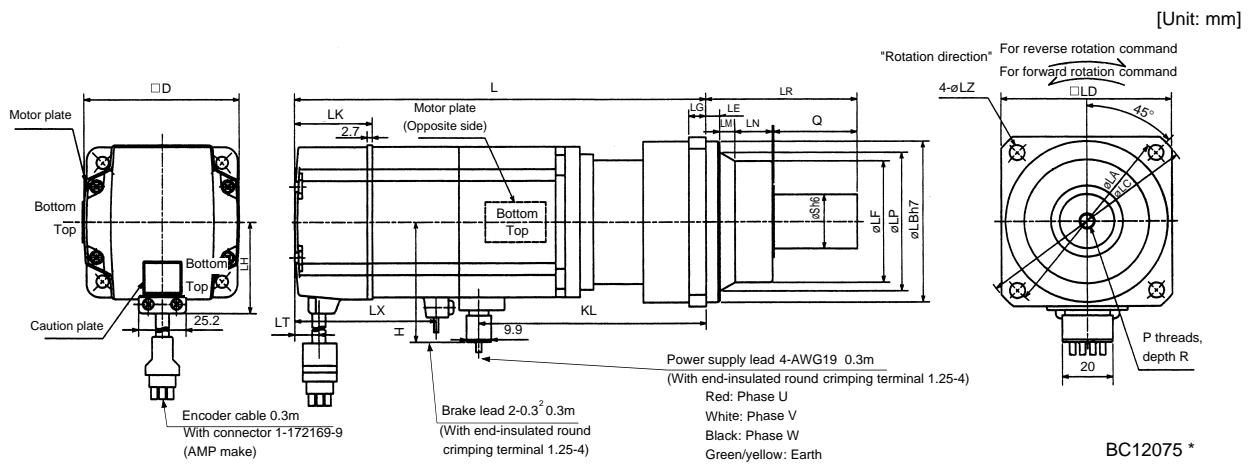
Model	Output (W)	Variable Dimensions		Reduction Gear Model	Reduction Ratio (Actual Reduction Ratio)	Inertia Moment $J(\times 10^{-4} \text{kg}\cdot\text{m}^2)$	Weight (kg)
		L	KL				
HC-MF43BG1	400	210	125.6	K9005	1/5(19/96)	0.344	4.4
HC-MF43BG1	400	230	145.6	K9012	1/12(25/288)	0.388	5.0



# 10. SPECIFICATIONS

Model	Output (W)	Brake Force (N•m)	Reduction Gear Model	Reduction Ratio		Inertia Moment J( $\times 10^{-4}$ kgm <sup>2</sup> )	Backlash	Weight (kg)
				Normal Reduction ratio	Actual Reduction ratio			
HC-MF43BG1	400	1.3	K10020	1/20	253/5000	0.700	60min. max.	6.1
HC-MF73BG1	750	2.4	K10005	1/5	1/5	1.145	60min. max.	7.2
HC-MF73BG1	750	2.4	K10012	1/12	525/6048	1.811	60min. max.	8.3
HC-MF73BG1	750	2.4	K12020	1/20	625/12544	1.875	60min. max.	11.1

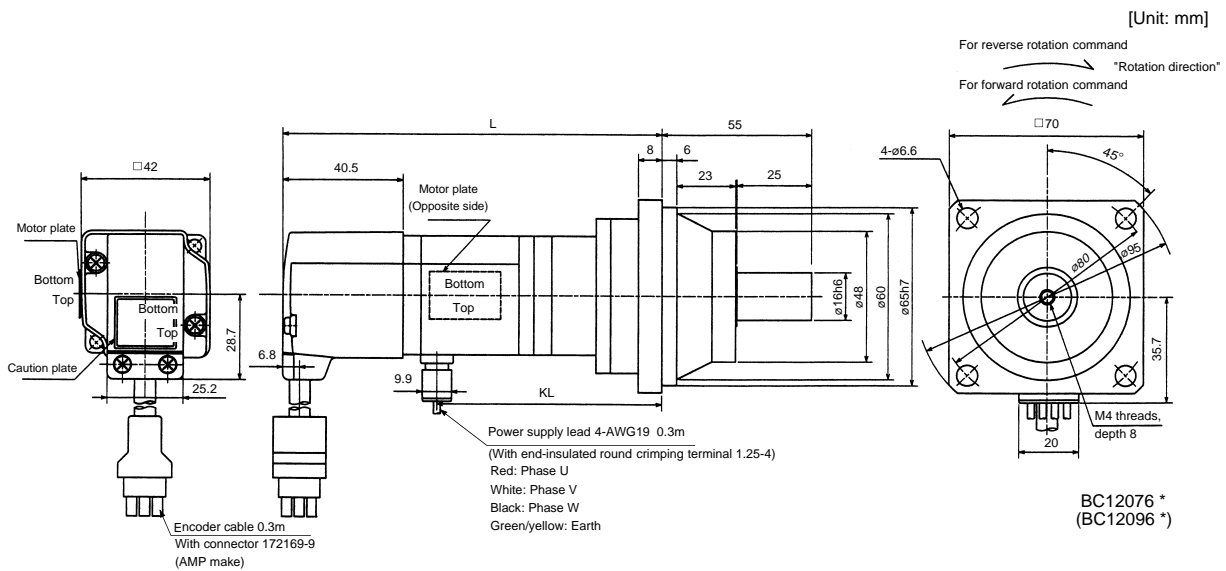
Model	Output (W)	Variable Dimensions																(Reduction Ratio)								
		D	LH	LK	LT	LX	H	LA	LB	LC	LD	LE	LF	LG	LM	LN	LP		L	LR	KL	LZ	Q	S	P	R
HC-MF43BG1	400	62	38.4	41	10.6	68	42.8	115	95	132	100	10	73	10	13	16	86	232.5	90	149.1	9	50	32	M8	16	1/20
HC-MF73BG1	750	82	48.7	39	11	72	58.1	115	95	132	100	10	73	10	13	16	86	242.5	90	151.7	9	50	32	M8	16	1/5
HC-MF73BG1	750	82	48.7	39	11	72	58.1	115	95	132	100	10	73	10	13	16	86	264.5	90	173.7	9	50	32	M8	16	1/12
HC-MF73BG1	750	82	48.7	39	11	72	58.1	140	115	162	120	12	90	15	13	20	104	277.5	106	186.7	14	60	40	M10	20	1/20



# 10. SPECIFICATIONS

- 4) With reduction gear for precision application
  - a) Without electromagnetic brake

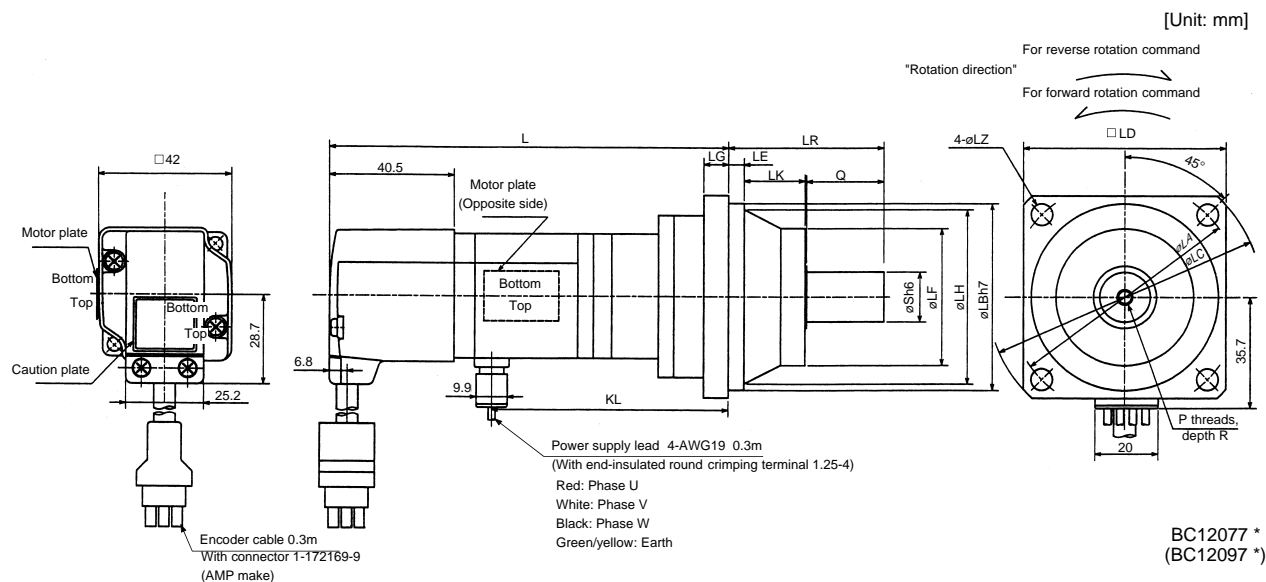
Model	Output (W)	Variable Dimensions		Reduction Gear Model	Reduction Ratio	Inertia Moment J( $\times 10^{-4}$ kg $\cdot$ m $^2$ )	Backlash	Weight (kg)
		L	KL					
HC-MF053G2	50	130	78	BK1-05B-A5MEKA	1/5	0.067	3 min. max.	1.4
HC-MF053G2	50	146	94	BK1-09B-A5MEKA	1/9	0.060	3 min. max.	1.7
HC-MF053G2	50	146	94	BK1-20B-A5MEKA	1/20	0.069	3 min. max.	1.8
HC-MF053G2	50	146	94	BK1-29B-A5MEKA	1/29	0.057	3 min. max.	1.8



# 10. SPECIFICATIONS

Model	Output (W)	Reduction Gear Model	Reduction Ratio	Inertia Moment J( $\times 10^{-4} \text{kg}\cdot\text{m}^2$ )	Backlash	Weight (kg)
HC-MF13BG2	100	BK1-05B-01MEKA	1/5	0.078	3 min. max.	1.5
HC-MF13BG2	100	BK1-09B-01MEKA	1/9	0.072	3 min. max.	1.8
HC-MF13BG2	100	BK1-20B-01MEKA	1/20	0.122	3 min. max.	3.0
HC-MF13BG2	100	BK1-29B-01MEKA	1/29	0.096	3 min. max.	3.0

Model	Output (W)	Variable Dimensions																	(Reduction Ratio)
		LA	LB	LC	LD	LE	LF	LG	LH	LK	L	LR	KL	LZ	Q	S	P	R	
HC-MF13BG2	100	80	65	95	70	6	48	8	60	23	145	55	93	6.6	25	16	M4	8	1/5
HC-MF13BG2	100	80	65	95	70	6	48	8	60	23	161	55	109	6.6	25	16	M4	8	1/9
HC-MF13BG2	100	100	80	115	85	6	65	10	74	33	167	75	115	6.6	35	20	M5	10	1/20
HC-MF13BG2	100	100	80	115	85	6	65	10	74	33	167	75	115	6.6	35	20	M5	10	1/29



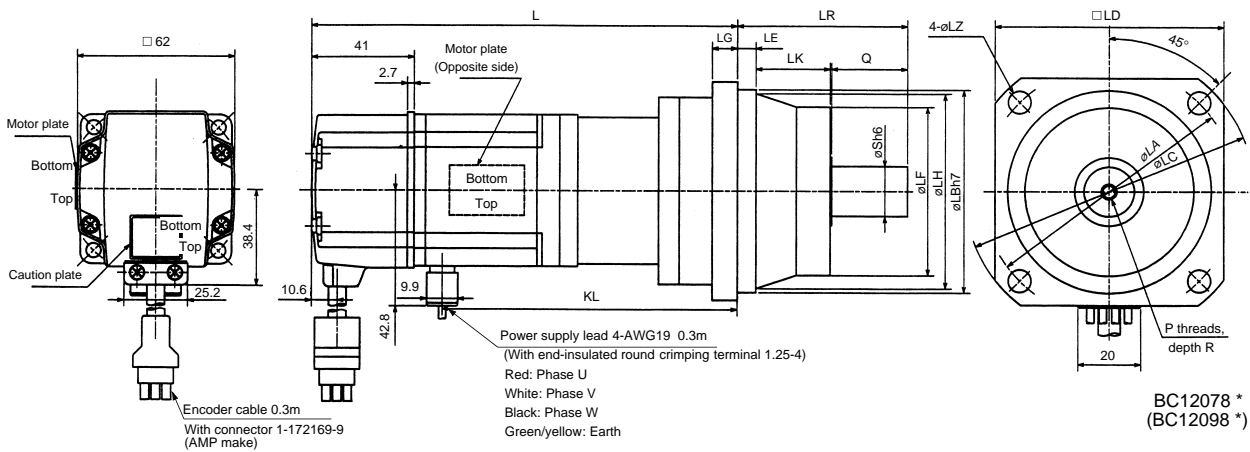
# 10. SPECIFICATIONS

Model	Output (W)	Reduction Gear Model	Reduction Ratio	Inertia Moment $J(\times 10^{-4} \text{kg}\cdot\text{m}^2)$	Weight (kg)
HC-MF23BG2	200	BK1-05B-02MEKA	1/5	0.191	2.1
HC-MF23BG2	200	BK2-09B-02MEKA	1/9	0.208	3.5
HC-MF23BG2	200	BK3-20B-02MEKA	1/20	0.357	5.0
HC-MF23BG2	200	BK3-29B-02MEKA	1/29	0.276	5.0

Model	Output (W)	Variable Dimensions																	(Reduction Ratio)
		LA	LB	LC	LD	LE	LF	LG	LH	LK	L	LR	KL	LZ	Q	S	P	R	
HC-MF23BG2	200	80	65	95	70	6	48	8	60	23	157	55	106.6	6.6	25	16	M4	8	1/5
HC-MF23BG2	200	100	80	115	85	6	65	10	74	33	175	75	124.6	6.6	35	20	M5	10	1/9
HC-MF23BG2	200	115	95	135	100	8	75	10	85	35	180	85	129.6	9	40	25	M6	12	1/20
HC-MF23BG2	200	115	95	135	100	8	75	10	85	35	180	85	129.6	9	40	25	M6	12	1/29

[Unit: mm]

For reverse rotation command  
 "Rotation direction" For forward rotation command

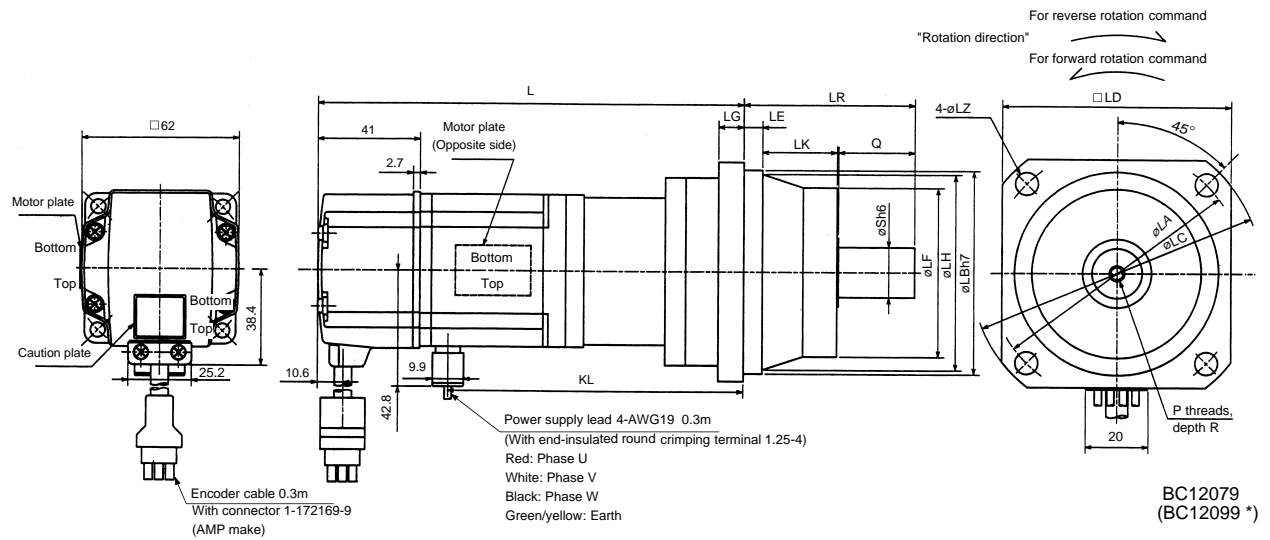


# 10. SPECIFICATIONS

Model	Output (W)	Reduction Gear Model	Reduction Ratio	Inertia Moment $J(\times 10^{-4} \text{kg}\cdot\text{m}^2)$	Weight (kg)
HC-MF43BG2	400	BK2-05B-04MEKA	1/5	0.295	3.7
HC-MF43BG2	400	BK3-09B-04MEKA	1/9	0.323	5.3
HC-MF43BG2	400	BK4-20B-04MEKA	1/20	0.426	7.5
HC-MF43BG2	400	BK4-29B-04MEKA	1/29	0.338	7.5

Model	Output (W)	Variable Dimensions																	(Reduction Ratio)
		LA	LB	LC	LD	LE	LF	LG	LH	LK	L	LR	KL	LZ	Q	S	P	R	
HC-MF43BG2	400	100	80	115	85	6	65	10	74	33	184	75	131.6	6.6	35	20	M5	10	1/5
HC-MF43BG2	400	115	95	135	100	8	75	10	85	35	205	85	152.6	9	40	25	M6	12	1/9
HC-MF43BG2	400	135	110	155	115	8	90	12	100	40	211	100	158.6	11	50	32	M8	16	1/20
HC-MF43BG2	400	135	110	155	115	8	90	12	100	40	211	100	158.6	11	50	32	M8	16	1/29

[Unit: mm]

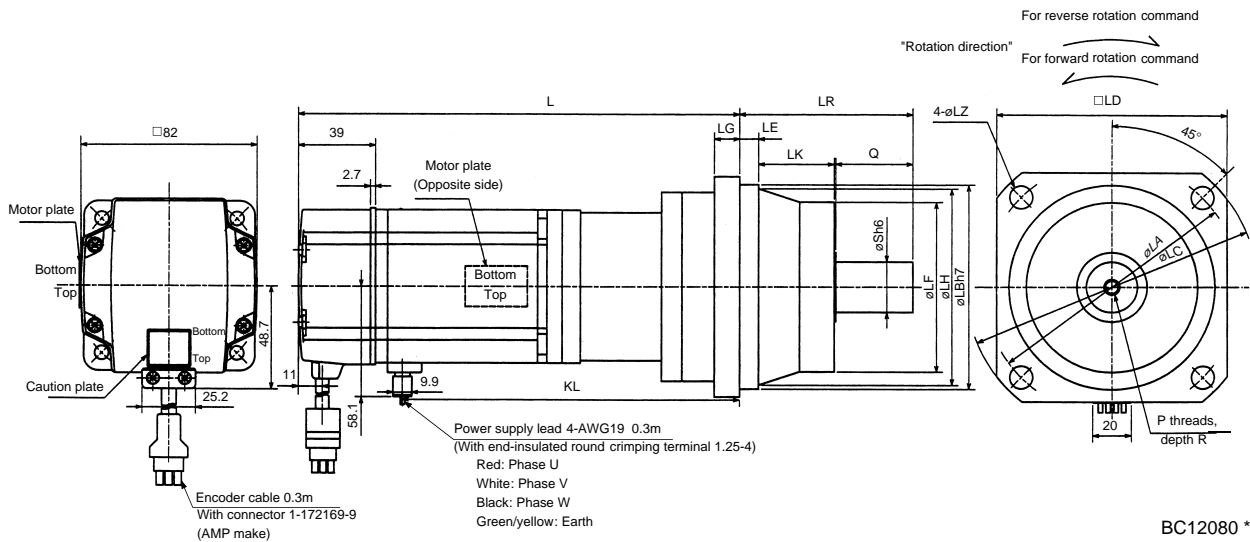


# 10. SPECIFICATIONS

Model	Output (W)	Reduction Gear Model	Reduction Ratio	Inertia Moment $J(\times 10^{-4} \text{kg}\cdot\text{m}^2)$	Weight (kg)
HC-MF73G2	750	BK3-05B-08MEKA	1/5	0.973	6.3
HC-MF73G2	750	BK4-09B-08MEKA	1/9	0.980	8.6
HC-MF73G2	750	BK5-20B-08MEKA	1/20	1.016	12.0
HC-MF73G2	750	BK5-29B-08MEKA	1/29	0.910	12.0

Model	Output (W)	Variable Dimensions																	(Reduction Ratio)
		LA	LB	LC	LD	LE	LF	LG	LH	LK	L	LR	KL	LZ	Q	S	P	R	
HC-MF73G2	750	115	95	135	100	8	75	10	85	35	212	85	156.7	9	40	25	M6	12	1/5
HC-MF73G2	750	135	110	155	115	8	90	12	100	40	248	100	192.7	11	50	32	M8	16	1/9
HC-MF73G2	750	150	125	175	130	10	105	15	115	43	248	115	192.7	14	60	40	M10	20	1/20
HC-MF73G2	750	150	125	175	130	10	105	15	115	43	248	115	192.7	14	60	40	M10	20	1/29

[Unit: mm]

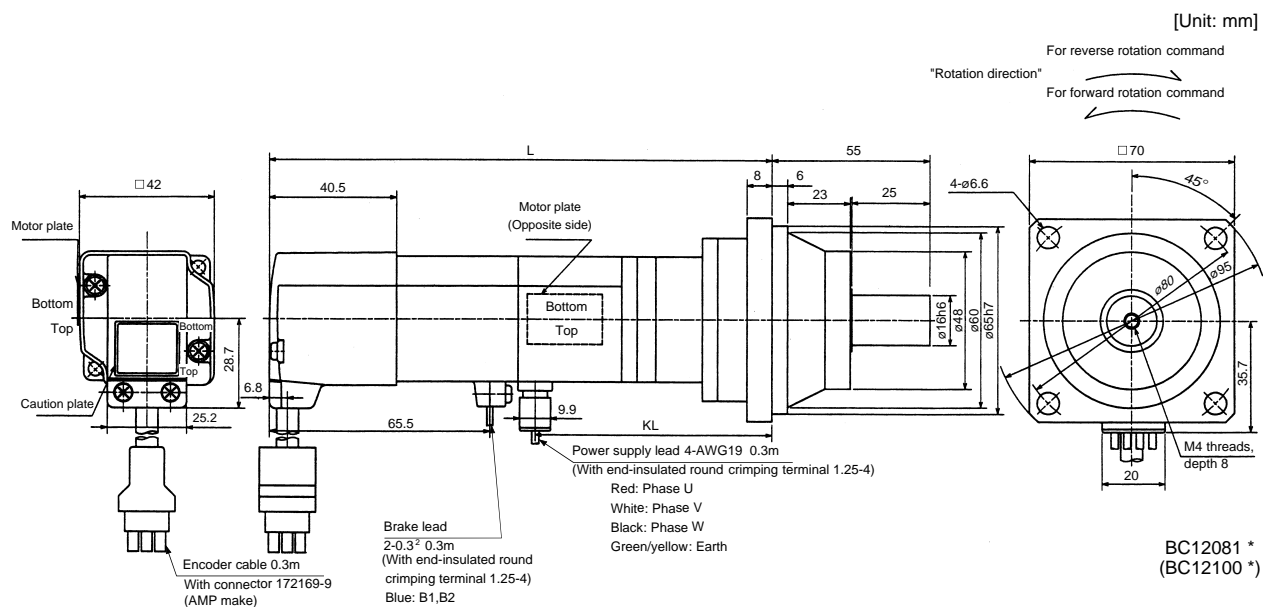




# 10. SPECIFICATIONS

## b) With electromagnetic brake

Model	Output (W)	Variable Dimensions		Braking Force (N•m)	Reduction Gear Model	Reduction Ratio	Inertia Moment J( $\times 10^{-4} \text{kg}\cdot\text{m}^2$ )	Backlash	Weight (kg)
		L	KL						
HC-MF053BG2	50	158	78	0.32	BK1-05B-A5MEKA	1/5	0.070	3 min. max.	1.8
HC-MF053BG2	50	174	94	0.32	BK1-09B-A5MEKA	1/9	0.063	3 min. max.	2.1
HC-MF053BG2	50	174	94	0.32	BK1-20B-A5MEKA	1/20	0.072	3 min. max.	2.2
HC-MF053BG2	50	174	94	0.32	BK1-29B-A5MEKA	1/20	0.060	3 min. max.	2.2

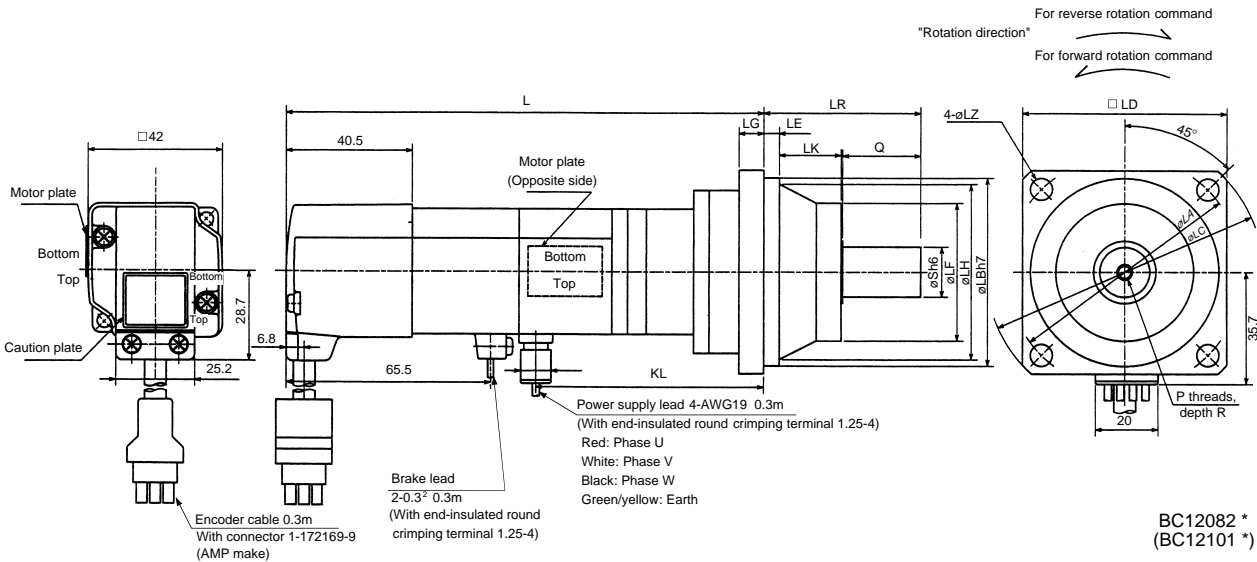


# 10. SPECIFICATIONS

Model	Output (W)	Braking Force (N·m)	Reduction Gear Model	Reduction Ratio	Inertia Moment $J(\times 10^{-4} \text{kg}\cdot\text{m}^2)$	Backlash	Weight (kg)
HC-MF13BG2	100	0.32	BK1-05B-01MEKA	1/5	0.080	3 min. max.	1.9
HC-MF13BG2	100	0.32	BK1-09B-01MEKA	1/9	0.074	3 min. max.	2.2
HC-MF13BG2	100	0.32	BK2-20B-01MEKA	1/20	0.124	3 min. max.	3.4
HC-MF13BG2	100	0.32	BK2-29B-01MEKA	1/29	0.098	3 min. max.	3.4

Model	Output (W)	Variable Dimensions																	(Reduction Ratio)
		LA	LB	LC	LD	LE	LF	LG	LH	LK	L	LR	KL	LZ	Q	S	P	R	
HC-MF13BG2	100	80	65	95	70	6	48	8	60	23	173	55	93	6.6	25	16	M4	8	1/5
HC-MF13BG2	100	80	65	95	70	6	48	8	60	23	189	55	109	6.6	25	16	M4	8	1/9
HC-MF13BG2	100	100	80	115	85	6	65	10	74	33	195	75	115	6.6	35	20	M5	10	1/20
HC-MF13BG2	100	100	80	115	85	6	65	10	74	33	195	75	115	6.6	35	20	M5	10	1/29

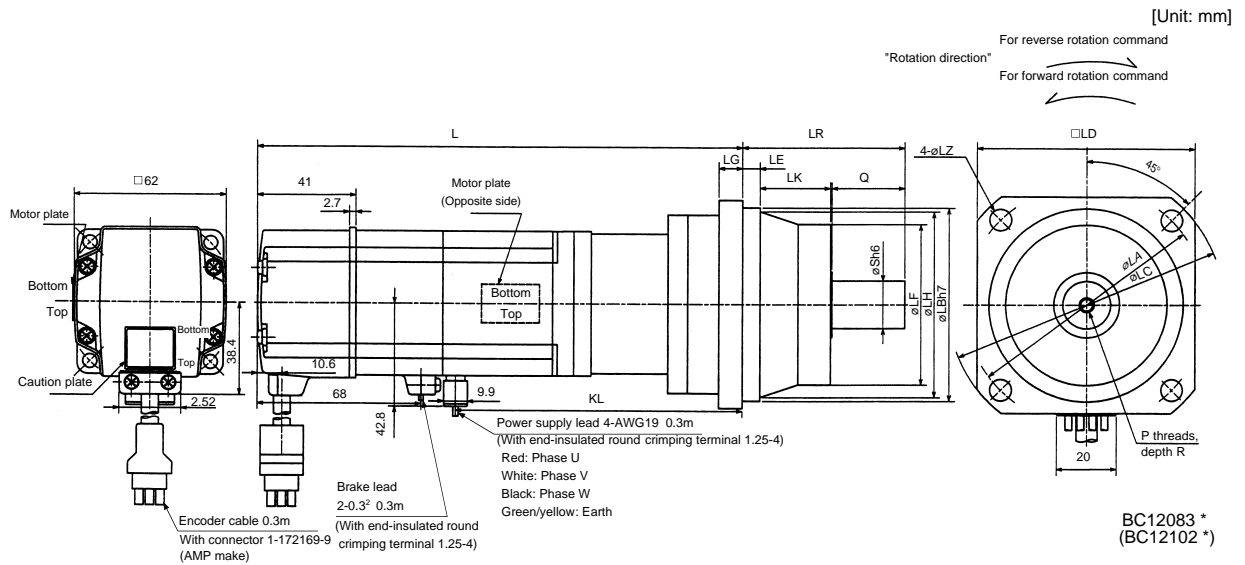
[Unit: mm]



# 10. SPECIFICATIONS

Model	Output (W)	Braking Force (N•m)	Reduction Gear Model	Reduction Ratio	Inertia Moment J( $\times 10^{-4} \text{kg}\cdot\text{m}^2$ )	Weight (kg)
HC-MF23BG2	200	1.3	BK1-05B-02MEKA	1/5	0.239	2.7
HC-MF23BG2	200	1.3	BK2-09B-02MEKA	1/9	0.256	4.1
HC-MF23BG2	200	1.3	BK3-20B-02MEKA	1/20	0.405	5.6
HC-MF23BG2	200	1.3	BK3-29B-02MEKA	1/29	0.324	5.6

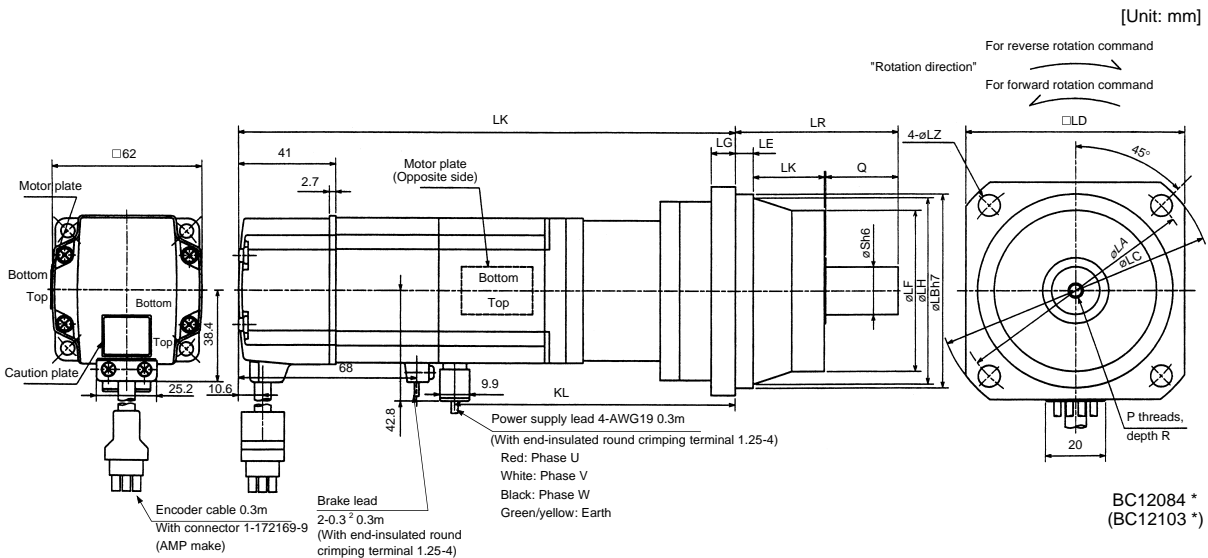
Model	Output (W)	Variable Dimensions																	(Reduction Ratio)
		LA	LB	LC	LD	LE	LF	LG	LH	LK	L	LR	KL	LZ	Q	S	P	R	
HC-MF23BG2	200	80	65	95	70	6	48	8	60	23	189	55	106.6	6.6	25	16	M4	8	1/5
HC-MF23BG2	200	100	80	115	85	6	65	10	74	33	207	75	124.6	6.6	35	20	M5	10	1/9
HC-MF23BG2	200	115	95	135	100	8	75	10	85	35	212	85	129.6	9	40	25	M6	12	1/20
HC-MF23BG2	200	115	95	135	100	8	75	10	85	35	212	85	129.6	9	40	25	M6	12	1/29



# 10. SPECIFICATIONS

Model	Output (W)	Braking Force (N•m)	Reduction Gear Model	Reduction Ratio	Inertia Moment $J(\times 10^{-4} \text{kg}\cdot\text{m}^2)$	Weight (kg)
HC-MF43BG2	400	1.3	BK2-05B-04MEKA	1/5	0.344	4.3
HC-MF43BG2	400	1.3	BK3-09B-04MEKA	1/9	0.372	5.9
HC-MF43BG2	400	1.3	BK4-20B-04MEKA	1/20	0.475	8.1
HC-MF43BG2	400	1.3	BK4-29B-04MEKA	1/29	0.386	8.1

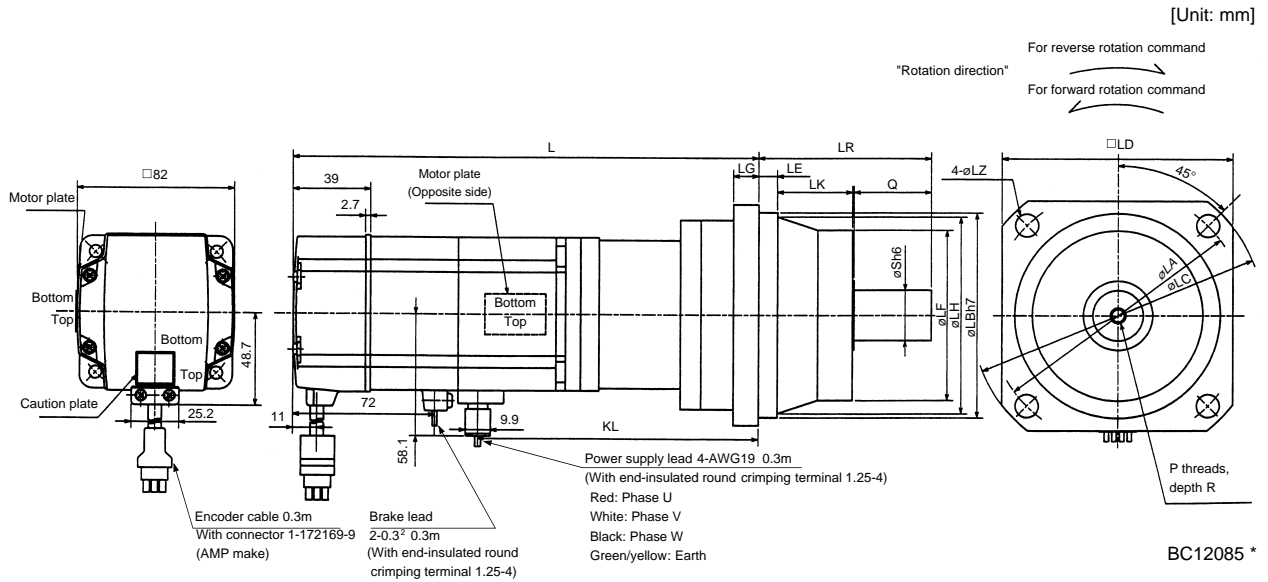
Model	Output (W)	Variable Dimensions																	(Reduction Ratio)
		LA	LB	LC	LD	LE	LF	LG	LH	LK	L	LR	KL	LZ	Q	S	P	R	
HC-MF43BG2	400	100	80	115	85	6	65	10	74	33	216	75	131.6	6.6	35	20	M5	10	1/5
HC-MF43BG2	400	115	95	135	100	8	75	10	85	35	237	85	152.6	9	40	25	M6	12	1/9
HC-MF43BG2	400	135	110	155	115	8	90	12	100	40	243	100	158.6	11	50	32	M8	16	1/20
HC-MF43BG2	400	135	110	155	115	8	90	12	100	40	243	100	158.6	11	50	32	M8	16	1/29



# 10. SPECIFICATIONS

Model	Output (W)	Braking Force (N·m)	Reduction Gear Model	Reduction Ratio	Inertia Moment J( $\times 10^{-4}$ kg·m <sup>2</sup> )	Weight (kg)
HC-MF73BG2	750	2.4	BK3-05B-08MEKA	1/5	1.098	7.3
HC-MF73BG2	750	2.4	BK4-09B-08MEKA	1/9	1.105	9.6
HC-MF73BG2	750	2.4	BK5-20B-08MEKA	1/20	1.141	13.0
HC-MF73BG2	750	2.4	BK5-29B-08MEKA	1/29	1.035	13.0

Model	Output (W)	Variable Dimensions																	(Reduction Ratio)
		LA	LB	LC	LD	LE	LF	LG	LH	LK	L	LR	KL	LZ	Q	S	P	R	
HC-MF73BG2	750	115	95	135	100	8	75	10	85	35	247.5	85	156.7	9	40	25	M6	12	1/5
HC-MF73BG2	750	135	110	155	115	8	90	12	100	40	283.5	100	192.7	11	50	32	M8	16	1/9
HC-MF73BG2	750	150	125	175	130	10	105	15	115	43	283.5	115	192.7	14	60	40	M10	20	1/20
HC-MF73BG2	750	150	125	175	130	10	105	15	115	43	283.5	115	192.7	14	60	40	M10	20	1/29

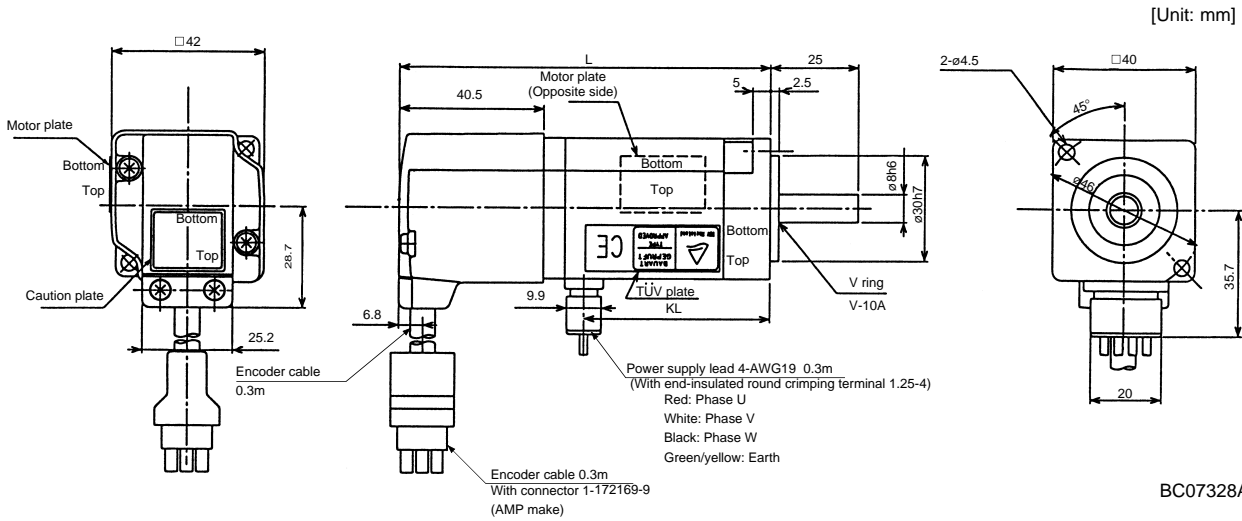


# 10. SPECIFICATIONS

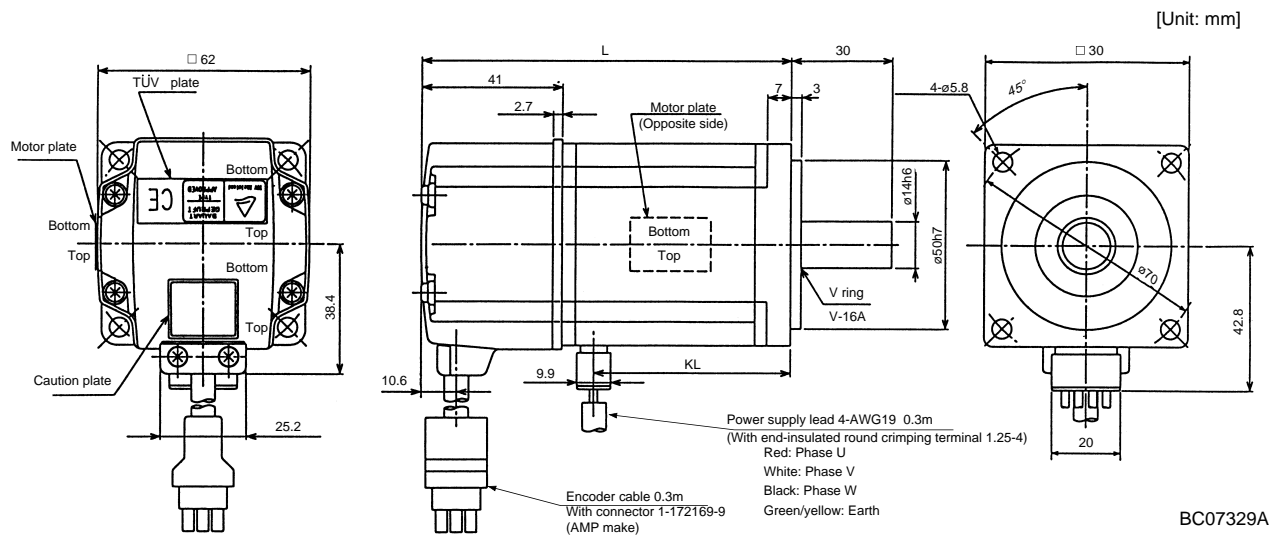
## (2) HC-MF-UE series

### 1) Standard (Without electromagnetic brake, without reduction gear)

Model	Output (W)	Variable Dimensions		Inertia Moment $J(\times 10^{-4} \text{kg}\cdot\text{m}^2)$	Weight (kg)
		L	KL		
HC-MF053-UE	50	89.5	37.5	0.019	0.5
HC-MF13-UE	100	104.5	52.5	0.03	0.6



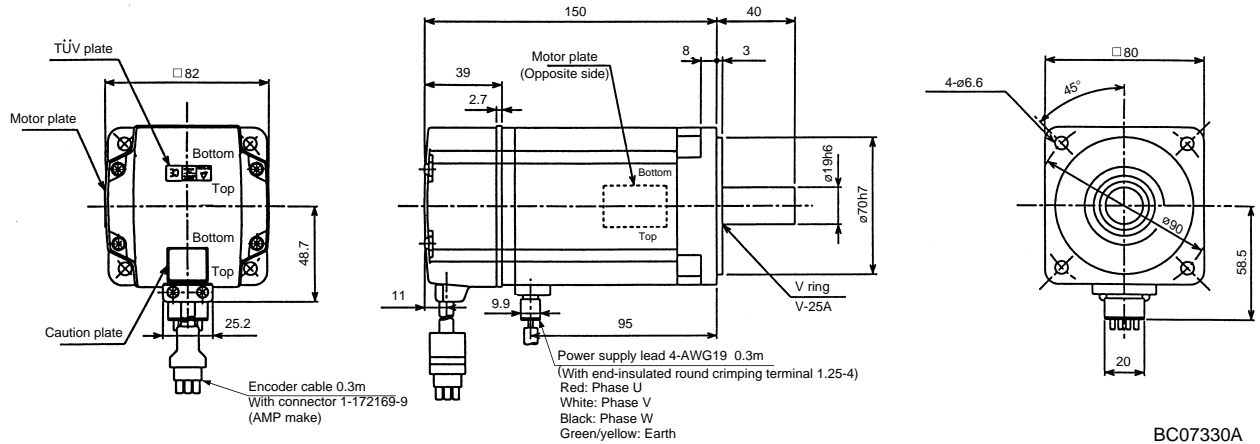
Model	Output (W)	Variable Dimensions		Inertia Moment $J(\times 10^{-4} \text{kg}\cdot\text{m}^2)$	Weight (kg)
		L	KL		
HC-MF23-UE	200	108.5	58	0.09	1.2
HC-MF43-UE	400	133.5	81	0.14	1.7



# 10. SPECIFICATIONS

Model	Output (W)	Inertia Moment $J(\times 10^{-4} \text{kg}\cdot\text{m}^2)$	Weight (kg)
HC-MF73-UE	750	0.675	3.1

[Unit: mm]

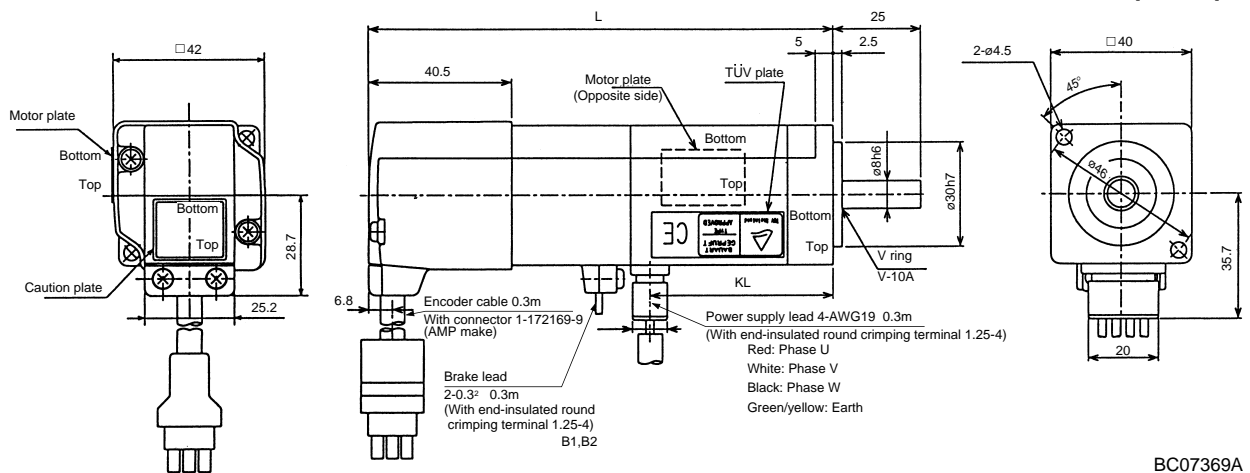


BC07330A

## 2) With electromagnetic brake

Model	Output (W)	Variable Dimensions		Barking Force (N·m)	Inertia Moment $J(\times 10^{-4} \text{kg}\cdot\text{m}^2)$	Weight (kg)
		L	KL			
HC-MF053B-UE	50	117.5	37.5	0.32	0.022	0.9
HC-MF13B-UE	100	132.5	52.5	0.32	0.032	1

[Unit: mm]

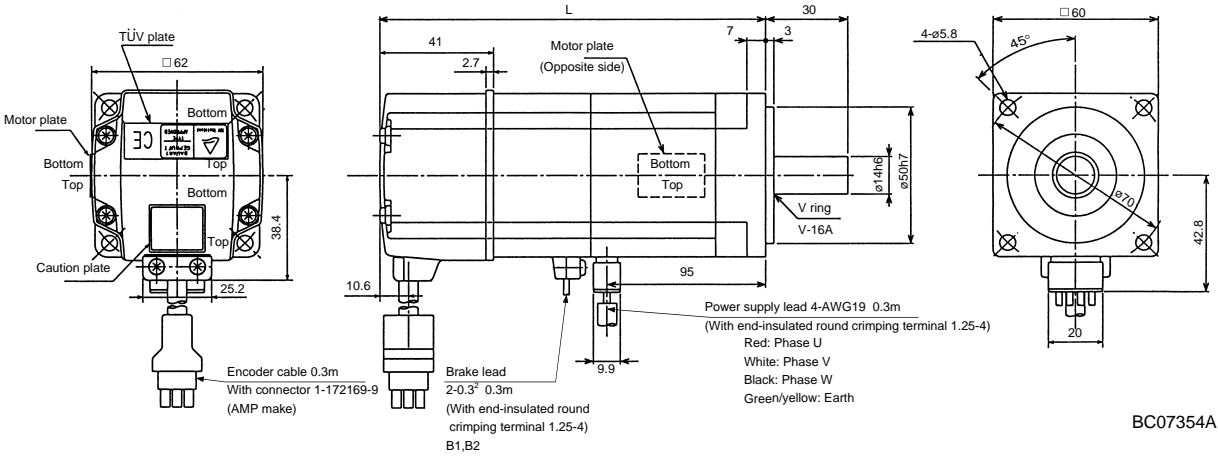


BC07369A

# 10. SPECIFICATIONS

Model	Output (W)	Variable Dimensions		Barking Force (N•m)	Inertia Moment $J(\times 10^{-4} \text{kg}\cdot\text{m}^2)$	Weight (kg)
		L	KL			
HC-MF23B-UE	200	140.5	58	1.3	0.136	1.7
HC-MF43B-UE	400	165.5	81	1.3	0.191	2.2

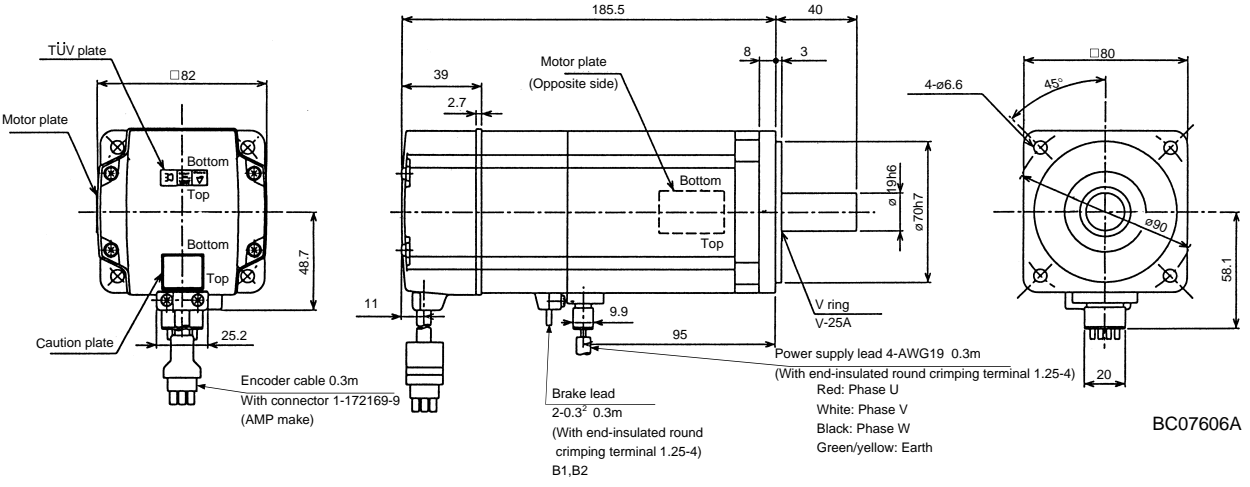
[Unit: mm]



BC07354A

Model	Output (W)	Barking Force (N•m)	Inertia Moment $J(\times 10^{-4} \text{kg}\cdot\text{m}^2)$	Weight (kg)
HC-MF73B-UE	750	2.4	0.75	4.2

[Unit: mm]



BC07606A



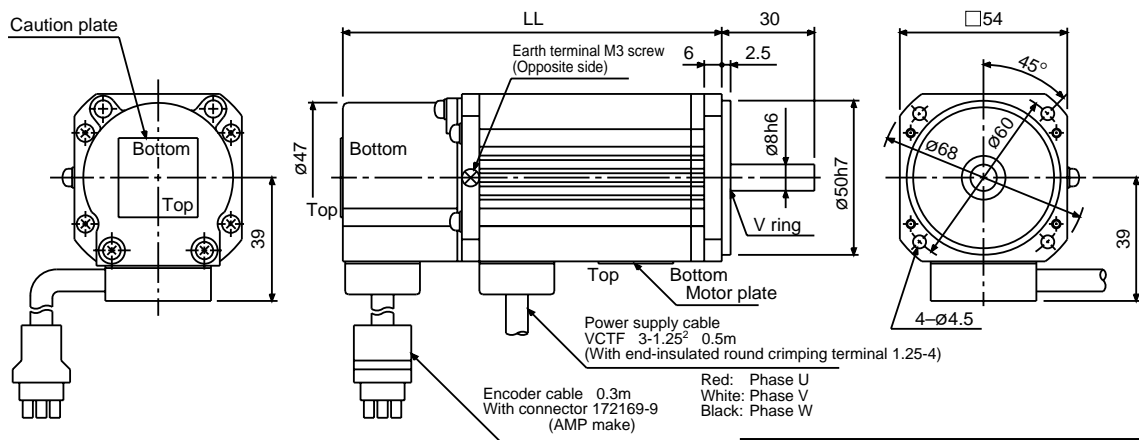
# 10. SPECIFICATIONS

## (3) HA-FF series

### 1) Standard

HA – FF053 • HA – FF13

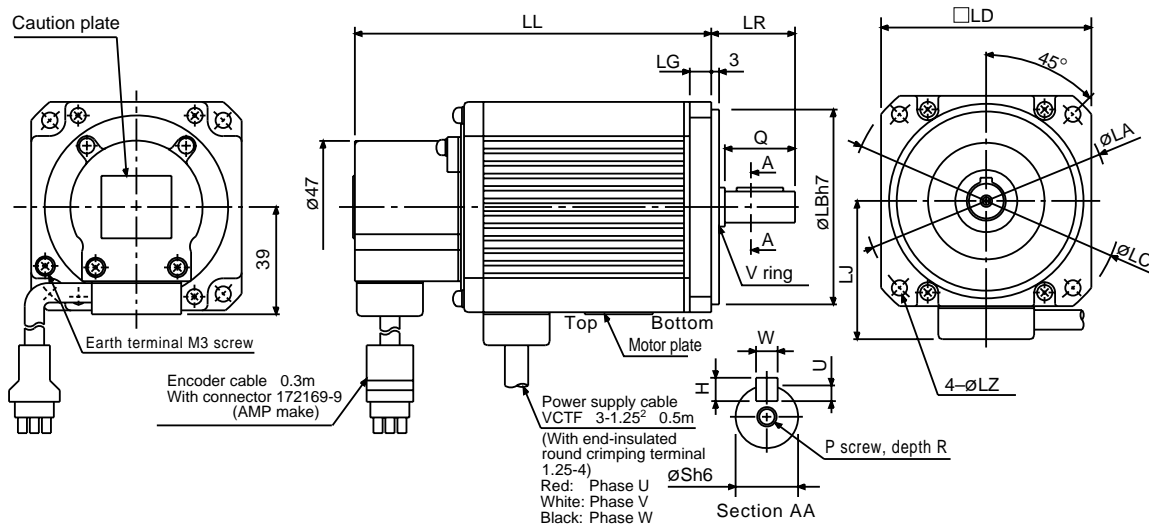
[Unit: mm]



Servo Motor Model	Inertia Moment $J[\times 10^{-4} \text{kg}\cdot\text{m}^2]$	Variable Dimensions LL	Weight [kg]
HA-FF053	0.063	106	1.3
HA-FF13	0.10	123	1.5

HA – FF23 to HA – FF63

[Unit: mm]



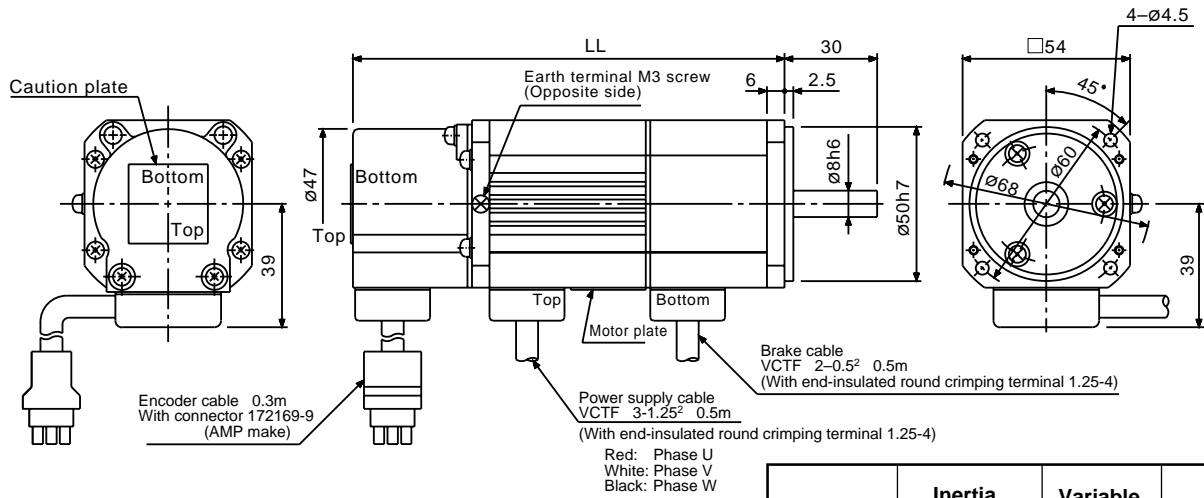
Servo Motor Model	Inertia Moment $J[\times 10^{-4} \text{kg}\cdot\text{m}^2]$	Variable Dimensions															Weight [kg]	
		LA	LB	LC	LD	LG	LJ	LL	LR	LZ	H	Q	S	U	W	P		R
HA-FF23	0.35	90	70	100	76	8	50	131	30	5.5	4	25	11	2.5	4	M4 x 0.7	15	2.3
HA-FF33	0.5	90	70	100	76	8	50	148	30	5.5	4	25	11	2.5	4	M4 x 0.7	15	2.6
HA-FF43	0.98	115	95	135	100	10	62	154.5	40	9	5	35	16	3	5	M5 x 0.8	20	4.2
HA-FF63	1.2	115	95	135	100	10	62	169.5	40	9	5	35	16	3	5	M5 x 0.8	20	4.8

# 10. SPECIFICATIONS

## 2) With electromagnetic brake

HA – FF053B • HA – FF13B

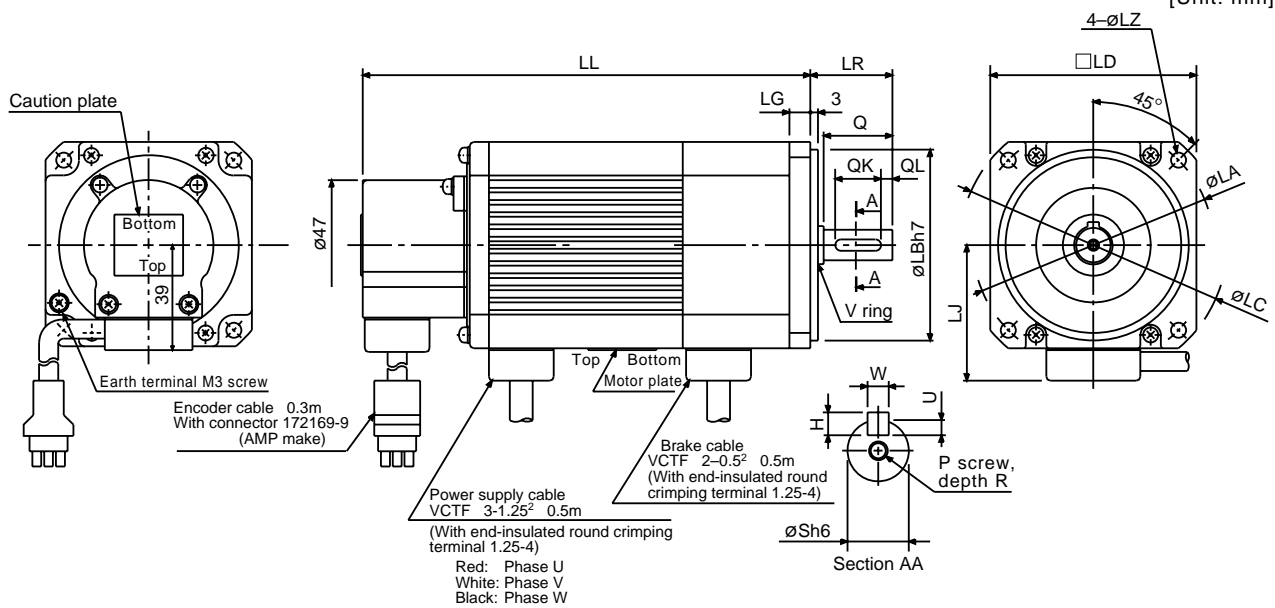
[Unit: mm]



Servo Motor Model	Inertia Moment $J[\times 10^{-4} \text{kg}\cdot\text{m}^2]$	Variable Dimensions LL	Weight [kg]
HA-FF053	0.08	140.5	1.6
HA-FF13B	0.11	157.5	1.8

HA – FF23B to HA – FF63B

[Unit: mm]



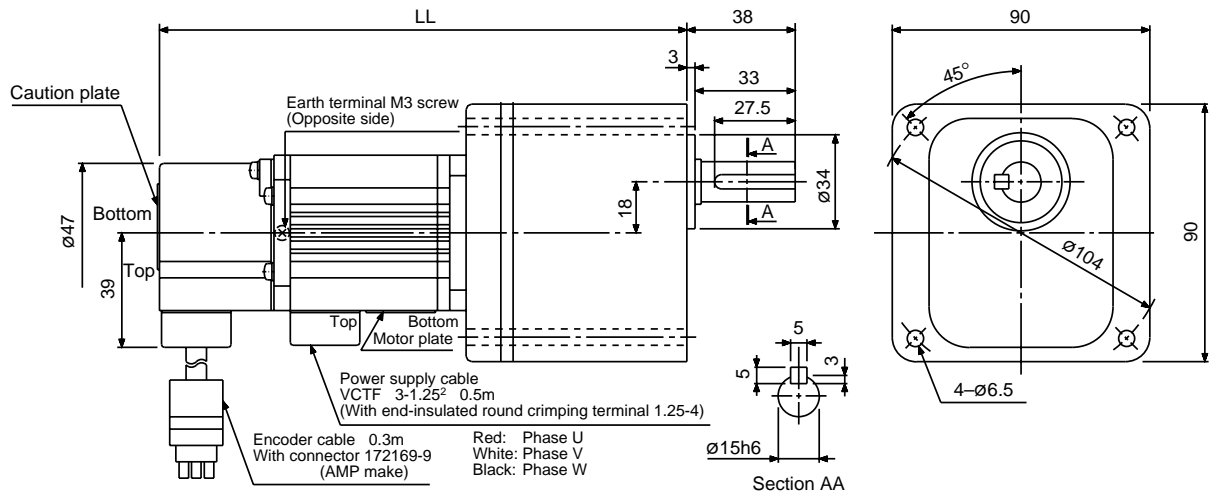
Servo Motor Model	Inertia Moment $J[\times 10^{-4} \text{kg}\cdot\text{m}^2]$	Variable Dimensions																Weight [kg]		
		LA	LB	LC	LD	LG	LJ	LL	LR	LZ	H	Q	S	U	W	QK	QL		P	R
HA-FF23B	0.48	90	70	100	76	8	50	167.5	30	5.5	8	25	11	2.5	4	16	4	M4 x 0.7	15	2.9
HA-FF33B	0.63	90	70	100	76	8	50	185	30	5.5	8	25	11	2.5	4	16	4	M4 x 0.7	15	3.2
HA-FF43B	1.33	115	95	135	100	10	62	191.5	40	9	5	35	16	3	5	25	5	M5 x 0.8	20	5.0
HA-FF63B	1.55	115	95	135	100	10	62	206.5	40	9	5	35	16	3	5	25	5	M5 x 0.8	20	5.6

# 10. SPECIFICATIONS

## 3) With reduction gear for general industrial machine

HA – FF053(B)G1 • HA – FF13(B)G1

[Unit: mm]

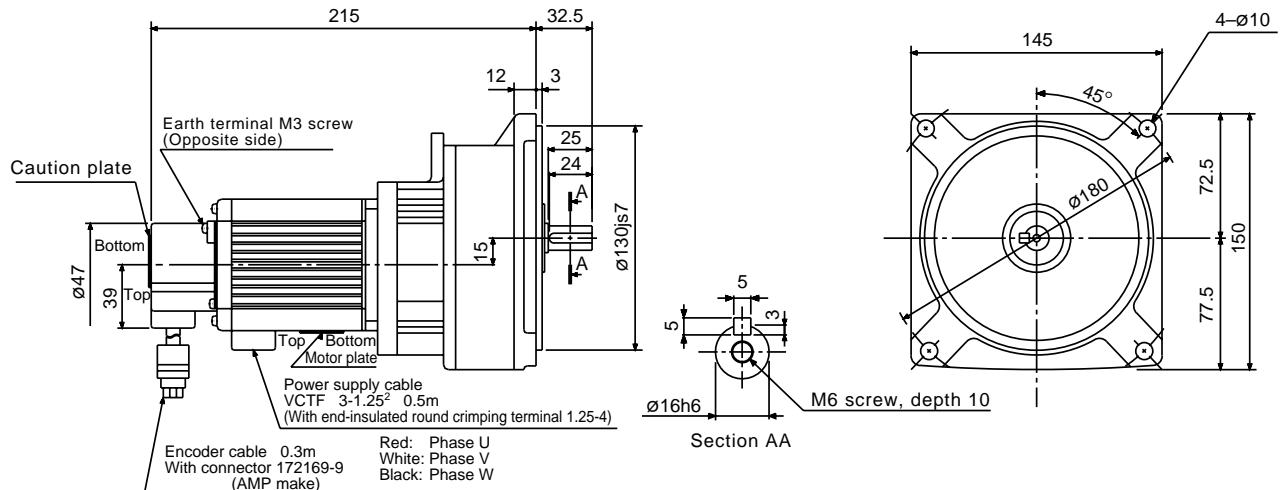


Servo Motor Model	(Note 2) Reduction Ratio	Reduction Gear Model	(Note 1) Inertia Moment J [ $\times 10^{-4} \text{kg}\cdot\text{m}^2$ ]	(Note 1) Variable Dimensions LL	(Note 1) Weight [kg]
HA-FF053 (B)G1	1/5	GR-S-10	0.068 (0.084)	183 (217.5)	2.5 (2.8)
	1/10		0.068 (0.084)	183 (217.5)	2.5 (2.8)
	1/30		0.063 (0.080)	183 (217.5)	2.5 (2.8)
HA-FF13 (B)G1	1/5	GR-S-10	0.10 (0.115)	200 (234.5)	2.7 (3.0)
	1/10		0.10 (0.115)	200 (234.5)	2.7 (3.0)
	1/30		0.095 (0.11)	200 (234.5)	2.7 (3.0)

Note: 1. Values in parentheses are those for the servo motors with electromagnetic brakes.  
2. Nominal reduction ratios. For actual reduction ratios, refer to Section 10-3.

HA – FF23(B)G1

[Unit: mm]



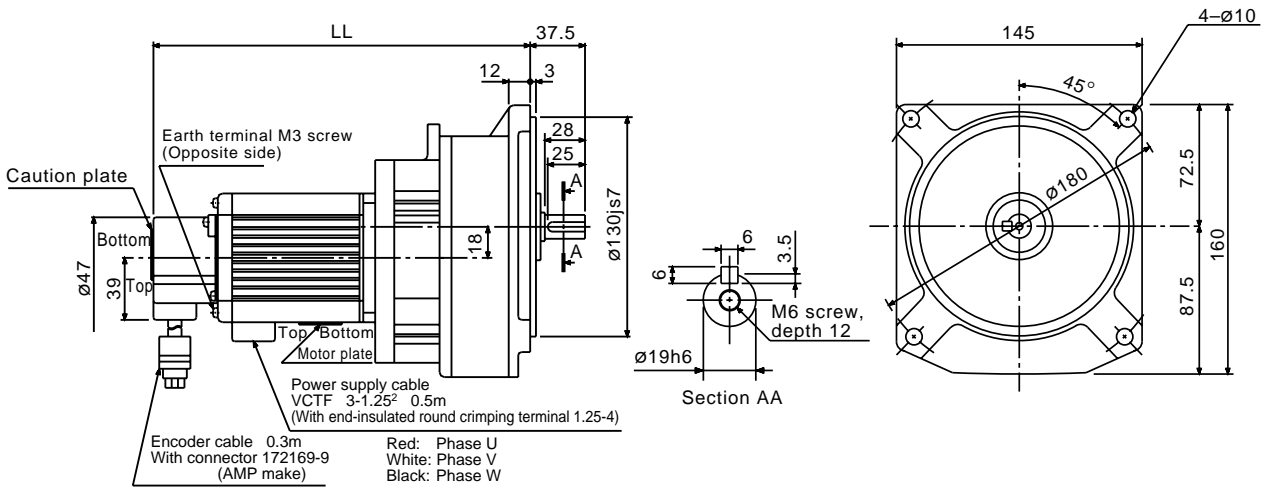
Servo Motor Model	(Note 2) Reduction Ratio	Reduction Gear Model	(Note 1) Inertia Moment J [ $\times 10^{-4} \text{kg}\cdot\text{m}^2$ ]	(Note 1) Weight [kg]
HA-FF23 (B)G1	1/5	GR-S-20	0.373 (0.502)	5.0 (5.6)
	1/10		0.373 (0.502)	5.0 (5.6)
	1/30		0.37 (0.50)	5.0 (5.6)

Note: 1. Values in parentheses are those for the servo motors with electromagnetic brakes.  
2. Nominal reduction ratios. For actual reduction ratios, refer to Section 10-3.

# 10. SPECIFICATIONS

HA – FF33(B)G1 • HA – FF43(B)G1

[Unit: mm]

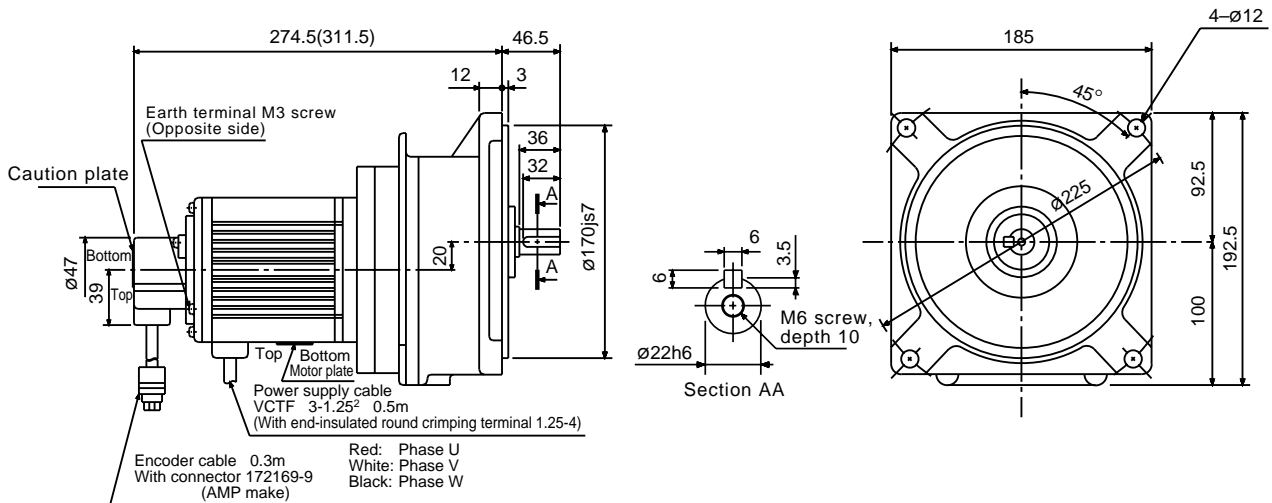


Servo Motor Model	(Note 2) Reduction Ratio	Reduction Gear Model	(Note 1) Inertia Moment J [ $\times 10^{-4}$ kg $\cdot$ m $^2$ ]	(Note 1) Variable Dimensions LL	(Note 1) Weight [kg]
HA-FF33 (B)G1	1/5	GR-S-30	0.545 (0.678)	250 (287)	6.5 (7.2)
	1/10		0.545 (0.678)	250 (287)	6.5 (7.2)
	1/30		0.538 (0.670)	250 (287)	6.5 (7.2)
HA-FF43 (B)G1	1/5	GR-S-40	1.02 (1.37)	259 (295.5)	8.0 (8.9)
	1/10		1.02 (1.37)	259 (295.5)	8.0 (8.9)
	1/30		1.01 (1.36)	259 (295.5)	8.0 (8.9)

Note: 1. Values in parentheses are those for the servo motors with electromagnetic brakes.  
 2. Nominal reduction ratios. For actual reduction ratios, refer to Section 10-3.

HA – FF63(B)G1

[Unit: mm]



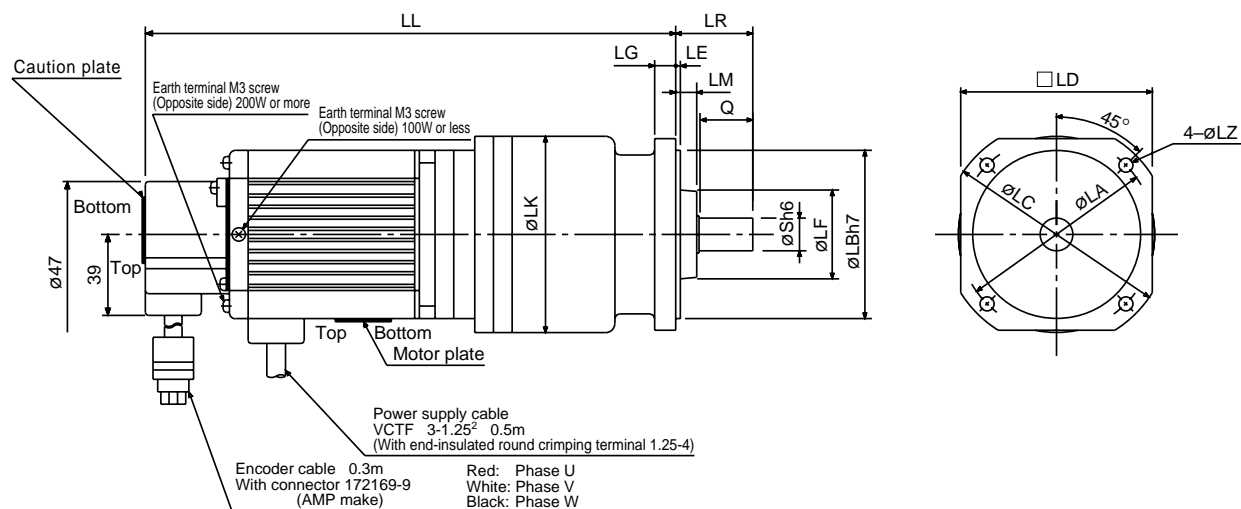
Servo Motor Model	(Note 2) Reduction Ratio	Reduction Gear Model	(Note 1) Inertia Moment J [ $\times 10^{-4}$ kg $\cdot$ m $^2$ ]	(Note 1) Weight [kg]
HA-FF63 (B)G1	1/5	GR-S-60	1.34 (1.69)	13.0 (13.9)
	1/10		1.34 (1.69)	13.0 (13.9)
	1/30		1.32 (1.67)	13.0 (13.9)

Note: 1. Values in parentheses are those for the servo motors with electromagnetic brakes.  
 2. Nominal reduction ratios. For actual reduction ratios, refer to Section 10-3.

# 10. SPECIFICATIONS

## 4) With reduction gear for precision application

[Unit: mm]

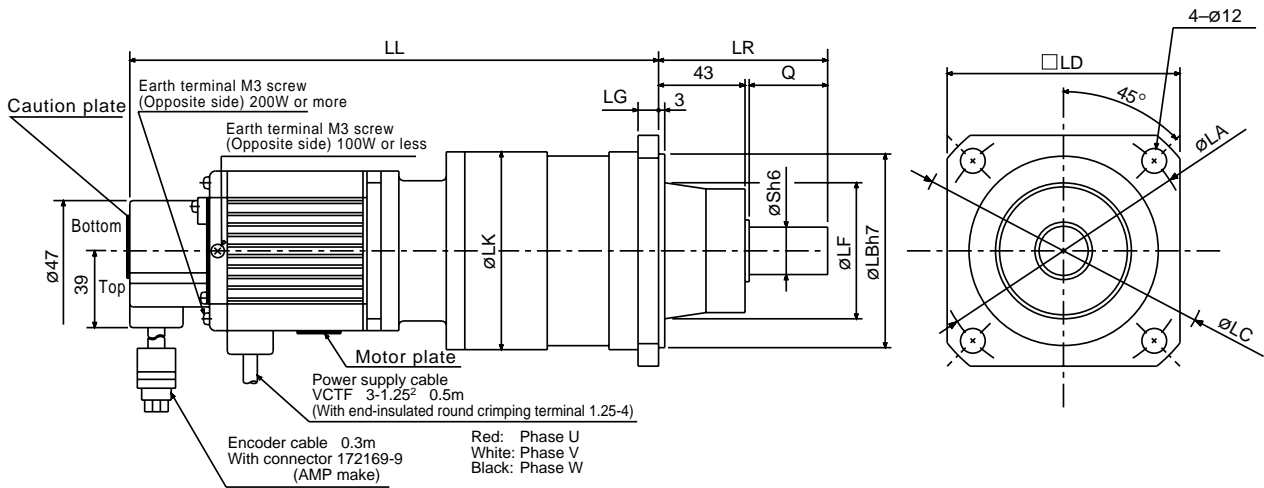


Servo Motor Model	Reduction Ratio	Reduction Gear Model	(Note) Inertia Moment J [X 10 <sup>-4</sup> kg·m <sup>2</sup> ]	(Note) Variable Dimensions													(Note) Weight [kg]	
				LA	LB	LC	LD	LE	LF	LG	LK	LL	LM	LR	LZ	Q		S
HA-FF053 (B)G2	1/5	BM2-05B -A5MES	0.11 (0.128)	78	62	89	74	2	33	6	75	205 (240)	9	30	4.5	20	10	2.3 (2.6)
	1/10	BM2-10B -A5MES	0.108 (0.125)	78	62	89	74	2	33	6	75	205 (239.5)	9	30	4.5	20	10	2.3 (2.6)
	1/15	BM2-15B -A5MES	0.105 (0.123)	78	62	89	74	2	33	6	75	205 (239.5)	9	30	4.5	20	10	2.3 (2.6)
	1/25	BM3-25B -A5MES	0.111 (0.120)	90	76	102	87	2	41	8	87	213 (247.5)	9	35	5.5	25	14	2.8 (3.2)
HA-FF13 (B)G2	1/5	BM2-05B -01MES	0.143 (0.160)	78	62	89	74	2	33	6	75	222 (256.5)	9	30	4.5	20	10	2.5 (2.8)
	1/10	BM3-10B -01MES	0.165 (0.160)	90	76	102	87	2	41	8	87	230 (264.5)	9	35	5.5	25	14	3.0 (3.4)
	1/15	BM3-15B -01MES	0.155 (0.153)	90	76	102	87	2	41	8	87	230 (264.5)	9	35	5.5	25	14	3.0 (3.4)
	1/25	BM4-25B -01MES	0.29 (0.308)	122	100	140	118	3	61	10	118	262 (296.5)	14	55	6.6	40	22	5.0 (5.3)
HA-FF23 (B)G2	1/5	BM3-05B -02MES	0.425 (0.558)	90	76	102	87	2	41	8	87	240 (277)	9	35	5.5	25	14	3.8 (4.4)
	1/10	BM4-10B -02MES	0.645 (0.778)	122	100	140	118	3	61	10	118	270 (306.5)	14	55	6.6	40	22	5.8 (6.4)
	1/15	BM4-15B -02MES	0.618 (0.75)	122	100	140	118	3	61	10	118	270 (306.5)	14	55	6.6	40	22	5.8 (6.4)
HA-FF33 (B)G2	1/5	BM4-05B -03MES	0.818 (0.95)	122	100	140	118	3	61	10	118	287 (324.5)	14	55	6.6	40	22	6.1 (6.7)
	1/10	BM4-10B -03MES	0.795 (0.928)	122	100	140	118	3	61	10	118	287 (324.5)	14	55	6.6	40	22	6.1 (6.7)
HA-FF43 (B)G2	1/5	BM4-05B -04MES	1.293 (1.643)	122	100	140	118	3	61	10	118	304 (340.5)	14	55	6.6	40	22	7.7 (8.5)

Note: Values in parentheses are those for the servo motors with electromagnetic brakes.

# 10. SPECIFICATIONS

[Unit: mm]



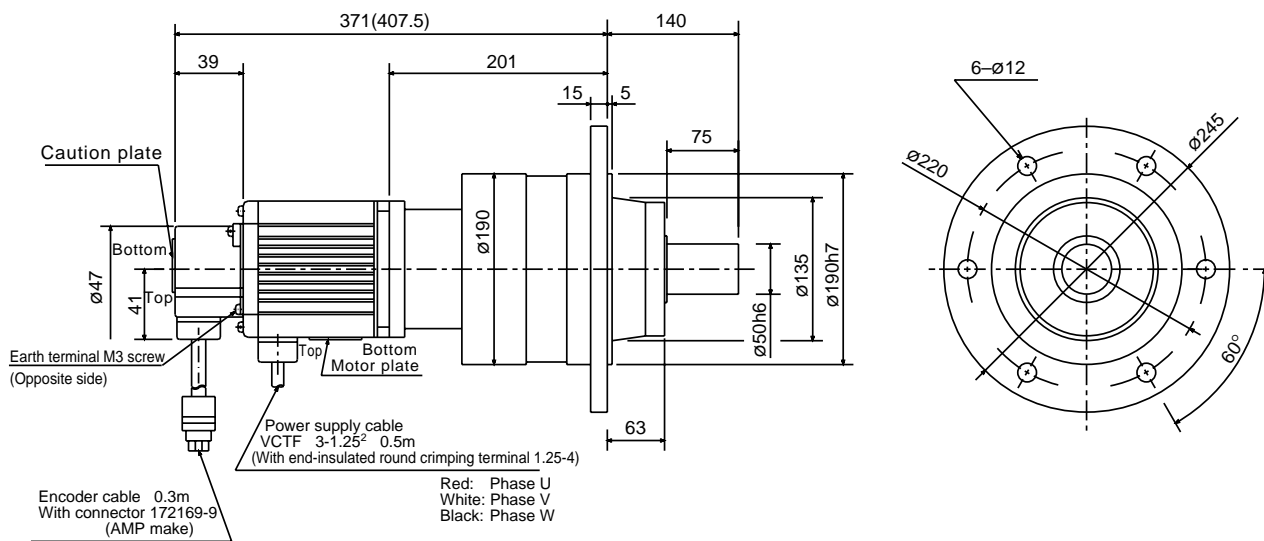
Servo Motor Model	Reduction Ratio	Reduction Gear Model	(Note) Inertia Moment J[×10 <sup>-4</sup> kg·m <sup>2</sup> ]	(Note) Variable Dimensions										(Note) Weight [kg]	
				LA	LB	LC	LD	LF	LG	LK	LL	LR	Q		S
HA-FF13 (B)G2	1/45	BL1-45B-01MES	0.293 (0.298)	130	100	155	120	70	10	102	274 (308.5)	85	40	25	6 (6.3)
HA-FF23 (B)G2	1/20	BL1-20B-02MES	0.730 (0.885)	130	100	155	120	70	10	102	278 (311.5)	85	40	25	6.8 (7.4)
	1/29	BL1-29B-02MES	0.633 (0.765)	130	100	155	120	70	10	102	278 (314.5)	85	40	25	6.8 (7.4)
HA-FF33 (B)G2	1/45	BL2-45B-02MES	0.763 (0.895)	160	130	185	140	94	12	132	299 (336)	100	55	35	12.3 (12.9)
	1/20	BL1-20B-03MES	0.880 (1.013)	130	100	155	120	70	10	102	295 (329.5)	85	40	25	7.1 (7.7)
	1/29	BL2-29B-03MES	1.535 (1.668)	160	130	185	140	94	12	132	316 (353.5)	100	55	35	12.6 (13.2)
HA-FF43 (B)G2	1/45	BL2-45B-03MES	0.913 (1.045)	160	130	185	140	94	12	132	316 (363.5)	100	55	35	12.6 (13.2)
	1/9	BL1-09B-04MES	1.193 (1.543)	130	100	155	120	70	10	102	295.5 (332.5)	85	40	25	8.2 (9.0)
	1/20	BL2-20B-04MES	2.378 (2.623)	160	130	185	140	94	12	132	323.5 (360.5)	100	55	35	14.2 (15)
HA-FF63 (B)G2	1/29	BL2-29B-04MES	2.01 (2.36)	160	130	185	140	94	12	132	323.5 (360.5)	100	55	35	14.2 (15)
	1/45	BL2-45B-04MES	1.388 (1.738)	160	130	185	140	94	12	132	333.5 (370.5)	100	55	35	14.2 (15)
	1/5	BL1-05B-06MES	1.283 (1.858)	130	100	155	120	70	10	102	300.5 (337.5)	85	40	25	8.8 (9.6)
	1/9	BL1-09B-06MES	1.418 (1.768)	130	100	155	120	70	10	102	310.5 (347.5)	85	40	25	8.8 (9.6)
HA-FF63 (B)G2	1/20	BL2-20B-06MES	2.603 (2.953)	160	130	185	140	94	12	132	338.5 (375.5)	100	55	35	14.8 (15.6)
	1/29	BL2-29B-06MES	2.235 (2.585)	160	130	185	140	94	12	132	338.5 (375.5)	100	55	35	14.8 (15.6)

Note: Values in parentheses are those for the servo motors with electromagnetic brakes.

# 10. SPECIFICATIONS

HA – FF63(B)G2 1/45

[Unit: mm]



Reduction Gear Model	Reduction Ratio	(Note) Inertia Moment J [ $\times 10^{-4} \text{kg}\cdot\text{m}^2$ ]	(Note) Weight [kg]
BL3-45B-06MES	1/45	3.13 (3.475)	29.8 (33.7)

Note: Values in parentheses are those for the servo motors with electromagnetic brakes.

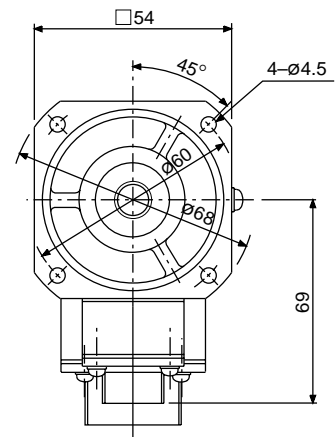
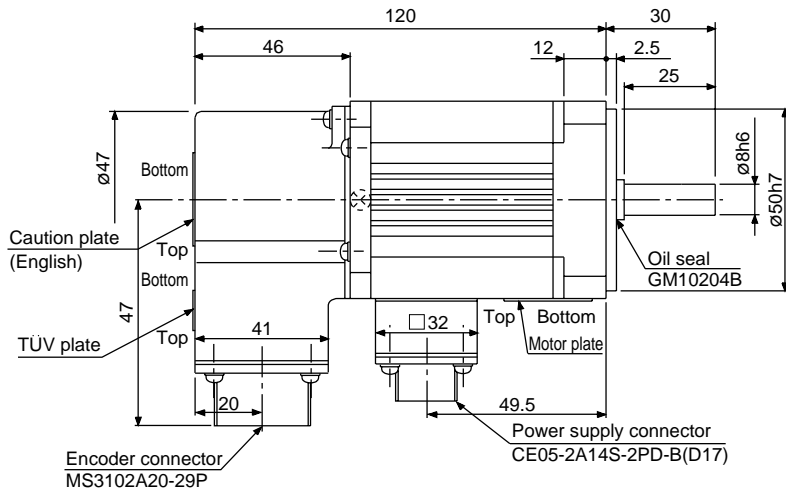
# 10. SPECIFICATIONS

## (4) HA-FFC-UE series

### 1) Standard (without electromagnetic brake, without reduction gear)

HA – FF053C – UE

[Unit: mm]

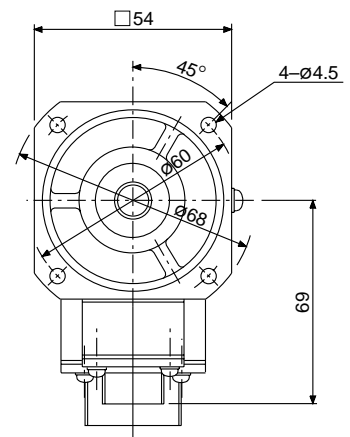
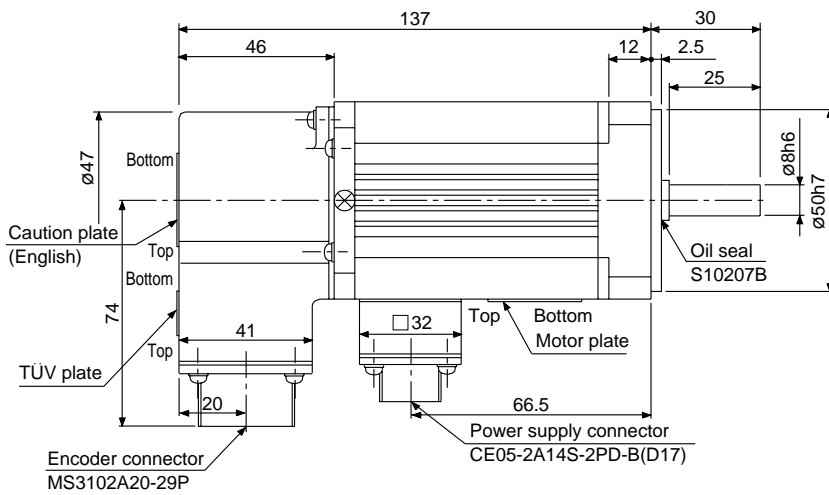


Model	Output [W]	Inertia Moment J [X10 <sup>-4</sup> kg·m <sup>2</sup> ]	Weight [kg]
HA-FF053C-UE	50	0.063	1.8

- Note: 1. For the pin-outs of the power supply and encoder connectors, refer to (3), Section 3-2-3.  
 2. For horizontal installation, it is recommended to face the power supply and encoder connectors down.

HA – FF13C – UE

[Unit: mm]



Model	Output [W]	Inertia Moment J [X10 <sup>-4</sup> kg·m <sup>2</sup> ]	Weight [kg]
HA-FF13C-UE	100	0.10	2

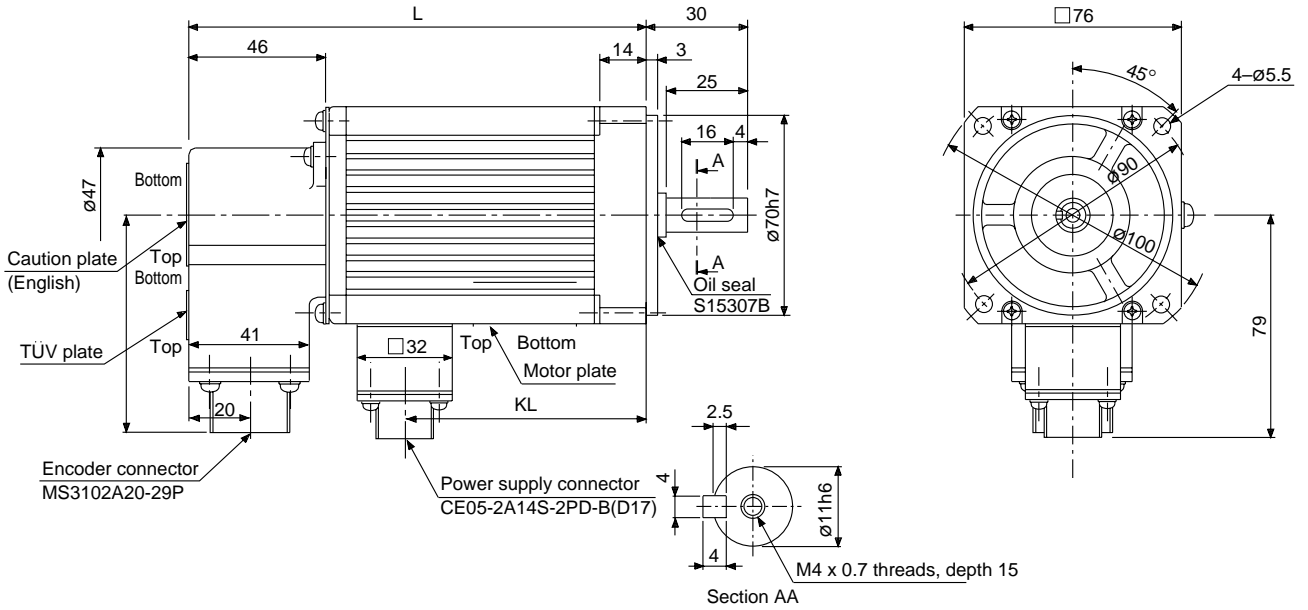
- Note: 1. For the pin-outs of the power supply and encoder connectors, refer to (3), Section 3-2-3.  
 2. For horizontal installation, it is recommended to face the power supply and encoder connectors down.



# 10. SPECIFICATIONS

HA – FF23C – UE • HA – FF33C – UE

[Unit: mm]

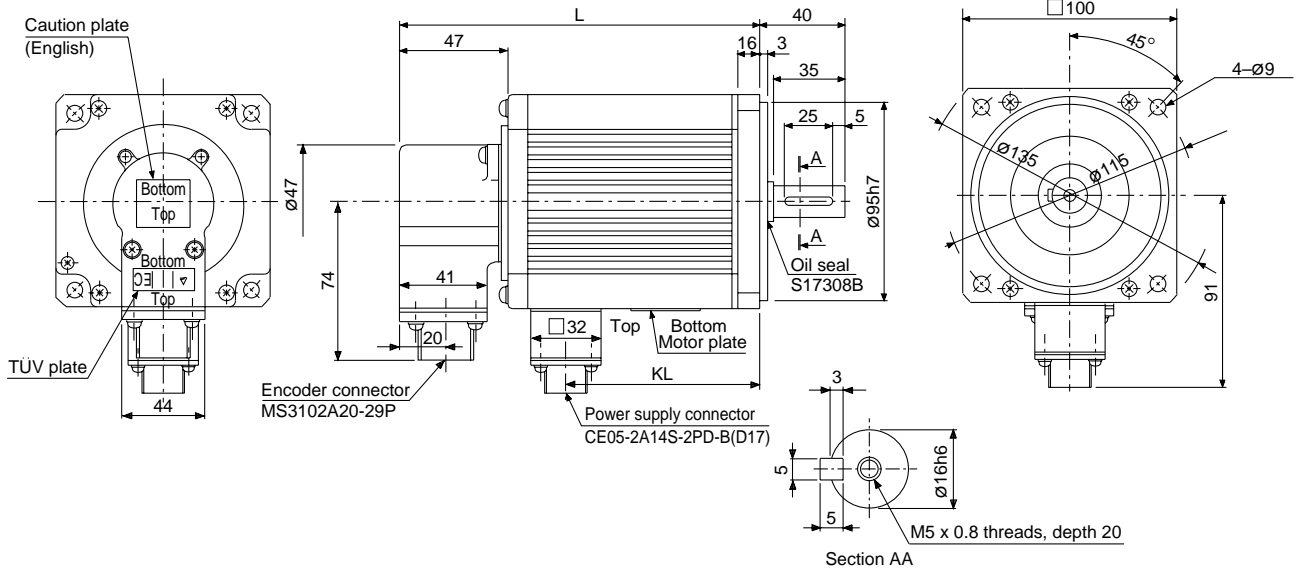


- Note: 1. For the pin-outs of the power supply and encoder connectors, refer to (3), Section 3-2-3.  
 2. For horizontal installation, it is recommended to face the power supply and encoder connectors down.

Model	Output [W]	Variable Dimensions		Inertia Moment J [X 10 <sup>-4</sup> kg·m <sup>2</sup> ]	Weight [kg]
		L	KL		
HA-FF23C-UE	200	145	71.5	0.35	2.6
HA-FF33C-UE	300	162	89	0.50	2.9

HA – FF43C – UE • HA – FF63C – UE

[Unit: mm]



- Note: 1. For the pin-outs of the power supply and encoder connectors, refer to (3), Section 3-2-3.  
 2. For horizontal installation, it is recommended to face the power supply and encoder connectors down.

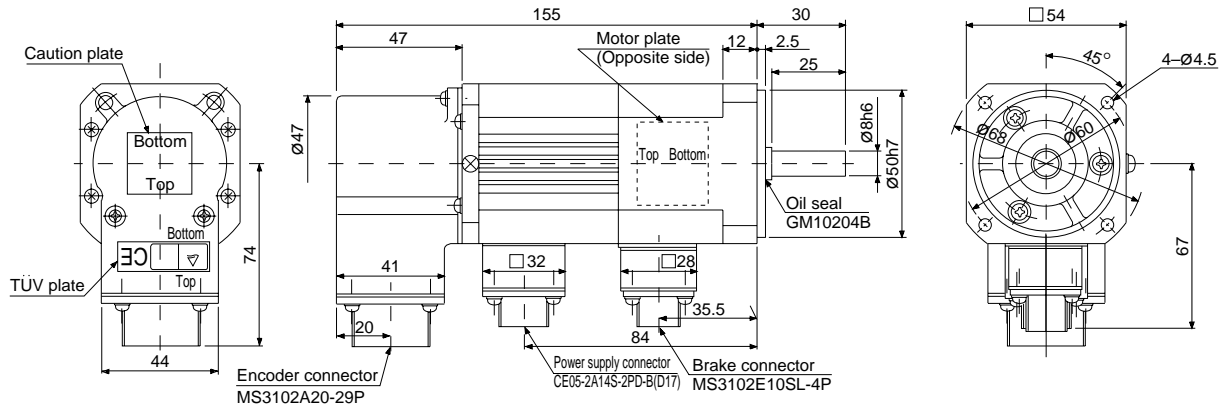
Model	Output [W]	Variable Dimensions		Inertia Moment J [X 10 <sup>-4</sup> kg·m <sup>2</sup> ]	Weight [kg]
		L	KL		
HA-FF43C-UE	400	169	93	0.98	4.7
HA-FF63C-UE	600	184	108	1.2	5.3

# 10. SPECIFICATIONS

## 2) With electromagnetic brake

HA – FF053CB – UE

[Unit: mm]

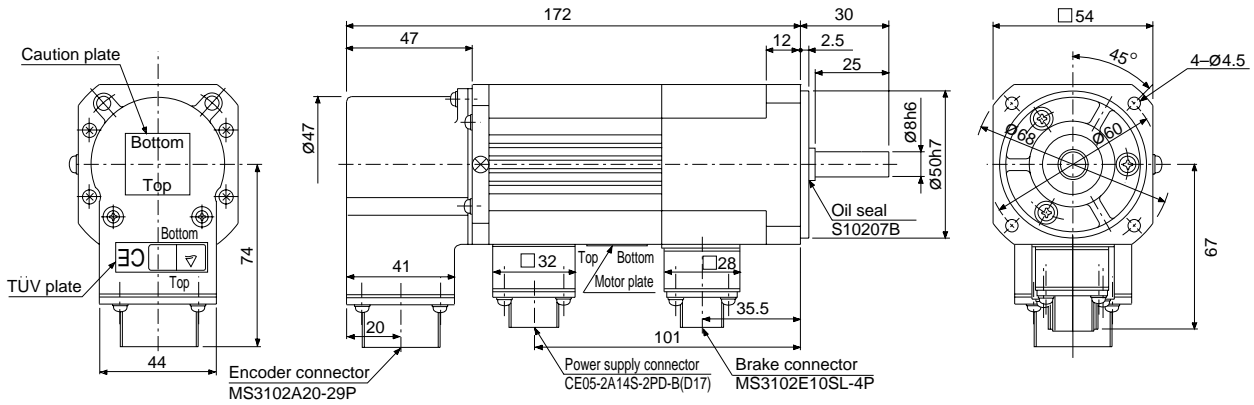


- Note: 1. For the pin-outs of the power supply and encoder connectors, refer to (3), Section 3-2-3.  
 2. For horizontal installation, it is recommended to face the power supply and encoder connectors down.

Model	Output [W]	Inertia Moment J [X 10 <sup>-4</sup> kg·m <sup>2</sup> ]	Braking Force [N·m]	Weight [kg]
HA-FF053CB-UE	50	0.08	0.39	2.1

HA – FF13CB – UE

[Unit: mm]



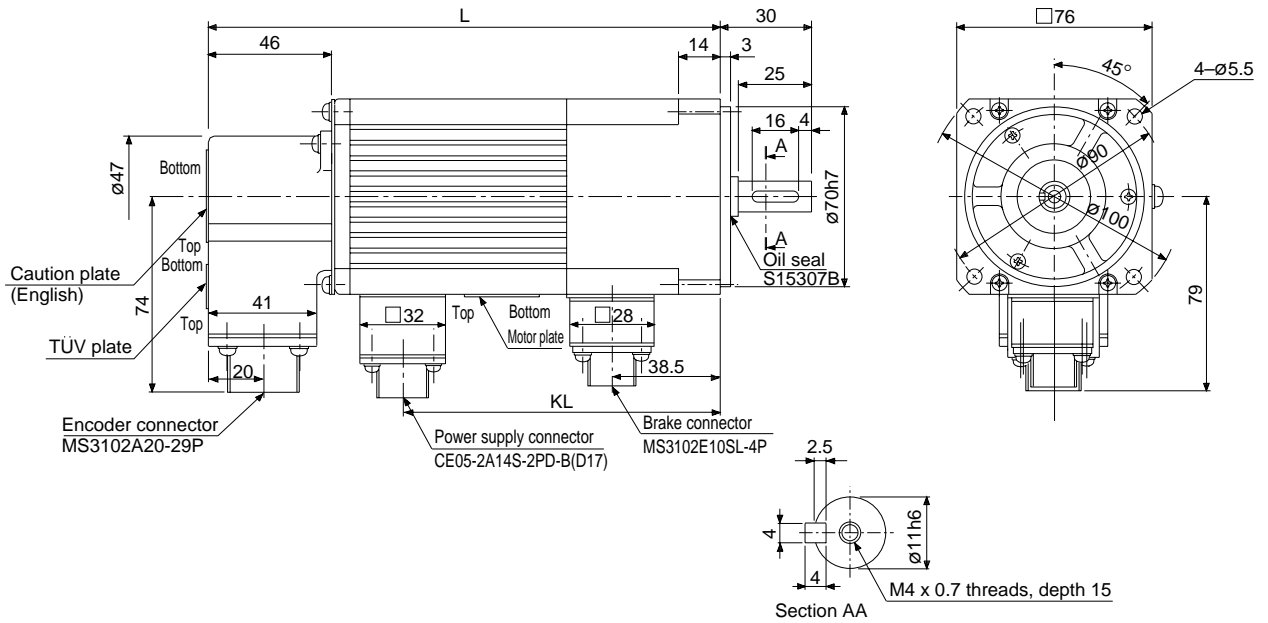
- Note: 1. For the pin-outs of the power supply and encoder connectors, refer to (3), Section 3-2-3.  
 2. For horizontal installation, it is recommended to face the power supply and encoder connectors down.

Model	Output [W]	Inertia Moment J [X 10 <sup>-4</sup> kg·m <sup>2</sup> ]	Braking Force [N·m]	Weight [kg]
HA-FF13CB-UE	100	0.11	0.39	2.3

# 10. SPECIFICATIONS

HA – FF23CB – UE • HA – FF33CB – UE

[Unit: mm]

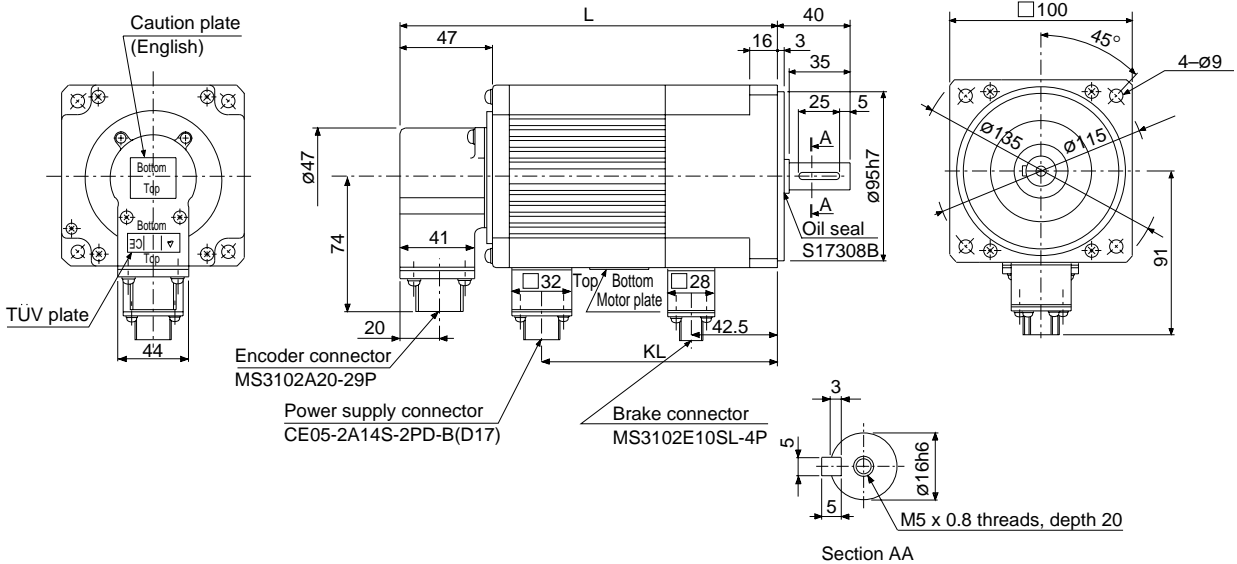


Note: 1. For the pin-outs of the power supply and encoder connectors, refer to (3), Section 3-2-3.  
 2. For horizontal installation, it is recommended to face the power supply and encoder connectors down.

Model	Output [W]	Variable Dimensions		Braking Force [N·m]	Inertia Moment J [× 10 <sup>-4</sup> kg·m <sup>2</sup> ]	Weight [kg]
		L	KL			
HA-FF23CB-UE	200	182	109	1.2	0.48	3.5
HA-FF33CB-UE	300	200	127		0.63	3.8

HA – FF43CB – UE • HA – FF63CB – UE

[Unit: mm]



Note: 1. For the pin-outs of the power supply and encoder connectors, refer to (3), Section 3-2-3.  
 2. For horizontal installation, it is recommended to face the power supply and encoder connectors down.

Model	Output [W]	Variable Dimensions		Braking Force [N·m]	Inertia Moment J [× 10 <sup>-4</sup> kg·m <sup>2</sup> ]	Weight [kg]
		L	KL			
HA-FF43CB-UE	400	206	130	2.3	1.33	5.8
HA-FF63CB-UE	600	221	145		1.55	6.4

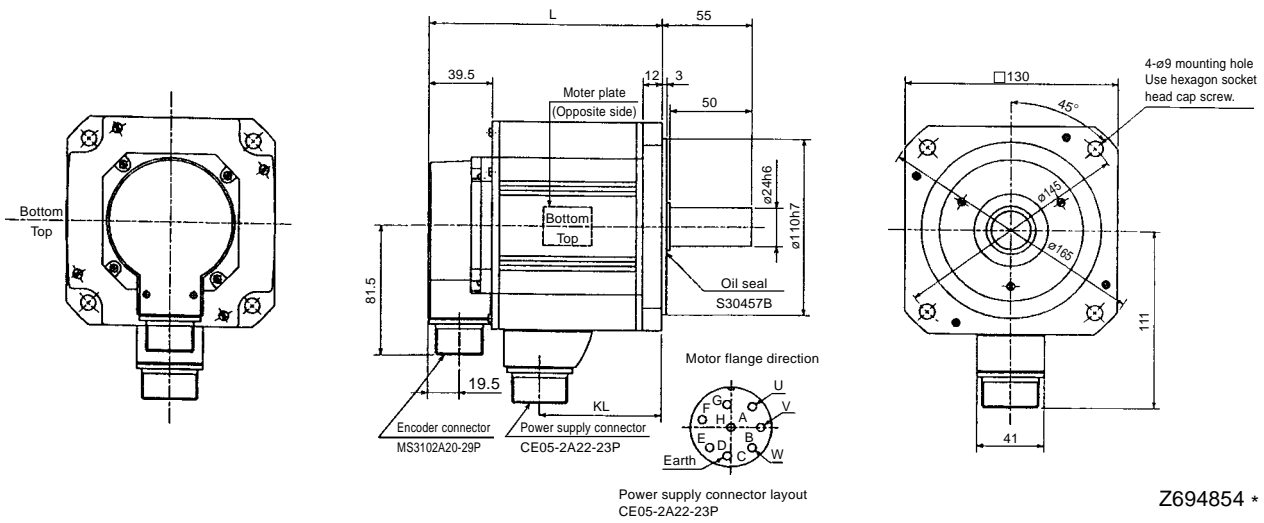
# 10. SPECIFICATIONS

(5) HC-SF series

1) Standard (without electromagnetic brake, without reduction gear)

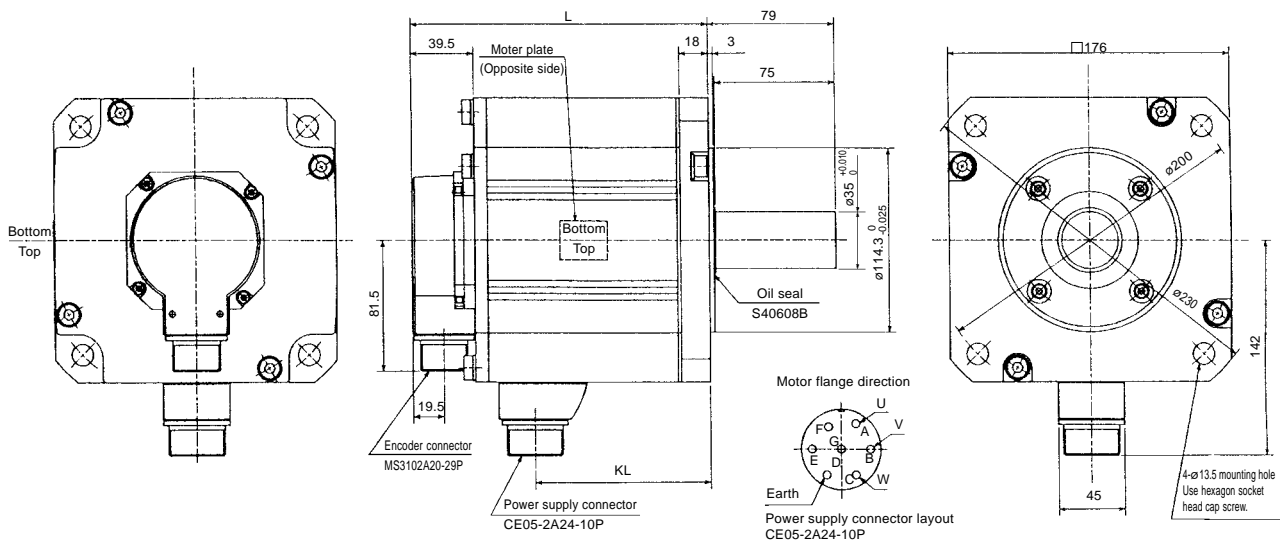
Model	Output (kW)	Variable Dimensions		Inertia Moment $J(\times 10^{-4} \text{kg}\cdot\text{m}^2)$	Weight (kg)
		L	KL		
HC-SF52 HC-SF53	0.5	120	51.5	6.6	5.0
HC-SF102 HC-SF103	1.0	145	76.5	13.7	7.0
HC-SF81	0.85	170	101.5	20	9.0
HC-SF152 HC-SF153	1.5				

[Unit: mm]



Model	Output (kW)	Variable Dimensions		Inertia Moment $J(\times 10^{-4} \text{kg}\cdot\text{m}^2)$	Weight (kg)
		L	KL		
HC-SF121	1.2	145	68.5	42.5	12.0
HC-SF202 HC-SF203	2.0				
HC-SF201	2.0	187	110.5	82.0	19.0
HC-SF352 HC-SF353	3.5				

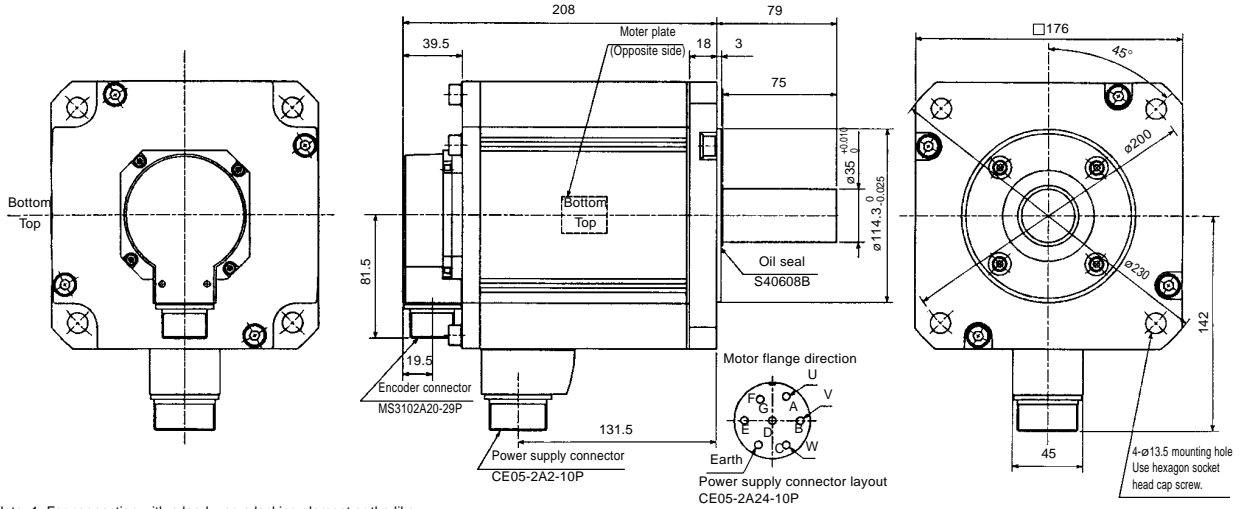
[Unit: mm]



# 10. SPECIFICATIONS

Model	Output (kW)	Inertia Moment $J(\times 10^{-4} \text{kg}\cdot\text{m}^2)$	Weight (kg)
HC-SF301	3.0	101	23

[Unit: mm]



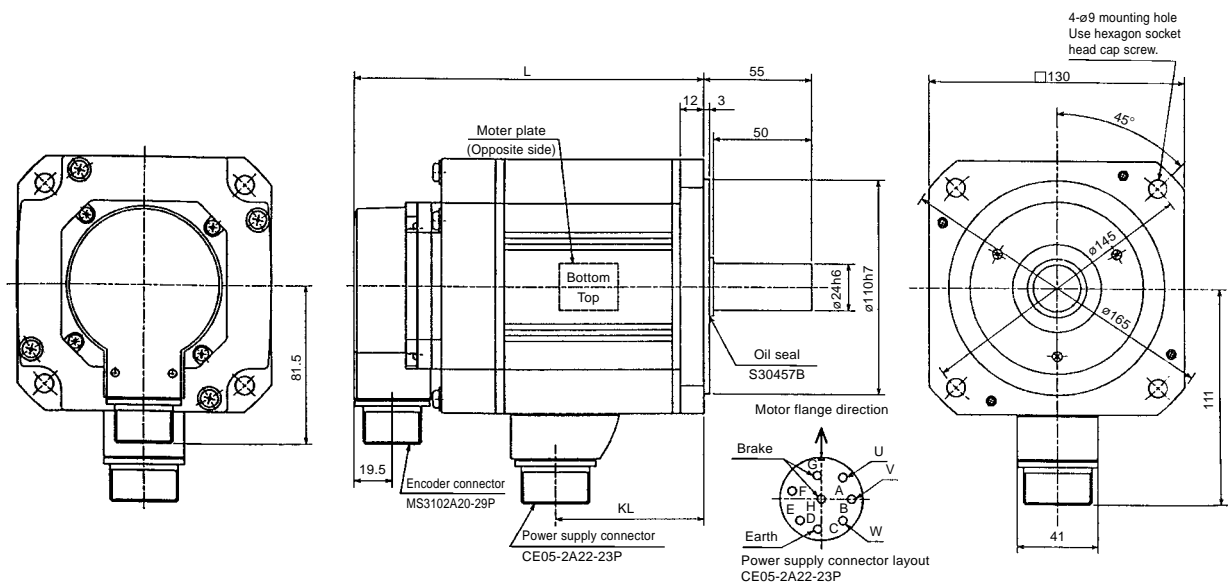
Note: 1. For connection with a load, use a locking element or the like.

BC10628 \*

## 2) With electromagnetic brake

Model	Output (kW)	Variable Dimensions		Braking Force (N·m)	Inertia Moment $J(\times 10^{-4} \text{kg}\cdot\text{m}^2)$	Weight (kg)
		L	KL			
HC-SF52B HC-SF53B	0.5	153	51.5	8.5	8.3	7.5
HC-SF102B HC-SF103B	1.0	178	76.5	8.5	15.4	9.5
HC-SF81B	0.85	203	101.5	8.5	21.7	11.5
HC-SF152B HC-SF153B	1.5					

[Unit: mm]

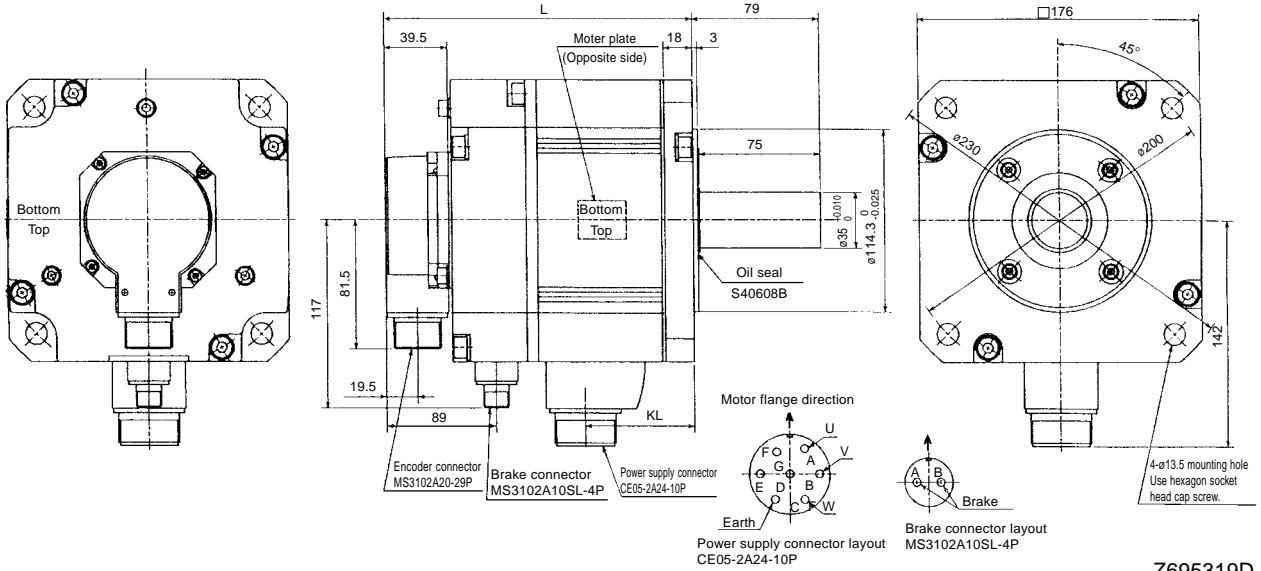


Z695005

# 10. SPECIFICATIONS

Model	Output (kW)	Variable Dimensions		Braking Force (N·m)	Inertia Moment $J(\times 10^{-4} \text{kg}\cdot\text{m}^2)$	Weight (kg)
		L	KL			
HC—SF121B	1.2	193	68.5	43.1	52.5	18.0
HC—SF202B HC—SF203B	2.0					
HC—SF201B	2.0	235	110.5	43.1	92.0	25.0
HC—SF352B HC—SF353B	3.5					

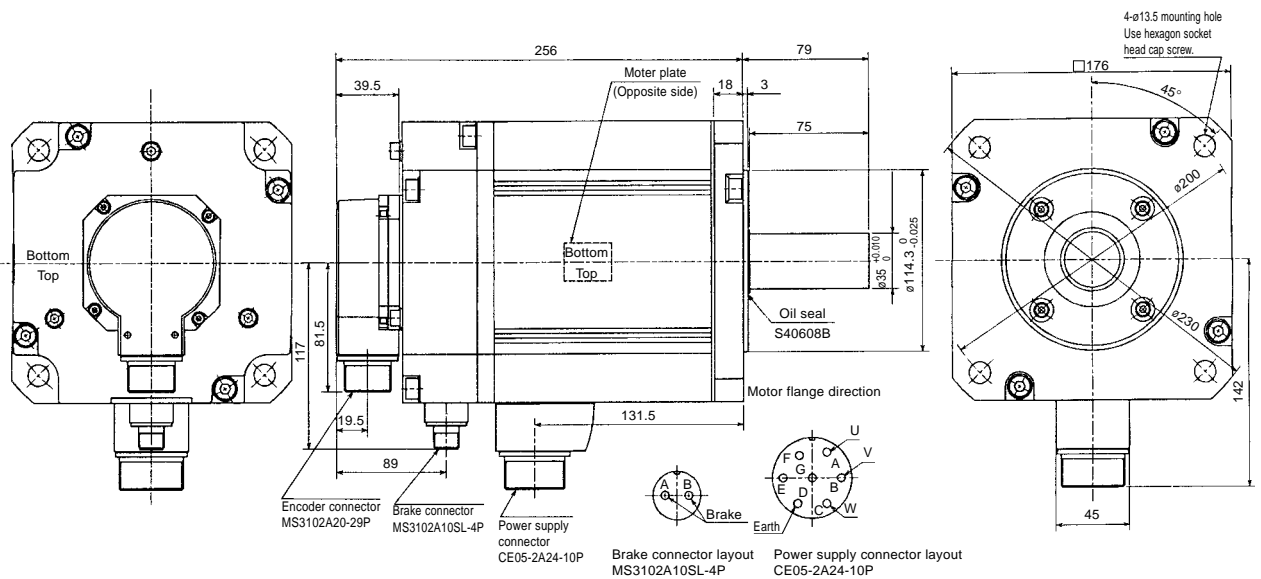
[Unit: mm]



Z695319D

Model	Output (kW)	Braking Force (N·m)	Inertia Moment $J(\times 10^{-4} \text{kg}\cdot\text{m}^2)$	Weight (kg)
HC—SF301B	3.0	43.1	111	29.0

[Unit: mm]



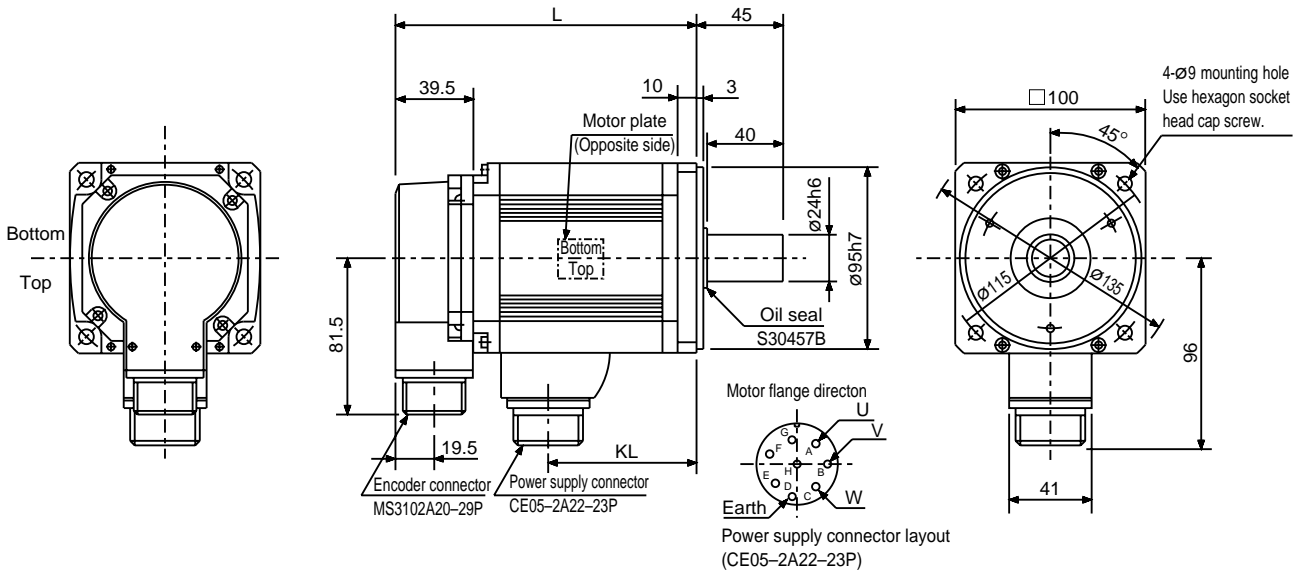
BC10823 \*

# 10. SPECIFICATIONS

## (6) HC-RF series

### 1) Standard (without electromagnetic brake, without reduction gear)

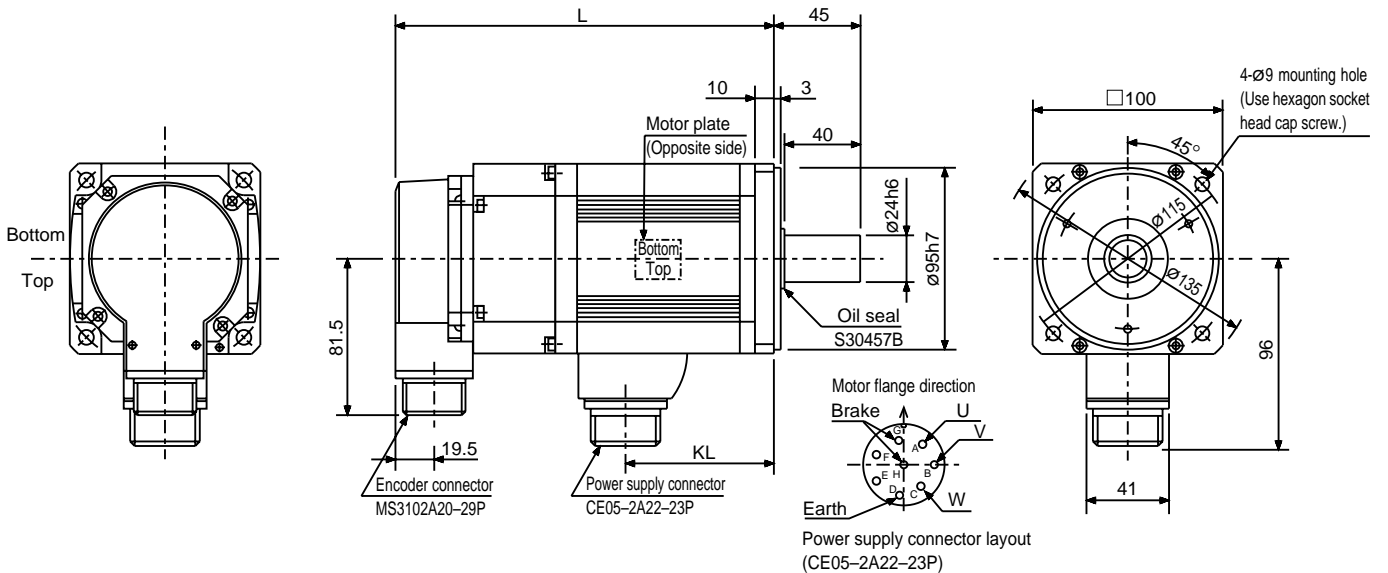
[Unit: mm]



Model	Output (kW)	Variable Dimensions		Inertia Moment $J(\times 10^{-4} \text{kg}\cdot\text{m}^2)$	Weight (kg)
		L	KL		
HC-RF103	1.0	147	71	1.5	3.9
HC-RF153	1.5	172	96	1.9	5.0
HC-RF203	2.0	197	121	2.3	6.2

### 2) With electromagnetic brake

[Unit: mm]



Model	Output (kW)	Variable Dimensions		Barking Force (N•m)	Inertia Moment $J(\times 10^{-4} \text{kg}\cdot\text{m}^2)$	Weight (kg)
		L	KL			
HC-RF103B	1.0	185	71	7	1.85	6.0
HC-RF153B	1.5	210	96	7	2.25	7.0
HC-RF203B	2.0	235	121	7	2.65	8.3

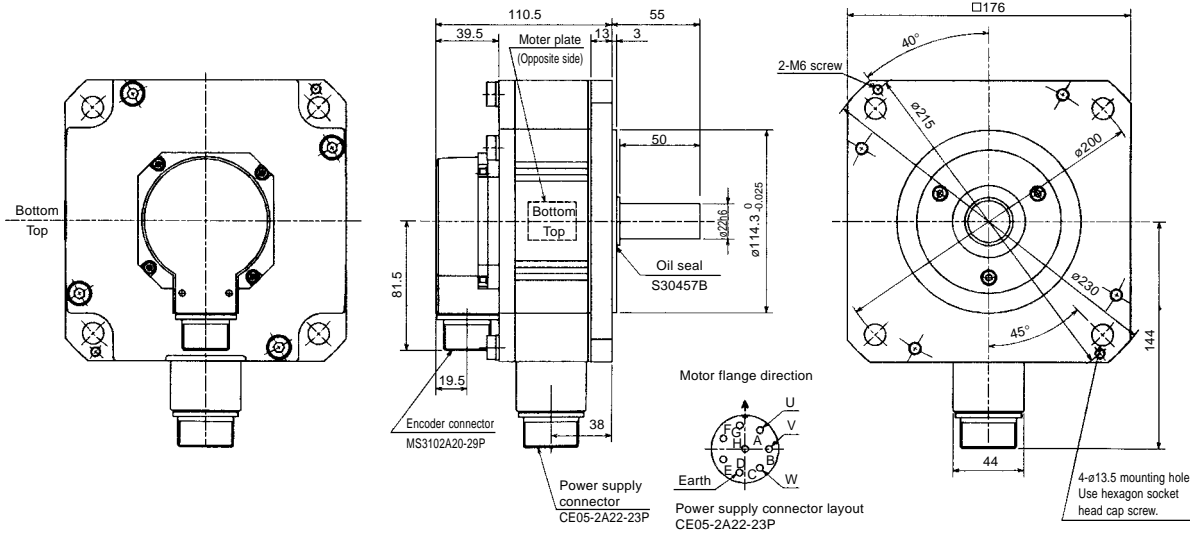
# 10. SPECIFICATIONS

## (7) HC-UF series

### 1) Standard (without electromagnetic brake)

Model	Output (kW)	Inertia Moment $J(\times 10^{-4} \text{kg}\cdot\text{m}^2)$	Weight (kg)
HC-UF72	0.75	10.4	8

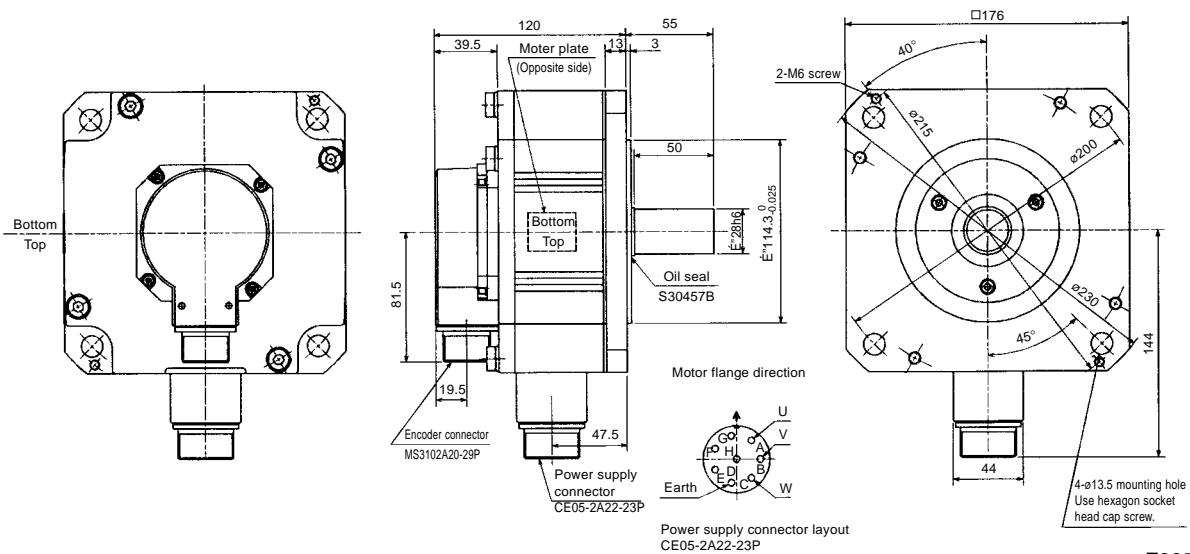
[Unit: mm]



Z695911 \*

Model	Output (kW)	Inertia Moment $J(\times 10^{-4} \text{kg}\cdot\text{m}^2)$	Weight (kg)
HC-UF152	1.5	22.1	11

[Unit: mm]



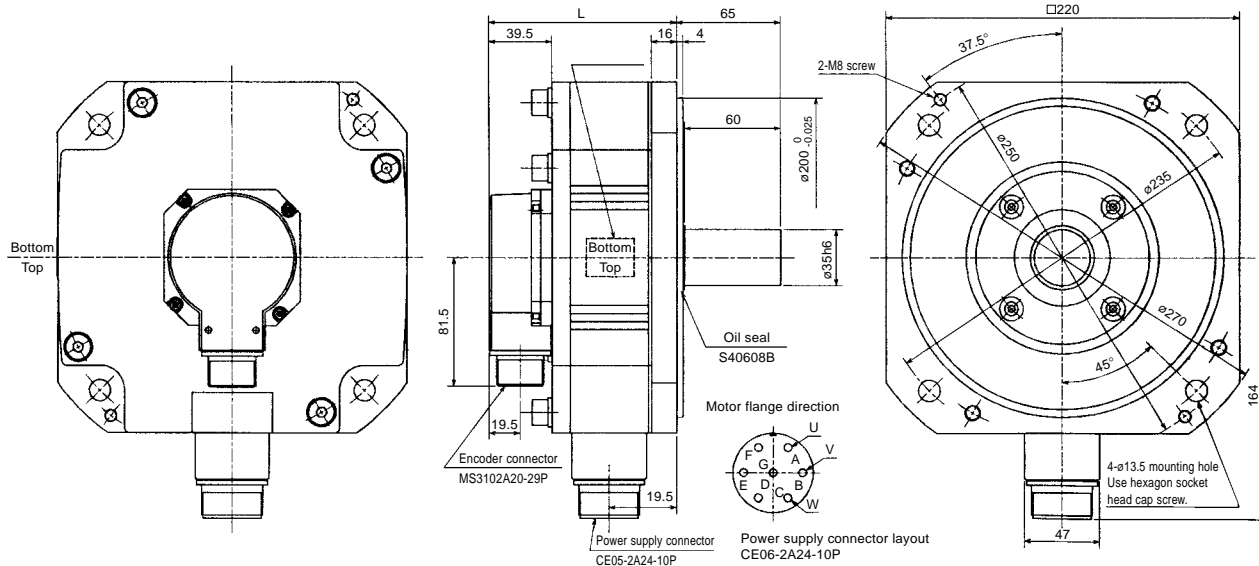
Z695912A



# 10. SPECIFICATIONS

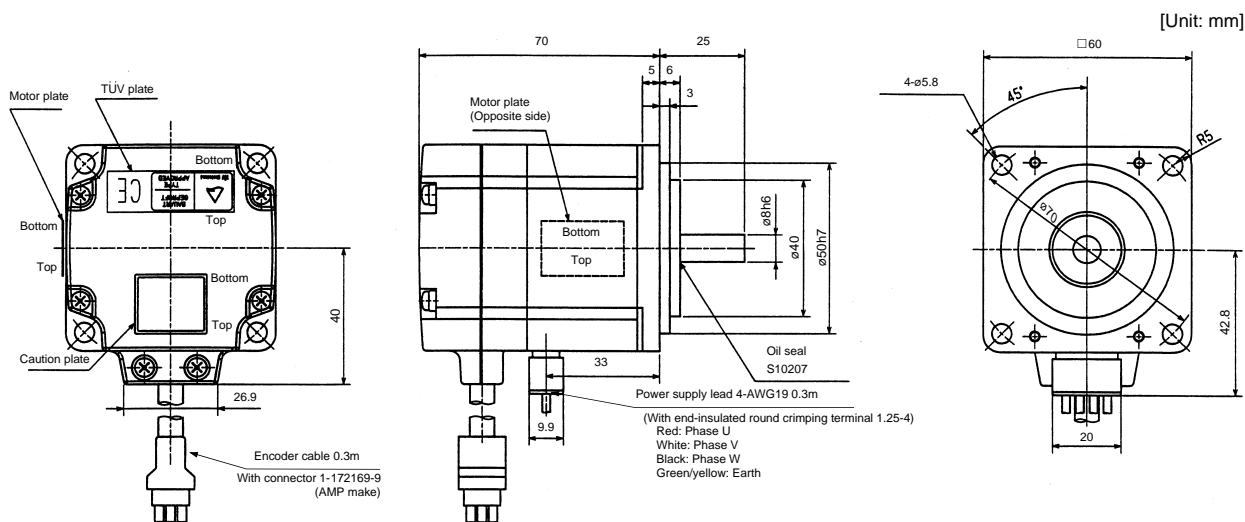
Model	Output (kW)	Variable Dimensions		Inertia Moment $J(\times 10^{-4} \text{kg}\cdot\text{m}^2)$	Weight (kg)
		L	KL		
HC-UF202	2.0	118	42.5	38.2	16

[Unit: mm]



Z695914 \*

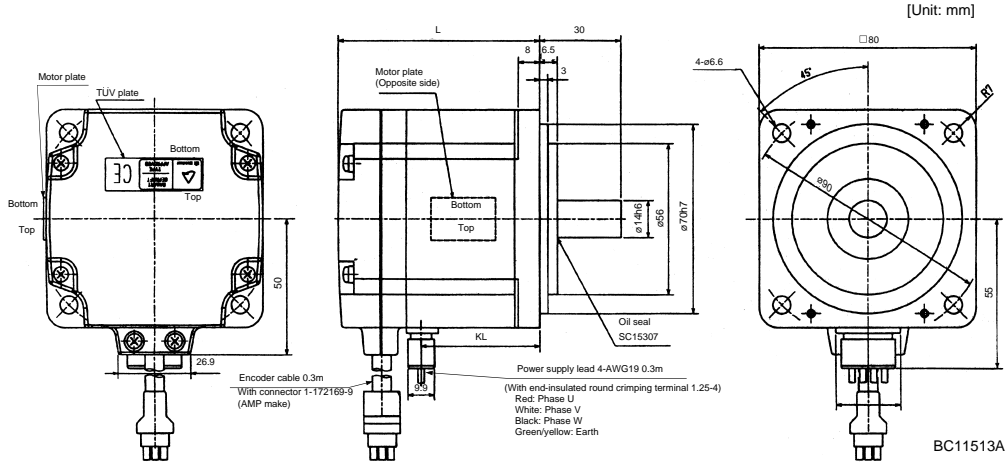
Model	Output (kW)	Inertia Moment $J(\times 10^{-4} \text{kg}\cdot\text{m}^2)$	Weight (kg)
HC-UF13	100	0.66	0.8



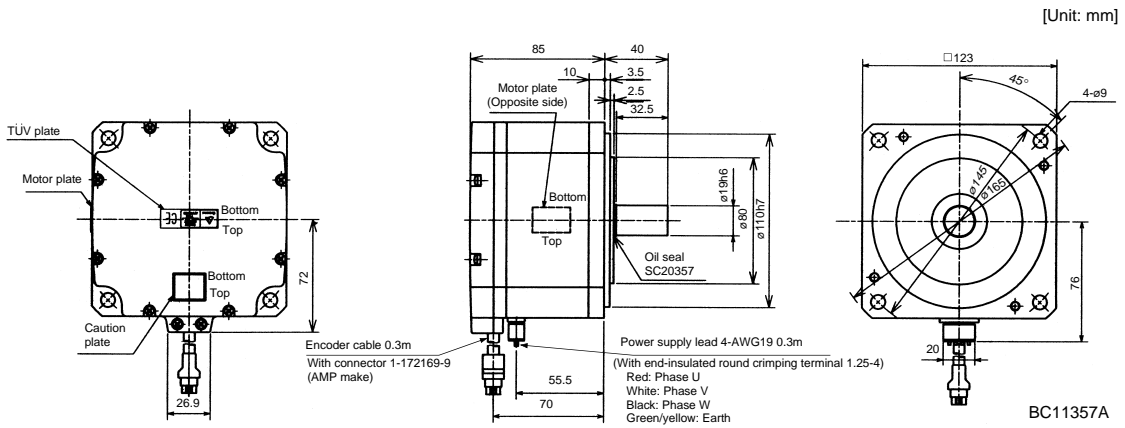
BC11740A

# 10. SPECIFICATIONS

Model	Output (W)	Variable Dimensions		Inertia Moment $J(\times 10^{-4} \text{kg}\cdot\text{m}^2)$	Weight (kg)
		L	KL		
HC-UF23	200	77	43.8	0.241	1.5
HC-UF43	400	92	58.8	0.365	1.7

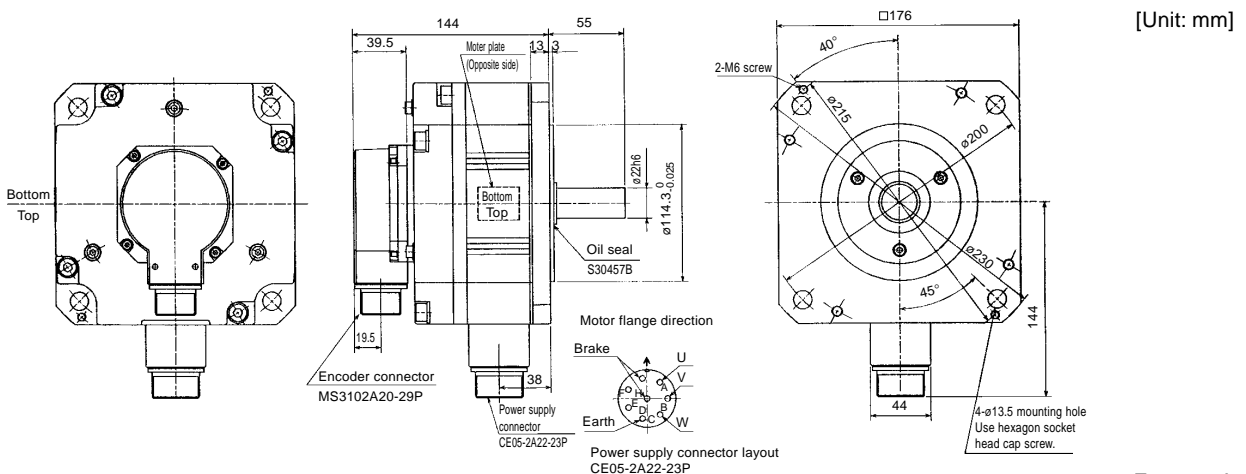


Model	Output (W)	Inertia Moment $J(\times 10^{-4} \text{kg}\cdot\text{m}^2)$	Weight (kg)
HC-UF73	750	5.9	5.0



## 2) With electromagnetic brake

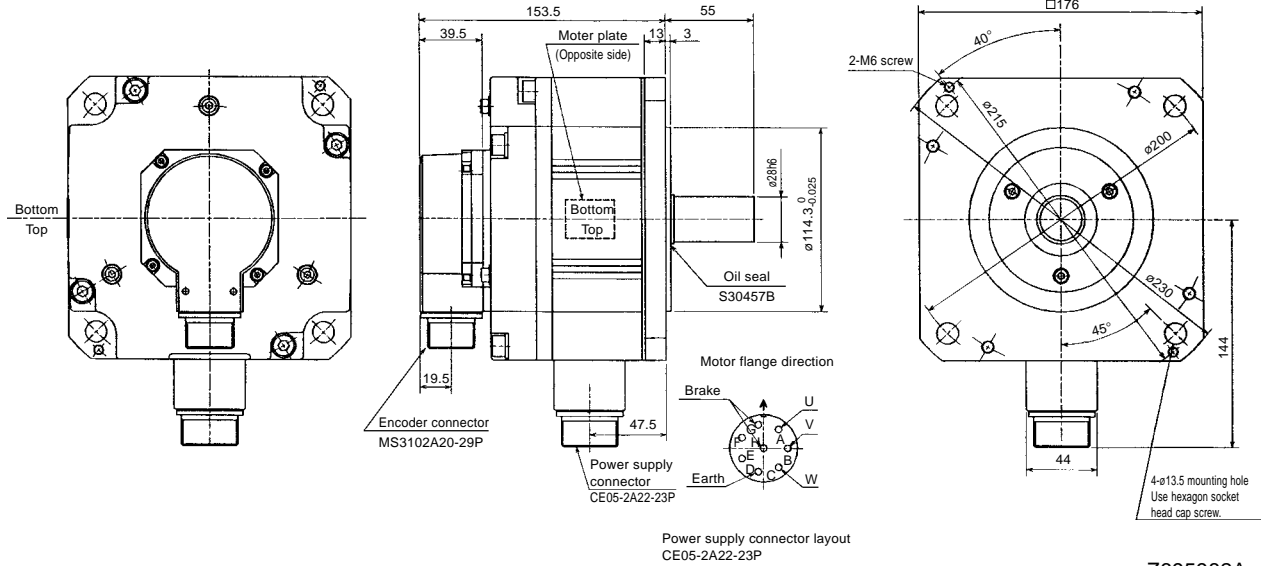
Model	Output (kW)	Braking Force (N·m)	Inertia Moment $J(\times 10^{-4} \text{kg}\cdot\text{m}^2)$	Weight (kg)
HC-UF72B	0.75	8.5	12.4	10



# 10. SPECIFICATIONS

Model	Output (kW)	Braking Force (N·m)	Inertia Moment $J(\times 10^{-4} \text{kg}\cdot\text{m}^2)$	Weight (kg)
HC-UF152B	1.5	8.5	28.9	13

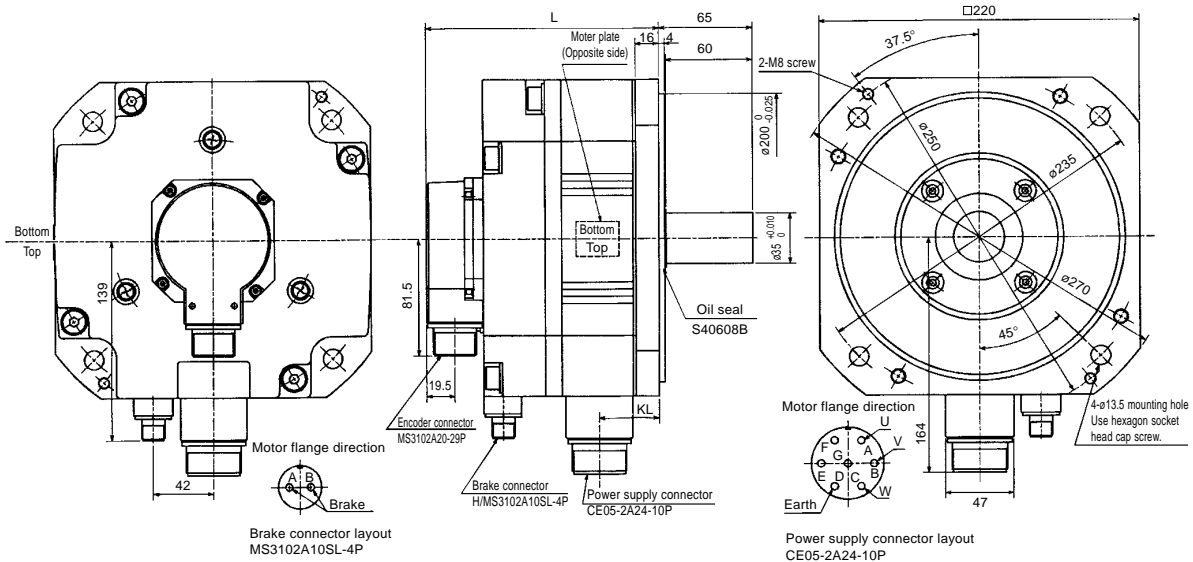
[Unit: mm]



Z695982A

Model	Output (kW)	Variable Dimensions		Braking Force (N·m)	Inertia Moment $J(\times 10^{-4} \text{kg}\cdot\text{m}^2)$	Weight (kg)
		L	KL			
HC-UF202B	2.0	161	42.5	43.1	46.8	22

[Unit: mm]

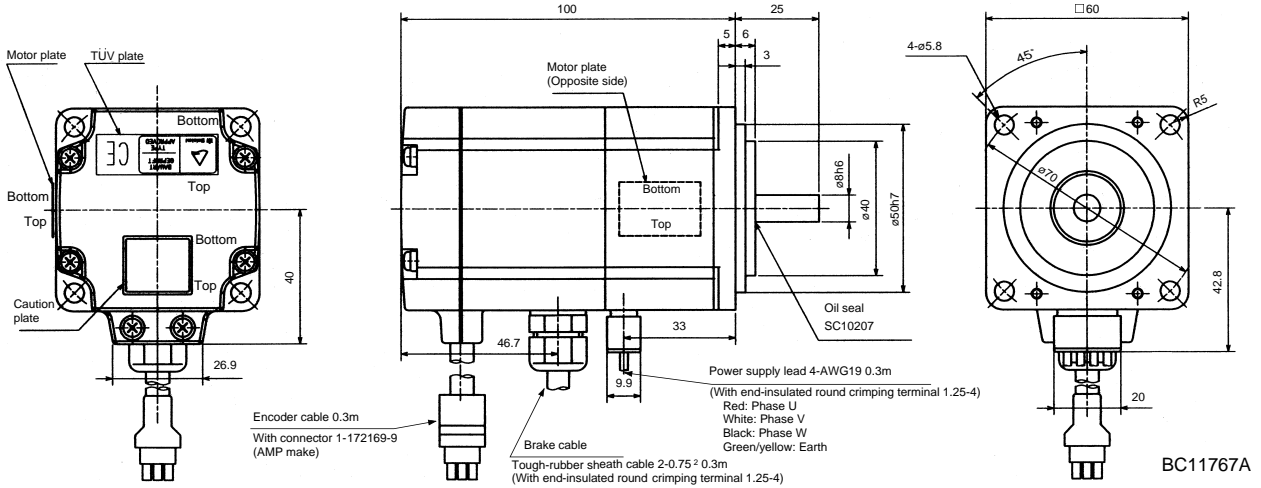


BC10647A

# 10. SPECIFICATIONS

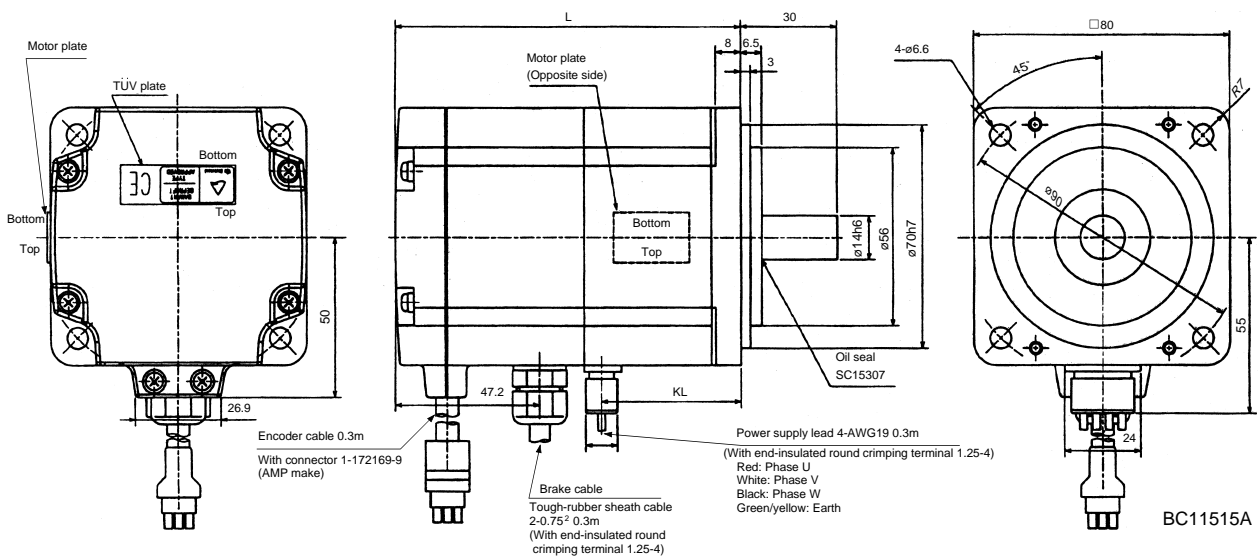
Model	Output (kW)	Braking Force (N-m)	Inertia Moment $J(\times 10^{-4} \text{kg}\cdot\text{m}^2)$	Weight (kg)
HC-UF13B	100	0.32	0.074	1.2

[Unit: mm]



Model	Output (W)	Variable Dimensions		Braking Force (N-m)	Inertia Moment $J(\times 10^{-4} \text{kg}\cdot\text{m}^2)$	Weight (kg)
		L	KL			
HC-UF23B	200	111	43.8	1.3	0.323	2.2
HC-UF43B	400	126	58.8	1.3	0.477	2.4

[Unit: mm]



# 10. SPECIFICATIONS

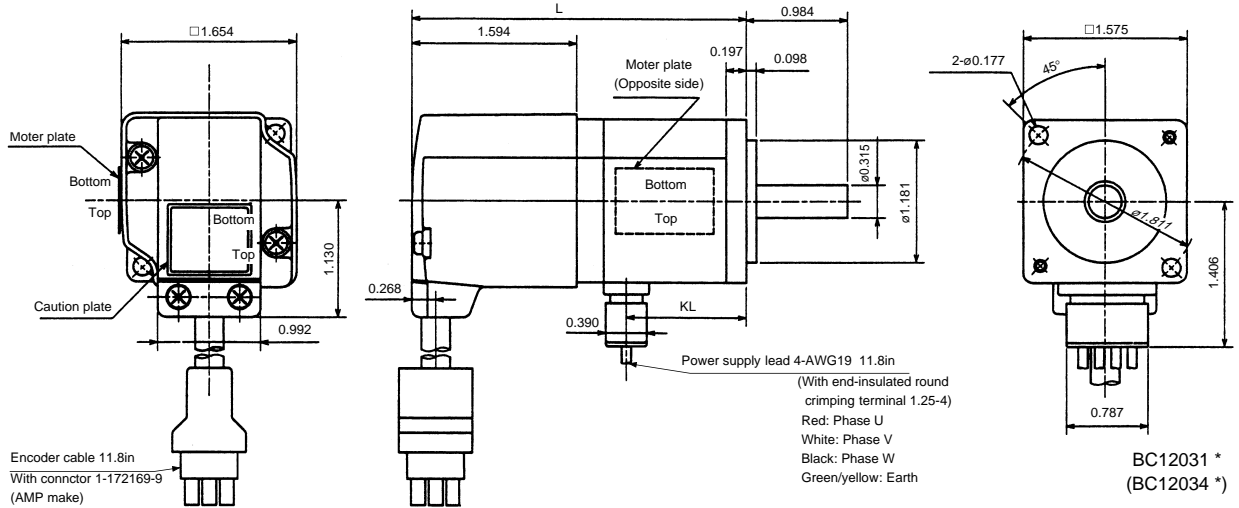
## 10-5-3 Servo motors (in inches)

### (1) HC-MF series

#### 1) Standard (without electromagnetic brake, without reduction gear)

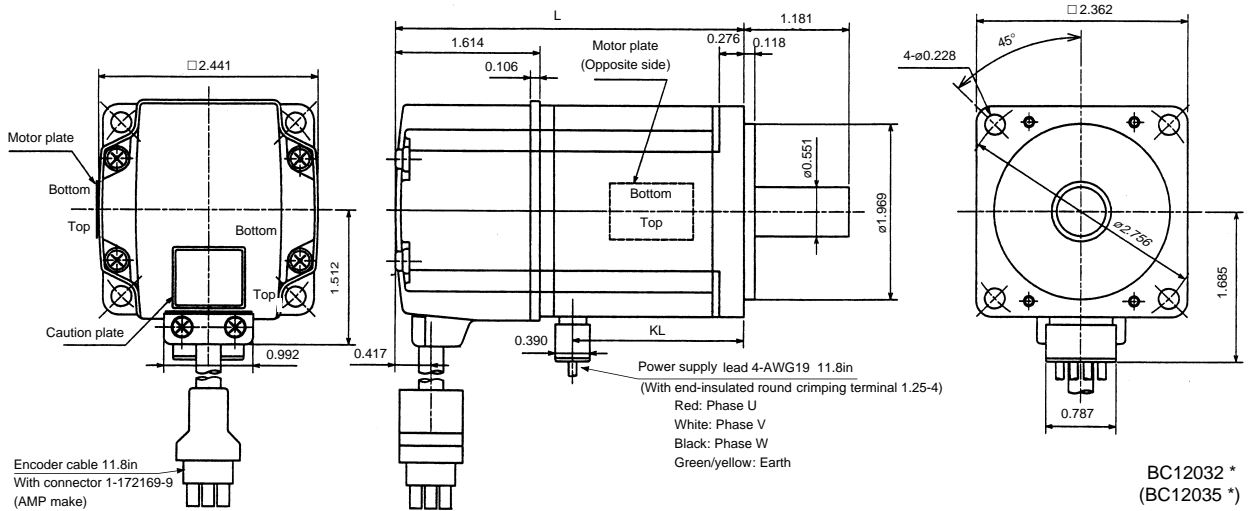
Model	Output (W)	Variable Dimensions (in)		Inertia Moment $WK^2(oz\cdot in^2)$	Weight (lb)
		L	KL		
HC-MF053	50	3.21	1.16	0.10	0.9
HC-MF13	100	3.80	0.18	0.16	1.2

[Unit: in]



Model	Output (W)	Variable Dimensions (in)		Inertia Moment $WK^2(oz\cdot in^2)$	Weight (lb)
		L	KL		
HC-MF23	200	3.92	1.93	0.48	2.2
HC-MF43	400	4.90	0.06	0.78	3.2

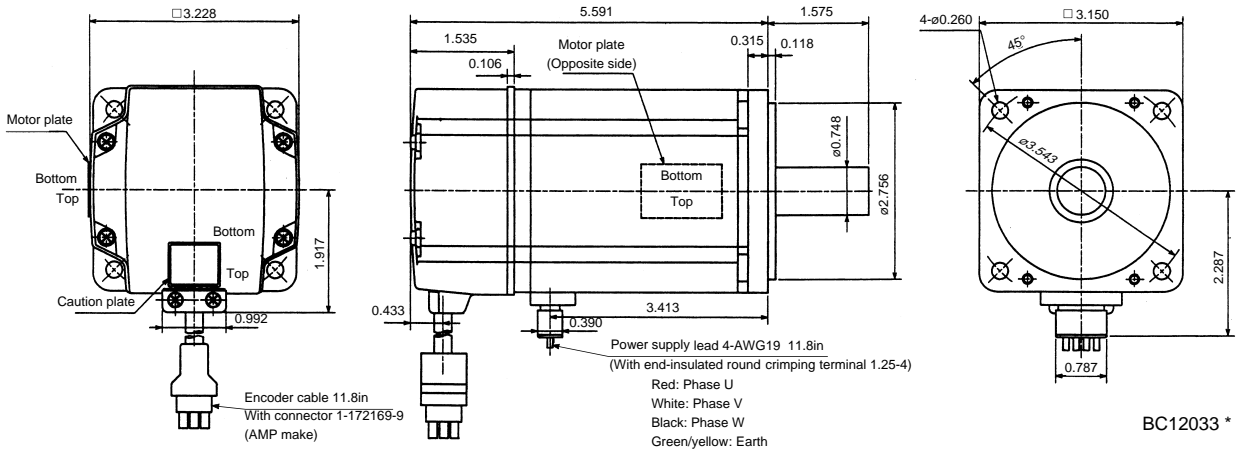
[Unit: in]



# 10. SPECIFICATIONS

Model	Output (W)	Inertia Moment $WK^2(oz\cdot in^2)$	Weight (lb)
HC-MF73	750	3.28	6.6

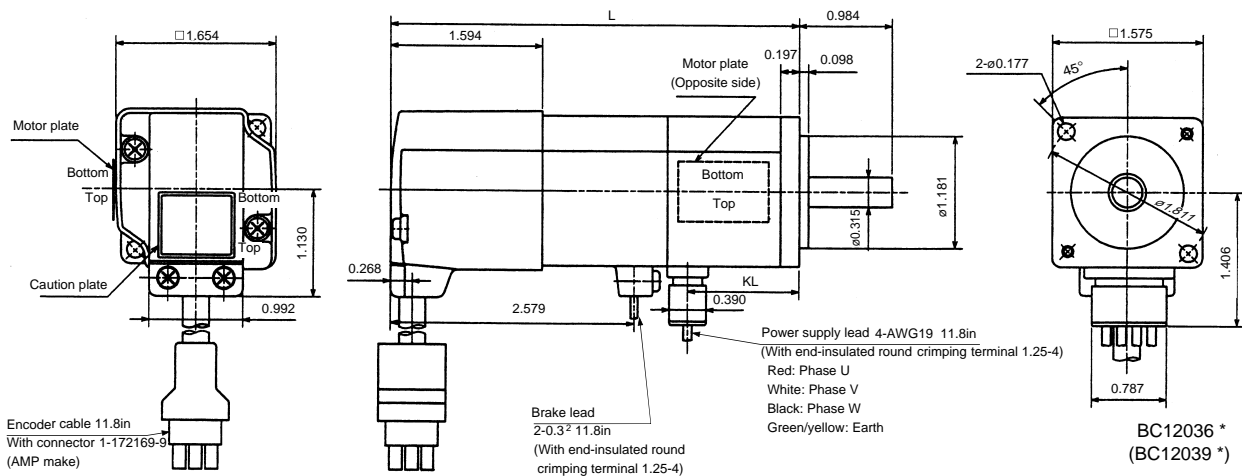
[Unit: in]



## 2) With electromagnetic brake

Model	Output (W)	Variable Dimensions (in)		Braking Force (oz·in)	Inertia Moment $WK^2(oz\cdot in^2)$	Weight (lb)
		L	KL			
HC-MF053B	50	4.31	1.16	45.32	0.12	1.7
HC-MF13B	100	4.90	1.75	45.32	0.18	2.0

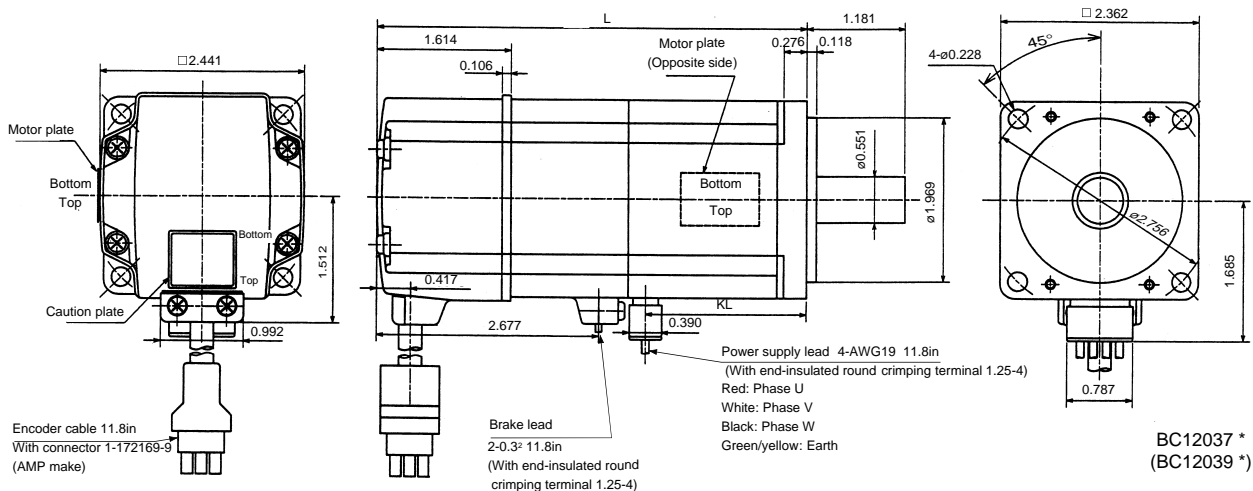
[Unit: in]



# 10. SPECIFICATIONS

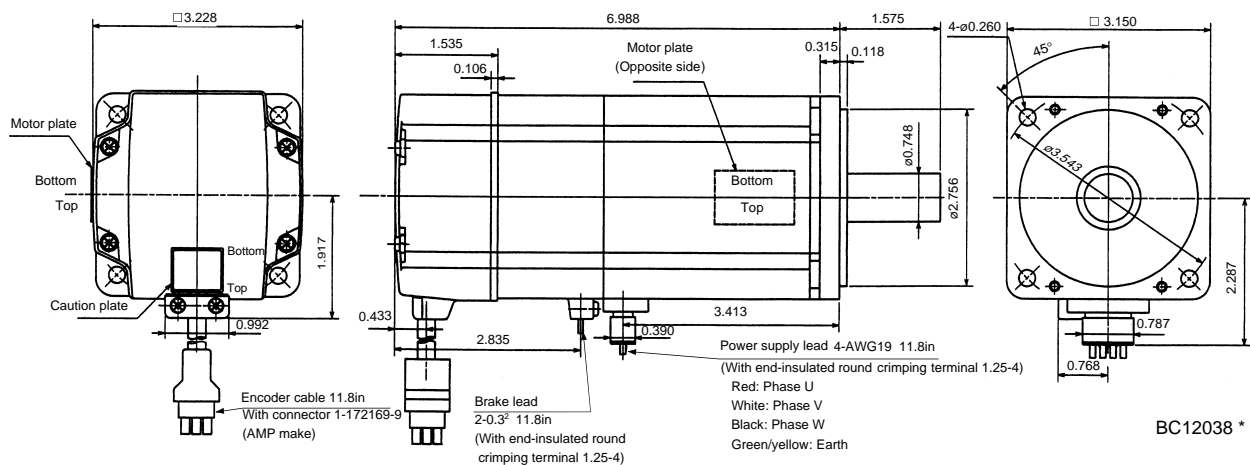
Model	Output (W)	Variable Dimensions (in)		Braking Force (oz•in)	Inertia Moment $WK^2$ (oz•in <sup>2</sup> )	Weight (lb)
		L	KL			
HC-MF23B	200	5.18	1.03	184	0.74	3.5
HC-MF43B	400	6.16	2.84	184	1.04	4.6

[Unit: in]



Model	Output (W)	Braking Force (oz•in)	Inertia Moment $WK^2$ (oz•in <sup>2</sup> )	Weight (lb)
HC-MF73B	750	340	3.96	8.8

[Unit: in]

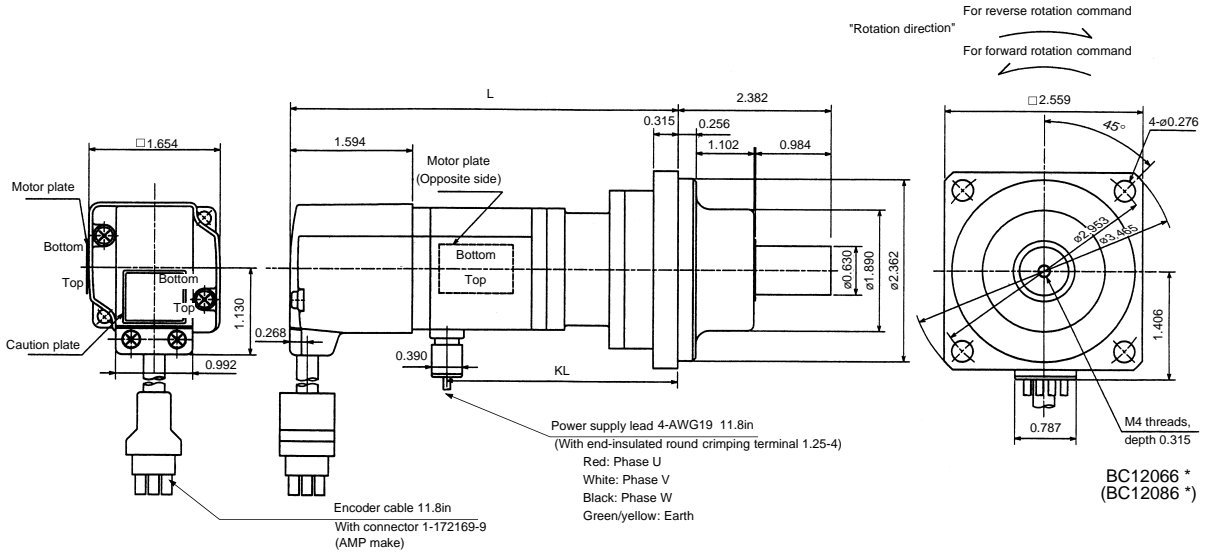


# 10. SPECIFICATIONS

- 3) With reduction gear for general industrial machine
  - a) Without electromagnetic brake

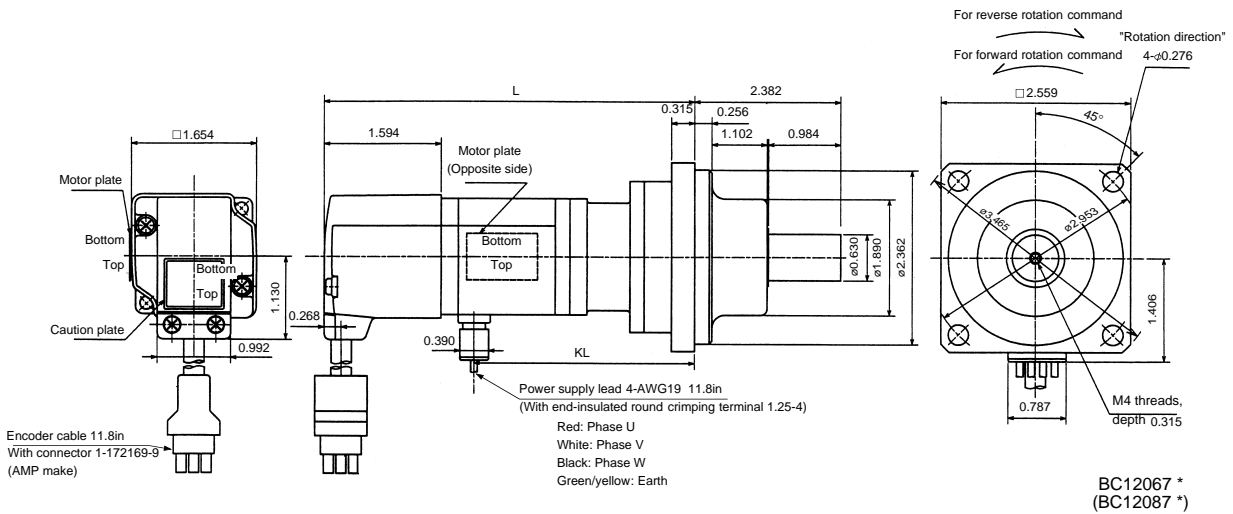
Model	Output (W)	Variable Dimensions (in)		Reduction Gear Model	Reduction Ratio (Actual Reduction Ratio)	Inertia Moment $WK^2(oz\cdot in^2)$	Backlash	Weight (lb)
		L	KL					
HC-MF053G1	50	4.96	2.91	K6505	1/5(9/44)	0.30	60min. max.	3.1
HC-MF053G1	50	5.669	3.62	K6512	1/12(49/576)	0.42	60min. max.	4.0
HC-MF053G1	50	5.669	3.62	K6520	1/20(25/484)	0.32	60min. max.	4.0

[Unit: in]



Model	Output (W)	Variable Dimensions (in)		Reduction Gear Model	Reduction Ratio (Actual Reduction Ratio)	Inertia Moment $WK^2(oz\cdot in^2)$	Backlash	Weight (lb)
		L	KL					
HC-MF13G1	100	5.551	3.5	K6505	1/5(9/44)	0.36	60min. max.	3.3
HC-MF13G1	100	6.26	4.21	K6512	1/12(49/576)	0.48	60min. max.	4.2
HC-MF13G1	100	6.26	4.21	K6520	1/20(25/484)	0.38	60min. max.	4.2

[Unit: in]

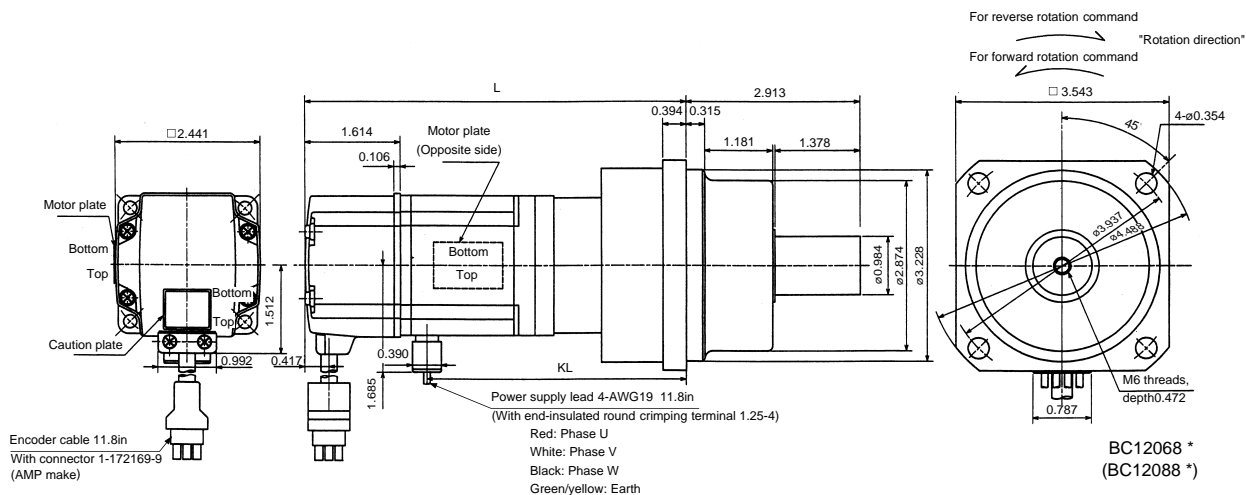




# 10. SPECIFICATIONS

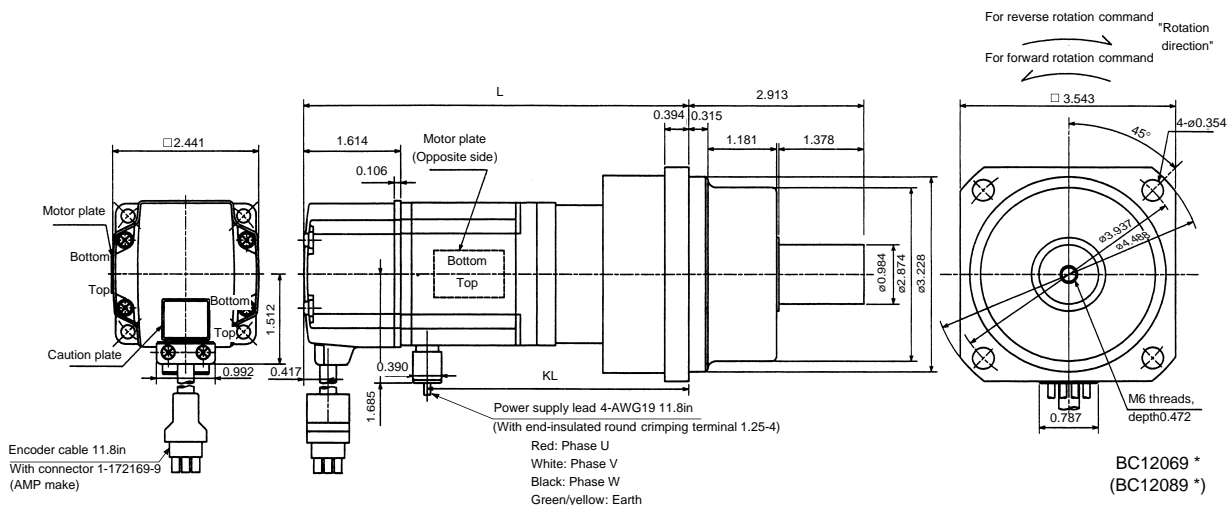
Model	Output (W)	Variable Dimensions (in)		Reduction Gear Model	Reduction Ratio (Actual Reduction Ratio)	Inertia Moment $WK^2$ (oz·in <sup>2</sup> )	Weight (lb)
		L	KL				
HC-MF23G1	200	6.02	4.04	K9005	1/5(19/96)	1.36	7.3
HC-MF23G1	200	6.81	4.83	K9012	1/12(25/288)	1.60	8.6
HC-MF23G1	200	6.81	4.83	K9020	1/20(253/5000)	1.45	8.6

[Unit: in]



Model	Output (W)	Variable Dimensions (lb)		Reduction Gear Model	Reduction Ratio (Actual Reduction Ratio)	Inertia Moment $WK^2$ (oz·in <sup>2</sup> )	Weight (lb)
		L	KL				
HC-MF43G1	400	7.01	4.95	K9005	1/5(19/96)	1.62	8.4
HC-MF43G1	400	7.80	5.73	K9012	1/12(25/288)	1.85	9.7

[Unit: in]

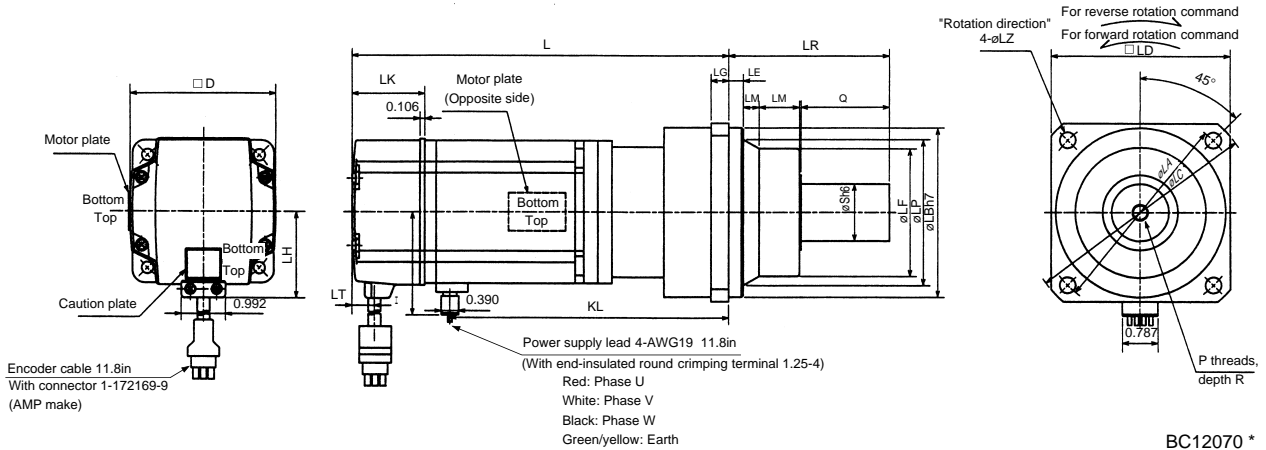


# 10. SPECIFICATIONS

Model	Output (W)	Reduction Gear Model	Reduction Ratio		Inertia Moment WK <sup>2</sup> (oz•in <sup>2</sup> )	Backlash	Weight (lb)
			Normal Reduction ratio	Actual Reduction ratio			
HC-MF43G1	400	K10020	1/20	253/5000	3.57	60min. max.	12.13
HC-MF73G1	750	K10005	1/5	1/5	5.58	60min. max.	13.67
HC-MF73G1	750	K10012	1/12	525/6048	9.22	60min. max.	16.09
HC-MF73G1	750	K12020	1/20	625/12544	9.57	60min. max.	22.27

Model	Output (W)	Variable Dimensions (in)																	(Reduction Ratio)														
		D	L	H	K	L	T	H	L	A	B	L	C	L	D	E	L	F		L	G	L	M	N	L	P	L	L	R	K	L	Z	Q
HC-MF43G1	400	2.362	1.50	1.61	0.42	1.69	4.53	3.74	5.20	3.94	0.39	2.87	0.39	0.512	0.63	3.39	7.933	3.54	5.87	0.35	1.97	1.26	M8	0.63	1/20								
HC-MF73G1	750	3.15	1.89	1.54	0.43	2.29	4.53	3.74	5.20	3.94	0.39	2.87	0.39	0.512	0.63	3.39	8.15	3.54	5.97	0.35	1.97	1.26	M8	0.63	1/5								
HC-MF73G1	750	3.15	1.89	1.54	0.43	2.29	4.53	3.74	5.20	3.94	0.39	2.87	0.39	0.512	0.63	3.39	9.016	3.54	6.84	0.35	1.97	1.26	M8	0.63	1/12								
HC-MF73G1	750	3.15	1.89	1.54	0.43	2.29	5.51	4.53	6.38	4.72	0.47	3.54	0.59	0.512	0.787	4.09	9.528	4.17	7.35	0.35	2.36	1.57	M10	0.79	1/20								

[Unit: in]

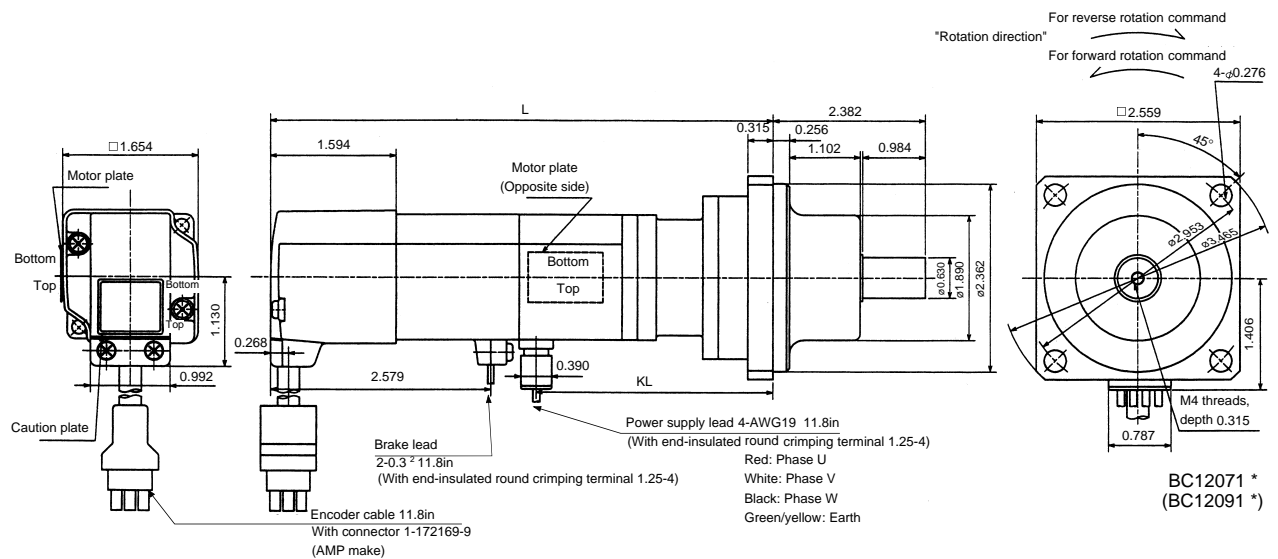


# 10. SPECIFICATIONS

b) With electromagnetic brake

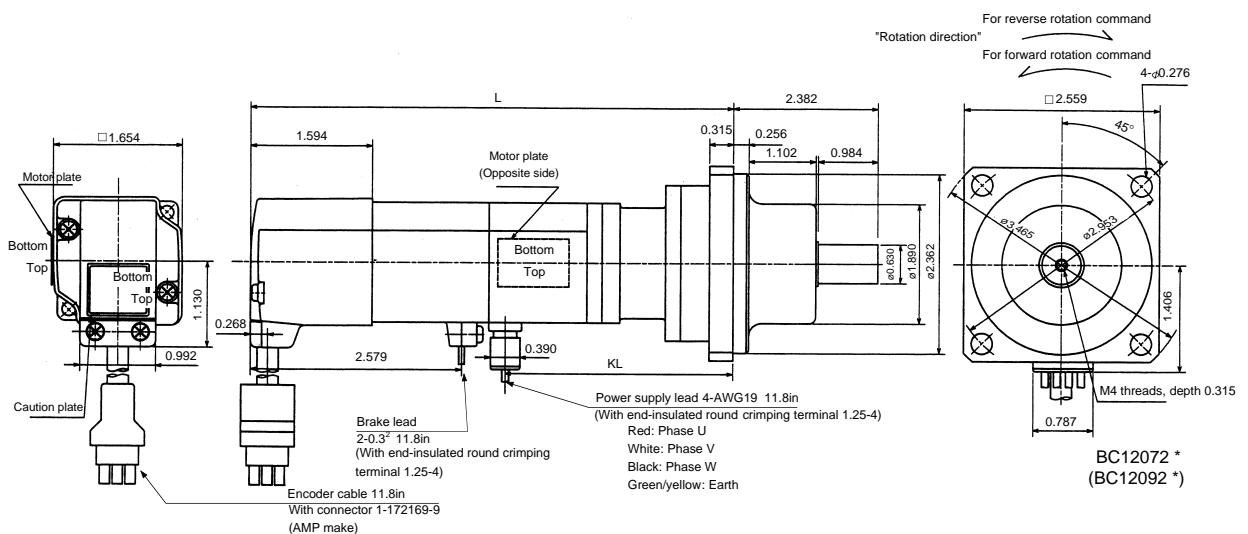
Model	Output (W)	Variable Dimensions (in)		Braking Force (oz·in)	Reduction Gear Model	Reduction Ratio	Inertia Moment WK <sup>2</sup> (oz·in <sup>2</sup> )	Backlash	Weight (lb)
		L	KL						
HC-MF053BG1	50	6.06	2.91	45	K6505	1/5(9/44)	0.32	60min. max.	4.0
HC-MF053BG1	50	6.77	3.62	45	K6512	1/12(49/576)	0.44	60min. max.	4.9
HC-MF053BG1	50	6.77	3.62	45	K6520	1/20(25/484)	0.34	60min. max.	4.9

[Unit: in]



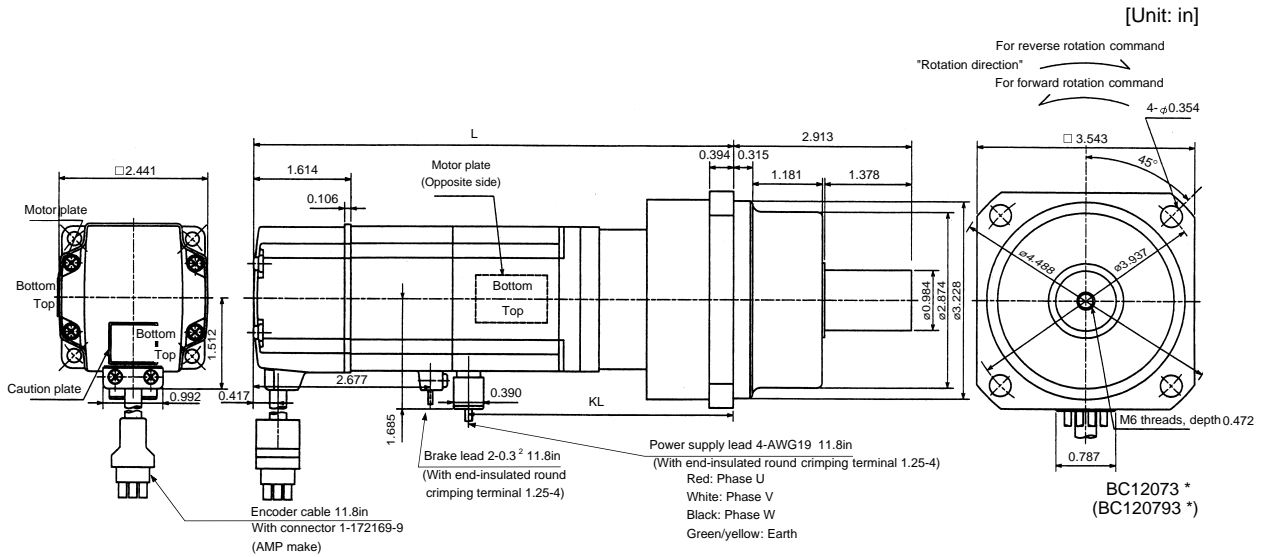
Model	Output (W)	Variable Dimensions (in)		Braking Force (oz·in)	Reduction Gear Model	Reduction Ratio	Inertia Moment WK <sup>2</sup> (oz·in <sup>2</sup> )	Backlash	Weight (lb)
		L	KL						
HC-MF13BG1	100	6.65	3.43	45	K6505	1/5(9/44)	0.38	60min. max.	4.2
HC-MF13BG1	100	7.36	4.21	45	K6512	1/12(49/576)	0.50	60min. max.	5.1
HC-MF13BG1	100	7.36	4.21	45	K6520	1/20(25/484)	0.40	60min. max.	5.1

[Unit: in]

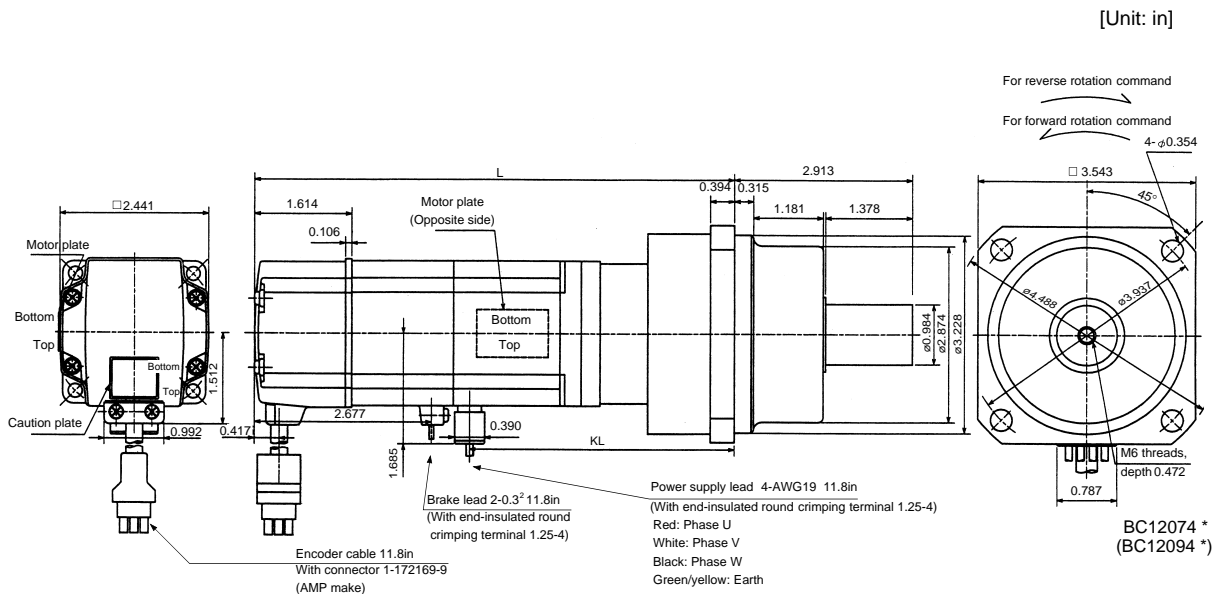


# 10. SPECIFICATIONS

Model	Output (W)	Variable Dimensions (in)		Reduction Gear Model	Reduction Ratio (Actual Reduction Ratio)	Inertia Moment $WK^2(oz\cdot in^2)$	Weight (lb)
		L	KL				
HC-MF23BG1	200	6.65	4.04	K9005	1/5(19/96)	1.58	8.6
HC-MF23BG1	200	7.36	4.23	K9012	1/12(25/288)	1.82	9.9
HC-MF23BG1	200	7.36	4.23	K9020	1/20(253/5000)	1.67	9.9



Model	Output (W)	Variable Dimensions (in)		Braking Force (oz·in)	Reduction Gear Model	Reduction Ratio (Actual Reduction Ratio)	Inertia Moment $WK^2(oz\cdot in^2)$	Weight (lb)
		L	KL					
HC-MF43BG1	400	8.27	4.95	184	K9005	1/5(19/96)	1.88	9.7
HC-MF43BG1	400	9.06	5.73	184	K9012	1/12(25/288)	2.12	11.0

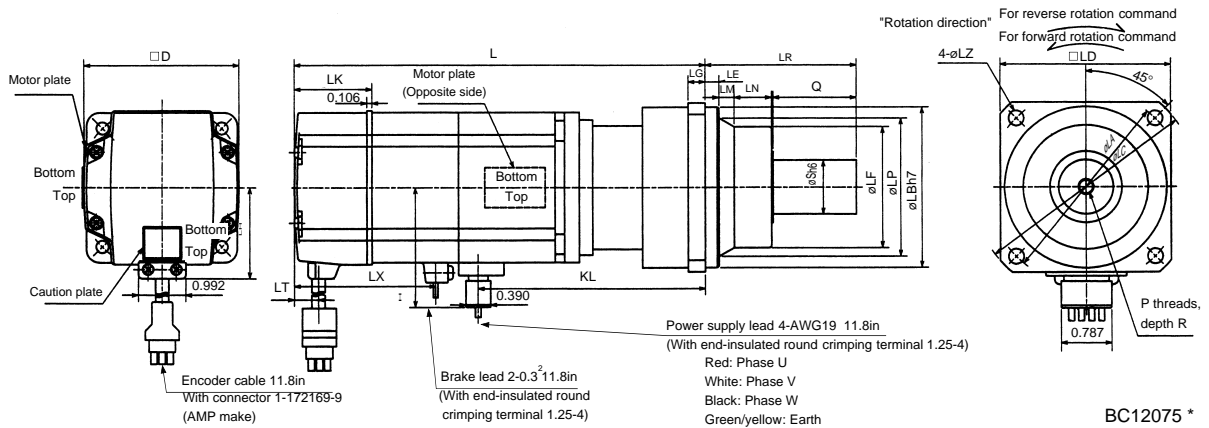


# 10. SPECIFICATIONS

Model	Output (W)	Brake Force (oz•in)	Reduction Gear Model	Reduction Ratio		Inertia Moment WK <sup>2</sup> (oz•in <sup>2</sup> )	Backlash	Weight (lb)
				Normal Reduction ratio	Actual Reduction ratio			
HC-MF43BG1	400	184	K10020	1/20	253/5000	3.83	60min. max.	13.4
HC-MF73BG1	750	340	K10005	1/5	1/5	6.26	60min. max.	15.9
HC-MF73BG1	750	340	K10012	1/12	525/6048	9.90	60min. max.	18.3
HC-MF73BG1	750	340	K12020	1/20	625/12544	10.25	60min. max.	25.8

Model	Output (W)	Variable Dimensions (in)																(Reduction Ratio)								
		D	LH	LK	LT	LX	H	LA	LB	LC	LD	LE	LF	LG	LM	LN	LP		L	LR	KL	LZ	Q	S	P	R
HC-MF43BG1	400	2.44	1.51	1.64	0.14	2.68	1.69	4.53	3.74	5.20	3.94	0.39	2.87	0.39	0.512	0.63	3.39	9.19	3.54	5.87	0.35	1.97	1.26	M8	0.63	1/20
HC-MF73BG1	750	3.23	1.92	1.54	0.43	2.84	1.69	4.53	3.74	5.20	3.94	0.39	2.87	0.39	0.512	0.63	3.39	9.55	3.54	5.92	0.35	1.97	1.26	M8	0.63	1/5
HC-MF73BG1	750	3.23	1.92	1.54	0.43	2.84	1.69	4.53	3.74	5.20	3.94	0.39	2.87	0.39	0.512	0.63	3.39	10.41	3.54	6.84	0.35	1.97	1.26	M8	0.63	1/12
HC-MF73BG1	750	3.23	1.92	1.54	0.43	2.84	1.69	5.51	4.53	6.38	4.72	0.47	3.54	0.39	0.512	0.787	4.09	10.93	4.17	7.35	0.55	2.36	1.57	M10	0.79	1/20

[Unit: in]

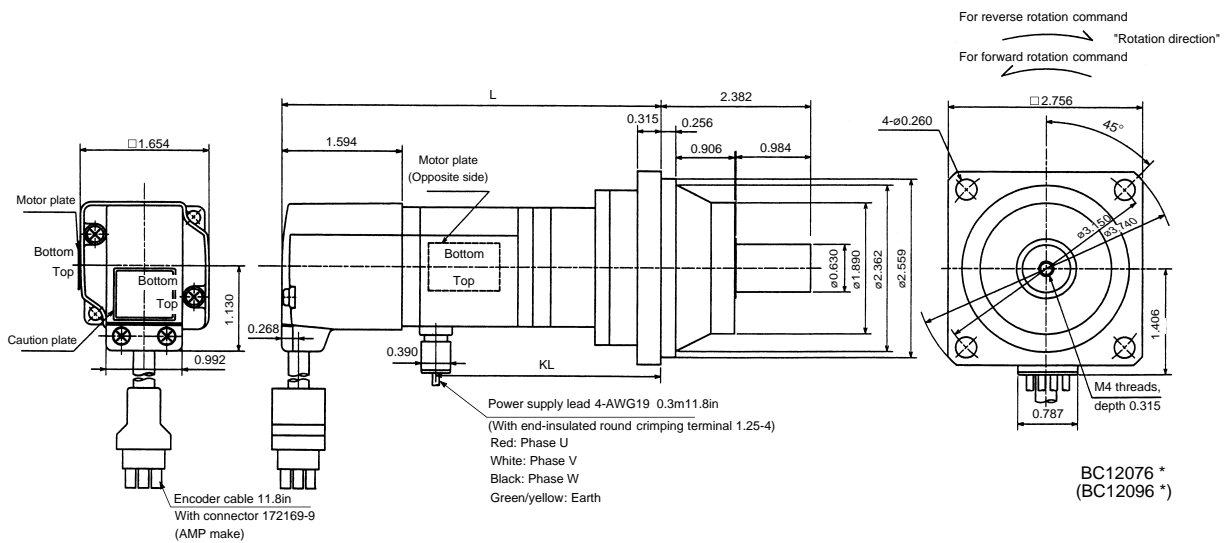


# 10. SPECIFICATIONS

- 4) With reduction gear for precision application
  - a) Without electromagnetic brake

Model	Output (W)	Variable Dimensions (in)		Reduction Gear Model	Reduction Ratio	Inertia Moment WK <sup>2</sup> (oz•in <sup>2</sup> )	Backlash	Weight (lb)
		L	KL					
HC-MF053G2	50	5.12	3.07	BK1-05B-A5MEKA	1/5	0.36	3 min. max.	3.1
HC-MF053G2	50	5.75	3.70	BK1-09B-A5MEKA	1/9	0.33	3 min. max.	3.7
HC-MF053G2	50	5.75	3.70	BK1-20B-A5MEKA	1/20	0.38	3 min. max.	4.0
HC-MF053G2	50	5.75	3.70	BK1-29B-A5MEKA	1/29	0.31	3 min. max.	4.0

[Unit: in]

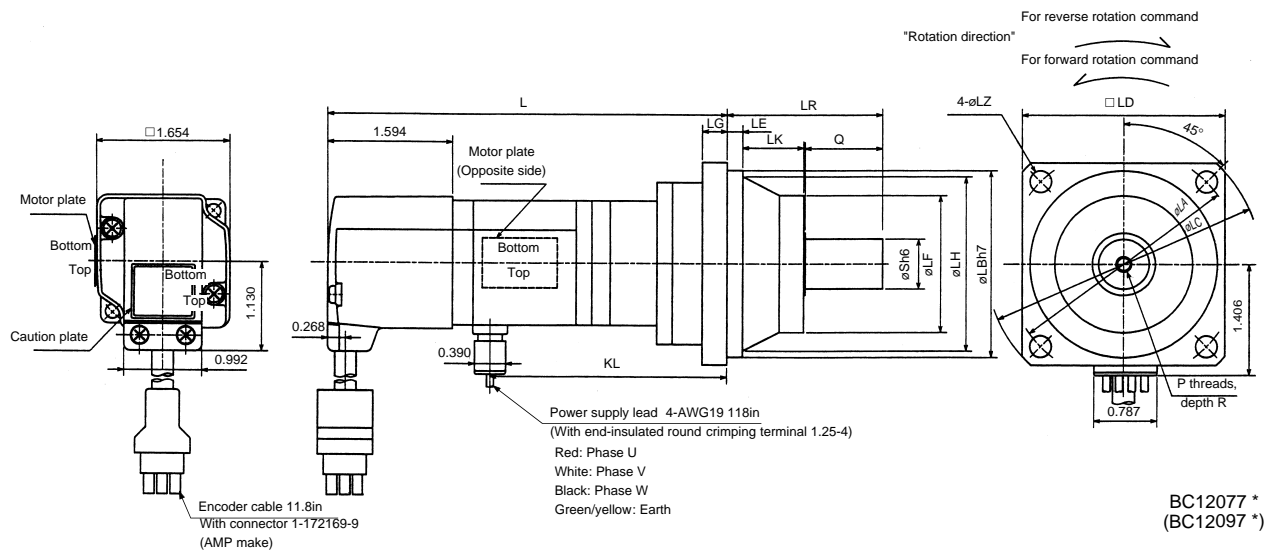


# 10. SPECIFICATIONS

Model	Output (W)	Reduction Gear Model	Reduction Ratio	Inertia Moment $WK^2$ (oz·in <sup>2</sup> )	Backlash	Weight (lb)
HC-MF13G2	100	BK1-05B-01MEKA	1/5	0.43	3 min. max.	3.3
HC-MF13G2	100	BK1-09B-01MEKA	1/9	0.39	3 min. max.	4.0
HC-MF13G2	100	BK2-20B-01MEKA	1/20	0.66	3 min. max.	6.6
HC-MF13G2	100	BK2-29B-01MEKA	1/29	0.52	3 min. max.	6.6

Model	Output (W)	Variable Dimensions (in)																	(Reduction Ratio)
		LA	LB	LC	LD	LE	LF	LG	LH	LK	L	LR	KL	LZ	Q	S	P	R	
HC-MF13G2	100	3.15	2.56	3.74	2.76	0.24	1.89	0.31	2.362	0.906	5.71	2.17	3.66	0.26	0.98	0.63	M4	0.31	1/5
HC-MF13G2	100	3.15	2.56	3.74	2.76	0.24	1.89	0.31	2.362	0.906	6.34	2.17	4.29	0.26	0.98	0.63	M4	0.31	1/9
HC-MF13G2	100	3.94	3.15	4.53	3.35	0.24	2.559	0.39	2.913	2.913	6.57	2.95	4.53	0.26	1.38	0.79	M5	0.39	1/20
HC-MF13G2	100	3.94	3.15	4.53	3.35	0.24	2.559	0.39	2.913	2.913	6.57	2.95	4.53	0.26	1.38	0.79	M5	0.39	1/29

[Unit: in]

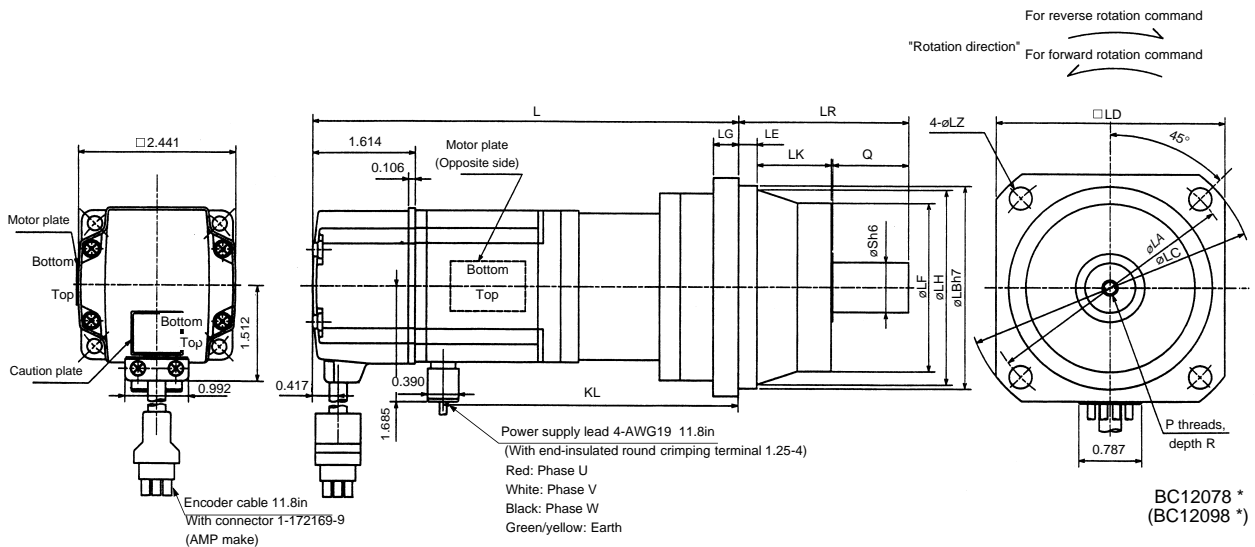


# 10. SPECIFICATIONS

Model	Output (W)	Reduction Gear Model	Reduction Ratio	Inertia Moment $WK^2(\text{oz}\cdot\text{in}^2)$	Weight (lb)
HC-MF23G2	200	BK1-05B-02MEKA	1/5	1.04	4.6
HC-MF23G2	200	BK2-09B-02MEKA	1/9	1.14	7.7
HC-MF23G2	200	BK3-20B-02MEKA	1/20	1.95	11.0
HC-MF23G2	200	BK3-29B-02MEKA	1/29	1.51	11.0

Model	Output (W)	Variable Dimensions (in)																	(Reduction Ratio)
		LA	LB	LC	LD	LE	LF	LG	LH	LK	L	LR	KL	LZ	Q	S	P	R	
HC-MF23G2	200	3.15	2.56	3.74	2.76	0.24	1.89	0.31	2.362	0.906	6.18	2.17	4.20	0.26	0.98	0.63	M4	0.31	1/5
HC-MF23G2	200	3.94	3.15	4.53	3.35	0.24	2.559	0.39	2.913	1.299	6.89	2.95	4.91	0.26	1.38	0.79	M5	0.39	1/9
HC-MF23G2	200	4.53	3.74	5.31	3.94	0.31	2.953	0.39	3.346	1.378	7.09	3.35	5.10	0.35	1.57	0.98	M6	0.47	1/20
HC-MF23G2	200	4.53	3.74	5.31	3.94	0.31	2.953	0.39	3.346	1.378	7.09	3.35	5.10	0.35	1.57	0.98	M6	0.47	1/29

[Unit: in]

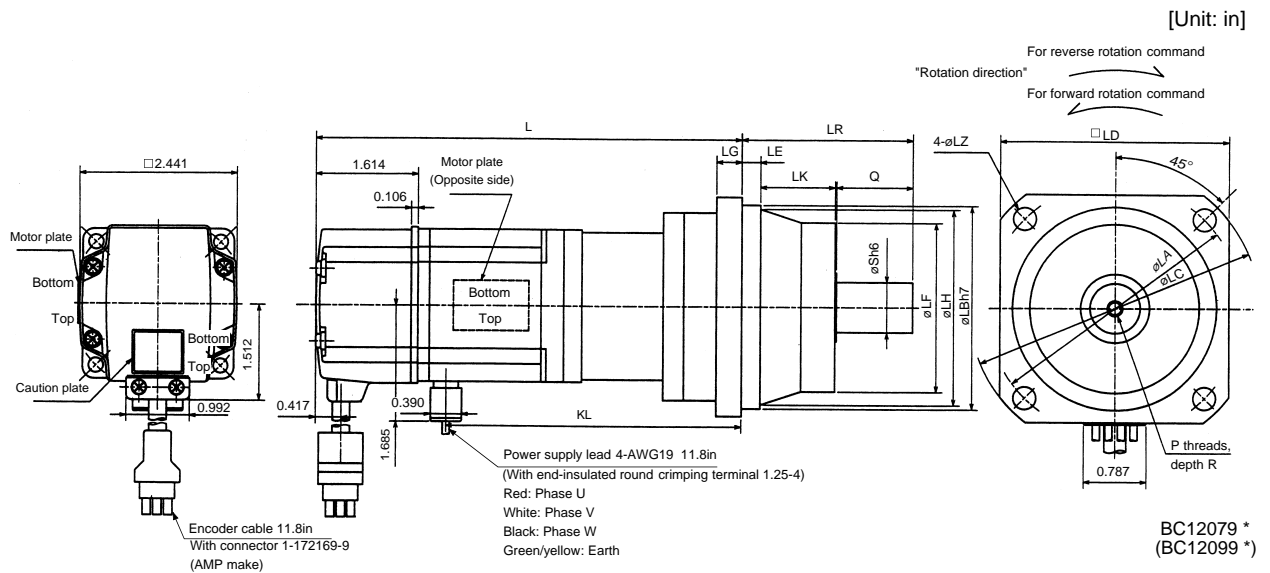




# 10. SPECIFICATIONS

Model	Output (W)	Reduction Gear Model	Reduction Ratio	Inertia Moment $WK^2$ (oz·in <sup>2</sup> )	Weight (lb)
HC-MF43G2	400	BK2-05B-04MEKA	1/5	1.61	8.2
HC-MF43G2	400	BK3-09B-04MEKA	1/9	1.77	11.7
HC-MF43G2	400	BK4-20B-04MEKA	1/20	2.33	16.5
HC-MF43G2	400	BK4-29B-04MEKA	1/29	1.85	16.5

Model	Output (W)	Variable Dimensions (in)																	(Reduction Ratio)
		LA	LB	LC	LD	LE	LF	LG	LH	LK	L	LR	KL	LZ	Q	S	P	R	
HC-MF43G2	400	3.94	3.15	4.53	3.35	0.24	2.56	0.39	2.91	1.3	7.24	2.95	5.18	0.26	1.38	0.79	M5	0.39	1/5
HC-MF43G2	400	4.53	3.74	5.32	3.94	0.31	2.95	0.39	3.35	1.38	8.07	3.35	6.01	0.35	1.58	0.98	M6	0.47	1/9
HC-MF43G2	400	5.32	3.94	6.10	4.53	0.31	3.54	0.47	3.94	1.58	8.31	3.94	6.24	0.43	1.97	1.26	M8	0.63	1/20
HC-MF43G2	400	5.32	4.33	6.10	4.53	0.31	3.54	0.47	3.94	1.58	8.31	3.94	6.24	0.43	1.97	1.26	M8	0.63	1/29

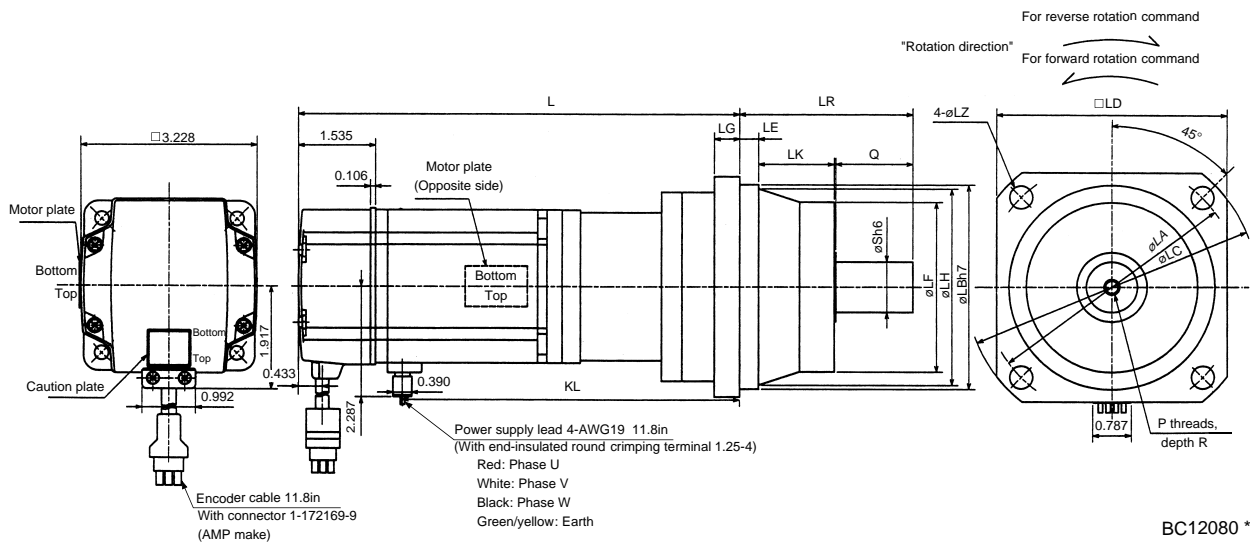


# 10. SPECIFICATIONS

Model	Output (W)	Reduction Gear Model	Reduction Ratio	Inertia Moment $WK^2(\text{oz}\cdot\text{in}^2)$	Weight (lb)
HC-MF73G2	750	BK3-05B-08MEKA	1/5	5.32	13.89
HC-MF73G2	750	BK4-09B-08MEKA	1/9	5.36	18.96
HC-MF73G2	750	BK5-20B-08MEKA	1/20	5.55	26.46
HC-MF73G2	750	BK5-29B-08MEKA	1/29	4.97	26.46

Model	Output (W)	Variable Dimensions (in)																	(Reduction Ratio)
		LA	LB	LC	LD	LE	LF	LG	LH	LK	L	LR	KL	LZ	Q	S	P	R	
HC-MF73G2	750	4.53	3.74	5.31	3.94	0.31	2.953	0.39	3.346	1.378	8.35	3.35	6.17	0.35	1.57	0.98	M6	0.47	1/5
HC-MF73G2	750	5.31	4.33	6.10	4.53	0.31	3.543	0.47	3.937	1.575	9.76	3.94	7.59	0.43	1.97	1.26	M8	0.63	1/9
HC-MF73G2	750	5.91	4.92	6.89	5.12	0.39	4.134	0.59	4.528	1.693	9.76	4.53	7.59	0.55	2.36	1.57	M10	0.79	1/20
HC-MF73G2	750	5.91	4.92	6.89	5.12	0.39	4.134	0.59	4.528	1.693	9.76	4.53	7.59	0.55	2.36	1.57	M10	0.79	1/29

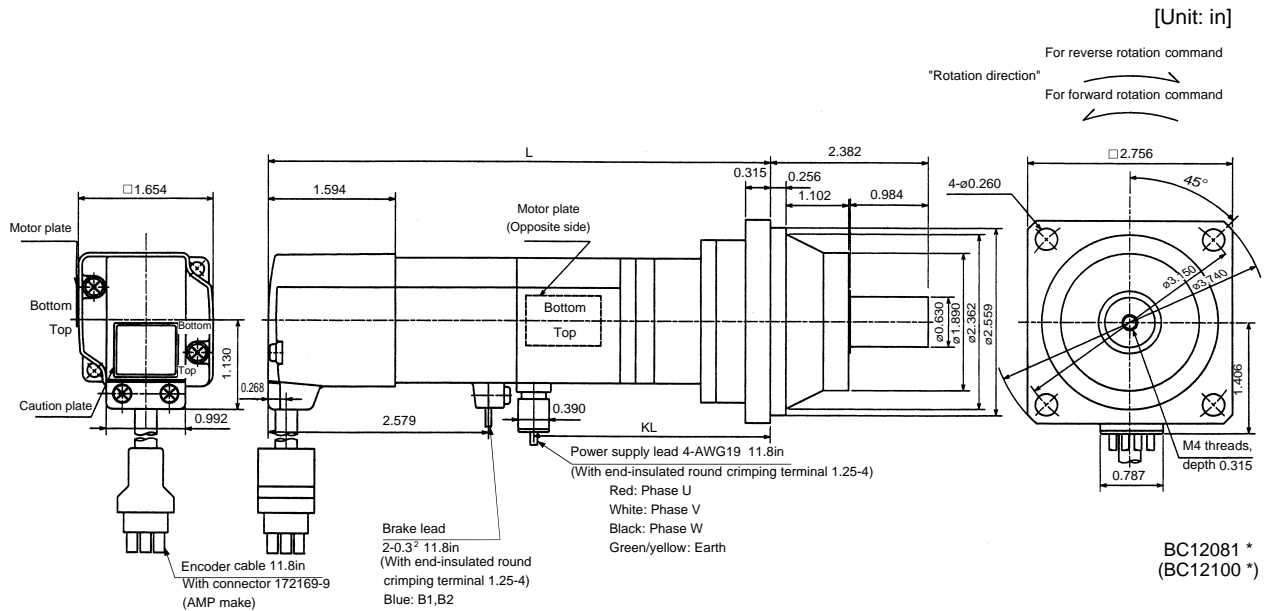
[Unit: in]



# 10. SPECIFICATIONS

b) With electromagnetic brake

Model	Output (W)	Variable Dimensions (in)		Braking Force (oz•m)	Reduction Gear Model	Reduction Ratio	Inertia Moment $WK^2$ (oz•in <sup>2</sup> )	Backlash	Weight (lb)
		L	KL						
HC-MF053BG2	50	6.22	3.07	45	BK1-05B-A5MEKA	1/5	0.38	3 min. max.	4.0
HC-MF053BG2	50	6.85	3.70	45	BK1-09B-A5MEKA	1/9	0.34	3 min. max.	4.6
HC-MF053BG2	50	6.85	3.70	45	BK1-20B-A5MEKA	1/20	0.39	3 min. max.	4.9
HC-MF053BG2	50	6.85	3.70	45	BK1-29B-A5MEKA	1/20	0.33	3 min. max.	4.9

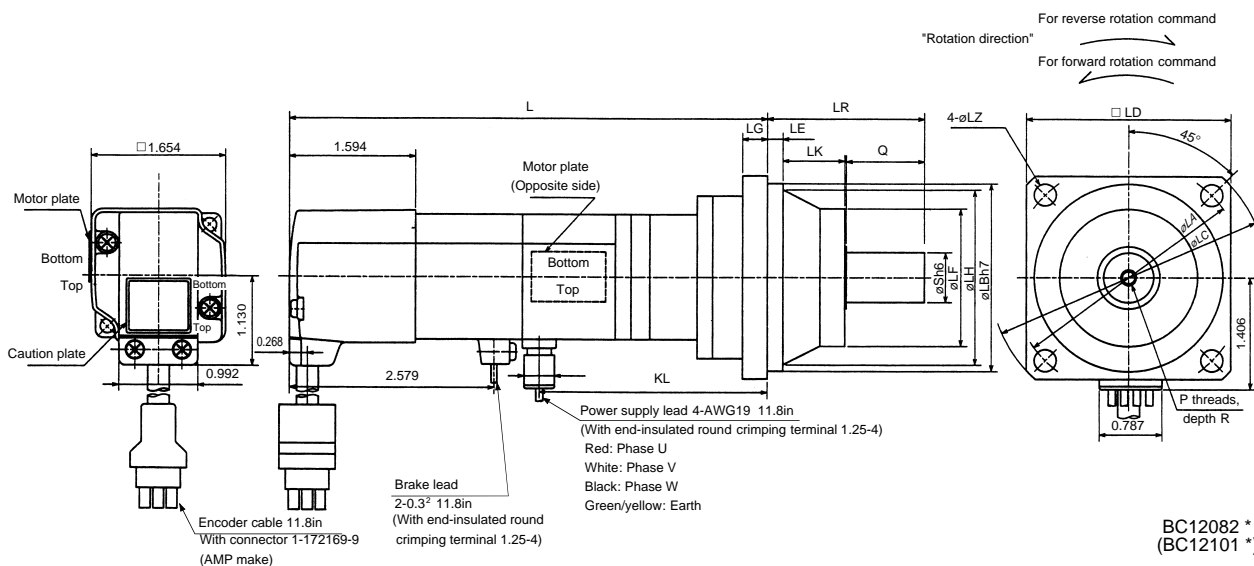


# 10. SPECIFICATIONS

Model	Output (W)	Braking Force (oz•in)	Reduction Gear Model	Reduction Ratio	Inertia Moment WK <sup>2</sup> (oz•in <sup>2</sup> )	Backlash	Weight (lb)
HC-MF13BG2	100	45	BK1-05B-01MEKA	1/5	0.44	3 min. max.	4.2
HC-MF13BG2	100	45	BK1-09B-01MEKA	1/9	0.40	3 min. max.	4.9
HC-MF13BG2	100	45	BK2-20B-01MEKA	1/20	0.68	3 min. max.	7.5
HC-MF13BG2	100	45	BK2-29B-01MEKA	1/29	0.53	3 min. max.	7.5

Model	Output (W)	Variable Dimensions (in)																	(Reduction Ratio)
		LA	LB	LC	LD	LE	LF	LG	LH	LK	L	LR	KL	LZ	Q	S	P	R	
HC-MF13BG2	100	3.15	2.56	3.74	2.76	0.24	1.89	0.31	2.362	0.906	6.81	2.17	3.66	0.26	0.98	0.63	M4	0.31	1/5
HC-MF13BG2	100	3.15	2.56	3.74	2.76	0.24	1.89	0.31	2.362	0.906	7.44	2.17	4.29	0.26	0.98	0.63	M4	0.31	1/9
HC-MF13BG2	100	3.94	3.15	4.53	3.35	0.24	2.559	0.39	2.913	1.299	7.68	2.95	4.53	0.26	1.38	0.79	M5	0.39	1/20
HC-MF13BG2	100	3.94	3.15	4.53	3.35	0.24	2.559	0.39	2.913	1.299	7.68	2.95	4.53	0.26	1.38	0.79	M5	0.39	1/29

[Unit: in]



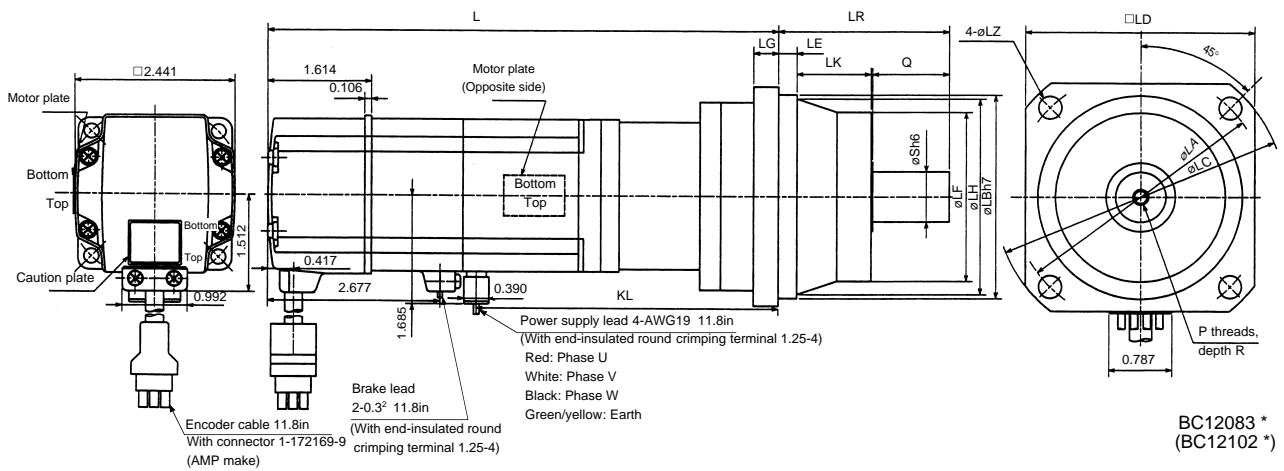
# 10. SPECIFICATIONS

Model	Output (W)	Braking Force (oz·in)	Reduction Gear Model	Reduction Ratio	Inertia Moment WK <sup>2</sup> (oz·in <sup>2</sup> )	Weight (lb)
HC-MF23BG2	200	184	BK1-05B-02MEKA	1/5	1.31	6.0
HC-MF23BG2	200	184	BK2-09B-02MEKA	1/9	1.40	9.0
HC-MF23BG2	200	184	BK3-20B-02MEKA	1/20	2.21	12.3
HC-MF23BG2	200	184	BK3-29B-02MEKA	1/29	1.77	12.3

Model	Output (W)	Variable Dimensions (in)																(Reduction Ratio)	
		LA	LB	LC	LD	LE	LF	LG	LH	LK	L	LR	KL	LZ	Q	S	P		R
HC-MF23BG2	200	3.15	2.56	3.74	2.76	0.24	1.89	0.31	2.362	0.906	7.44	2.17	4.20	0.26	0.98	0.63	M4	0.31	1/5
HC-MF23BG2	200	3.94	3.15	4.53	3.35	0.24	2.559	0.39	2.913	1.299	8.15	2.95	4.91	0.26	1.38	0.79	M5	0.39	1/9
HC-MF23BG2	200	4.53	3.74	5.31	3.94	0.31	2.953	0.39	3.346	1.378	8.35	3.35	5.10	0.35	1.57	0.98	M6	0.47	1/20
HC-MF23BG2	200	4.53	3.74	5.31	3.94	0.31	2.953	0.39	3.346	1.378	8.35	3.35	5.10	0.35	1.57	0.98	M6	0.47	1/29

[Unit: in]

For reverse rotation command  
 "Rotation direction"  
 For forward rotation command

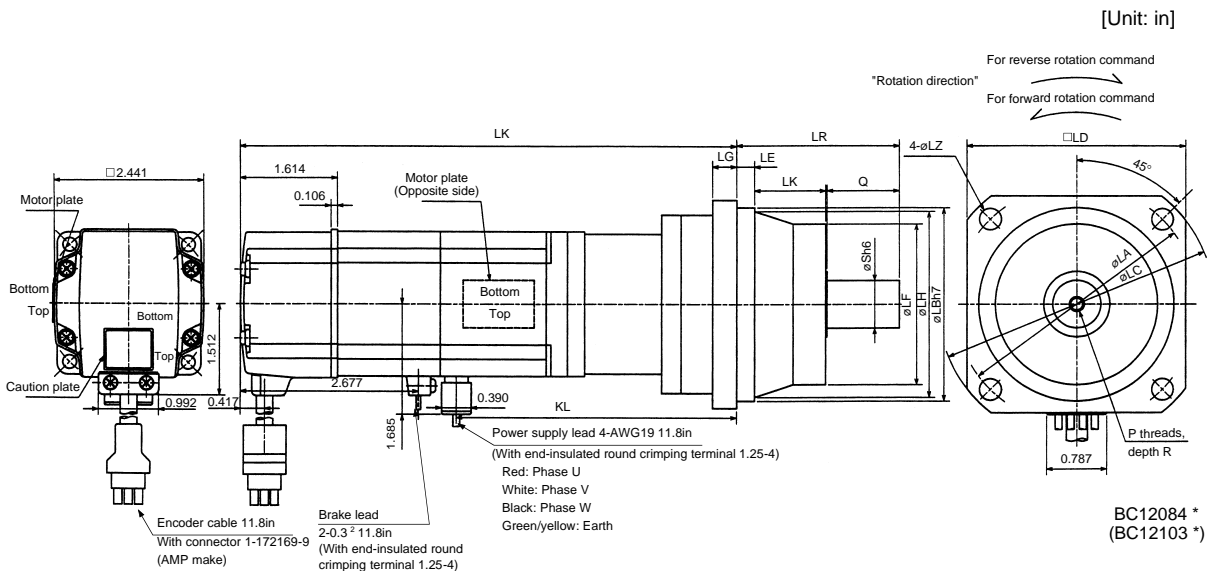


BC12083 \*  
 (BC12102 \*)

# 10. SPECIFICATIONS

Model	Output (W)	Braking Force (oz•in)	Reduction Gear Model	Reduction Ratio	Inertia Moment $WK^2$ (oz•in <sup>2</sup> )	Weight (lb)
HC-MF43BG2	400	184	BK2-05B-04MEKA	1/5	1.88	9.5
HC-MF43BG2	400	184	BK3-09B-04MEKA	1/9	2.03	13.0
HC-MF43BG2	400	184	BK4-20B-04MEKA	1/20	2.59	17.9
HC-MF43BG2	400	184	BK4-29B-04MEKA	1/29	2.11	17.9

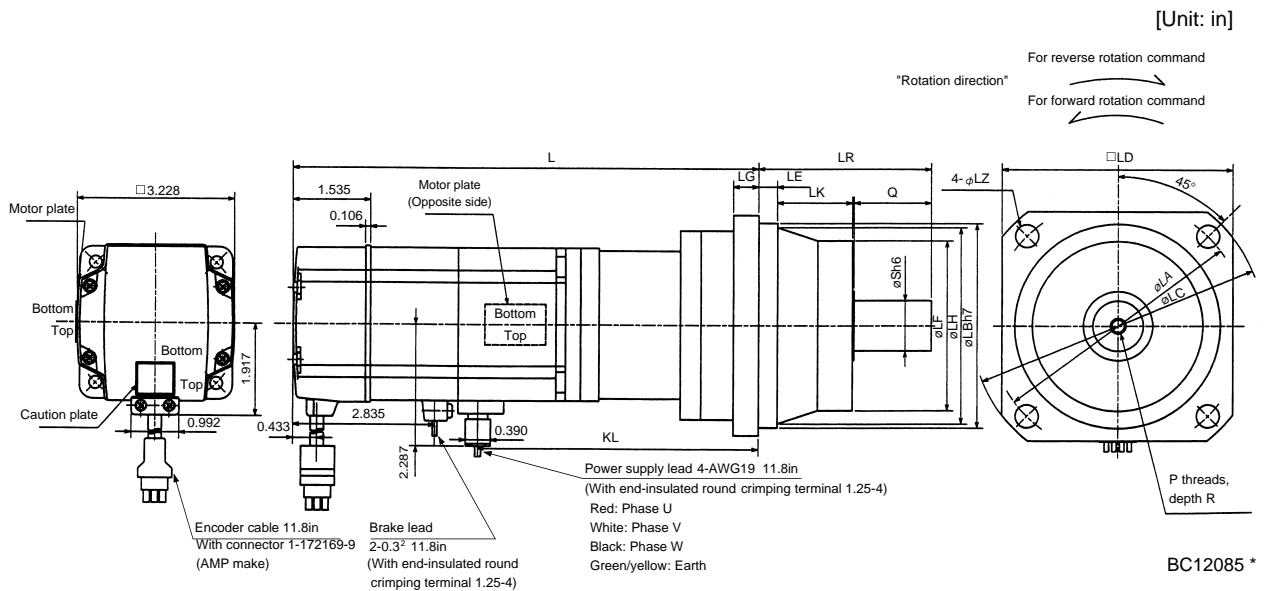
Model	Output (W)	Variable Dimensions (in)																	(Reduction Ratio)
		LA	LB	LC	LD	LE	LF	LG	LH	LK	L	LR	KL	LZ	Q	S	P	R	
HC-MF43BG2	400	3.94	3.15	4.53	3.35	0.24	2.559	0.39	2.913	1.299	8.50	2.95	5.18	0.26	1.38	0.79	M5	0.39	1/5
HC-MF43BG2	400	4.53	3.74	5.31	3.94	0.31	2.953	0.39	3.346	1.378	9.33	3.35	6.01	0.35	1.57	0.98	M6	0.47	1/9
HC-MF43BG2	400	5.31	4.33	6.10	4.53	0.31	3.543	0.47	3.937	1.575	9.57	3.94	6.24	0.43	1.97	1.26	M8	0.63	1/20
HC-MF43BG2	400	5.31	4.33	6.10	4.53	0.31	3.543	0.47	3.937	1.575	9.57	3.94	6.24	0.43	1.97	1.26	M8	0.63	1/29



# 10. SPECIFICATIONS

Model	Output (W)	Braking Force (oz•in)	Reduction Gear Model	Reduction Ratio	Inertia Moment WK <sup>2</sup> (oz•in <sup>2</sup> )	Weight (lb)
HC-MF73BG2	750	340	BK3-05B-08MEKA	1/5	6.00	16.1
HC-MF73BG2	750	340	BK4-09B-08MEKA	1/9	6.04	21.2
HC-MF73BG2	750	340	BK5-20B-08MEKA	1/20	6.24	28.7
HC-MF73BG2	750	340	BK5-29B-08MEKA	1/29	5.66	28.7

Model	Output (W)	Variable Dimensions (in)																	(Reduction Ratio)
		LA	LB	LC	LD	LE	LF	LG	LH	LK	L	LR	KL	LZ	Q	S	P	R	
HC-MF73BG2	750	4.53	3.74	5.31	3.94	0.31	2.953	0.39	3.346	1.378	9.74	3.35	6.17	0.35	1.57	0.98	M6	0.47	1/5
HC-MF73BG2	750	5.31	4.33	6.10	4.53	0.31	3.543	0.47	3.937	1.575	11.16	3.94	7.59	0.43	1.97	1.26	M8	0.63	1/9
HC-MF73BG2	750	5.91	4.92	6.89	5.12	0.39	4.134	0.59	4.528	1.693	11.16	4.53	7.59	0.55	2.36	1.57	M10	0.79	1/20
HC-MF73BG2	750	5.91	4.92	6.89	5.12	0.39	4.134	0.59	4.528	1.693	11.16	4.53	7.59	0.55	2.36	1.57	M10	0.79	1/29

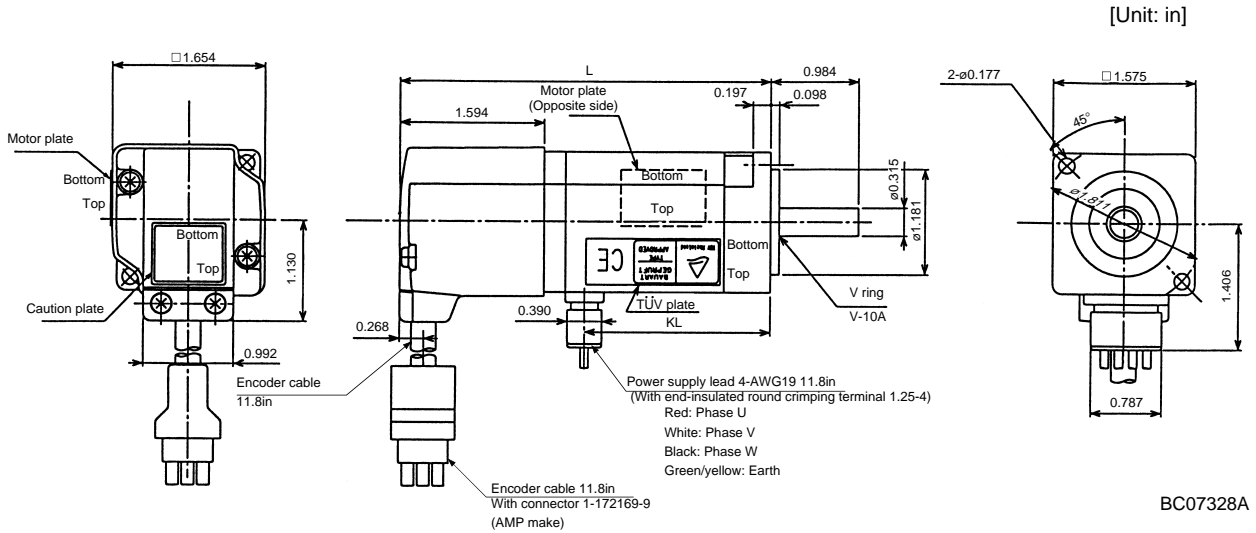


# 10. SPECIFICATIONS

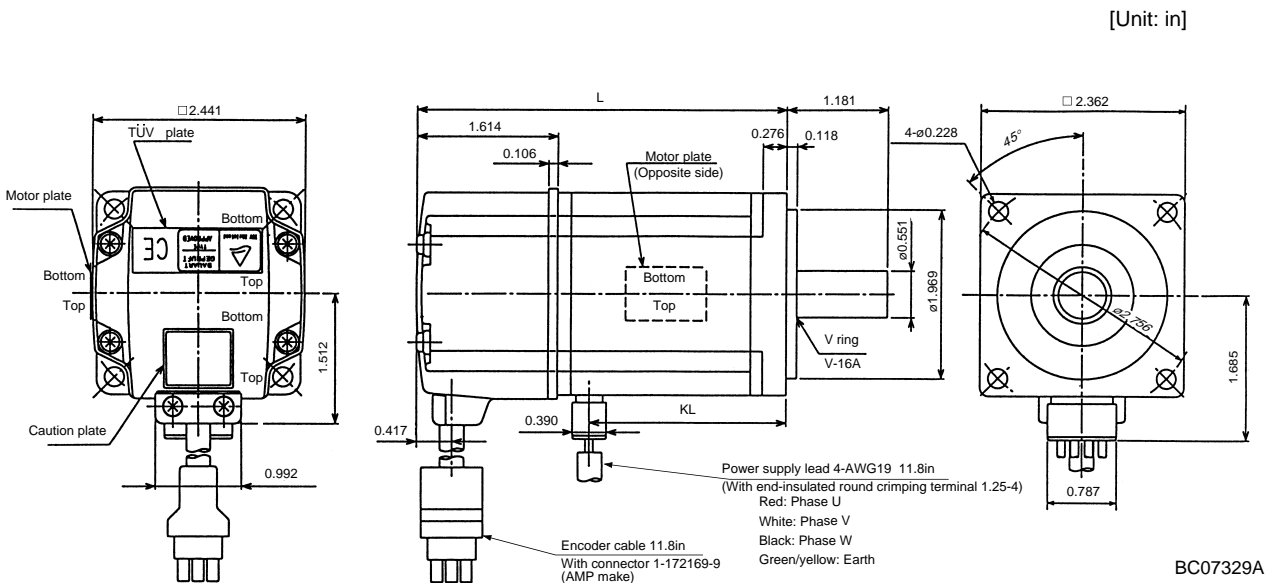
## (2) HC-MF-UE series

### 1) Standard (Without electromagnetic brake, without reduction gear)

Model	Output (W)	Variable Dimensions (in)		Inertia Moment $WK^2(oz\cdot in^2)$	Weight (lb)
		L	KL		
HC-MF053-UE	50	3.52	1.48	0.10	1.1
HC-MF13-UE	100	4.11	2.07	0.16	1.3



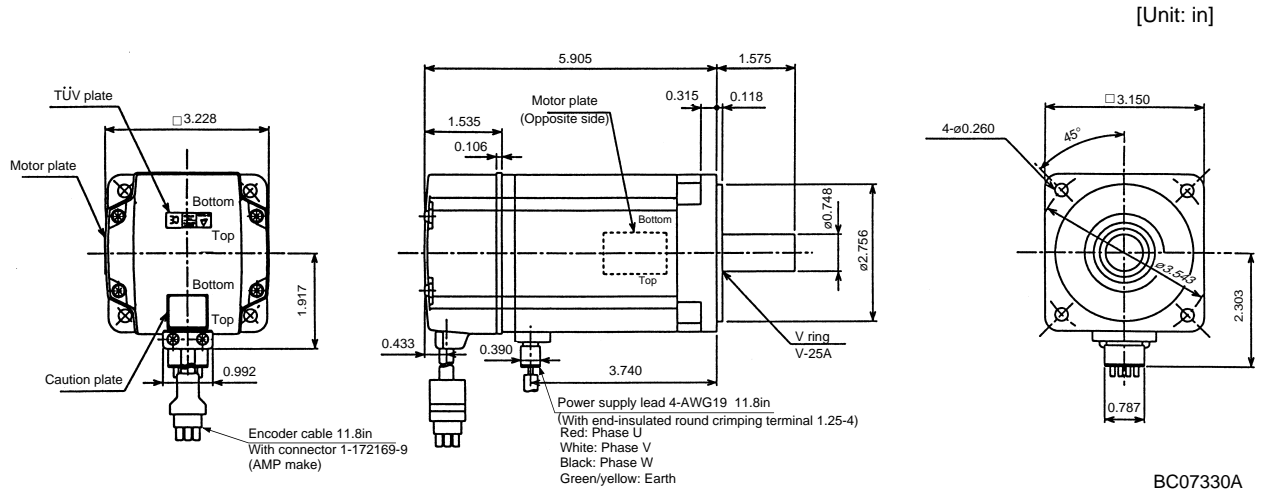
Model	Output (W)	Variable Dimensions (in)		Inertia Moment $WK^2(oz\cdot in^2)$	Weight (lb)
		L	KL		
HC-MF23-UE	200	4.27	2.28	0.49	2.6
HC-MF43-UE	400	5.26	3.19	0.77	3.7





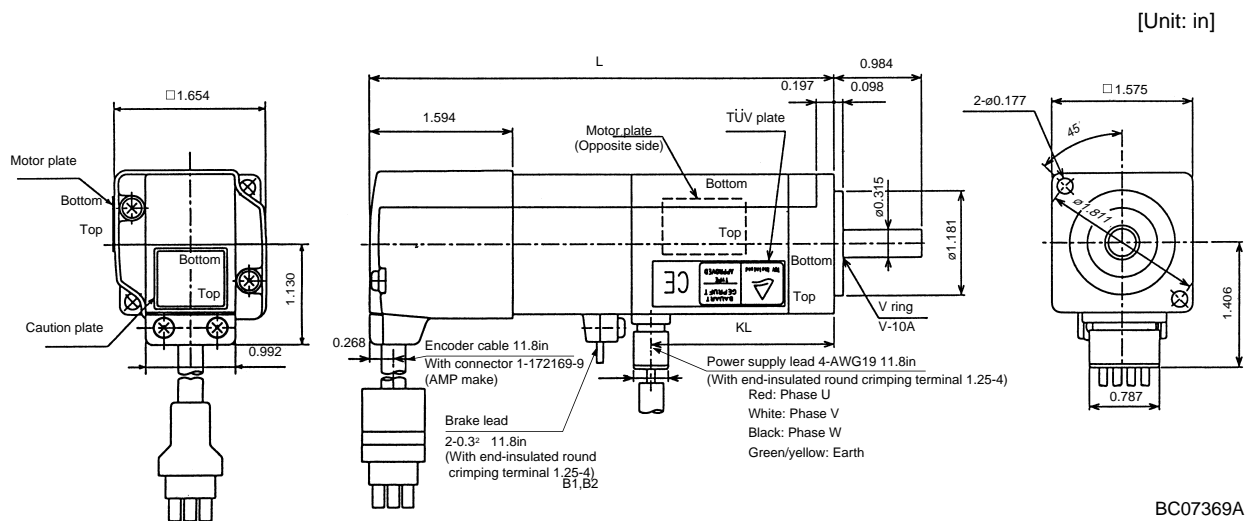
# 10. SPECIFICATIONS

Model	Output (W)	Inertia Moment $WK^2(oz\cdot in^2)$	Weight (lb)
HC-MF73-UE	750	3.69	6.8



## 2) With electromagnetic brake

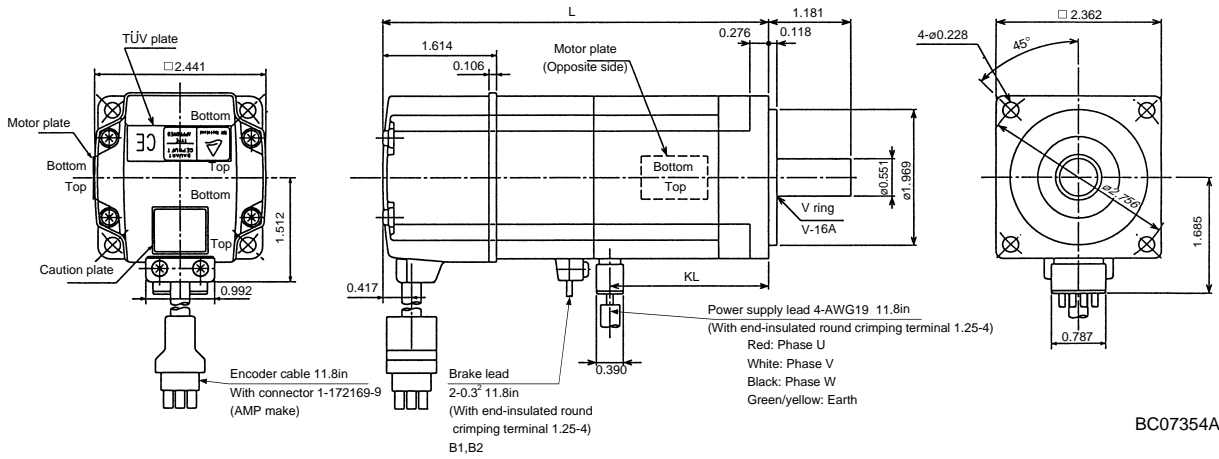
Model	Output (W)	Variable Dimensions (in)		Barking Force (oz·in)	Inertia Moment $WK^2(oz\cdot in^2)$	Weight (lb)
		L	KL			
HC-MF053B-UE	50	4.63	1.48	45	0.12	2.0
HC-MF13B-UE	100	5.22	2.08	45	0.18	2.2



# 10. SPECIFICATIONS

Model	Output (W)	Variable Dimensions (in)		Barking Force (oz•in)	Inertia Moment WK <sup>2</sup> (oz•in <sup>2</sup> )	Weight (lb)
		L	KL			
HC-MF23B-UE	200	5.53	2.28	184	0.47	3.7
HC-MF43B-UE	400	6.52	3.19	184	1.04	4.9

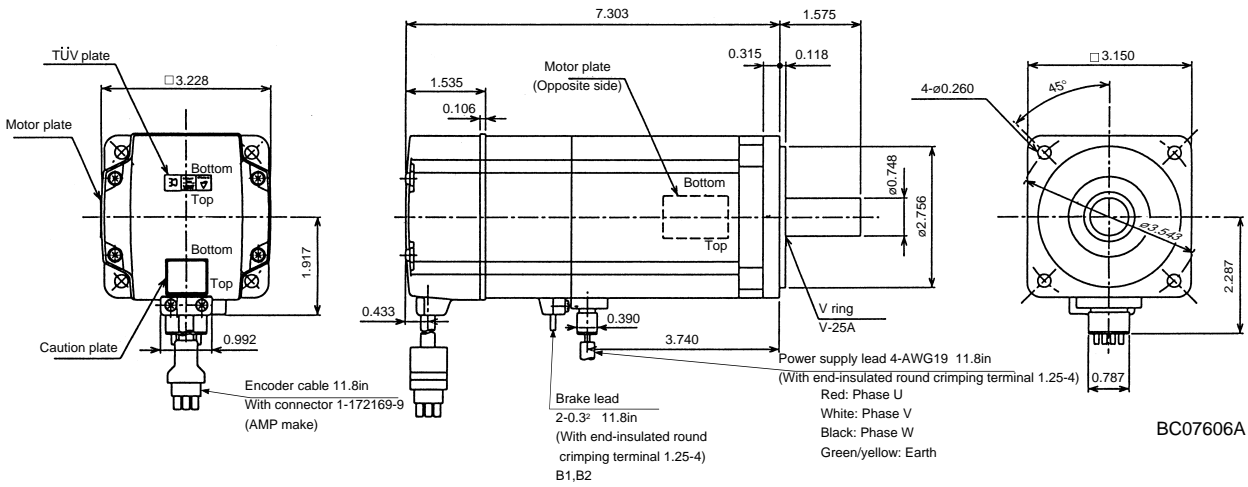
[Unit: in]



BC07354A

Model	Output (W)	Barking Force (oz•in)	Inertia Moment WK <sup>2</sup> (oz•in <sup>2</sup> )	Weight (lb)
HC-MF73B-UE	750	340	4.10	9.3

[Unit: in]



BC07606A

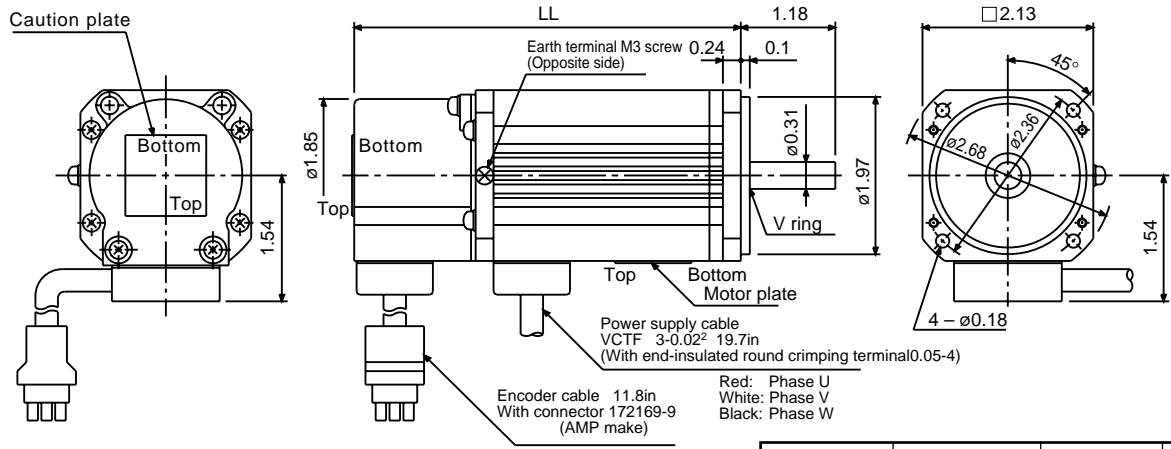
# 10. SPECIFICATIONS

## (3) HA-FF series

### 1) Standard

HA – FF053 • HA – FF13

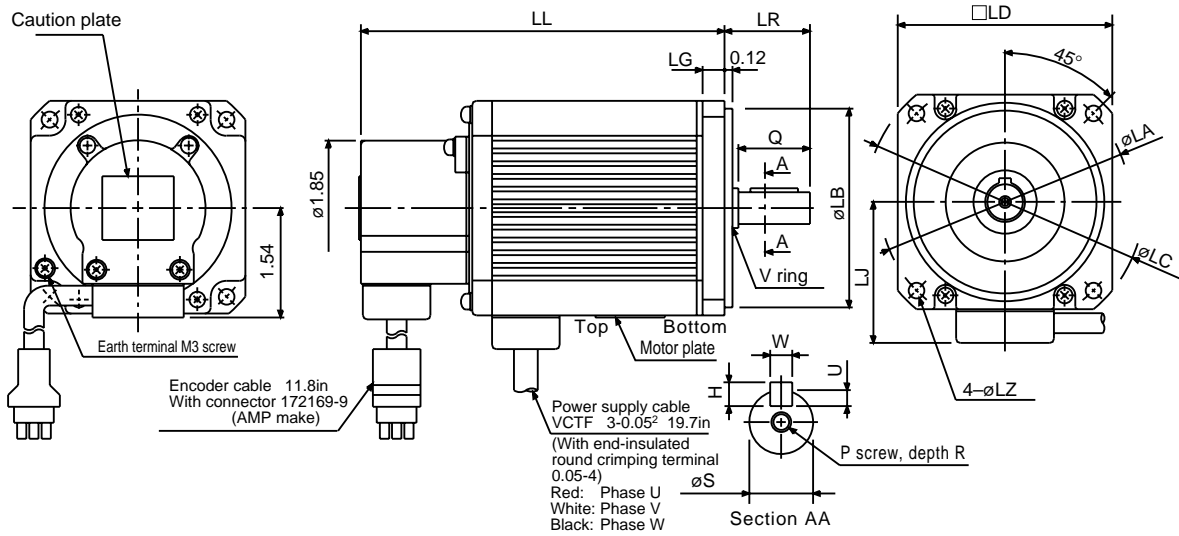
[Unit: in]



Servo Motor Model	Inertia Moment WK <sup>2</sup> [oz•in <sup>2</sup> ]	Variable Dimensions LL	Weight [lb]
HA-FF053	0.342	4.17	2.9
HA-FF13	0.519	4.84	3.3

HA – FF23 to HA – FF63

[Unit: in]



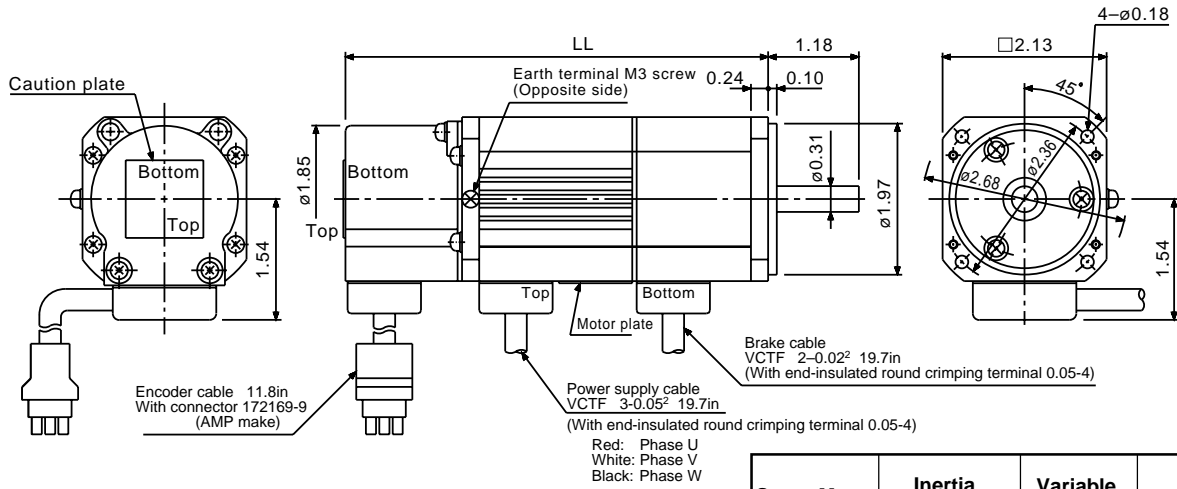
Servo Motor Model	Inertia Moment WK <sup>2</sup> [oz•in <sup>2</sup> ]	Variable Dimensions															Weight [lb]	
		LA	LB	LC	LD	LG	LJ	LL	LR	LZ	H	Q	S	U	W	P		R
HA-FF23	1.91	3.54	2.76	3.94	2.99	0.31	1.97	5.16	1.18	0.22	0.16	0.98	0.43	0.10	0.16	M4	0.59	5.1
HA-FF33	2.73	3.54	2.76	3.94	2.99	0.31	1.97	5.83	1.18	0.22	0.16	0.98	0.43	0.10	0.16	M4	0.59	5.7
HA-FF43	5.33	4.53	3.74	5.31	3.94	0.39	2.44	6.08	1.57	0.35	0.20	1.38	0.63	0.12	0.20	M5	0.79	9.3
HA-FF63	6.56	4.53	3.74	5.31	3.94	0.39	2.44	6.67	1.57	0.35	0.20	1.38	0.63	0.12	0.20	M5	0.79	10.6

# 10. SPECIFICATIONS

## 2) With electromagnetic brake

HA – FF053B • HA – FF13B

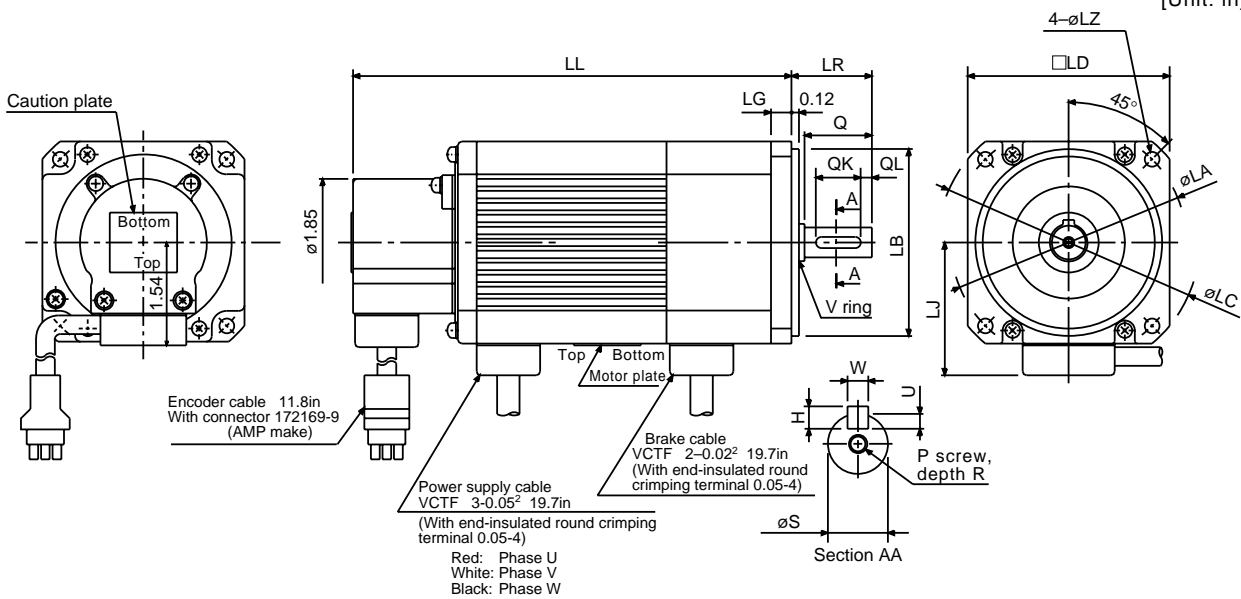
[Unit: in]



Servo Motor Model	Inertia Moment WK <sup>2</sup> [oz·in <sup>2</sup> ]	Variable Dimensions LL	Weight [lb]
HA-FF053	0.437	5.53	3.5
HA-FF13B	0.615	6.20	4.0

HA – FF23B to HA – FF63B

[Unit: in]



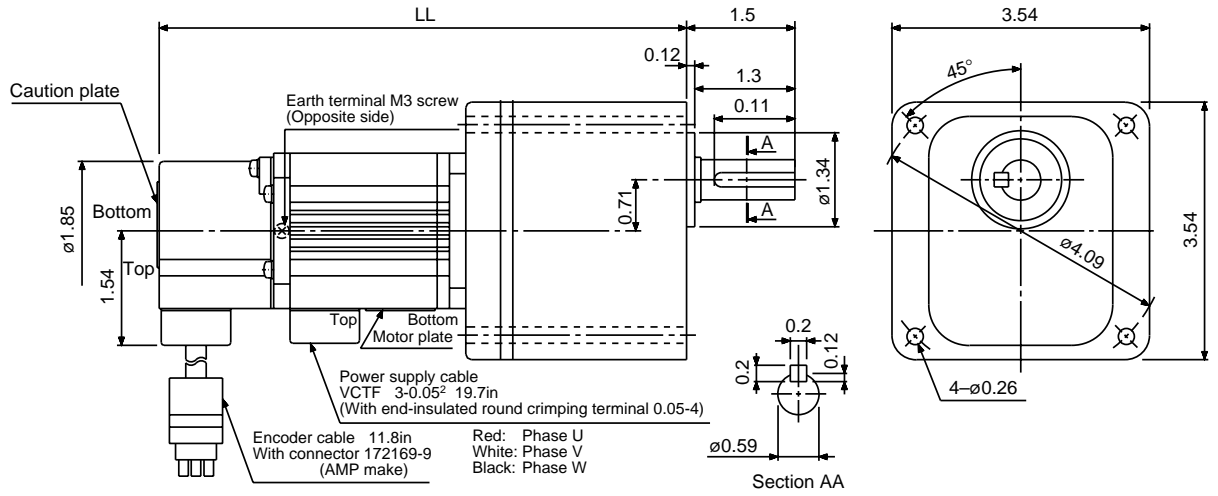
Servo Motor Model	Inertia Moment WK <sup>2</sup> [oz·in <sup>2</sup> ]	Variable Dimensions [in]															Weight [lb]	
		LA	LB	LC	LD	LG	LJ	LL	LR	LZ	H	Q	S	U	W	P		R
HA-FF23B	2.64	3.54	2.76	3.94	2.99	0.31	1.97	6.59	1.18	0.22	0.16	0.98	0.43	0.10	0.16	M4	0.59	6.4
HA-FF33B	3.46	3.54	2.76	3.94	2.99	0.31	1.97	7.28	1.18	0.22	0.16	0.98	0.43	0.10	0.16	M4	0.59	7.1
HA-FF43B	7.24	4.53	3.74	5.31	3.94	0.39	2.44	7.54	1.57	0.35	0.20	1.38	0.63	0.12	0.20	M5	0.79	11.0
HA-FF63B	8.47	4.53	3.74	5.31	3.94	0.39	2.44	8.13	1.57	0.35	0.20	1.38	0.63	0.12	0.20	M5	0.79	12.3

# 10. SPECIFICATIONS

## 3) With reduction gear for general industrial machine

HA – FF053(B)G1 • HA – FF13(B)G1

[Unit: in]

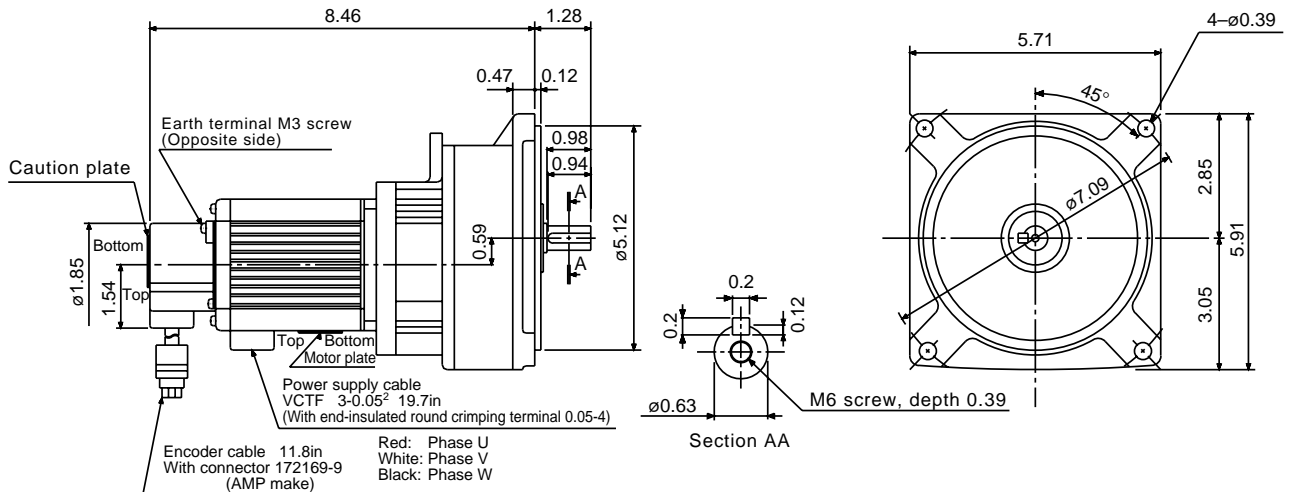


Servo Motor Model	(Note 2) Reduction Ratio	Reduction Gear Model	Inertia Moment WK <sup>2</sup> [oz·in <sup>2</sup> ]	(Note 1) Variable Dimensions LL	(Note 1) Weight [lb]
HA-FF053 (B)G1	1/5	GR – S – 10	0.369 (0.465)	7.20 (8.56)	5.5 (6.2)
	1/10		0.369 (0.465)	7.20 (8.56)	5.5 (6.2)
	1/30		0.342 (0.437)	7.20 (8.56)	5.5 (6.2)
HA-FF13 (B)G1	1/5	GR – S – 10	0.547 (0.629)	7.87 (9.23)	6.0 (6.6)
	1/10		0.547 (0.629)	7.87 (9.23)	6.0 (6.6)
	1/30		0.519 (0.601)	7.87 (9.23)	6.0 (6.6)

Note: 1. Values in parentheses are those for the servo motors with electromagnetic brakes.  
2. Nominal reduction ratios. For actual reduction ratios, refer to Section 10-3.

HA – FF23(B)G1

[Unit: in]



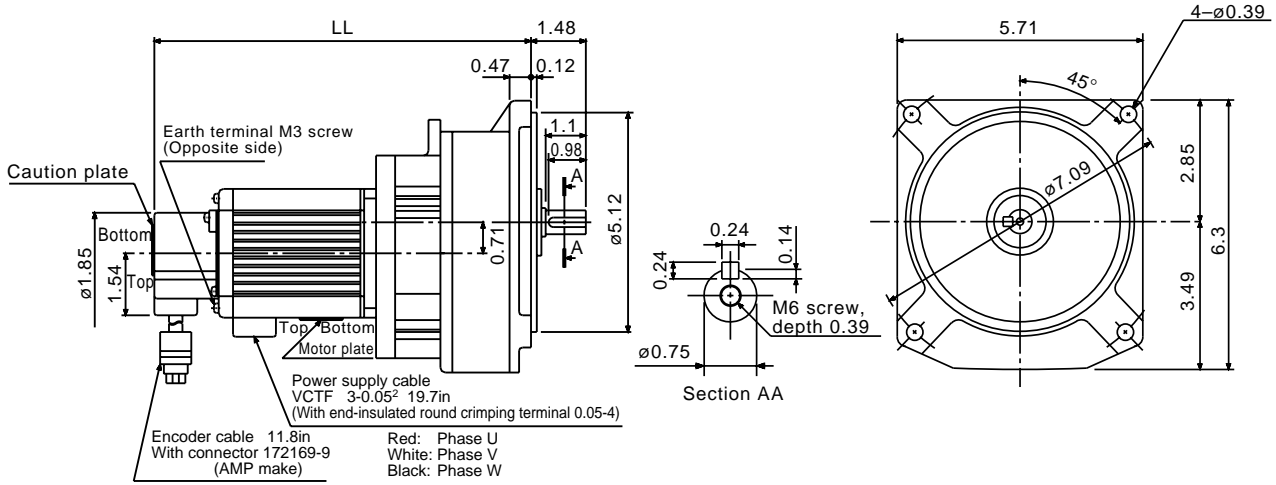
Servo Motor Model	(Note 2) Reduction Ratio	Reduction Gear Model	Inertia Moment WK <sup>2</sup> [oz·in <sup>2</sup> ]	(Note 1) Weight [lb]
HA-FF23 (B)G1	1/5	GR-S-20	2.037 (4.114)	11 (12.3)
	1/10		2.037 (4.114)	11 (12.3)
	1/30		2.037 (4.114)	11 (12.3)

Note: 1. Values in parentheses are those for the servo motors with electromagnetic brakes.  
2. Nominal reduction ratios. For actual reduction ratios, refer to Section 10-3.

# 10. SPECIFICATIONS

HA – FF33(B)G1 • HA – FF43(B)G1

[Unit: in]

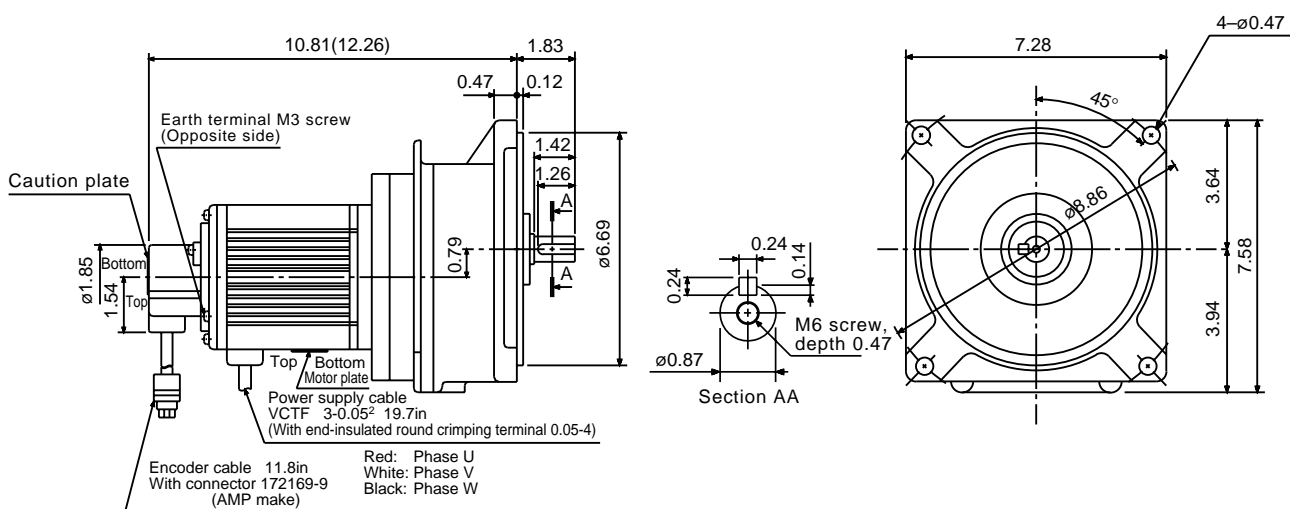


Servo Motor Model	(Note 2) Reduction Ratio	Reduction Gear Model	Inertia Moment WK <sup>2</sup> [oz·in <sup>2</sup> ]	(Note 1) Variable Dimensions LL	(Note 1) Weight [lb]
HA-FF33 (B)G1	1/5	GR-S-30	2.980 (3.704)	9.84 (11.3)	14.3 (15.9)
	1/10		2.980 (3.704)	9.84 (11.3)	14.3 (15.9)
	1/30		2.939 (3.663)	9.84 (11.3)	14.3 (15.9)
HA-FF43 (B)G1	1/5	GR-S-40	5.577 (7.490)	10.2 (11.63)	17.6 (19.6)
	1/10		5.577 (7.490)	10.2 (11.63)	17.6 (19.6)
	1/30		5.536 (7.449)	10.2 (11.63)	17.6 (19.6)

Note: 1. Values in parentheses are those for the servo motors with electromagnetic brakes.  
 2. Nominal reduction ratios. For actual reduction ratios, refer to Section 10-3.

HA – FF63(B)G1

[Unit: in]

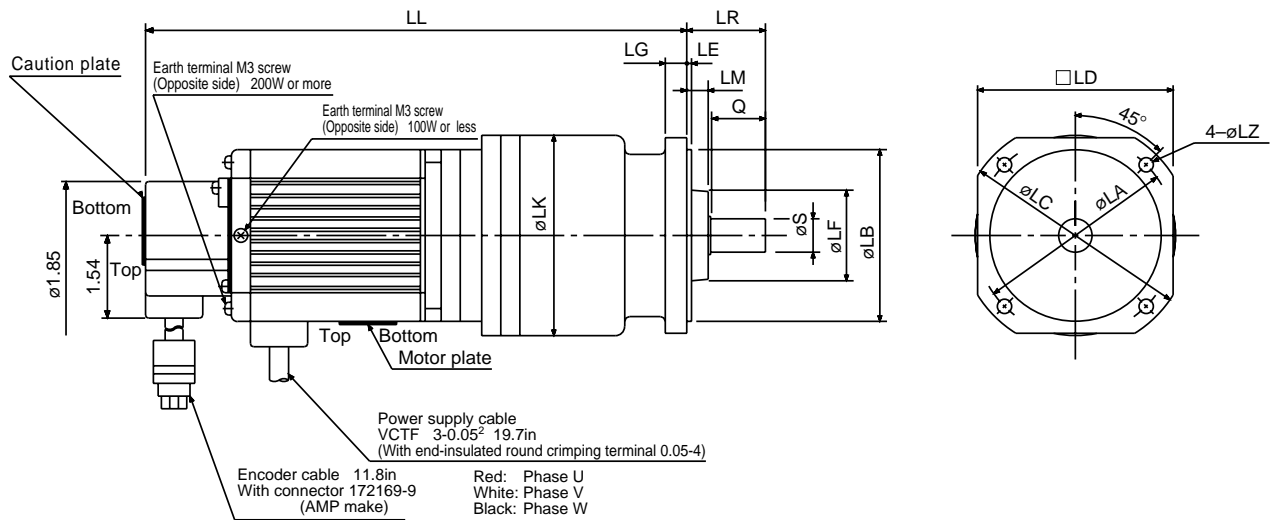


Servo Motor Model	(Note 2) Reduction Ratio	Reduction Gear Model	Inertia Moment WK <sup>2</sup> [oz·in <sup>2</sup> ]	(Note 1) Weight [lb]
HA-FF63 (B)G1	1/5	GR-S-60	7.326 (9.240)	28.7 (30.6)
	1/10		7.326 (9.240)	28.7 (30.6)
	1/30		7.217 (9.131)	28.7 (30.6)

Note: 1. Values in parentheses are those for the servo motors with electromagnetic brakes.  
 2. Nominal reduction ratios. For actual reduction ratios, refer to Section 10-3.

# 10. SPECIFICATIONS

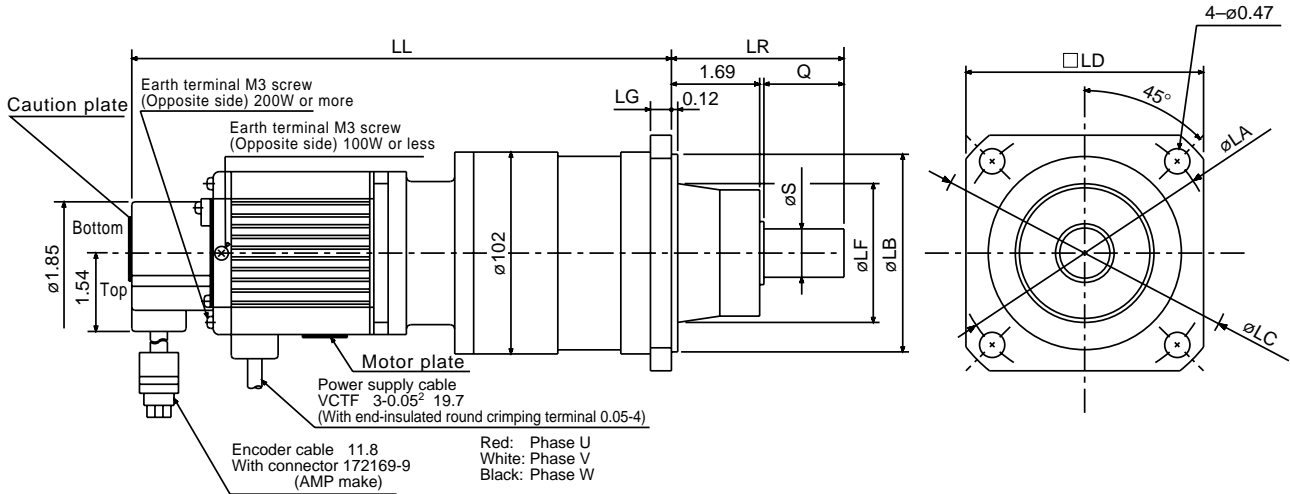
## 4) With reduction gear for precision application



Servo Motor Model	Reduction Ratio	Reduction Gear Model	(Note) Inertia Moment WK <sup>2</sup> [oz·in <sup>2</sup> ]	(Note) Variable Dimensions [in]													(Note) Weight [lb]	
				LA	LB	LC	LD	LE	LF	LG	LK	LL	LM	LR	LZ	Q		S
HA-FF053 (B)G2	1/5	BM2-05B -A5MES	0.60 (0.70)	3.07	2.44	3.50	2.91	0.08	1.30	0.24	2.95	8.07 (9.45)	0.35	1.18	0.18	0.79	10.0	5.1 (5.7)
	1/10	BM2-10B -A5MES	0.59 (0.68)	3.07	2.44	3.50	2.91	0.08	1.30	0.24	2.95	8.07 (9.43)	0.35	1.18	0.18	0.79	10.0	5.1 (5.7)
	1/15	BM2-15B -A5MES	0.57 (0.67)	3.07	2.44	3.50	2.91	0.08	1.30	0.24	2.95	8.07 (9.43)	0.35	1.18	0.18	0.79	10.0	5.1 (5.7)
	1/25	BM3-25B -A5MES	0.60 (0.66)	3.54	2.99	4.02	3.43	0.08	1.61	0.31	3.54	8.39 (9.74)	0.35	1.38	0.22	0.98	14.0	6.2 (7.1)
HA-FF13 (B)G2	1/5	BM2-05B -01MES	0.78 (0.87)	3.07	2.44	3.50	2.91	0.08	1.30	0.24	2.95	8.74 (10.10)	0.35	1.18	0.18	0.79	10.0	5.5 (6.2)
	1/10	BM3-10B -01MES	0.90 (0.87)	3.54	2.99	4.02	3.43	0.08	1.61	0.31	3.54	9.06 (10.41)	0.35	1.38	0.22	0.98	14.0	6.6 (7.5)
	1/15	BM3-15B -01MES	0.85 (0.83)	3.54	2.99	4.02	3.43	0.08	1.61	0.31	3.54	9.06 (10.41)	0.35	1.38	0.22	0.98	14.0	6.6 (7.5)
	1/25	BM4-25B -01MES	1.59 (1.68)	4.80	3.94	5.51	4.65	0.12	2.40	0.39	4.65	10.31 (11.67)	0.55	2.17	0.26	1.57	22.0	11.0 (11.7)
HA-FF23 (B)G2	1/5	BM3-05B -02MES	2.32 (3.05)	3.54	2.99	4.02	3.43	0.08	1.61	0.31	3.54	9.45 (10.91)	0.35	1.38	0.22	0.98	14.0	8.4 (9.7)
	1/10	BM4-10B -02MES	3.53 (4.25)	4.80	3.94	5.51	4.65	0.12	2.40	0.39	4.65	10.63 (12.07)	0.55	2.17	0.26	1.57	22.0	12.8 (14.1)
	1/15	BM4-15B -02MES	3.38 (4.10)	4.80	3.94	5.51	4.65	0.12	2.40	0.39	4.65	10.63 (12.07)	0.55	2.17	0.26	1.57	22.0	12.8 (14.1)
HA-FF33 (B)G2	1/5	BM4-05B -03MES	4.47 (5.19)	4.80	3.94	5.51	4.65	0.12	2.40	0.39	4.65	11.30 (12.78)	0.55	2.17	0.26	1.57	22.0	13.4 (14.8)
	1/10	BM4-10B -03MES	4.35 (5.07)	4.80	3.94	5.51	4.65	0.12	2.40	0.39	4.65	11.30 (12.78)	0.55	2.17	0.26	1.57	22.0	13.4 (14.8)
HA-FF43 (B)G2	1/5	BM4-05B -04MES	7.07 (8.98)	4.80	3.94	5.51	4.65	0.12	2.40	0.39	4.65	11.97 (13.41)	0.55	2.17	0.26	1.57	22.0	17.0 (18.7)

Note: Values in parentheses are those for the servo motors with electromagnetic brakes.

# 10. SPECIFICATIONS



Servo Motor Model	Reduction Ratio	Reduction Gear Model	(Note) Inertia Moment WK <sup>2</sup> [oz·in <sup>2</sup> ]	Variable Dimensions [in]										Weight [lb]	
				LA	LB	LC	LD	LF	LG	LK	LL	LR	Q		S
HA-FF13 (B)G2	1/45	BL1-45B-01MES	1.60 (1.63)	5.12	3.94	6.10	4.72	2.76	0.39	4.02	10.79 (12.15)	3.35	1.57	0.98	13.2 (13.9)
HA-FF23 (B)G2	1/20	BL1-20B-02MES	3.99 (4.84)	5.12	3.94	6.10	4.72	2.76	0.39	4.02	10.94 (12.26)	3.35	1.57	0.98	15.0 (16.3)
	1/29	BL1-29B-02MES	3.46 (4.18)	5.12	3.94	6.10	4.72	2.76	0.39	4.02	10.94 (12.38)	3.35	1.57	0.98	15.0 (16.3)
	1/45	BL2-45B-02MES	4.17 (4.89)	6.30	5.12	7.28	5.51	3.70	0.47	5.20	11.77 (13.23)	3.94	2.17	1.38	27.1 (28.4)
HA-FF33 (B)G2	1/20	BL1-20B-03MES	4.81 (5.54)	5.12	3.94	6.10	4.72	2.76	0.39	4.02	11.61 (12.97)	3.35	1.57	0.98	15.7 (17.0)
	1/29	BL2-29B-03MES	8.39 (9.12)	6.30	5.12	7.28	5.51	3.70	0.47	5.20	12.44 (13.92)	3.94	2.17	1.38	27.8 (29.1)
	1/45	BL2-45B-03MES	4.99 (5.71)	6.30	5.12	7.28	5.51	3.70	0.47	5.20	12.44 (14.31)	3.94	2.17	1.38	27.8 (29.1)
HA-FF43 (B)G2	1/9	BL1-09B-04MES	6.52 (8.43)	5.12	3.94	6.10	4.72	2.76	0.39	4.02	11.63 (13.09)	3.35	1.57	0.98	18.1 (19.8)
	1/20	BL2-20B-04MES	13.00 (14.91)	6.30	5.12	7.28	5.51	3.70	0.47	5.20	12.74 (14.19)	3.94	2.17	1.38	31.3 (33.1)
	1/29	BL2-29B-04MES	10.99 (12.90)	6.30	5.12	7.28	5.51	3.70	0.47	5.20	12.74 (14.19)	3.94	2.17	1.38	31.3 (33.1)
	1/45	BL2-45B-04MES	7.59 (9.50)	6.30	5.12	7.28	5.51	3.70	0.47	5.20	13.13 (14.59)	3.94	2.17	1.38	31.3 (33.1)
HA-FF63 (B)G2	1/5	BL1-05B-06MES	7.01 (10.16)	5.12	3.94	6.10	4.72	2.76	0.39	4.02	11.83 (13.29)	3.35	1.57	0.98	19.4 (21.2)
	1/9	BL1-09B-06MES	7.75 (9.66)	5.12	3.94	6.10	4.72	2.76	0.39	4.02	12.22 (13.68)	3.35	1.57	0.98	19.4 (21.2)
	1/20	BL2-20B-06MES	14.23 (16.14)	6.30	5.12	7.28	5.51	3.70	0.47	5.20	13.33 (14.78)	3.94	2.17	1.38	32.6 (34.4)
	1/29	BL2-29B-06MES	12.22 (14.13)	6.30	5.12	7.28	5.51	3.70	0.47	5.20	13.33 (14.78)	3.94	2.17	1.38	32.6 (34.4)

Note: Values in parentheses are those for the servo motors with electromagnetic brakes.





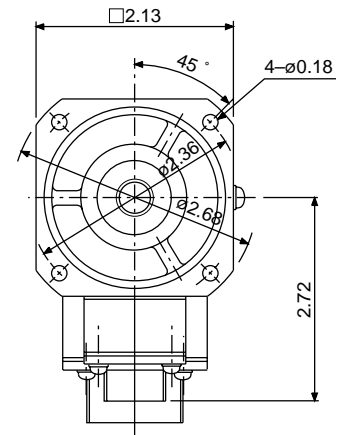
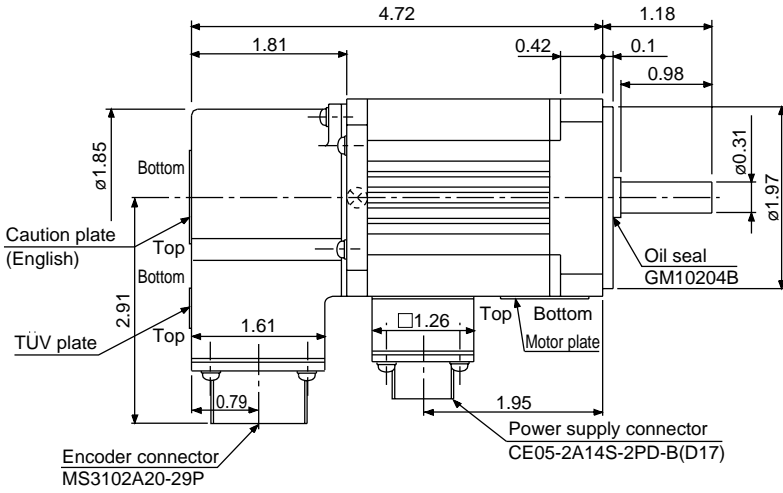
# 10. SPECIFICATIONS

## (4) HA-FFC-UE series

### 1) Standard (without electromagnetic brake, without reduction gear)

HA – FF053C – UE

[Unit: in]

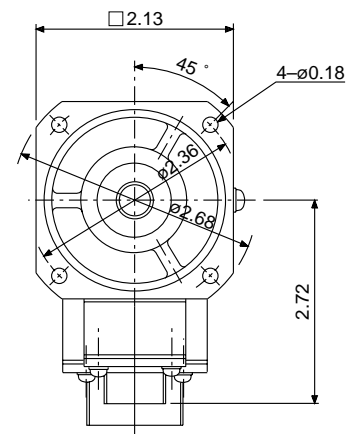
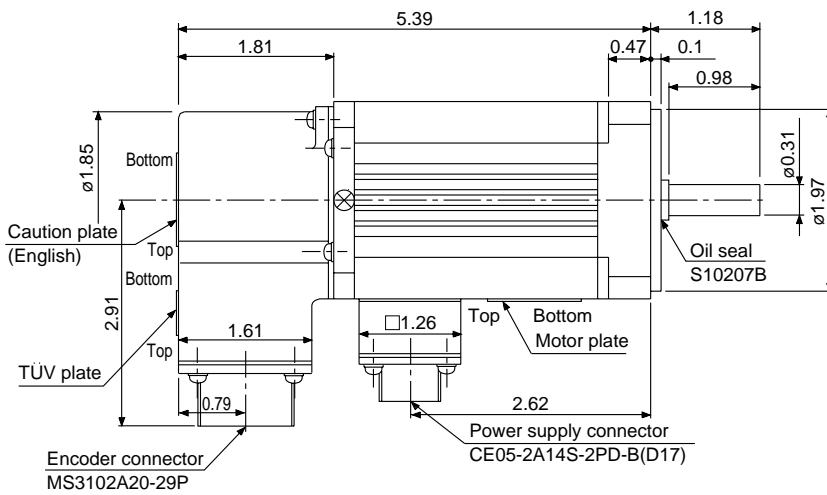


Model	Output [W]	Inertia Moment WK <sup>2</sup> [oz-in <sup>2</sup> ]	Weight [lb]
HA-FF053C-UE	50	0.342	4.0

Note: 1. For the pin-outs of the power supply and encoder connectors, refer to (3), Section 3-2-3.  
2. For horizontal installation, it is recommended to face the power supply and encoder connectors down.

HA – FF13C – UE

[Unit: in]



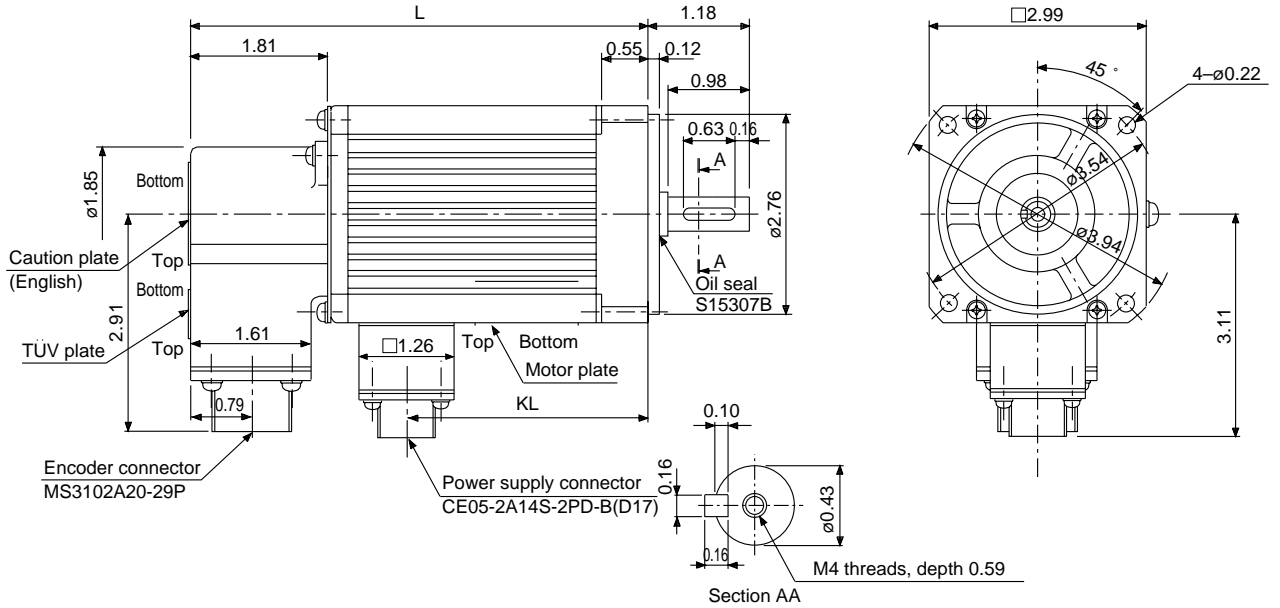
Model	Output [W]	Inertia Moment WK <sup>2</sup> [oz-in <sup>2</sup> ]	Weight [lb]
HA-FF13C-UE	100	0.519	4.4

Note: 1. For the pin-outs of the power supply and encoder connectors, refer to (3), Section 3-2-3.  
2. For horizontal installation, it is recommended to face the power supply and encoder connectors down.

# 10. SPECIFICATIONS

HA – FF23C – UE • HA – FF33C – UE

[Unit: in]

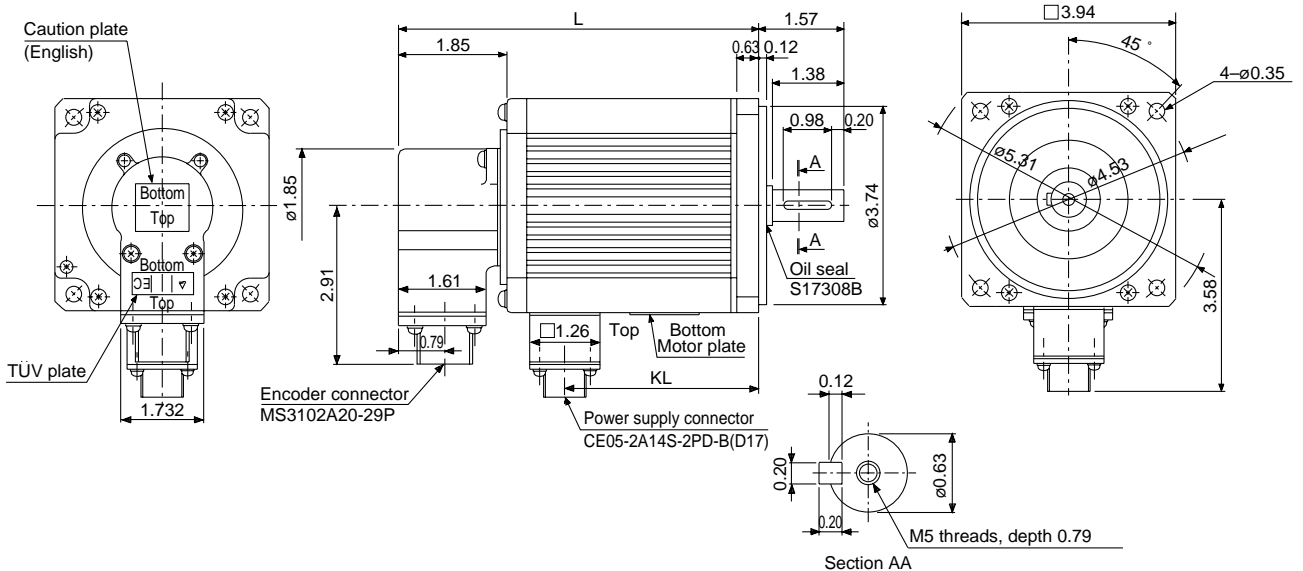


- Note: 1. For the pin-outs of the power supply and encoder connectors, refer to (3), Section 3-2-3.  
 2. For horizontal installation, it is recommended to face the power supply and encoder connectors down.

Model	Output [W]	Variable Dimensions		Inertia Moment WK <sup>2</sup> [oz-in <sup>2</sup> ]	Weight [lb]
		L	KL		
HA-FF23C-UE	200	5.71	2.82	1.91	5.7
HA-FF33C-UE	300	6.38	3.50	2.73	6.4

HA-FF43C-UE • HA-FF63C-UE

[Unit: in]



- Note: 1. For the pin-outs of the power supply and encoder connectors, refer to (3), Section 3-2-3.  
 2. For horizontal installation, it is recommended to face the power supply and encoder connectors down.

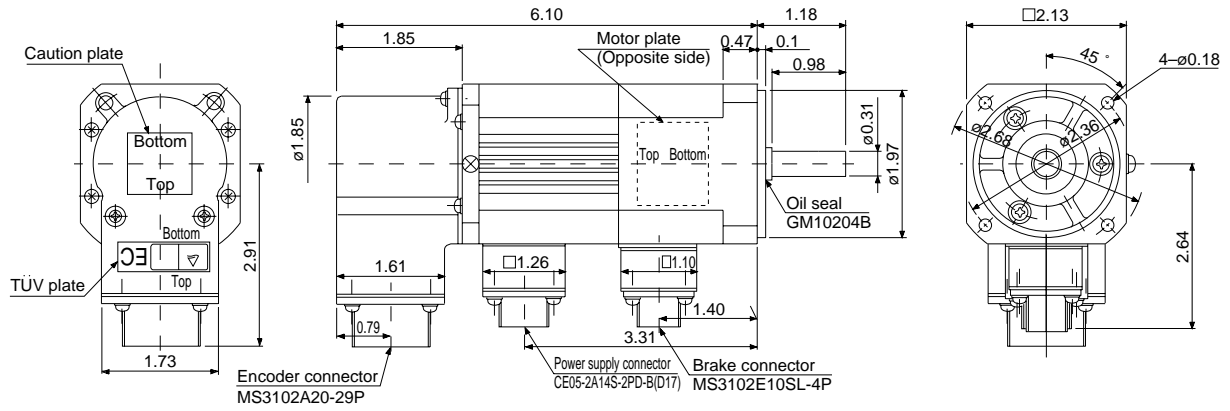
Model	Output [W]	Variable Dimensions		Inertia Moment WK <sup>2</sup> [oz-in <sup>2</sup> ]	Weight [lb]
		L	KL		
HA-FF43C-UE	400	6.65	3.66	5.33	10.4
HA-FF63C-UE	600	7.24	4.25	6.56	11.7

# 10. SPECIFICATIONS

## 2) With electromagnetic brake

HA – FF053CB – UE

[Unit: in]

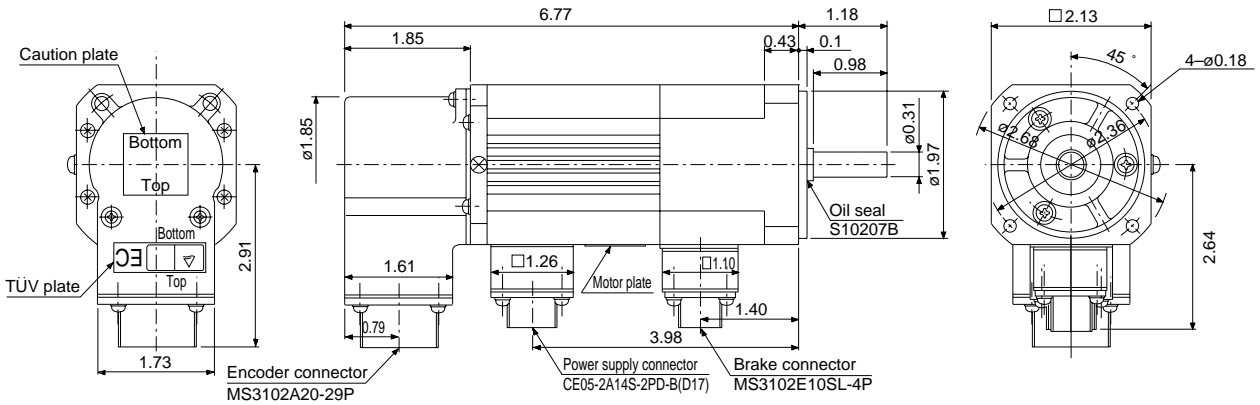


- Note: 1. For the pin-outs of the power supply and encoder connectors, refer to (3), Section 3-2-3.  
 2. For horizontal installation, it is recommended to face the power supply and encoder connectors down.

Model	Output [W]	Inertia Moment WK <sup>2</sup> [oz-in <sup>2</sup> ]	Braking Force [oz-in]	Weight [lb]
HA-FF053CB-UE	50	0.437	55	4.6

HA – FF13CB – UE

[Unit: in]



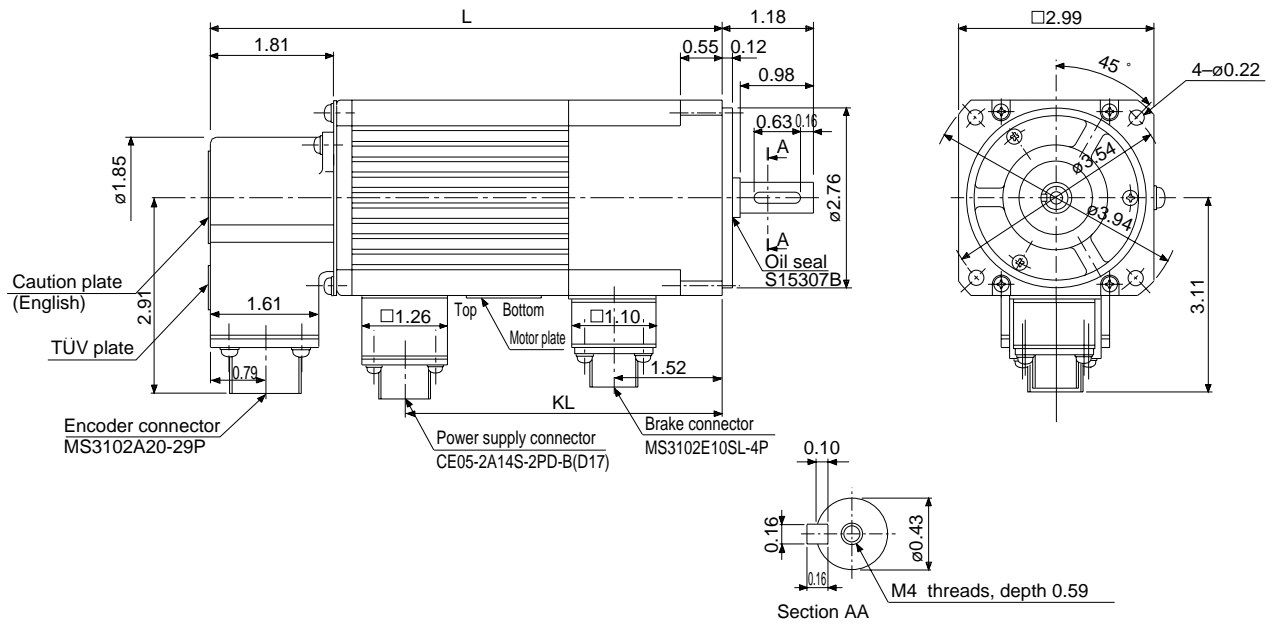
- Note: 1. For the pin-outs of the power supply and encoder connectors, refer to (3), Section 3-2-3.  
 2. For horizontal installation, it is recommended to face the power supply and encoder connectors down.

Model	Output [W]	Inertia Moment WK <sup>2</sup> [oz-in <sup>2</sup> ]	Braking Force [oz-in]	Weight [lb]
HA-FF13CB-UE	100	0.615	55	5.1

# 10. SPECIFICATIONS

HA – FF23CB – UE • HA – FF33CB – UE

[Unit: in]

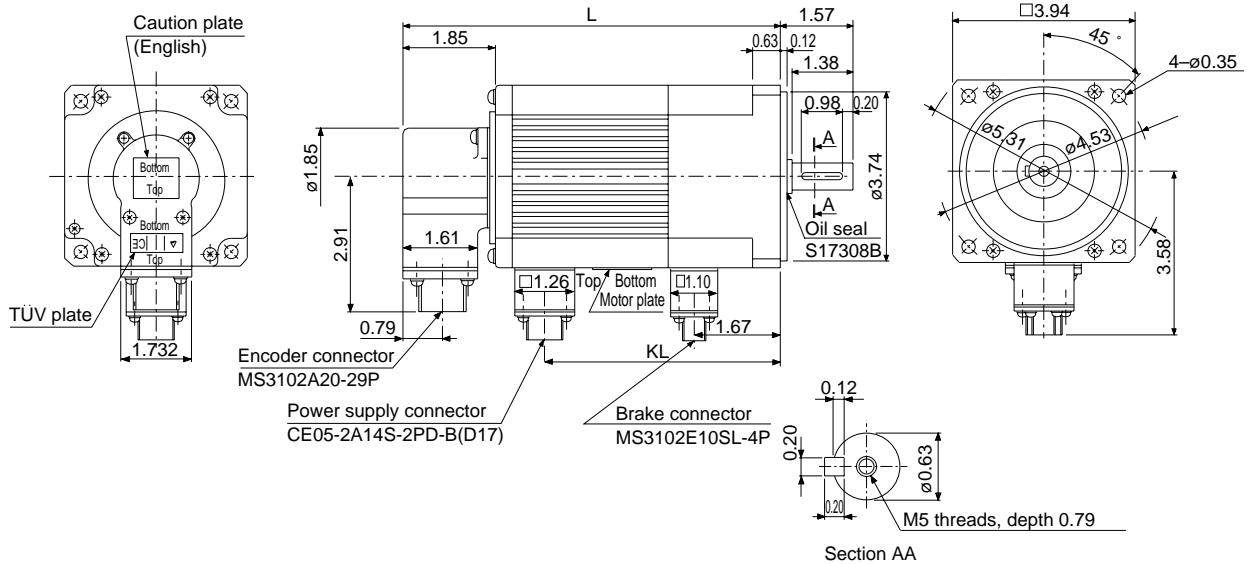


- Note: 1. For the pin-outs of the power supply and encoder connectors, refer to (3), Section 3-2-3.  
 2. For horizontal installation, it is recommended to face the power supply and encoder connectors down.

Model	Output [W]	Variable Dimensions		Braking Force [oz-in]	Inertia Moment WK <sup>2</sup> [oz-in <sup>2</sup> ]	Weight [lb]
		L	KL			
HA-FF23CB-UE	200	7.17	4.29	170	2.64	7.7
HA-FF33CB-UE	300	7.87	5.0		3.46	8.4

HA – FF43CB – UE • HA – FF63CB – UE

[Unit: in]



- Note: 1. For the pin-outs of the power supply and encoder connectors, refer to (3), Section 3-2-3.  
 2. For horizontal installation, it is recommended to face the power supply and encoder connectors down.

Model	Output [W]	Variable Dimensions		Braking Force [oz-in]	Inertia Moment WK <sup>2</sup> [oz-in <sup>2</sup> ]	Weight [lb]
		L	KL			
HA-FF43CB-UE	400	8.11	5.12	326	7.24	12.8
HA-FF63CB-UE	600	8.70	5.71		8.47	14.1

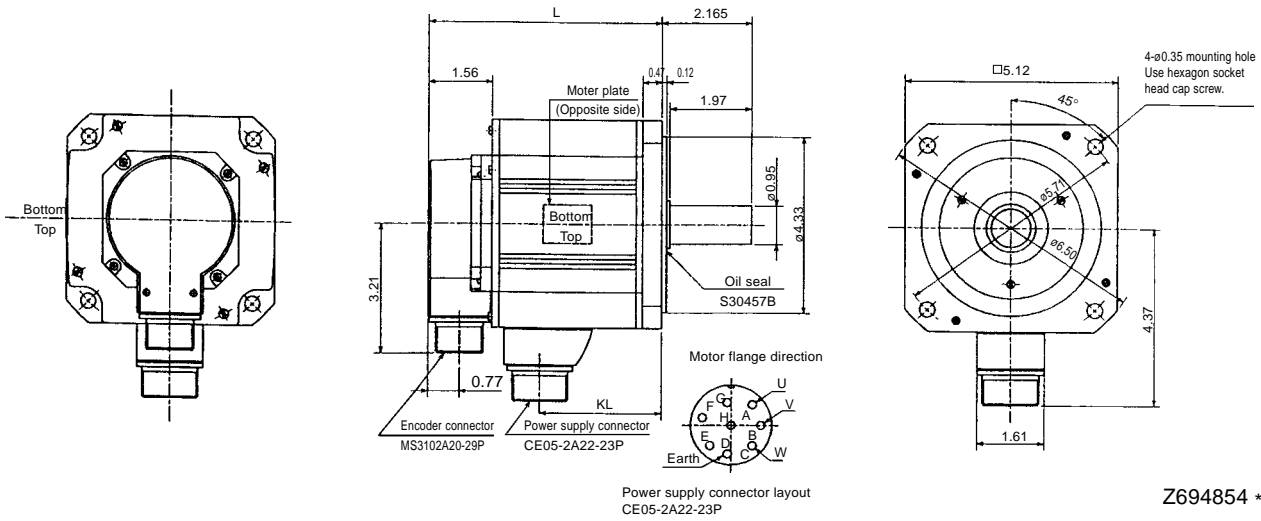
# 10. SPECIFICATIONS

## (5) HC-SF series

### 1) Standard (without electromagnetic brake, without reduction gear)

Model	Output (kW)	Variable Dimensions (in)		Inertia Moment $WK^2(oz\cdot in^2)$	Weight (lb)
		L	KL		
HC-SF52 HC-SF53	0.5	4.7	2.03	36.22	11.0
HC-SF102 HC-SF103	1.0	5.71	3.02	74.90	15.4
HC-SF81	0.85	6.69	4.00	109.08	19.8
HC-SF152 HC-SF153	1.5				

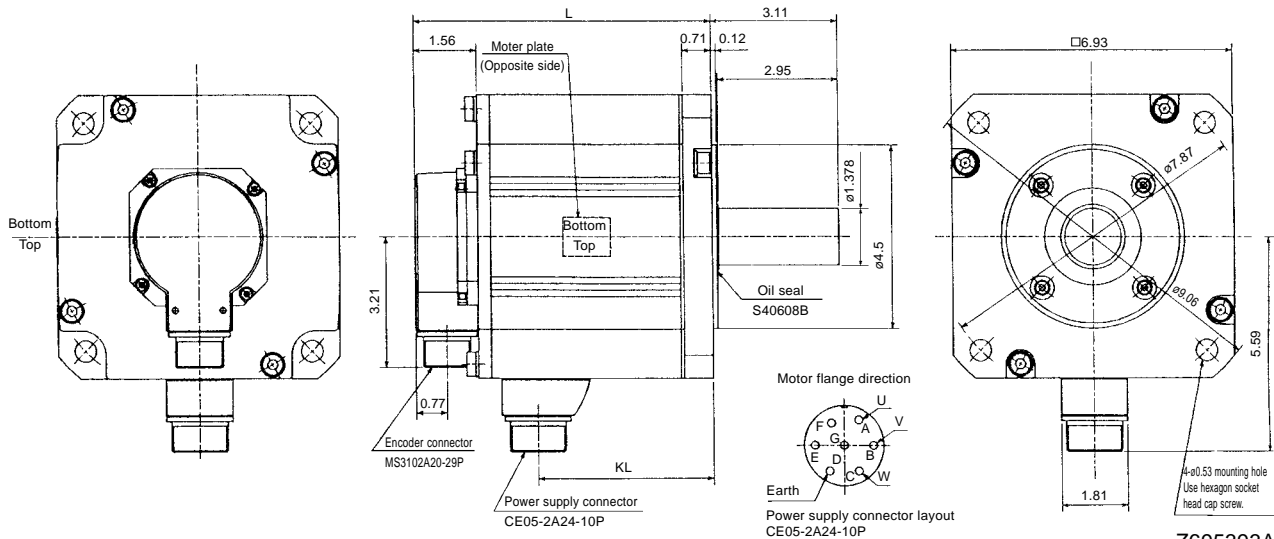
[Unit: in]



Z694854 \*

Model	Output (kW)	Variable Dimensions (in)		Inertia Moment $WK^2(oz\cdot in^2)$	Weight (lb)
		L	KL		
HC-SF121	1.2	5.71	2.70	232.37	26.5
HC-SF202 HC-SF203	2.0				
HC-SF201	2.0	7.36	4.35	448.33	41.9
HC-SF352 HC-SF353	3.5				

[Unit: in]

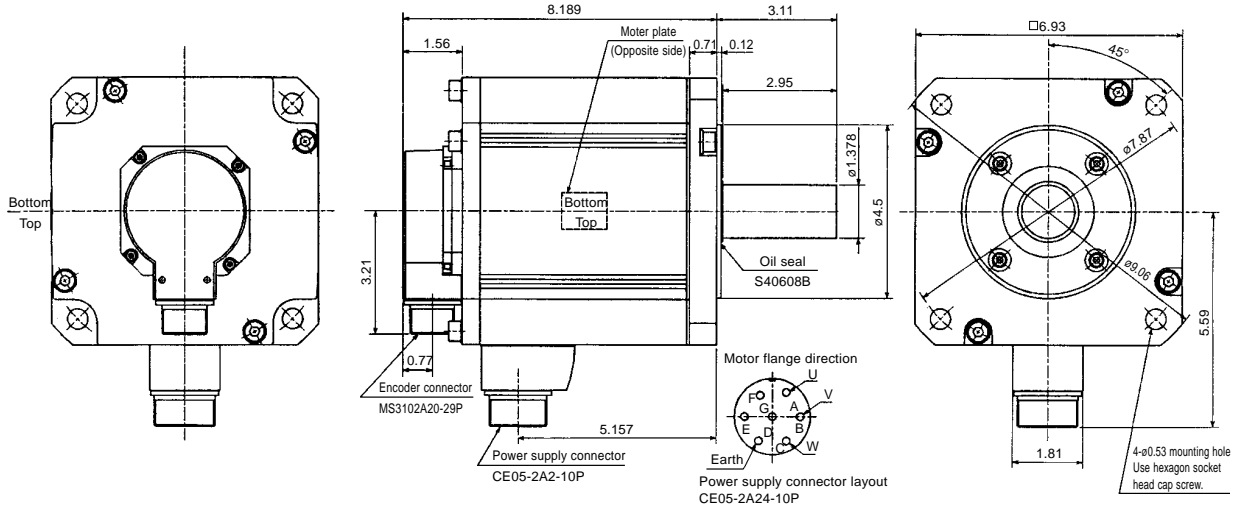


Z695393A

# 10. SPECIFICATIONS

Model	Output (kW)	Inertia Moment WK <sup>2</sup> (oz-in <sup>2</sup> )	Weight (lb)
HC-SF301	3.0	552.212	50.7

[Unit: in]

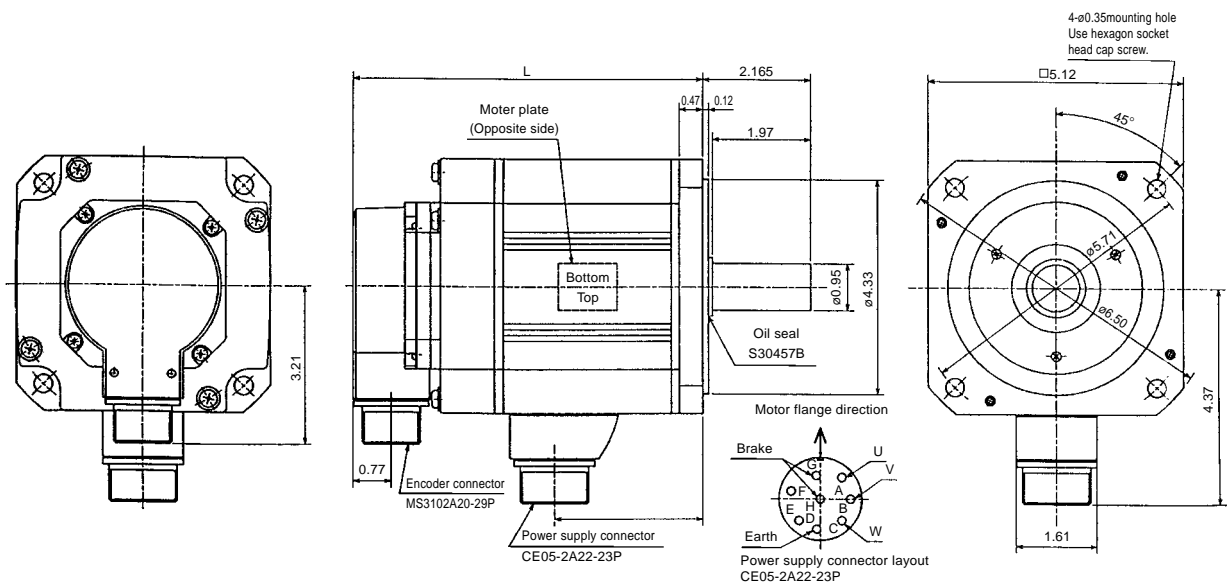


BC10628 \*

## 2) With electromagnetic brake

Model	Output (kW)	Variable Dimensions (in)		Braking Force (oz-in)	Inertia Moment WK <sup>2</sup> (oz-in <sup>2</sup> )	Weight (lb)
		L	KL			
HC-SF52B HC-SF53B	0.5	6.02	2.03	1204	45.52	16.535
HC-SF102B HC-SF103B	1.0	7.01	3.02	1204	84.20	20.944
HC-SF81B	0.85	7.99	4.00	1204	118.37	25.353
HC-SF152B HC-SF153B	1.5					

[Unit: in]

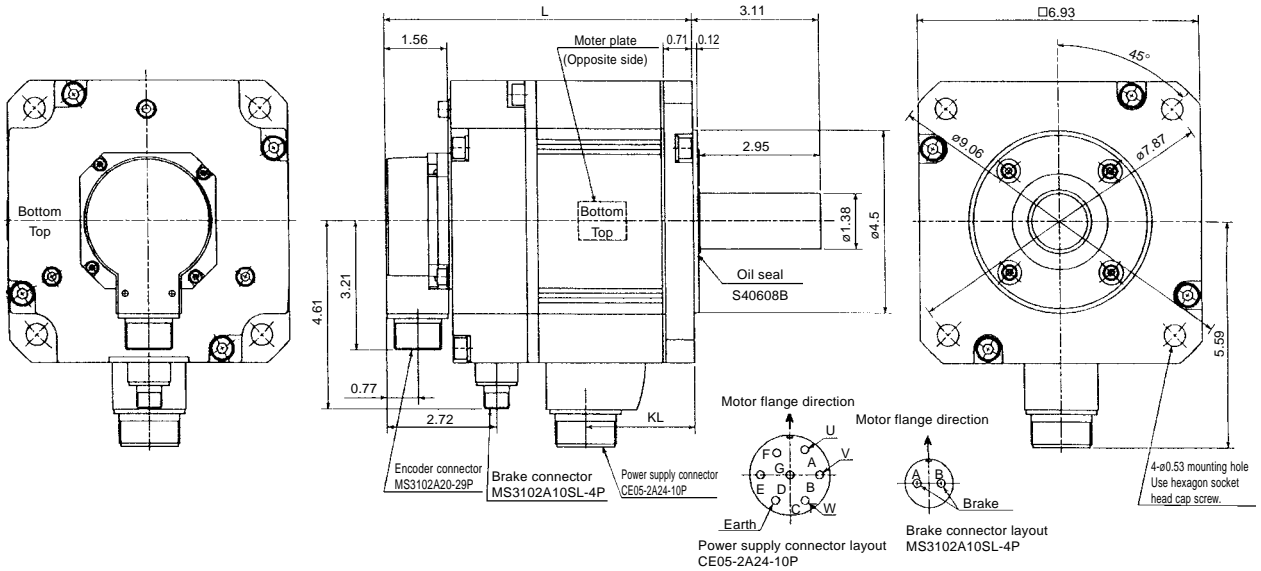


Z695005

# 10. SPECIFICATIONS

Model	Output (kW)	Variable Dimensions (in)		Braking Force (oz-in)	Inertia Moment $WK^2(oz-in^2)$	Weight (lb)
		L	KL			
HC-SF121B	1.2	7.60	2.70	6103	287.04	39.683
HC-SF202B HC-SF203B	2.0					
HC-SF201B	2.0	9.25	4.35	6103	503.01	55.115
HC-SF352B HC-SF253B	3.5					

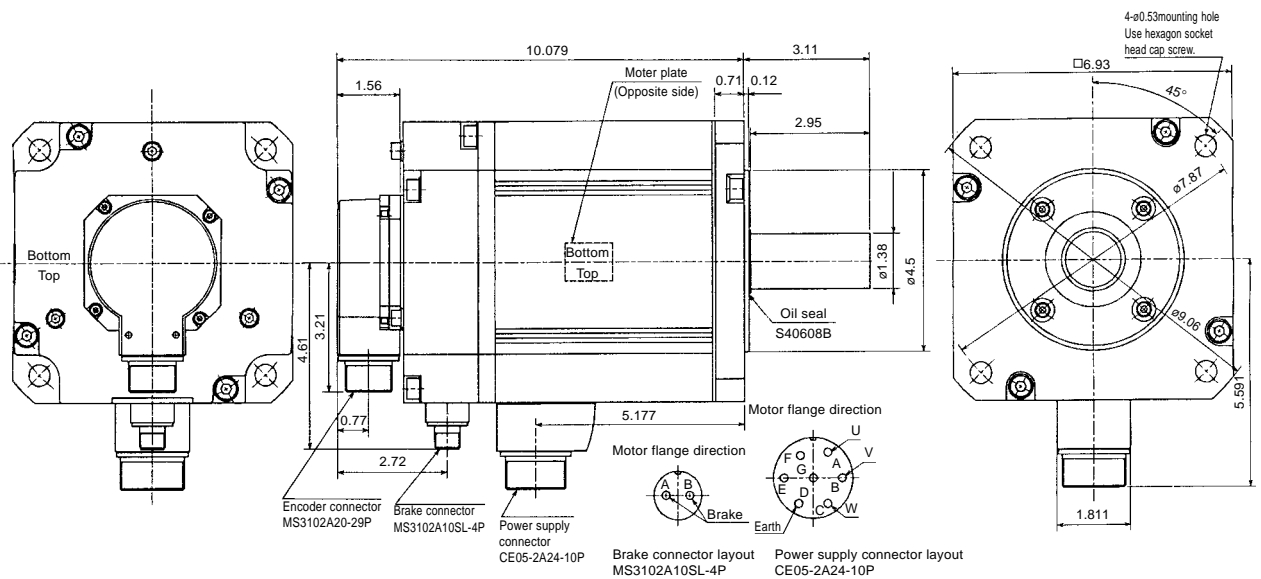
[Unit: in]



Z695319D

Model	Output (kW)	Braking Force (oz-in)	Inertia Moment $WK^2(oz-in^2)$	Weight (lb)
HC-SF301B	3.0	6103	606.886	63.9

[Unit: in]



BC10823 \*

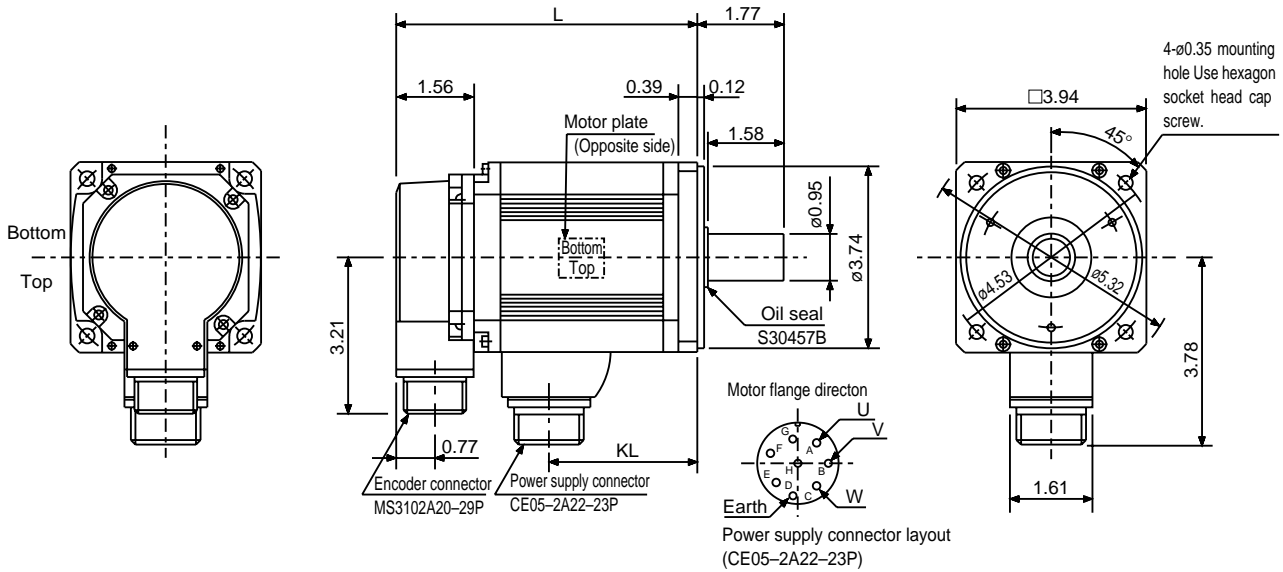


# 10. SPECIFICATIONS

## (6) HC-RF series

### 1) Standard (without electromagnetic brake, without reduction gear)

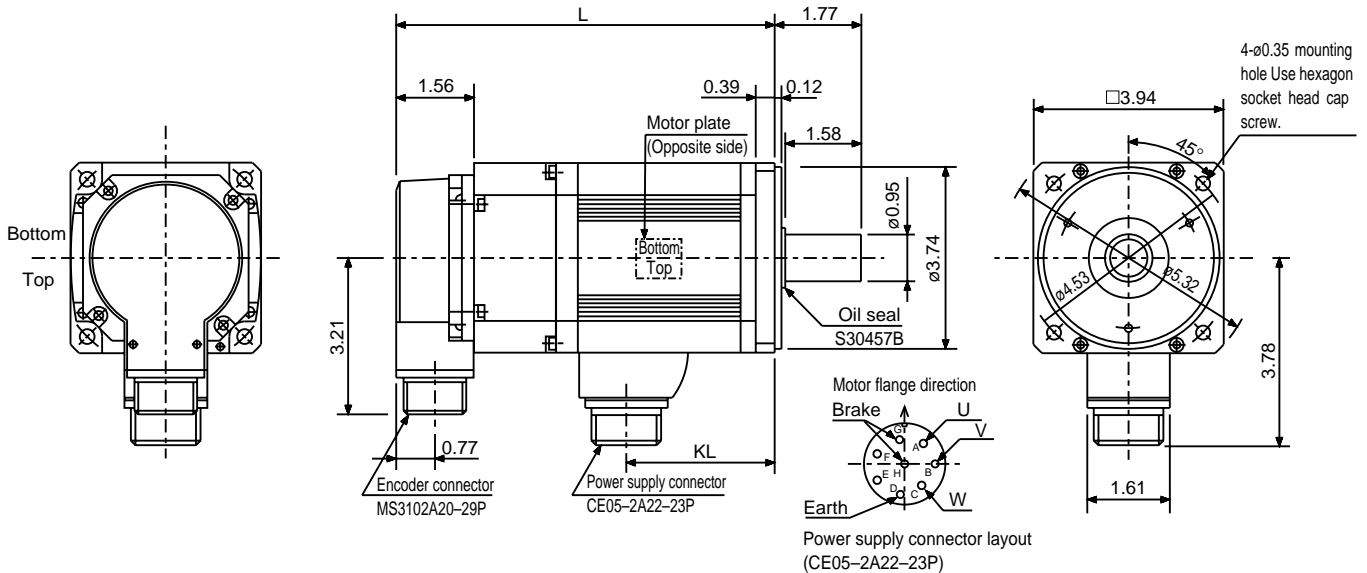
[Unit: in]



Model	Output (kW)	Variable Dimensions [in]		Inertia Moment WK <sup>2</sup> [oz•in <sup>2</sup> ]	Weight [lb]
		L	KL		
HC-RF103	1.0	5.79	2.80	8.20	8.6
HC-RF153	1.5	6.77	3.78	10.39	11.0
HC-RF203	2.0	7.76	4.76	12.58	13.7

### 2) Without electromagnetic brake

[Unit: in]



Model	Output (kW)	Variable Dimensions [in]		Barking Force [oz•in]	Inertia Moment WK <sup>2</sup> [oz•in <sup>2</sup> ]	Weight [lb]
		L	KL			
HC-RF103B	1.0	7.28	2.80	991	10.12	13.2
HC-RF153B	1.5	8.27	3.78	991	12.30	15.4
HC-RF203B	2.0	9.25	4.76	991	14.49	18.3

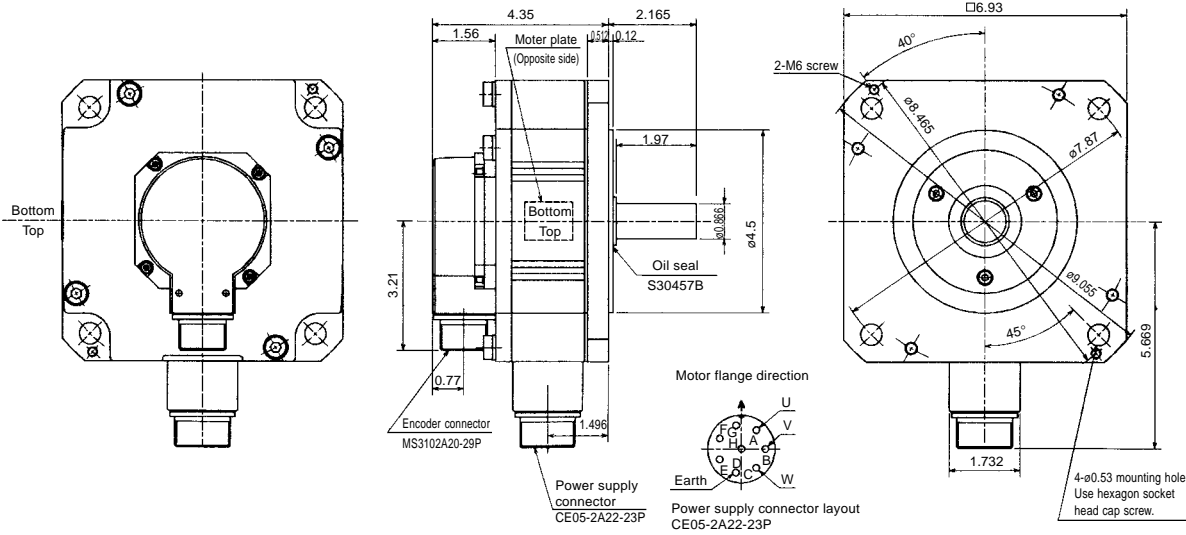
# 10. SPECIFICATIONS

## (7) HC-UF series

### 1) Standard (without electromagnetic brake)

Model	Output (kW)	Inertia Moment WK <sup>2</sup> (oz-in <sup>2</sup> )	Weight (lb)
HC-UF72	0.75	56.861	17.6

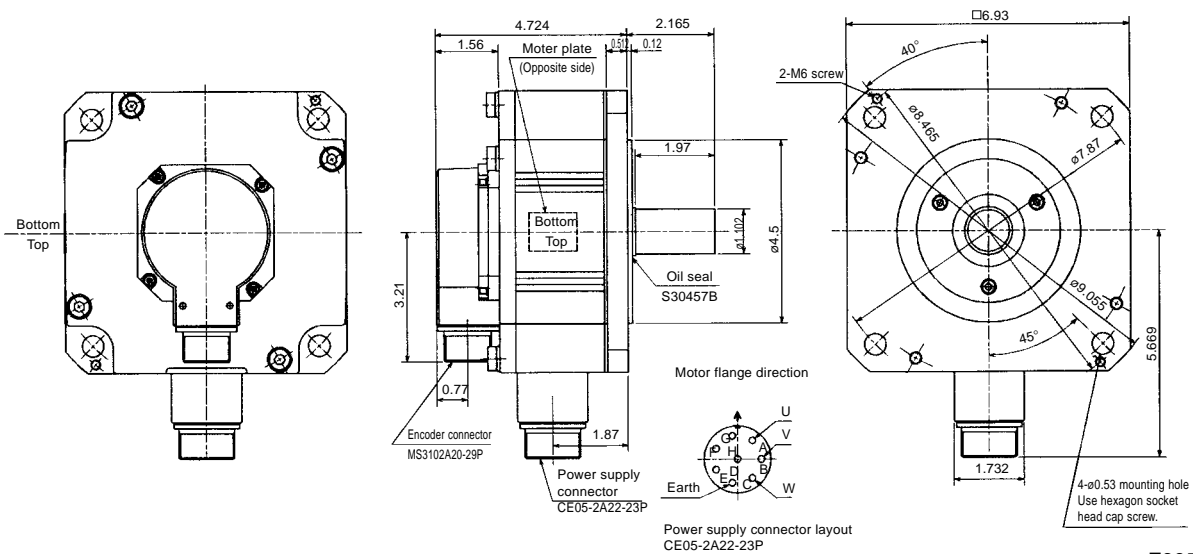
[Unit: in]



Z695911 \*

Model	Output (kW)	Inertia Moment WK <sup>2</sup> (oz-in <sup>2</sup> )	Weight (lb)
HC-UF152	1.5	120.831	24.3

[Unit: in]

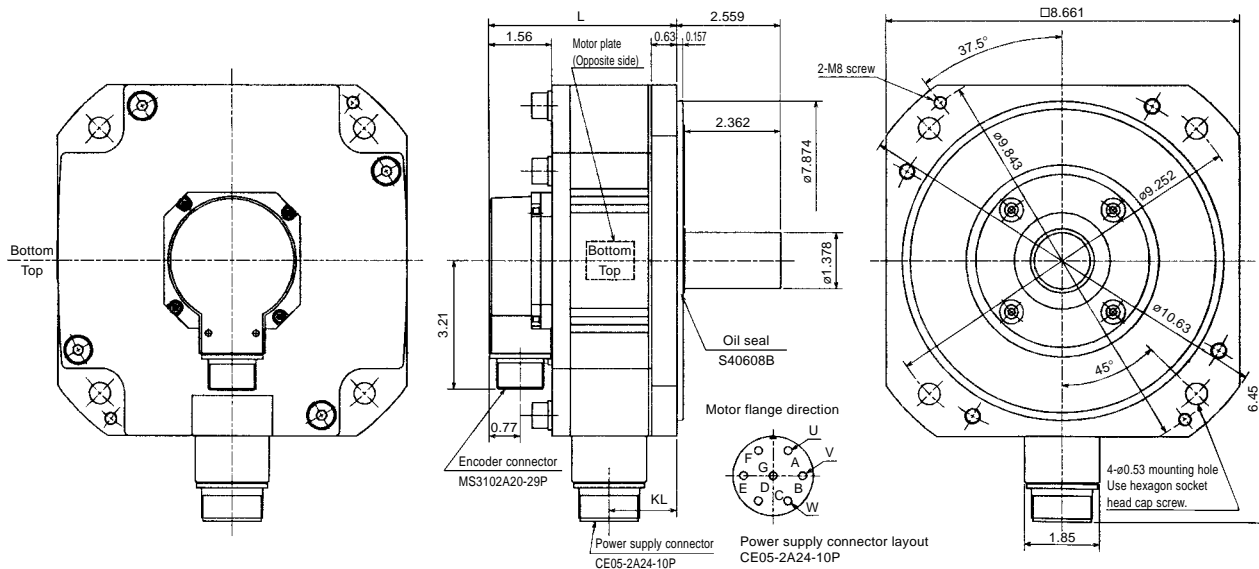


Z695912A

# 10. SPECIFICATIONS

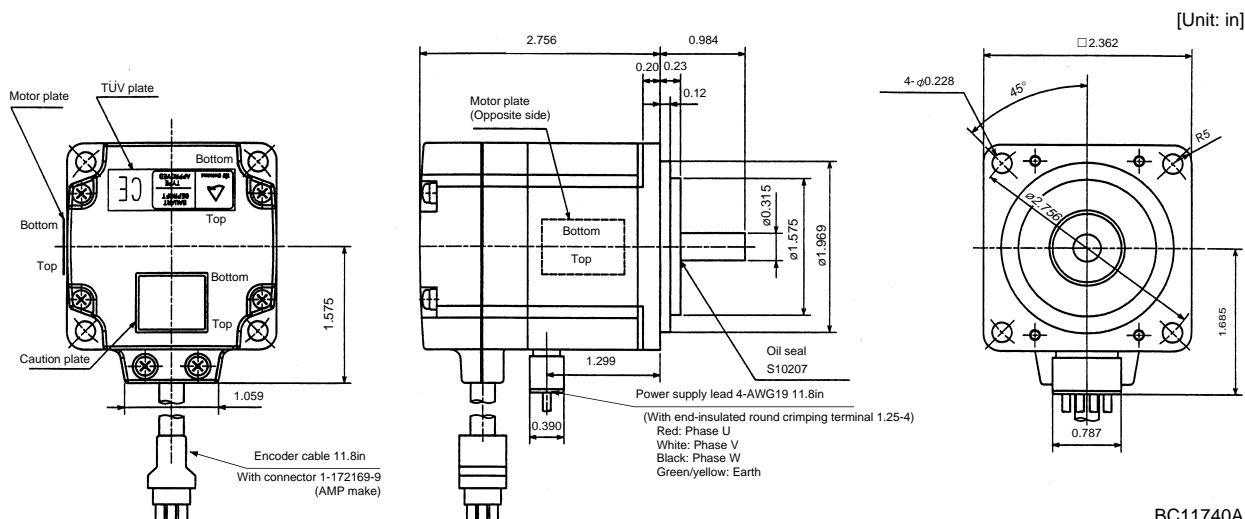
Model	Output (kW)	Variable Dimensions		Inertia Moment WK <sup>2</sup> (oz-in <sup>2</sup> )	Weight (lb)
		L	KL		
HC-UF202	2.0	4.646	1.673	208.856	35.3

[Unit: in]



Z695914 \*

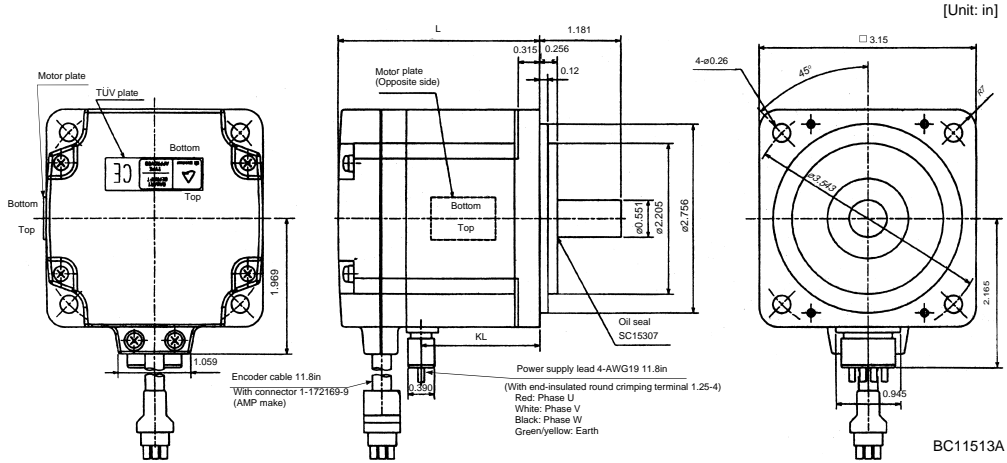
Model	Output (kW)	Inertia Moment WK <sup>2</sup> (oz-in <sup>2</sup> )	Weight (lb)
HC-UF13	100	0.361	1.8



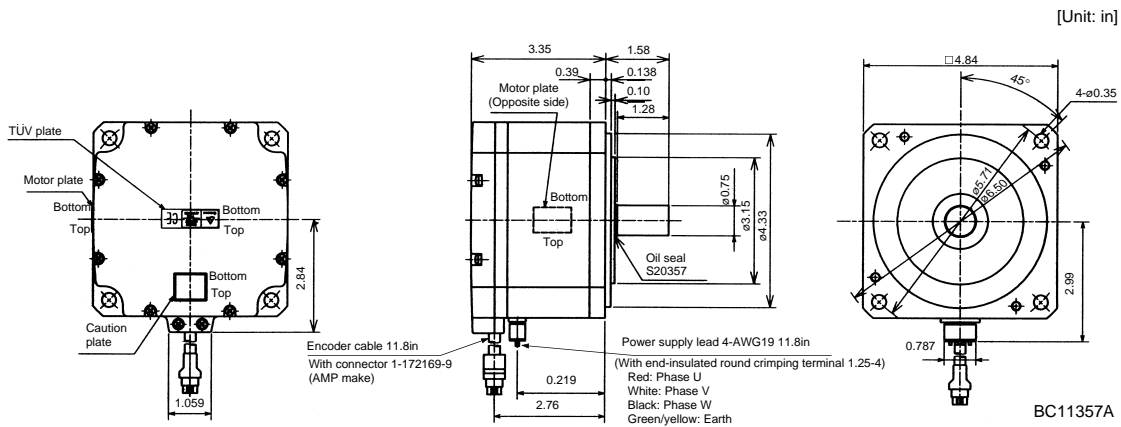
BC11740A

# 10. SPECIFICATIONS

Model	Output (W)	Variable Dimensions (in)		Inertia Moment $WK^2(oz\cdot in^2)$	Weight (lb)
		L	KL		
HC-UF23	200	2.953	1.724	1.318	3.3
HC-UF43	400	3.543	2.315	1.996	3.7

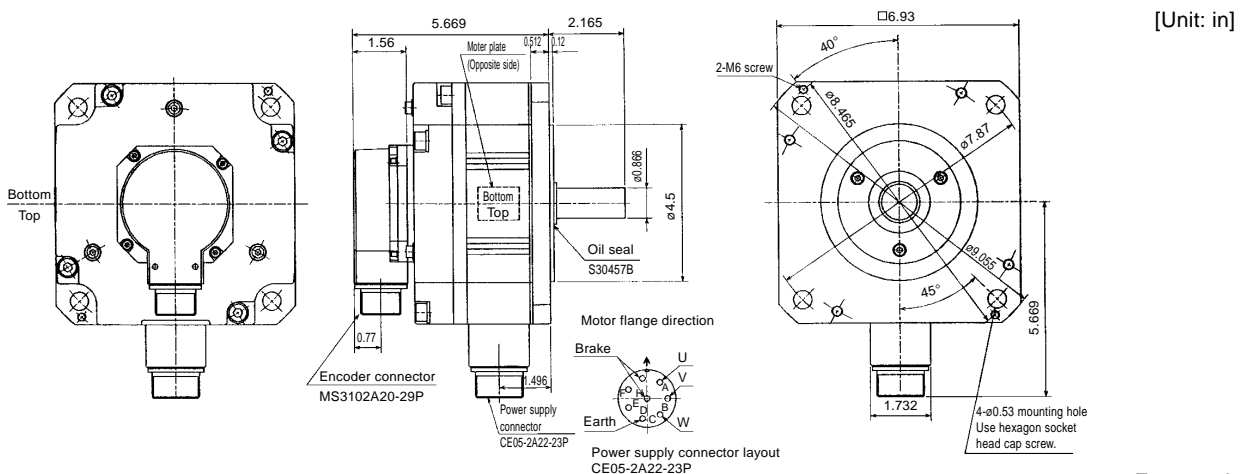


Model	Output (W)	Inertia Moment $WK^2(oz\cdot in^2)$	Weight (lb)
HC-UF73	750	32.258	11.0



## 2) With electromagnetic brake

Model	Output (kW)	Braking Force (oz-in)	Inertia Moment $WK^2(oz\cdot in^2)$	Weight (lb)
HC-UF72B	0.75	1204	67.796	22.0

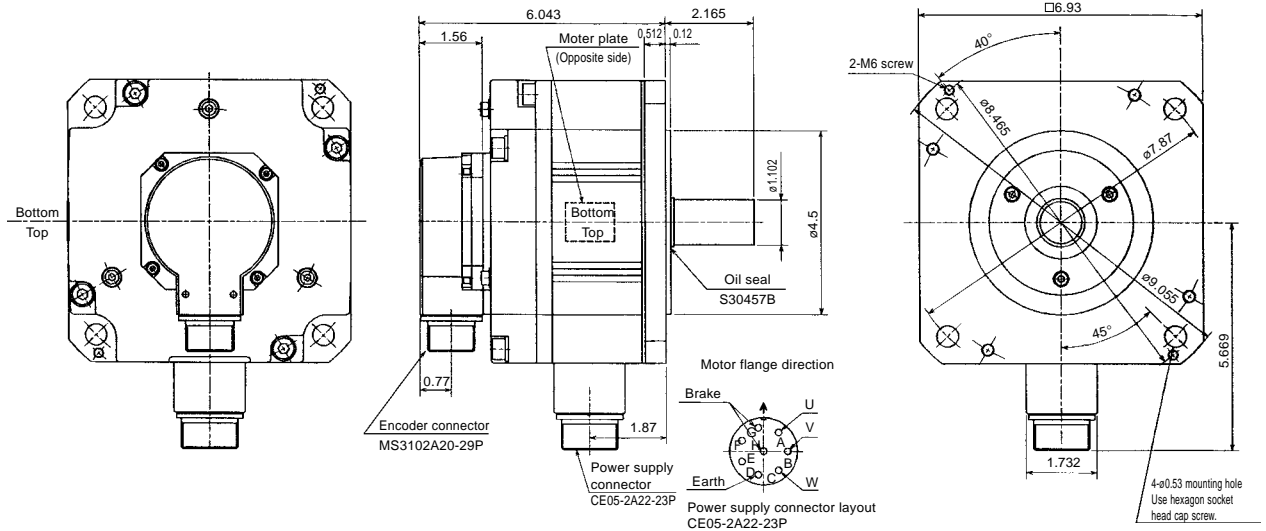


Z695981A

# 10. SPECIFICATIONS

Model	Output (kW)	Braking Force (oz-in)	Inertia Moment $WK^2$ (oz-in <sup>2</sup> )	Weight (lb)
HC-UF152B	1.5	1204	158.009	28.7

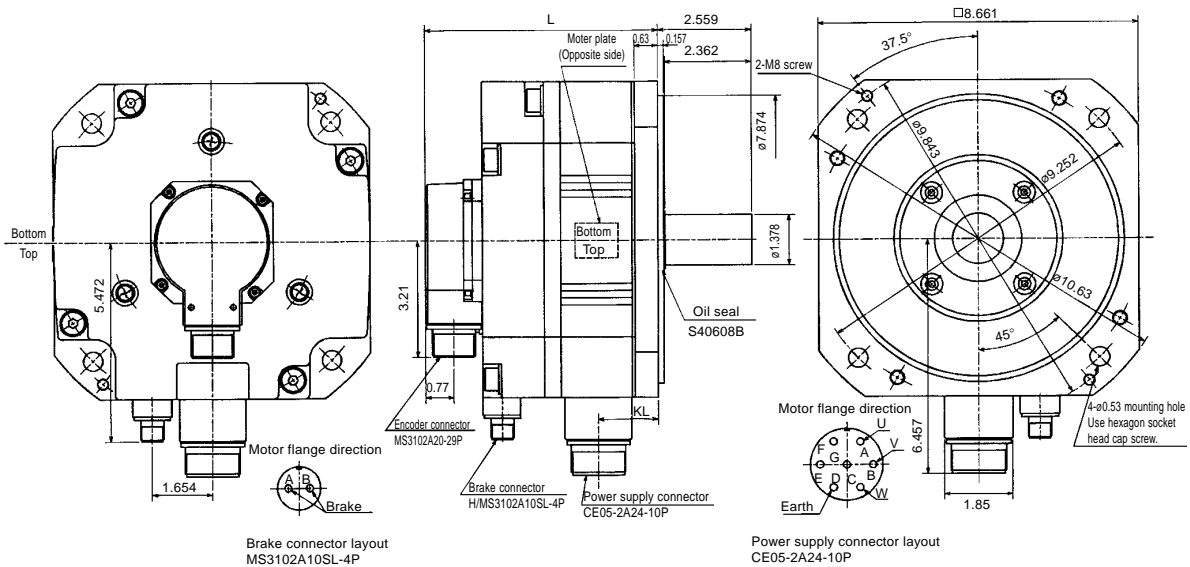
[Unit: in]



Z695982

Model	Output (kW)	Variable Dimensions (in)		Braking Force (oz-in)	Inertia Moment $WK^2$ (oz-in <sup>2</sup> )	Weight (lb)
		L	KL			
HC-UF202B	2.0	6.339	1.673	6103	255.876	48.5

[Unit: in]

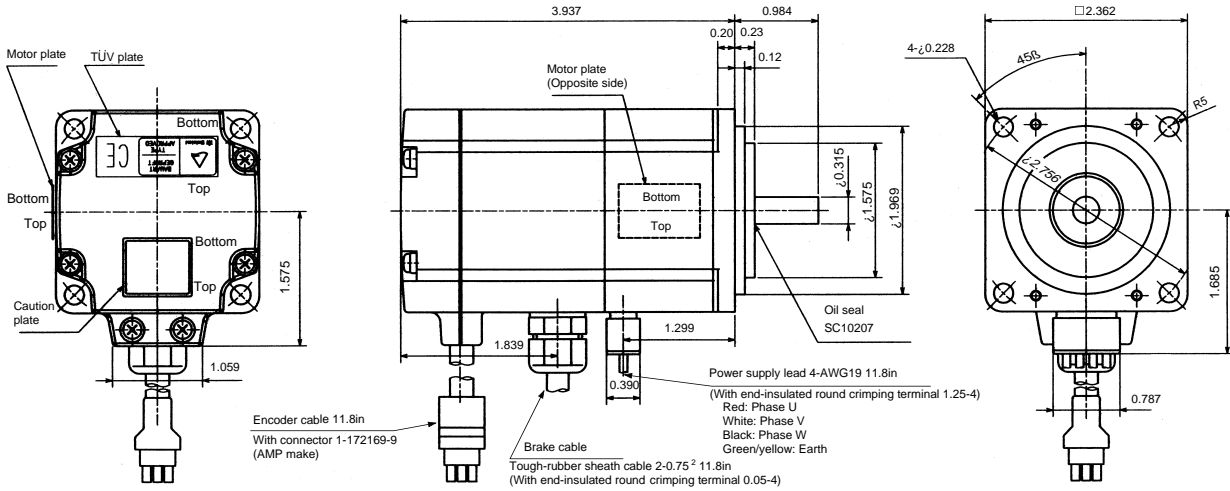


BC10647A

# 10. SPECIFICATIONS

Model	Output (kW)	Braking Force (oz-in)	Inertia Moment WK <sup>2</sup> (oz-in <sup>2</sup> )	Weight (lb)
HC-UF13B	100	45	0.405	2.6

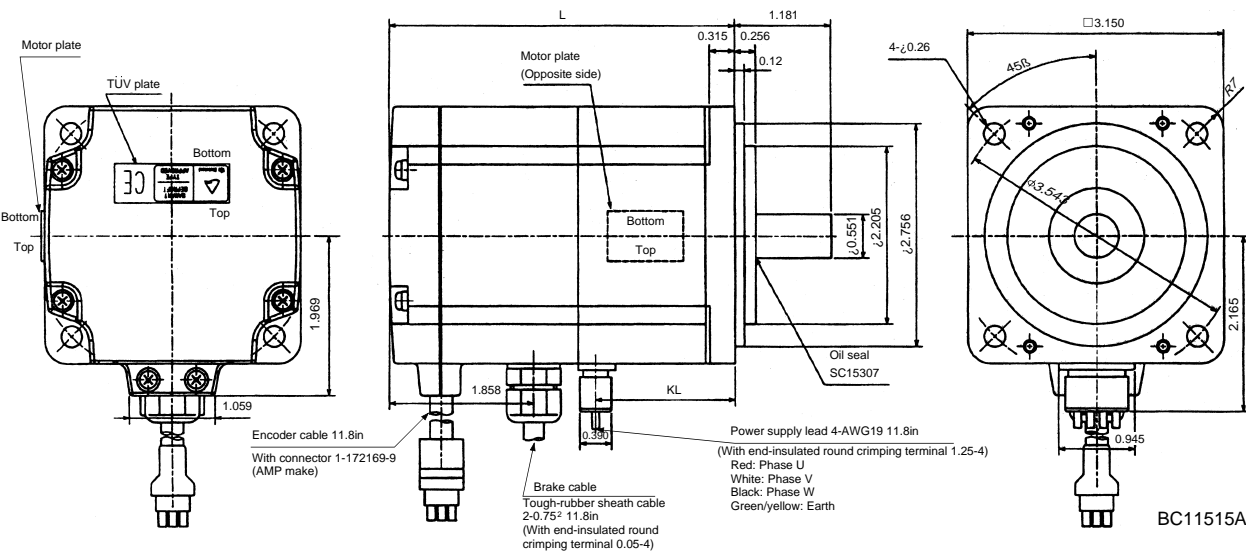
[Unit: in]



BC11767A

Model	Output (kW)	Variable Dimensions (in)		Braking Force (oz-in)	Inertia Moment WK <sup>2</sup> (oz-in <sup>2</sup> )	Weight (lb)
		L	KL			
HC-UF23B	200	4.291	1.724	184	1.766	4.9
HC-UF43B	400	4.882	2.315	184	2.444	5.3

[Unit: in]



BC11515A

# 10. SPECIFICATIONS

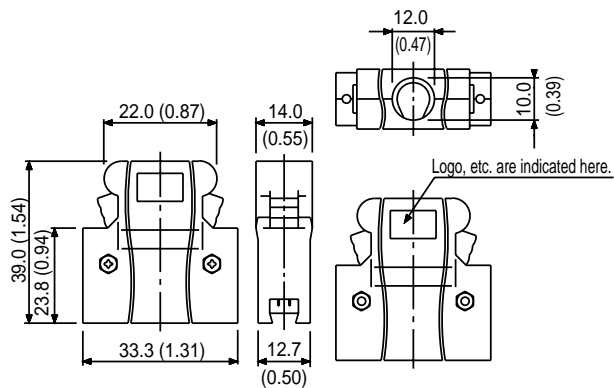
## 10-5-4 Cable side plugs

(1) Servo amplifier connector

Signal connector

<Sumitomo 3M make>

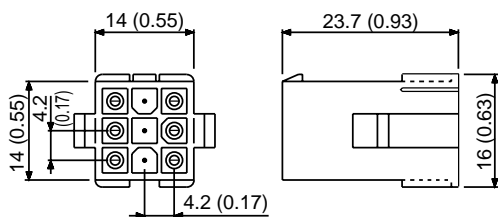
Model [Unit: mm]  
 Connector : 10120-3000VE ([Unit: in])  
 Shell kit : 10320-52F0-008



(2) HC- MF/HA-FF encoder junction connector

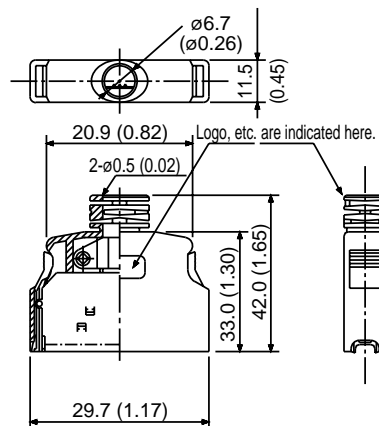
<Nippon AMP make>

Model [Unit: mm]  
 Housing : 1-172161-9 ([Unit: in])  
 Connector pin : 170359-1  
 Crimping tool : 755330-1



Model [Unit: mm]  
 Connector : 10120-6000EL ([Unit: in])  
 Shell kit : 10320-3210-000

**NOTICE** This connector is not optional.



**MEMORANDUM** The crimping tool is required for wiring to the connector. For the crimping tool, contact Nippon AMP.

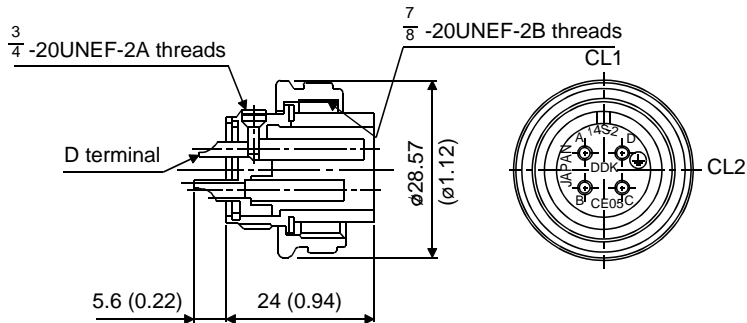
# 10. SPECIFICATIONS

## (3) Servo motor encoder side plugs

### (a) Connectors

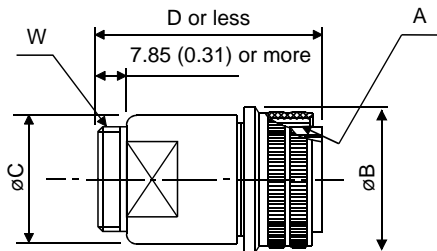
<Daiichi Denshi Kogyo make>

CE05-6A14S-2SD-B



[Unit: mm]

([Unit: in])



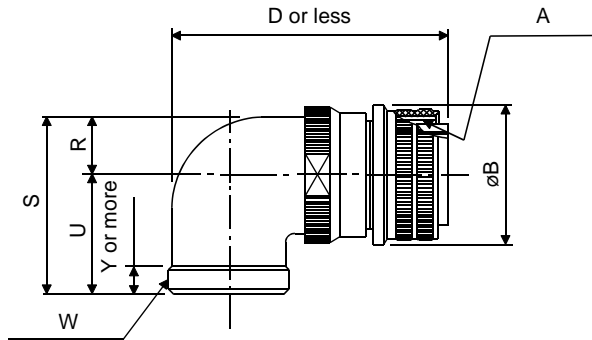
[Unit: mm]

([Unit: in])

Model	A	B	C	D	W
CE05-6A22-23SD-B-BSS	1 <sup>3</sup> / <sub>8</sub> -18UNEF-2B	40.48 (1.59)	38.3 (1.51)	61 (2.40)	1 <sup>3</sup> / <sub>16</sub> -18UNEF-2A
CE05-6A24-10SD-B-BSS	1 <sup>1</sup> / <sub>2</sub> -18UNEF-2B	43.63 (1.72)	42.0 (1.65)	68 (2.68)	1 <sup>7</sup> / <sub>16</sub> -18UNEF-2A
CE05-6A32-17SD-B-BSS	2-18UNS-2S	56.33 (2.22)	54.2 (2.13)	79 (3.11)	1 <sup>3</sup> / <sub>4</sub> -18UNS-2A

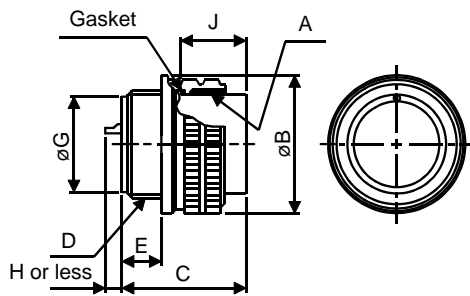


# 10. SPECIFICATIONS



[Unit: mm]  
([Unit: in])

Model	A	B	D	W	R	U	S	Y
CE05-8A22-23SD-B-BAS	1 <sup>3</sup> / <sub>8</sub> -18UNEF-2B	40.48 (1.59)	75.5 (2.97)	1 <sup>3</sup> / <sub>16</sub> -18UNEF-2A	16.3 (0.64)	33.3 (1.31)	49.6 (1.95)	7.5 (0.30)
CE05-8A24-10SD-B-BAS	1 <sup>1</sup> / <sub>2</sub> -18UNEF-2B	43.63 (1.72)	86.3 (3.40)	1 <sup>7</sup> / <sub>16</sub> -18UNEF-2A	18.2 (0.72)	36.5 (1.44)	54.7 (2.15)	7.5 (0.30)
CE05-8A32-17SD-B-BAS	2-18UNS-2B	56.33 (2.22)	93.5 (3.68)	1 <sup>3</sup> / <sub>4</sub> -18UNS-2A	24.6 (0.97)	44.5 (1.75)	61.9 (2.44)	8.5 (0.34)

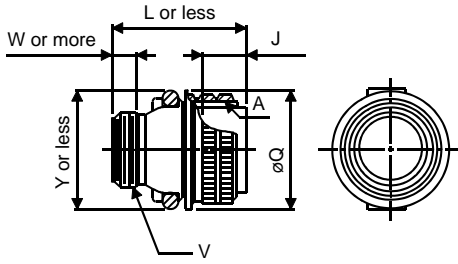


[Unit: mm]  
([Unit: in])

Model	A	B	C	D	E	G	J
MS3106A10SL-4S(D190)	5/ <sub>8</sub> -24UNEF-2B	22.22 (0.87)	23.3 (0.92)	9/ <sub>16</sub> -24UNEF-2A	7.5 (0.30)	12.5 (0.49)	13.49 (0.53)
MS3106A14S-2S(D190)	7/ <sub>8</sub> -20UNEF-2B	28.57 (1.13)	24.34 (0.96)	3/ <sub>4</sub> -20UNEF-2A	8.46 (0.33)	17.0 (0.67)	13.49 (0.53)
MS3106A20S-29S(D190)	1 <sup>1</sup> / <sub>4</sub> -18UNEF-2B	37.28 (1.47)	34.11 (1.34)	1 <sup>1</sup> / <sub>8</sub> -18UNEF-2A	12.16 (0.48)	26.8 (1.06)	18.26 (0.72)
MS3106A22S-23S(D190)	1 <sup>3</sup> / <sub>8</sub> -18UNEF-2B	40.48 (1.59)	34.11 (1.34)	1 <sup>1</sup> / <sub>4</sub> -18UNEF-2A	12.15 (0.48)	29.9 (1.18)	18.26 (0.72)
MS3106A24S-10S(D190)	1 <sup>1</sup> / <sub>2</sub> -18UNEF-2B	43.63 (1.72)	36.58 (1.44)	1 <sup>3</sup> / <sub>8</sub> -18UNEF-2A	13.42 (0.53)	32.9 (1.30)	18.26 (0.72)
MS3106A32S-17S(D190)	2-18UNS-2B	56.33 (2.22)	36.95 (1.46)	1 <sup>7</sup> / <sub>8</sub> -16UN-2A	13.14 (0.52)	45.3 (1.78)	18.26 (0.72)

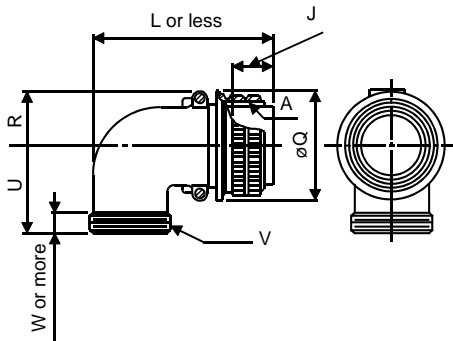
		Contact Size				
		#16	#12	#8	#4	#0
H	8 or less	8 or less	10 or less	13 or less	13 or less	

# 10. SPECIFICATIONS



[Unit: mm]  
([Unit: in])

Model	A	J	L	Q	V	W	Y
MS3106B14S-2S	7/8-20UNEF	13.49 (0.53)	42.88 (1.69)	28.57 (1.13)	3/4-20UNEF	8.0 (0.32)	30 (1.18)
MS3106B20-29S	1 1/4-18UNEF	18.26 (0.72)	55.57 (2.19)	37.28 (1.47)	1 3/16-18UNEF	9.53 (0.38)	47 (1.85)
MS3106B22-23S	1 3/8-18UNEF	18.26 (0.72)	55.57 (2.19)	40.48 (1.59)	1 3/16-18UNEF	9.53 (0.38)	50 (1.97)
MS3106B24-10S	1 3/2-8UNEF	18.26 (0.72)	58.72 (2.31)	43.63 (1.72)	1 7/16-18UNEF	9.53 (0.38)	53 (2.09)
MS3106B32-17S	2-18UNS	18.26 (0.72)	61.92 (2.44)	56.33 (2.22)	1 3/4-18UNS	11.13 (0.44)	66 (2.60)



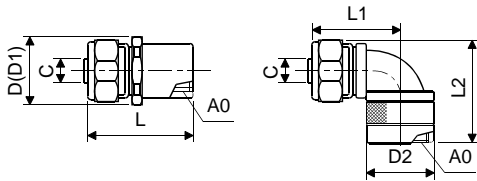
[Unit: mm]  
([Unit: in])

Model	A	J	L	Q	R	U	V	W
MS3106B14S-2S	7/8-20UNEF	13.49 (0.53)	53.97 (2.13)	28.57 (1.13)	14.9 (0.59)	27.0 (1.06)	3/4-20UNEF	9.53 (0.38)
MS3106B20-29S	1 1/4-18UNEF	18.26 (0.72)	79.68 (3.03)	37.28 (1.47)	22.5 (0.89)	33.3 (1.31)	1 3/16-18UNEF	9.53 (0.38)
MS3106B22-23S	1 3/8-18UNEF	18.26 (0.72)	76.98 (3.03)	40.48 (1.59)	24.1 (0.95)	33.3 (1.31)	1 3/16-18UNEF	9.53 (0.38)
MS3106B24-10S	1 3/2-8UNEF	18.26 (0.72)	86.51 (3.41)	43.63 (1.72)	25.6 (1.01)	36.5 (1.44)	1 7/16-18UNEF	9.53 (0.38)
MS3106B32-17S	2-18UNS	18.26 (0.72)	95.25 (3.75)	56.33 (2.22)	32.8 (1.29)	44.4 (1.75)	1 3/4-18UNS	11.13 (0.44)

## 2) Flexible conduit connectors <Daiwa Dengyo make>

MSA

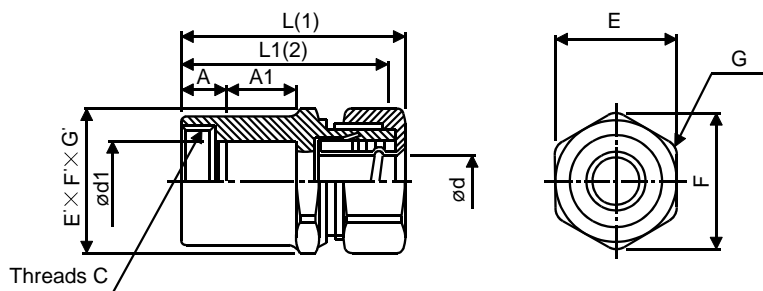
MAA



[Unit: mm]  
([Unit: in])

Model	A0	C	L	L <sub>1</sub>	L <sub>2</sub>	D	D <sub>1</sub>	D <sub>2</sub>
MSA10-10 • MAA10-10	9/16-24UNEF-2B	8.2 (0.32)	44 (1.73)	35.5 (1.40)	45 (1.77)	27 (1.06)	29 (1.14)	26 (1.02)
MSA10-14 • MAA10-14	3/4-20UNEF-2B	8.2 (0.32)	45 (1.77)	39.5 (1.56)	46 (1.18)	27 (1.06)	29 (1.14)	35 (1.38)
MSA12-14 • MAA12-14	3/4-20UNEF-2B	10.7 (0.42)	45 (1.77)	39.5 (1.56)	46 (1.18)	27 (1.06)	29 (1.14)	35 (1.38)
MSA16-20 • MAA16-20	1 1/8-18UNEF-2B	14 (0.55)	4.95 (1.95)	47 (1.85)	52 (2.05)	36 (1.42)	38 (1.50)	39 (1.54)
MSA16-22 • MAA16-22	1 1/4-18UNEF-2B	14 (0.55)	4.95 (1.95)	47 (1.85)	52 (2.05)	38 (1.50)	42 (1.65)	39 (1.54)
MSA16-24 • MAA16-24	1 3/8-18UNEF-2B	14 (0.55)	4.95 (1.95)	51 (2.01)	54 (2.13)	41 (1.61)	43 (1.69)	47 (1.85)
MSA22-20 • MAA22-20	1 1/8-18UNEF-2B	18.9 (0.74)	4.95 (1.95)	47 (1.85)	54 (2.13)	36 (1.42)	39 (1.54)	39 (1.54)
MSA22-22 • MAA22-22	1 1/4-18UNEF-2B	18.9 (0.74)	4.95 (1.95)	47 (1.85)	54 (2.13)	38 (1.50)	42 (1.65)	39 (1.54)
MSA22-24 • MAA22-24	1 3/8-18UNEF-2B	18.9 (0.74)	4.95 (1.95)	51 (2.01)	56 (2.21)	41 (1.61)	43 (1.69)	47 (1.85)
MSA28-22 • MAA28-22	1 1/4-18UNEF-2B	24.5 (0.97)	51 (2.01)	53 (2.09)	64 (2.52)	46 (1.18)	50 (1.97)	47 (1.85)
MSA28-24 • MAA28-24	1 3/8-18UNEF-2B	24.5 (0.97)	51 (2.01)	53 (2.09)	66 (2.60)	46 (1.18)	50 (1.97)	47 (1.85)

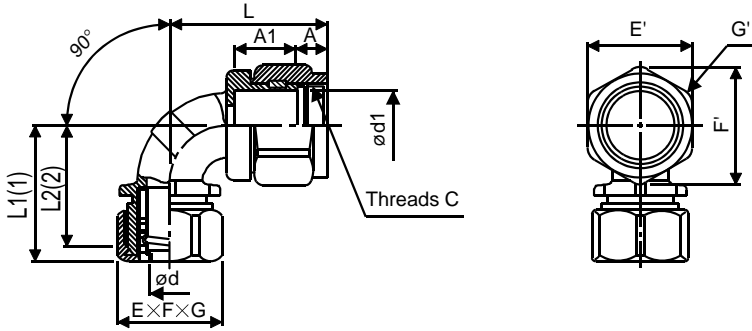
# 10. SPECIFICATIONS



[Unit: mm]  
([Unit: in])

Model	Threads C	A	A <sub>1</sub>	d	d <sub>1</sub>	Jam Nut			Lock Nut			L	L <sub>1</sub>
						E Width across flats	F Width across corners	G Number of corners	E' Width across flats	F' Width across corners	G' Number of corners		
RCC-102RL-MS10F	9/16-24UNEF-2B	6 (0.24)	15 (0.59)	8.3 (0.33)	11.0 (0.43)	24 (0.94)	26.4 (1.04)	6	24 (0.94)	26.4 (1.04)	6	39 (1.54)	36 (1.42)
RCC-102RL-MS14F	3/4-20UNEF-2B	7 (0.28)	15 (0.59)	8.3 (0.33)	15.0 (0.59)	24 (0.94)	26.4 (1.04)	6	24 (0.94)	26.4 (1.04)	6	40 (1.57)	37 (1.46)
RCC-103RL-MS14F	3/4-20UNEF-2B	7 (0.28)	15 (0.59)	10.6 (0.42)	15.0 (0.59)	27 (1.06)	29.7 (1.17)	6	26 (1.02)	28.6 (1.13)	6	44 (1.73)	41 (1.61)
RCC-104RL-MS14F	3/4-20UNEF-2B	7 (0.28)	15 (0.59)	14.0 (0.55)	15.0 (0.59)	30 (1.18)	33.0 (1.30)	6	30 (1.18)	33.0 (1.30)	6	45 (1.77)	42 (1.65)
RCC-104RL-MS20F	1-1/8-18UNEF-2B	9 (0.35)	15 (0.59)	14.0 (0.55)	24.0 (0.95)	30 (1.18)	33.0 (1.30)	6	32 (1.26)	35.2 (1.39)	6	47 (1.85)	44 (1.73)
RCC-104RL-MS22F	1-1/4-18UNEF-2B	9 (0.35)	15 (0.59)	14.0 (0.55)	27.0 (1.06)	30 (1.18)	33.0 (1.30)	6	36 (1.42)	39.6 (1.56)	6	47 (1.85)	44 (1.73)
RCC-104RL-MS24F	1-3/8-18UNEF-2B	10 (0.39)	20 (0.79)	14.0 (0.55)	30.0 (1.18)	30 (1.18)	33.0 (1.30)	6	40 (1.58)	42.5 (1.67)	6	54 (2.13)	50 (1.97)
RCC-106RL-MS20F	1-1/8-18UNEF-2B	9 (0.35)	15 (0.59)	19.0 (0.75)	24.0 (0.95)	37 (1.46)	40.7 (1.60)	6	36 (1.42)	39.6 (1.56)	6	50 (1.97)	46 (1.81)
RCC-106RL-MS22F	1-1/4-18UNEF-2B	9 (0.35)	15 (0.59)	19.0 (0.75)	27.0 (1.06)	37 (1.46)	40.7 (1.60)	6	36 (1.42)	39.6 (1.56)	6	50 (1.97)	46 (1.81)
RCC-106RL-MS24F	1-3/8-18UNEF-2B	10 (0.39)	20 (0.79)	19.0 (0.75)	30.0 (1.18)	37 (1.46)	40.7 (1.60)	6	40 (1.58)	42.5 (1.67)	8	56 (2.21)	52 (2.05)
RCC-106RL-MS32F	1-7/8-16UN-2B	11 (0.43)	20 (0.79)	19.0 (0.75)	42.5 (1.67)	37 (1.46)	40.7 (1.60)	6	52 (2.05)	54.5 (2.15)	8	57 (2.24)	53 (2.09)
RCC-108RL-MS22F	1-1/4-18UNEF-2B	9 (0.35)	15 (0.59)	24.4 (0.96)	27.0 (1.06)	45 (1.77)	47.3 (1.86)	8	44 (1.73)	46.3 (1.82)	8	55 (2.17)	50 (1.97)
RCC-108RL-MS24F	1-3/8-18UNEF-2B	10 (0.39)	20 (0.79)	24.4 (0.96)	30.0 (1.18)	45 (1.77)	47.3 (1.86)	8	44 (1.73)	46.3 (1.82)	8	60 (2.36)	55 (2.17)
RCC-108RL-MS32F	1-7/8-16UN-2B	11 (0.43)	20 (0.79)	24.4 (0.96)	42.5 (1.67)	45 (1.77)	47.3 (1.86)	8	52 (2.05)	54.5 (2.15)	8	61 (2.40)	56 (2.21)

# 10. SPECIFICATIONS

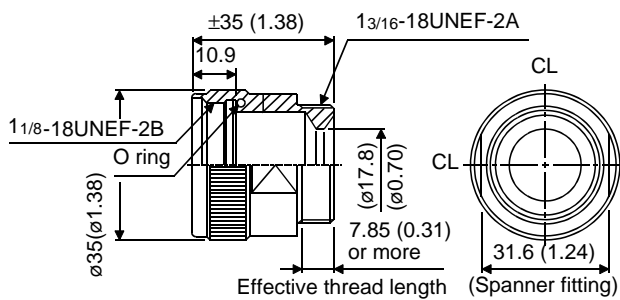


[Unit: mm]  
 ([Unit: in])

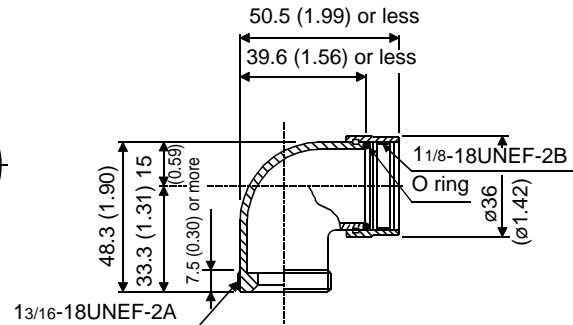
Model	Threads C	A	A <sub>1</sub>	d	d <sub>1</sub>	Jam Nut			Lock Nut			L	L <sub>1</sub>	L <sub>1</sub>
						E Width across flats	F Width across corners	G Number of corners	E' Width across flats	F' Width across corners	G' Number of corners			
RCC-302RL-MS10F	9/16-24UNEF-2B	6 (0.24)	15 (0.59)	8.3 (0.33)	10.0 (0.39)	24 (0.94)	26.4 (1.04)	6	20 (0.79)	22.0 (0.87)	6	35 (1.38)	33 (1.30)	30 (1.18)
RCC-302RL-MS14F	3/4-20UNEF-2B	7 (0.28)	15 (0.59)	8.3 (0.33)	13.8 (0.54)	24 (0.94)	26.4 (1.04)	6	23 (0.91)	25.3 (1.0)	6	35 (1.38)	33 (1.30)	30 (1.18)
RCC-303RL-MS14F	3/4-20UNEF-2B	7 (0.28)	15 (0.59)	10.6 (0.42)	13.8 (0.54)	27 (1.06)	29.7 (1.17)	6	23 (0.91)	25.3 (1.0)	6	37 (1.46)	37 (1.46)	34 (1.34)
RCC-304RL-MS14F	3/4-20UNEF-2B	7 (0.28)	15 (0.59)	14.0 (0.55)	13.8 (0.54)	30 (1.18)	33.0 (1.30)	6	23 (0.91)	25.3 (1.0)	6	39 (1.54)	38 (1.50)	35 (1.38)
RCC-304RL-MS20F	1-1/8-18UNEF-2B	9 (0.35)	15 (0.59)	14.0 (0.55)	23.2 (0.91)	30 (1.18)	33.0 (1.30)	6	32 (1.26)	35.2 (1.39)	6	41 (1.61)	38 (1.50)	35 (1.38)
RCC-304RL-MS22F	1-1/4-18UNEF-2B	9 (0.35)	15 (0.59)	14.0 (0.55)	26.5 (1.04)	30 (1.18)	33.0 (1.30)	6	36 (1.42)	39.6 (1.56)	6	41 (1.61)	38 (1.50)	35 (1.38)
RCC-304RL-MS24F	1-3/8-18UNEF-2B	10 (0.39)	20 (0.79)	14.0 (0.55)	28.7 (1.13)	30 (1.18)	33.0 (1.30)	6	40 (1.58)	42.5 (1.67)	8	47 (1.85)	46 (1.81)	43 (1.69)
RCC-306RL-MS20F	1-1/8-18UNEF-2B	9 (0.35)	15 (0.59)	19.0 (0.75)	23.2 (0.91)	37 (1.46)	40.7 (1.60)	6	32 (1.26)	35.2 (1.39)	6	45 (1.77)	44 (1.73)	40 (1.58)
RCC-306RL-MS22F	1-1/4-18UNEF-2B	9 (0.35)	15 (0.59)	19.0 (0.75)	26.5 (1.04)	37 (1.46)	40.7 (1.60)	6	36 (1.42)	39.6 (1.56)	6	45 (1.77)	44 (1.73)	40 (1.58)
RCC-306RL-MS24F	1-3/8-18UNEF-2B	10 (0.39)	20 (0.79)	19.0 (0.75)	28.7 (1.13)	37 (1.46)	40.7 (1.60)	6	40 (1.58)	42.5 (1.67)	8	51 (2.01)	49 (1.93)	45 (1.77)
RCC-306RL-MS32F	1-7/8-16UN-2B	11 (0.43)	20 (0.79)	19.0 (0.75)	40.6 (1.60)	37 (1.46)	40.7 (1.60)	6	54 (2.13)	56.7 (2.23)	8	52 (2.05)	49 (1.93)	45 (1.77)
RCC-308RL-MS22F	1-1/4-18UNEF-2B	9 (0.35)	15 (0.59)	24.4 (0.96)	26.5 (1.04)	45 (1.77)	47.3 (1.86)	8	36 (1.42)	39.6 (1.56)	6	49 (1.93)	50 (1.97)	45 (1.77)
RCC-308RL-MS24F	1-3/8-18UNEF-2B	10 (0.39)	20 (0.79)	24.4 (0.96)	28.7 (1.13)	45 (1.77)	47.3 (1.86)	8	40 (1.58)	42.5 (1.67)	8	56 (2.21)	50 (1.97)	45 (1.77)
RCC-308RL-MS32F	1-7/8-16UN-2B	11 (0.43)	20 (0.79)	24.4 (0.96)	40.6 (1.60)	45 (1.77)	47.3 (1.86)	8	54 (2.13)	56.7 (2.23)	8	62 (2.44)	50 (1.97)	45 (1.77)

### 3) Back shell <Daiichi Denshi Kogyo make>

CE02-20BS-S

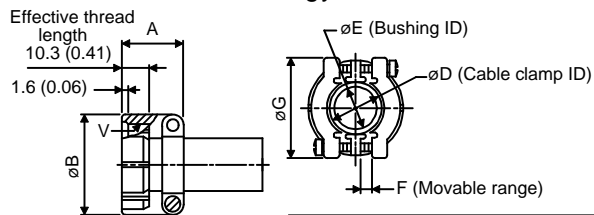


CE-20BA-S



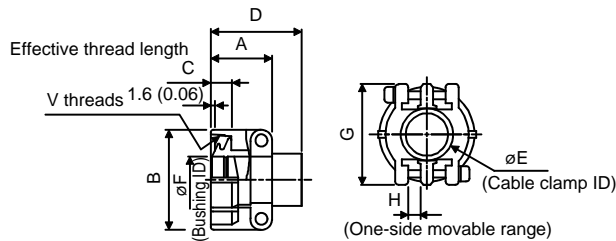
# 10. SPECIFICATIONS

## 4) Cable clamps <Daiichi Denshi Kogyo make>



[Unit: mm]  
([Unit: in])

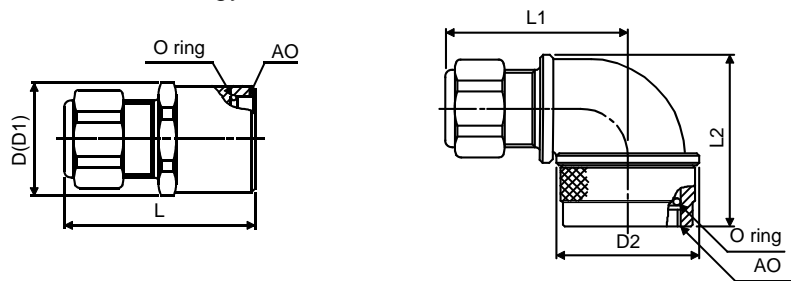
Model	Shell Size	A	B	C	D	E	F	G	V	Bushing
MS3057-6A	14S	22.2 (0.87)	24.6 (0.97)	10.3 (0.41)	11.2 (0.44)	7.9 (0.31)	2.0 (0.08)	27.0 (1.06)	3/4-20UNEF	AN3420-6
MS3057-12A	20, 22	23.8 (0.94)	35.0 (1.38)	10.3 (0.41)	19.0 (0.75)	15.9 (0.63)	4.0 (0.16)	37.8 (1.47)	13/16-18UNEF	AN3420-12
MS3057-16A	24, 28	26.2 (1.03)	42.1 (1.66)	10.3 (0.41)	23.8 (0.94)	15.9 (0.63) 19.1 (0.75)	4.8 (0.19)	42.9 (1.69)	17/16-18UNEF	AN3420-12 AN3420-16
MS3057-16A	32	27.8 (1.09)	51.6 (2.03)	11.9 (0.47)	31.7 (1.25)	19.1 (0.75) 23.8 (0.94)	6.3 (0.25)	51.6 (2.03)	13/4-18UNS	AN3420-16 AN3420-20



[Unit: mm]  
([Unit: in])

Model	Shell Size	A	B	C	D	E	F	G	H	V	Bushing	Cable Range
CE3057-12A-1	20	23.8 (0.94)	35.0 (1.38)	10.3 (0.41)	41.3 (1.63)	19.0 (0.75)	16 (0.63)	37.3 (1.47)	4 (0.16)	13/16-18UNEF-2B	CE3420-12-1	ø12.5 to ø16
CE3057-12A-2							13 (0.51)				CE3420-12-2	ø9.5 to ø13
CE3057-12A-3							10 (0.39)				CE3420-12-3	ø6.8 to ø10
CE3057-16A-1	24	26.2 (1.03)	42.1 (1.66)	10.3 (0.41)	41.3 (1.63)	23.8 (0.94)	19.1 (0.75)	42.9 (1.69)	4.8 (0.19)	17/16-18UNEF-2B	CE3420-16-1	ø15 to ø19.1
CE3057-16A-2							15.5 (0.61)				CE3420-16-2	ø13 to ø15.5
CE3057-20A-2	32	27.8 (1.09)	51.6 (2.03)	11.9 (0.47)	43 (1.69)	31.7 (1.25)	23.8 (0.94)	51.6 (2.03)	6.3 (0.25)	13/4-18UNS-2B	CE3420-20-1	ø22 to ø23.8

## <Daiwa Densyo make>

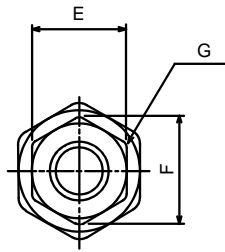
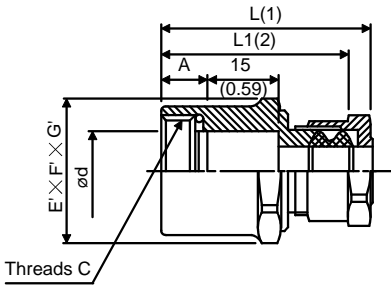


[Unit: mm]  
([Unit: in])

Model	Acceptable OD	AO	L	L <sub>1</sub>	L <sub>2</sub>	D	D <sub>1</sub>	D <sub>2</sub>
YSO10-5 to 8 • YLO10-5 to 8	ø5 to 8.3 (ø0.20 to 0.33)	9/16-24UNEF-2B	43 (1.69)	39 (1.54)	42.5 (1.67)	24 (0.94)	26 (1.02)	26 (1.02)
YSO14-5 to 8 • YLO14-5 to 8	ø5 to 8.3 (ø0.20 to 0.33)	3/4-20UNEF-2B	44 (1.73)	43.5 (1.71)	44.5 (1.75)	26 (1.02)	28 (1.10)	35 (1.38)
YSO14-9 to 11 • YLO14-9 to 11	ø8.3 to 11.3 (ø0.33 to 0.45)							

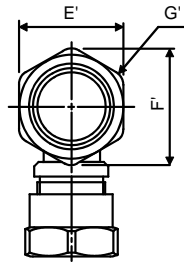
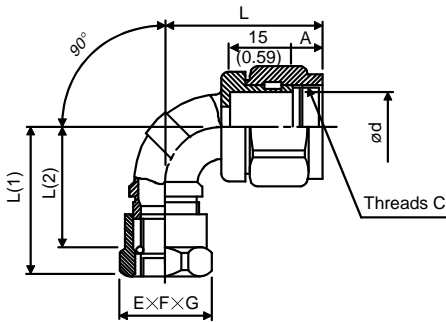
# 10. SPECIFICATIONS

<Nippon Flex make>



[Unit: mm]  
([Unit: in])

Model	Threads C	Applicable Cable Diameter	A	d	Tightening Nut			Nipple Body			L	L <sub>1</sub>
					E Width across flats	F Width across corners	G Number of corners	E' Width across flats	F' Width across corners	G' Number of corners		
ACS-08RL-MS10F	9/16-24UNEF-2B	ø4.0 to ø8.0 (ø0.16 to 0.32)	6 (0.24)	11.0 (0.43)	20 (0.79)	22.0 (0.87)	6	20 (0.79)	22.0 (0.87)	6	45 (1.77)	40 (1.57)
ACS-08RL-MS14F	3/4-20UNEF-2B	ø4.0 to ø8.0 (ø0.16 to 0.32)	7 (0.28)	15.0 (0.59)	20 (0.79)	22.0 (0.87)	6	22 (0.87)	24.2 (0.95)	6	46 (1.81)	41 (1.61)
ACS-12RL-MS10F	9/16-20UNEF-2B	ø8.0 to ø12.0 (ø0.32 to 0.47)	6 (0.24)	11.0 (0.43)	24 (0.94)	26.4 (1.04)	6	24 (0.94)	26.4 (1.04)	6	46 (1.81)	41 (1.61)
ACS-12RL-MS14F	3/4-20UNEF-2B	ø8.0 to ø12.0 (ø0.32 to 0.47)	7 (0.28)	15.0 (0.59)	24 (0.94)	26.4 (1.04)	6	36 (1.42)	28.6 (1.13)	6	46 (1.81)	41 (1.61)



[Unit: mm]  
([Unit: in])

Model	Threads C	Applicable Cable Diameter	A	d	Tightening Nut			Lock Nut			L	L <sub>1</sub>	L <sub>2</sub>
					E Width across flats	F Width across corners	G Number of corners	E' Width across flats	F' Width across corners	G' Number of corners			
ACA-08RL-MS10F	9/16-24UNEF-2B	ø4.0 to ø8.0 (ø0.16 to 0.32)	6 (0.24)	10.0 (0.39)	20 (0.79)	22.0 (0.87)	6	20 (0.79)	22.0 (0.87)	6	35 (1.38)	37 (1.46)	32 (1.26)
ACA-08RL-MS14F	3/4-20UNEF-2B	ø4.0 to ø8.0 (ø0.16 to 0.32)	7 (0.28)	13.8 (0.54)	20 (0.79)	22.0 (0.87)	6	23 (0.91)	25.3 (1.00)	6	36 (1.42)	37 (1.46)	32 (1.26)
ACA-12RL-MS10F	9/16-20UNEF-2B	ø8.0 to ø12.0 (ø0.32 to 0.47)	6 (0.24)	10.0 (0.39)	24 (0.94)	26.4 (1.04)	6	20 (0.79)	22.0 (0.87)	6	40 (1.57)	43 (1.69)	38 (1.50)
ACA-12RL-MS14F	3/4-20UNEF-2B	ø8.0 to ø12.0 (ø0.32 to 0.47)	7 (0.28)	13.8 (0.54)	24 (0.94)	26.4 (1.04)	6	23 (0.91)	25.3 (1.00)	6	41 (1.61)	43 (1.69)	38 (1.50)

# CHAPTER 11

## SELECTION

---

This chapter describes how to calculate the capacity of the servo motor needed for the machine used.

- 11-1 Specification symbol list
- 11-2 Position resolution and electronic gear setting
- 11-3 Speed and command pulse frequency
- 11-4 Stopping characteristics
- 11-5 Capacity selection
- 11-6 Load torque equations
- 11-7 Load inertia moment equations
- 11-8 Precautions for zeroing
- 11-9 Selection example

<b>INTRODUCTION</b>	<b>CHAPTER 1</b>
<b>OPERATION</b>	<b>CHAPTER 2</b>
<b>WIRING</b>	<b>CHAPTER 3</b>
<b>INSTALLATION</b>	<b>CHAPTER 4</b>
<b>ABSOLUTE POSITION DETECTION SYSTEM</b>	<b>CHAPTER 5</b>
<b>OPTIONS AND AUXILIARY EQUIPMENT</b>	<b>CHAPTER 6</b>
<b>INSPECTION</b>	<b>CHAPTER 7</b>
<b>TROUBLESHOOTING</b>	<b>CHAPTER 8</b>
<b>CHARACTERISTICS</b>	<b>CHAPTER 9</b>
<b>SPECIFICATIONS</b>	<b>CHAPTER 10</b>
<b>SELECTION</b>	<b>CHAPTER 11</b>

# 11. SELECTION

## 11-1 Specification symbol list

The following symbols are required for selecting the proper servo:

$T_a$ : Acceleration torque [N • m]	$\mu$ : Friction coefficient
$T_b$ : Deceleration torque [N • m]	$\pi$ : Circle ratio (3.14)
$T_{Ma}$ : Servo motor torque necessary for acceleration [N • m]	$P_t$ : Number of feedback pulses in position control mode [pulse/rev]
$T_{Mb}$ : Servo motor torque necessary for deceleration [N • m]	$f$ : Input pulse frequency in position control mode [pps]
$T_{LH}$ : Torque applied during servo motor stop [N • m]	$f_o$ : Input pulse frequency during fast feed in position control mode [pps]
$T_L$ : Load torque converted into equivalent value on servo motor shaft [N • m]	$T_{psa}$ : Acceleration time constant of frequency command in position control mode [s]
$T_{LM}$ : Load torque converted into equivalent value on servo motor shaft during stop [N • m]	$T_{psb}$ : Deceleration time constant of pulse frequency command in position control mode [s]
$T_U$ : Unbalance torque [N • m]	$K_p$ : Position control gain 1 [rad/s]
$T_F$ : Load friction torque [N • m]	$T_p$ : Position control time constant ( $T_p=1/K_p$ ) [s]
$T_{LO}$ : Load torque on load shaft [N • m]	$K_v$ : Speed control gain [rad/s]
$T_{rms}$ : Continuous effective load torque converted into equivalent value on servo motor shaft [N • m]	$T_v$ : Speed control time constant ( $T_v=1/K_v$ ) [s]
$J_L$ : Load inertia moment converted into equivalent value on servo motor shaft [kg • cm <sup>2</sup> ]	$\Delta \ell$ : Feed per feedback pulse in position control mode [mm/pulse]
$J_{LO}$ : Load inertia moment on load shaft [kg • cm <sup>2</sup> ]	$\Delta \ell_o$ : Feed per command pulse in position control mode [mm/pulse]
$J_M$ : Servo motor's rotor inertia moment [kg • cm <sup>2</sup> ]	$\ell$ : Feed [mm]
$N$ : Servo motor speed [r/min]	$P$ : Number of input command pulses in position control mode [pulse]
$N_o$ : Servo motor speed during fast feed [r/min]	$t_s$ : Settling time in position control mode [s]
$N_{LO}$ : Load shaft speed during fast feed [r/min]	$t_o$ : Positioning time [s]
$V$ : Moving part speed [mm/min]	$t_c$ : Time at constant speed of servo motor in 1 cycle [s]
$V_o$ : Moving part speed during fast feed [mm/min]	$t \ell$ : Stopping time in 1 cycle [s]
$P_B$ : Ball screw lead [mm]	$\Delta \epsilon$ : Positioning accuracy [mm]
$Z_1$ : Number of gear teeth on servo motor shaft	$\epsilon$ : Number of droop pulses [pulse]
$Z_2$ : Number of gear teeth on load gear	$\Delta \theta$ : Load shaft rotation angle per pulse in position control mode [degree/pulse]
$n$ : Gear ratio $n = \frac{Z_2}{Z_1}$ Speed reduced when $n > 1$ , Speed increased when $n < 1$	$e$ : Euler constant = 2.718278
$\eta$ : Drive system efficiency	$\Delta S$ : Feed per servo motor revolution [mm/rev]
$g$ : Gravitational acceleration (9.8[m/s <sup>2</sup> ])	



# 11. SELECTION

## 11-2 Position resolution and electronic gear setting

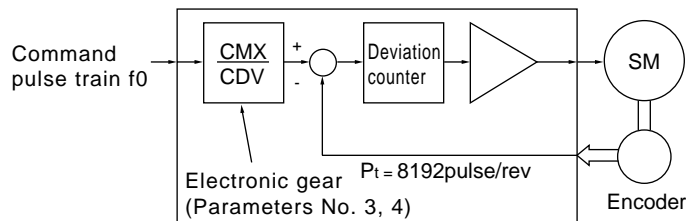
Position resolution (travel per pulse  $\Delta l$ ) is determined by travel per servo motor revolution  $\Delta S$  and the number of encoder feedback pulses  $P_t$ , and is represented by Equation 11-1:

$$\Delta l = \frac{\Delta S}{P_t} \dots\dots\dots (11-1)$$

- $\Delta l$  : Travel per pulse [mm]
- $\Delta S$  : Travel per servo motor revolution [mm/rev]
- $P_t$  : Number of feedback pulses [pulse/rev]

Note: As these values  $\Delta l$  depend on the servo motor series, confirm them in the specifications.

Since  $\Delta l$  has the relationship represented by Equation 11-1, its value is fixed in the control system after the drive system and encoder have been determined. However, travel per command pulse can be set as desired using the parameters.



As shown above, command pulses are multiplied by CMX/CDV set in the parameters to be position control pulses. Travel per command pulse  $\Delta l_o$  is expressed by Equation 11-2:

$$\Delta l_o = \frac{P_t}{\Delta S} \cdot \frac{CMX}{CDV} \Delta l \cdot \frac{CMX}{CDV} \dots\dots\dots (11-2)$$

- CMX: Electronic gear (Command pulse multiplication numerator)
- CDV: Electronic gear (Command pulse multiplication denominator)

Using the above relationship, travel per command pulse can be set to a value without fraction.

[Setting example]

Find a parameter value for  $\Delta l_o = 0.01$  [mm] in a drive system where ball screw lead  $PB = 10$  [mm] and reduction ratio  $1/n = 1$ .

The encoder feedback pulses  $P_t$  of the HC-MF = 8192 [pulses/rev].

Since  $\Delta s = 10$  [mm/rev], the following is obtained according to Equation 11-2:

$$\frac{CMX}{CDV} = \Delta l_o \cdot \frac{P_t}{\Delta S} = 0.01 \cdot \frac{8192}{10} = \frac{1024}{125}$$

<Relationship between position resolution  $\Delta l$  and overall accuracy>

Overall accuracy (positioning accuracy of machine) is the sum of electrical errors and mechanical errors. Normally, provisions should be made so that overall errors are not affected by electrical system errors. As a guideline, Equation 11-3 should be satisfied:

$$\Delta l < \left[ \frac{1}{5} \text{ to } \frac{1}{10} \right] \cdot \Delta \epsilon \dots\dots\dots (11-3)$$

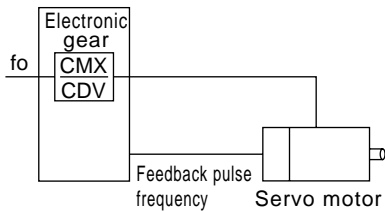
where,  $\Delta l$  : Travel per feedback pulse [mm/pulse]  
 $\Delta \epsilon$ : Positioning accuracy [mm]

# 11. SELECTION

## 11-3 Speed and command pulse frequency

The servo motor is run at a speed where the command pulses and feedback pulses are equivalent. Therefore, the command pulse frequency and feedback pulse frequency are equivalent. The relation including the parameter settings (CMX, CDV) is as indicated below (refer to the following diagram):

$$f_o \cdot \frac{CMX}{CDV} = P_t \cdot \frac{N_o}{60} \dots\dots\dots (11-4)$$



- $f_o$  : Command pulse frequency [pps] (Open collector system)
- CMX : Electronic gear (Command pulse multiplication numerator)
- CDV : Electronic gear (Command pulse multiplication denominator)
- $N_o$  : Servo motor speed [r/min]
- $P_t$  : Number of feedback pulses [pulses/rev] ( $P_t = 8192$  for HC-MF)

According to Equation 11-4, the following equations may be used to obtain the electronic gear and command pulse frequency to rotate the servo motor at  $N_o$ .

- Electronic gear

$$\frac{CMX}{CDV} = P \cdot \frac{N_o}{60} \cdot \frac{1}{f_o} \dots\dots\dots (11-5)$$

- Command pulse frequency

$$f_o = P_t \cdot \frac{N_o}{60} \cdot \frac{CDV}{CMX} \dots\dots\dots (11-6)$$

[Setting example]

Obtain the command pulse frequency required to run the HC-MF at 3000r/min.

When the electronic gear ratio 1 (initial parameter value) is used, the following result is found according to Equation 11-6:

$$f_o = 8192_t \cdot \frac{N_o}{60} \cdot \frac{CDV}{CMX}$$

(Command pulse frequency)

$$= 8192_t \cdot \frac{3000}{60} \cdot 1$$

$$= 409600[\text{pps}]$$

However, as the maximum input command pulse frequency in the open collector system is 200kpps, 409600pps cannot be entered.

To run the servo motor at the speed of 3000r/min at not more than 200kpps, the electronic gear setting must be changed. This electronic gear is found by Equation 11-5:

$$\frac{CMX}{CDV} = 8192 \cdot \frac{3000}{60} \cdot \frac{1}{200 \times 10^3}$$

(Electronic gear)

$$= \frac{256}{125}$$

Therefore, the parameters are set to CMX=256 and CDV=125.

# 11. SELECTION

## 11-4 Stopping characteristics

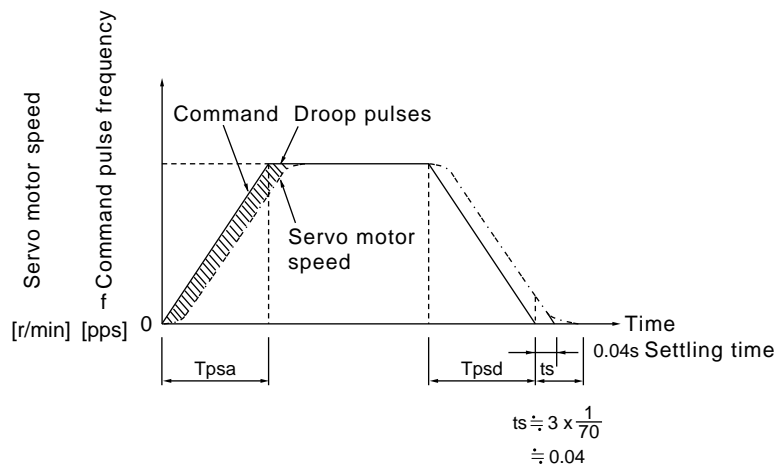
### (1) Droop pulses ( $\epsilon$ )

When a pulse train command is used to run the servo motor, there is a relationship between the command pulse frequency and servo motor speed as shown in the figure. The difference between the command pulses and feedback pulses during acceleration are called droop pulses, which are accumulated in the servo amplifier's deviation counter. Equation 11-7 defines a relationship between the command pulse frequency ( $f$ ) and position control gain 1 ( $K_p$ ).

$$\epsilon \doteq \frac{f_0}{K_p} \text{ [pulse]} \dots\dots\dots (11-7)$$

Supposing that the value of position control gain 1 is 70 [rad/s], the droop pulses during operation will be as follows at the command pulse frequency of 200 [kpps] according to Equation 11-7:

$$\epsilon \doteq \frac{200 \times 10^3}{70} \doteq 2858 \text{ [pulse]}$$



### (2) Settling time ( $t_s$ ) during linear acceleration/deceleration

Since droop pulses still exist when there are no command pulses, settling time ( $t_s$ ) is required until the servo motor stops. Set the operation pattern in consideration for the settling time.

The  $t_s$  value is obtained according to Equation 11-8:

$$t_s \doteq 3 \cdot T_p$$

$$= 3 \cdot \frac{1}{K_p} \text{ [s]} \dots\dots\dots (11-8)$$

\*When  $K_p=70$  [rad/s],  $t_s \doteq 0.04$  [s]. (Refer to the above diagram.)

Note: The settling time ( $t_s$ ) indicates the time required for the servo motor to stop in the necessary positioning accuracy range. This does not always mean that the servo motor has stopped completely. Thus, especially when the servo motor is used in high-duty operation and positioning accuracy has no margin for travel per pulse ( $\Delta \ell$ ), the value obtained by Equation 11-8 must be increased.

$t_s$  will vary with the moving part conditions. Especially when the load friction torque is large, movement may be unstable near the stopping position.

# 11. SELECTION

## 11-5 Capacity selection

As a first step, temporarily select the servo motor capacity by calculating the load conditions. Next, determine the command pattern, calculate required torques according to the following equations, and confirm that the servo motor of the initially selected capacity may be used for operation.

### (1) Initial selection of servo motor capacity

After calculating the load torque ( $T_L$ ) and load inertia moment ( $J_L$ ), select a servo motor which will satisfy the following two relationships:

Servo motor's rated torque  $> T_L$

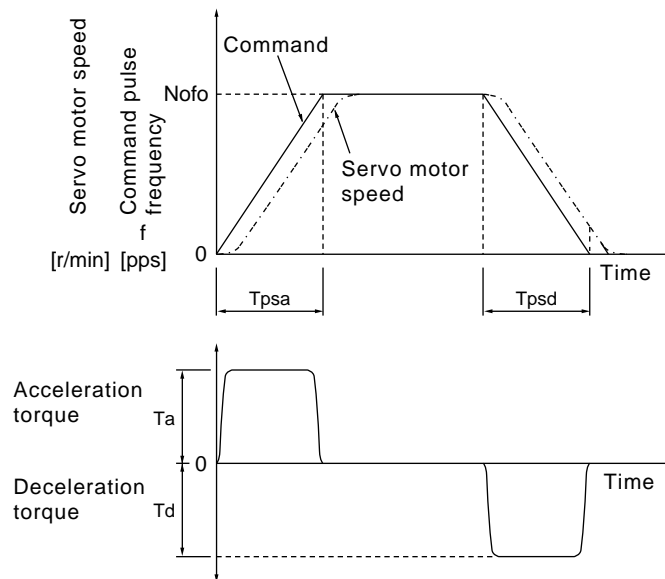
Servo motor  $J_M > J_L/m$

- $m=3$  : High duty (more than 100 times/min.)  
Settling time 40ms or less
- $m=5$  : Middle duty (60 to 100 times/min.)  
Settling time 100ms or less
- $m = \text{permissible load inertia moment}$  : Low duty (less than 60 times/min.)  
Settling time more than 100ms

Find the acceleration and deceleration torques and continuous effective load torque as described in (2) to make a final selection. For high-duty positioning, the  $J_L$  value should be as small as possible. If positioning is infrequent as in line control, the  $J_L$  value may be slightly larger than in the above conditions.

### (2) Acceleration and deceleration torques

The following equations are used to calculate the acceleration and deceleration torques in the following operation pattern:



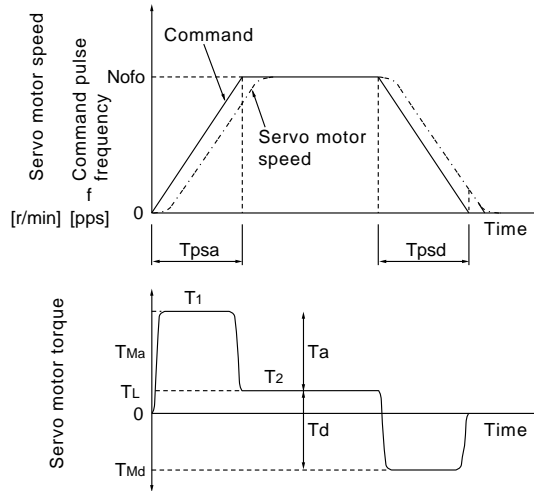
• Acceleration torque  $T_a = \frac{(J_L + J_M) \cdot N_o}{9.55 \times 10^4} \cdot \frac{1}{T_{psa}} \dots\dots\dots (11-9)$

• Deceleration torque  $T_b = \frac{(J_L + J_M) \cdot N_o}{9.55 \times 10^4} \cdot \frac{1}{T_{psd}} \dots\dots\dots (11-10)$

### (3) Torques required for operation

Torques required for the servo motor are the highest during acceleration. If any of the torques obtained with Equations 11-9 to 11-13 exceeds the maximum servo motor torque, the servo motor speed cannot be increased as commanded. Confirm that the calculated value is lower than the servo motor's maximum torque. Since a friction load is normally applied during deceleration, only the acceleration torque needs to be considered.

# 11. SELECTION



$$T_1 = T_{Ma} + T_a + T_L \dots\dots\dots (11-11)$$

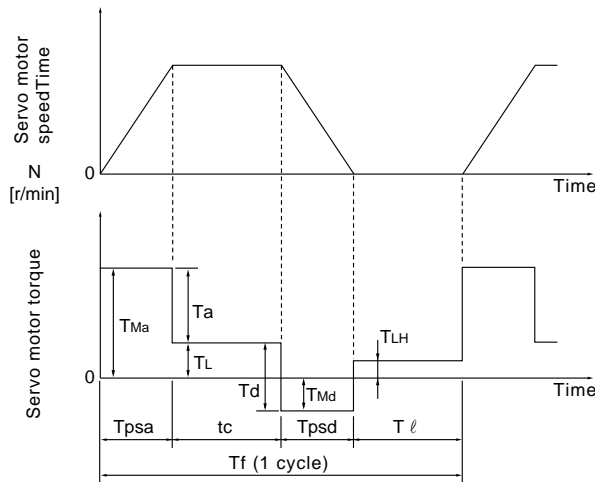
$$T_2 = T_L \dots\dots\dots (11-12)$$

$$T_3 = T_{Md} = -T_d + T_L \dots\dots\dots (11-13)$$

Note: In the regenerative mode, the value found by Equation 11-13 is negative.

## (4) Continuous effective load torque

If the torque required for the servo motor changes with time, the continuous effective load torque should be lower than the rated torque of the servo motor. There may be a servo motor torque delay at the start of acceleration or deceleration due to a delay in the control system. To simplify the calculation, however, it is assumed that constant acceleration and deceleration torques are applied during  $T_{psa}$  and  $T_{psd}$ . The following equation is used to calculate the continuous effective load torque in the following operation pattern:



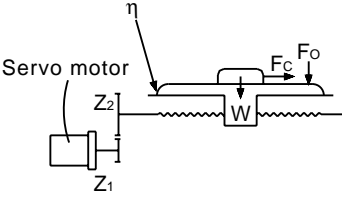
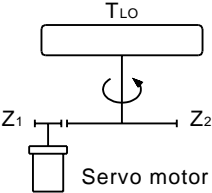
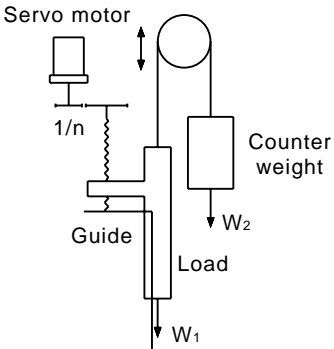
$$T_{rms} = \sqrt{\frac{T_{Ma}^2 \cdot T_{psa} + T_L^2 \cdot t_c + T_{Md}^2 \cdot T_{psd} + T_{LH} \cdot t_l}{t_f}} \dots\dots\dots (11-14)$$

Note:  $T_{LH}$  indicates the torque applied during a servo motor stop. A large torque may be applied especially during a stop in vertical motion applications, and this must be fully taken into consideration. During vertical drive, the unbalanced torque  $T_U$  will become  $T_{LH}$ .

# 11. SELECTION

## 11-6 Load torque equations

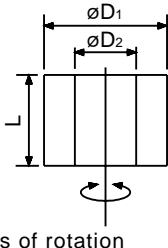
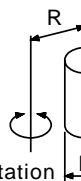
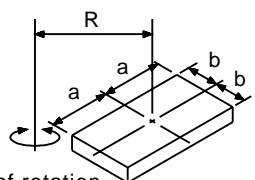
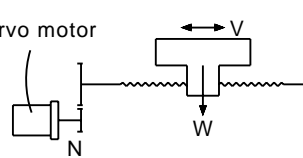
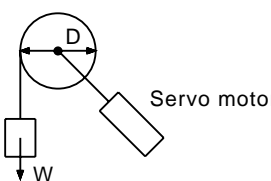
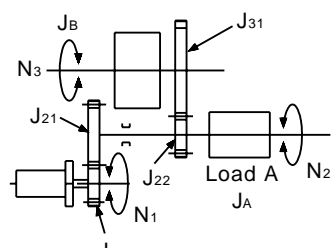
Typical load torque equations are indicated below:  
Load Torque Equations

Type	Mechanism	Equation
Linear movement		$T_L = \frac{F}{2 \times 10^3 \cdot \pi \cdot \eta} \cdot \frac{V}{N} = \frac{F \cdot \Delta S}{2 \times 10^3 \cdot \pi \cdot \eta} \dots\dots\dots (11-15)$ <p>F : Force in the axial direction of the machine in linear motion [N] F in Equation 11-15 is obtained with Equation 11-16 when the table is moved, for example, as shown in the left diagram.</p> $F = F_c + \mu \cdot (W \cdot g + F_0) \dots\dots\dots (11-16)$ <p>F<sub>c</sub> : Force applied in the axial direction of the moving part [N] F<sub>0</sub> : Tightening force of the table guide surface [N] W : Full weight of the moving part [kg]</p>
Rotary movement		$T_L = \frac{1}{n} \cdot \frac{1}{\eta} \cdot T_{LO} + T_F \dots\dots\dots (11-17)$ <p>T<sub>F</sub>: Load friction torque converted into equivalent value on servo motor shaft [N • m]</p>
Vertical movement		<p>During rise</p> $T_L = T_U + T_F \dots\dots\dots (11-18)$ <p>During fall</p> $T_L = - T_U \cdot \eta^2 + T_F \dots\dots\dots (11-19)$ <p>T<sub>F</sub>: Friction torque of the moving part [N • m]</p> $T_U = \frac{(W_1 - W_2) \cdot g}{2 \times 10^3 \cdot \pi \cdot \eta} \cdot \frac{V}{N} = \frac{(W_1 - W_2) \cdot g \cdot \Delta S}{2 \cdot 10^3 \cdot \pi \cdot \eta} \dots\dots\dots (11-20)$ $T_F = \frac{\mu(W_1 + W_2) \cdot g \cdot \Delta S}{2 \times 10^3 \cdot \pi \cdot \eta} \dots\dots\dots (11-21)$ <p>W<sub>1</sub> : Weight of load [kg] W<sub>2</sub> : Weight of counterweight [kg]</p>

# 11. SELECTION

## 11-7 Load inertia moment equations

Typical load inertia moment equations are indicated below:  
Load Inertia Moment Equations

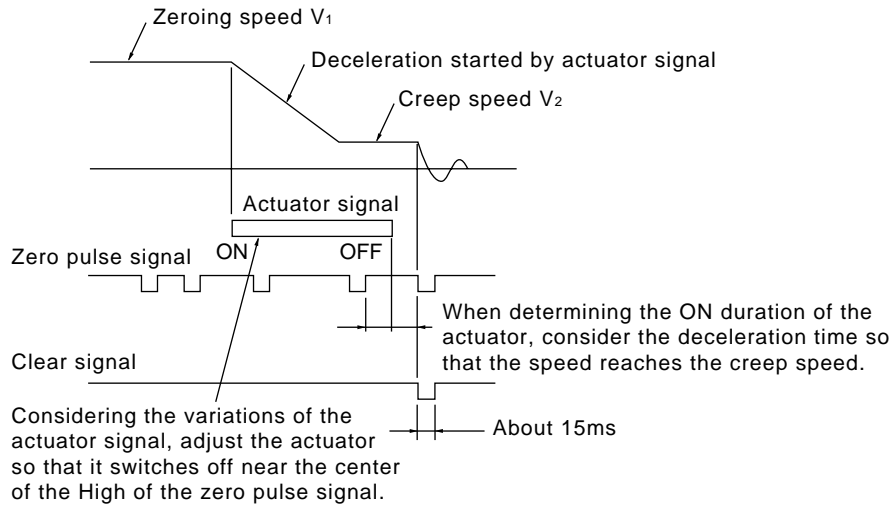
Type	Mechanism	Equation
Cylinder	Axis of rotation is on the cylinder center 	$J_{LO} = \frac{\pi \cdot \rho \cdot L}{32} \cdot (D_1^4 - D_2^4) = \frac{W}{8} \cdot (D_1^2 + D_2^2) \dots\dots (11-22)$ <p> <math>\rho</math> : Cylinder material density [kg/cm<sup>3</sup>]  <math>L</math> : Cylinder length [cm]  <math>D_1</math> : Cylinder outside diameter [cm]  <math>D_2</math> : Cylinder inside diameter [cm]  <math>W</math> : Cylinder weight [kg]           </p> <p>Reference data: material density            Iron : 7.8 x 10<sup>-3</sup> [kg/cm<sup>3</sup>]            Aluminum : 2.7 x 10<sup>-3</sup> [kg/cm<sup>3</sup>]            Copper : 8.96 x 10<sup>-3</sup> [kg/cm<sup>3</sup>]</p>
	Axis of rotation is off the cylinder center 	$J_{LO} = \frac{W}{8} \cdot (D^2 + 8R^2) \dots\dots\dots (11-23)$
Square block		$J_{LO} = W \cdot \left( \frac{a^2 + b^2}{3} + R^2 \right) \dots\dots\dots (11-24)$ <p> <math>W</math> : Square block weight [kg]  <math>a, b, R</math> : Left diagram [cm]           </p>
Object which moves linearly		$J_L = W \cdot \frac{V}{600 \cdot \omega} = W \cdot \left( \frac{1}{2 \cdot \pi \cdot N} \cdot \frac{V}{10} \right)^2 = W \cdot \left( \frac{\Delta S}{20 \cdot \pi} \right)^2 \dots\dots\dots (11-25)$ <p> <math>V</math> : Speed of object moving linearly [mm/min]  <math>\Delta S</math> : Moving distance of object moving linearly per servo motor revolution [mm/rev]  <math>W</math> : Object weight [kg]           </p>
Object that is hung with pulley		$J_L = W \cdot \left( \frac{D}{2} \right)^2 + J_P \dots\dots\dots (11-26)$ <p> <math>J_P</math> : Pulley inertia moment [kg • cm<sup>2</sup>]  <math>D</math> : Pulley diameter [cm]  <math>W</math> : Object weight [kg]           </p>
Converted load		$J_L = J_{11} = (J_{21} + J_{22} + J_A) \cdot \left( \frac{N_2}{N_1} \right)^2 + (J_{31} + J_B) \cdot \left( \frac{N_3}{N_1} \right)^2 \dots\dots\dots (11-27)$ <p> <math>J_A, J_B</math> : Inertia moments of loads A, B [kg • cm<sup>2</sup>]  <math>J_{11}</math> to <math>J_{31}</math> : Inertia moments [kg • cm<sup>2</sup>]  <math>N_1</math> to <math>N_3</math> : Speed of each shaft [r/min]           </p>

# 11. SELECTION

## 11-8 Precautions for zeroing

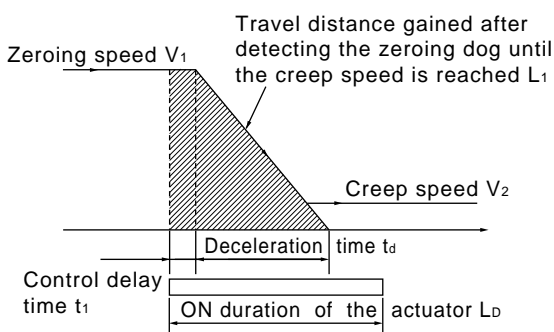
To return the system to the home position, use a zeroing dog or actuator. The method and precautions for setting the mechanical origin are given below.

In the following zeroing, an actuator and the zero pulse signal (encoder Z-phase pulse OP) of a servo motor encoder are used to set the mechanical origin. The state of ON/OFF of encoder Z-phase pulse signal (OP) can be confirmed by using external I/Q signal display function. When a general positioning unit is used, the sequence of events is as shown in Fig. 11-1.



**Fig. 11-1 Zeroing Using the Actuator**

- (1) When determining the ON duration of the actuator, consider the delay time of the control section and the deceleration time so that the creep speed is attained. If the actuator signal switches off during deceleration, precise home position return cannot be performed.



- Travel distance  $L_1$  in the chart can be obtained by Equation 11-28
- ON duration of the actuator  $L_D$  [mm] must be longer than  $L_1$  obtained by Equation 11-28, as indicated in Equation 11-29.

$$L_1 = \frac{1}{60} \cdot V_1 \cdot t_1 + \frac{1}{120} \cdot V_1 \cdot t_d \cdot \left\{ 1 - \left( \frac{V_2}{V_1} \right)^2 \right\} + \frac{1}{60} \cdot V_1 \cdot T_p \quad \dots\dots (11-28)$$

$$L_D > L_1 \quad \dots\dots (11-29)$$

where,

$V_1, V_2$  : As shown in the chart [mm/min]

$t_1, t_d$  : As shown in the chart [s]

$L_1$  : As shown in the chart [mm]

$L_D$  : As shown in the chart [mm]

- (2) Set the end (OFF position) of the actuator signal at the middle of two ON positions (Lows) of the zero pulse signal. If it is set near either ON position of the zero pulse signal, the positioning unit is liable to misdetect the zero pulse signal. In this case, a fault will occur, e.g. the home position will shift by one revolution of the servo motor.

The zero pulse output position can be confirmed by OP (encoder Z-phase pulse) on the external I/O signal display.

- (3) Set the creep speed at which the machine is not shocked at a stop.

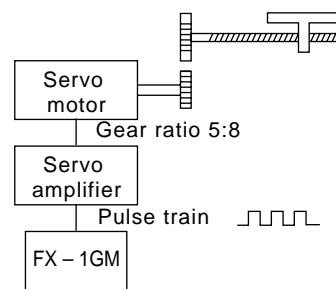
The machine will stop suddenly as the clear (CR) signal is given to the servo amplifier on detection of the zero pulse signal.



# 11. SELECTION

## 11-9 Selection example

Machine specifications



Speed of moving part during fast feed	$V_o = 30000 \text{ mm/min}$
Travel per pulse	$\Delta l = 0.005 \text{ mm}$
Travel	$l = 400 \text{ mm}$
Positioning time	$t_o = \text{within } 1 \text{ s}$
Number of feeds	40 times/min.
Operation cycle	$t_f = 1.5 \text{ s}$
Gear ratio	$n = 8/5$
Moving part weight	$W = 60 \text{ kg}$
Drive system efficiency	$\eta = 0.8$
Friction coefficient	$\mu = 0.2$
Ball screw lead	$P_b = 16 \text{ mm}$
Ball screw diameter	20mm
Ball screw length	500mm
Gear diameter (servo motor)	25mm
Gear diameter (load shaft)	40mm
Gear face width	10mm

### (1) Selection of control parameters

#### 1) Setting of electronic gear (command pulse multiplication numerator, denominator)

There is the following relationship between the multiplication setting and travel per pulse  $\Delta l$ .

$$\Delta l = \frac{(\text{ball screw lead})}{8192 \times (\text{gear ratio})} \times \left( \frac{\text{CMX}}{\text{CDV}} \right)$$

When the above machining specifications are substituted in the above equation:

$$\frac{\text{CMX}}{\text{CDV}} = 0.005 \cdot \frac{8192 \cdot 8/5}{16} = \frac{512}{125}$$

Acceptable as CMX/CDV is within 1/50 to 20.

#### 2) Input pulse train frequency for rapid feed $f_o$

$$f_o = \frac{V_o}{60 \cdot \Delta R} = \frac{30000}{60 \cdot 0.005} = 100000 \text{ [pps]}$$

Acceptable as  $f_o$  is not more than 200kpps.

### (2) Servo motor speed

$$N_o = \frac{V_o}{P_b} \cdot n = 3000 \text{ [r/min]}$$

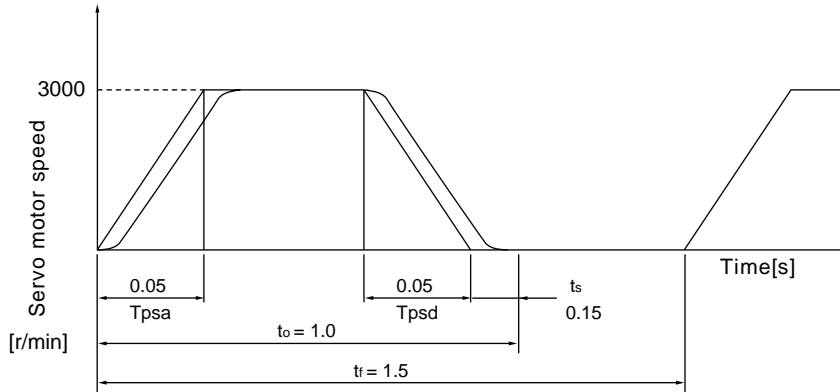
### (3) Acceleration/deceleration time constant

$$T_{psa} = T_{psd} = t_o - \frac{l}{V_o/60} - t_s = 0.05 \text{ [s]}$$

\* $t_s$ : settling time. (Here, this is assumed to be 0.15s.)

# 11. SELECTION

## (4) Operation pattern



## (5) Load torque (converted into equivalent value on servo motor shaft)

Travel per servo motor revolution

$$\Delta S = P_B \cdot \frac{1}{n} = 10[\text{mm}]$$

$$T_L = \frac{\mu \cdot W \cdot g \cdot \Delta S}{2 \times 10^3 \cdot \pi \cdot \eta} = 0.23[\text{N} \cdot \text{m}]$$

## (6) Load inertia moment (converted into equivalent value on servo motor shaft)

Moving part

$$J_{L1} = W \cdot \left( \frac{\Delta S}{20\pi} \right)^2 = 1.52[\text{kg} \cdot \text{cm}^2]$$

Ball screw

$$J_{L2} = \frac{\pi \cdot \rho \cdot L}{32} \cdot D^4 \cdot \left( \frac{1}{n} \right)^2 = 0.24[\text{kg} \cdot \text{cm}^2]$$

$$*\rho = 7.8 \times 10^{-3}[\text{kg}/\text{cm}^3]$$

Gear (servo motor shaft)

$$J_{L3} = \frac{\pi \cdot \rho \cdot L}{32} \cdot D^4 = 0.03[\text{kg} \cdot \text{cm}^2]$$

Gear (load shaft)

$$J_{L4} = \frac{\pi \cdot \rho \cdot L}{32} \cdot D^4 \cdot \left( \frac{1}{n} \right)^2 = 0.8[\text{kg} \cdot \text{cm}^2]$$

Full load inertia moment (converted into equivalent value on servo motor shaft)

$$J_L = J_{L1} + J_{L2} + J_{L3} + J_{L4} = 1.9[\text{kg} \cdot \text{cm}^2]$$

## (7) Temporary selection of servo motor

Selection conditions

- 1) Load torque < servo motor's rated torque
  - 2) Full load inertia moment < 30 x servo motor inertia moment
- From the above, the HC-MF23 (200W) is temporarily selected.

# 11. SELECTION

## (8) Acceleration and deceleration torques

Torque required for servo motor during acceleration

$$T_{Ma} = \frac{(J_L + J_M) \cdot N_o}{9.55 \times 10^4 \cdot T_{psa}} + T_L = 1.7[\text{N} \cdot \text{m}]$$

Torque required for servo motor during deceleration

$$T_{Md} = \frac{(J_L + J_M) \cdot N_o}{9.55 \times 10^4 \cdot T_{psd}} + T_L = -1.2[\text{N} \cdot \text{m}]$$

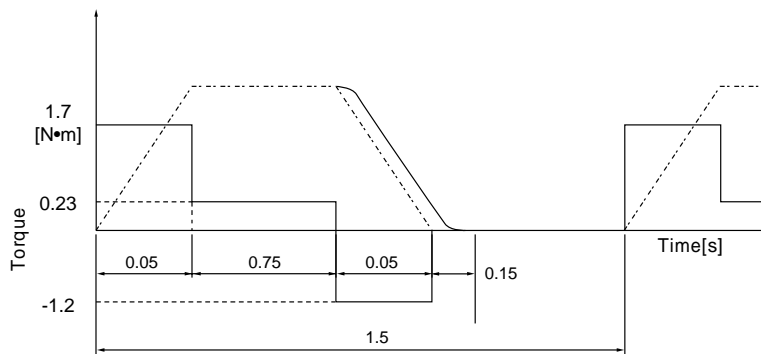
The torque required for the servo motor during deceleration must be lower than the servo motor's maximum torque.

## (9) Continuous effective load torque

$$T_{rms} = \sqrt{\frac{T_{Ma}^2 \cdot T_{psa} + T_L^2 \cdot t_c + T_{Md}^2 \cdot T_{psd}}{t_f}} = 0.41[\text{N} \cdot \text{m}]$$

The continuous effective load torque must be lower than the servo motor's rated torque.

## (10) Torque pattern



## (11) Selection results

The HC-MF23 servo motor and MR-J2-20A servo amplifier are selected.

### 1) Electronic gear setting

Parameter No. 3	Command pulse multiplication numerator (CMX)	512
Parameter No. 4	Command pulse multiplication denominator (CDV)	125

### 2) During rapid feed

- Servo motor speed .....  $N_o = 3000$  [r/min]
- Input pulse train frequency .....  $f_o = 100$  [kpps]

### 3) Acceleration/deceleration time constant

$$T_{psa} = T_{psd} = 0.05[\text{s}]$$

## REVISIONS

\*The manual number is given on the bottom left of the back cover.

Print Data	*Manual Number	Revision
Nov., 1996	IB(NA)67286-A	First edition
Mar., 1997	IB(NA)67286-B	<p>Addition of servo amplifiers MR-J2-70 to 350A and single-phase 100V power supply models</p> <p>Addition of servo motors HC-MF73, HC-SF series and HC-RF series</p> <p>Section 2-1                      Addition of notes on servo motor connection</p> <p>Section 2-2-2                  Addition of stop by reset signal</p> <p>Section 2-3-2                  Correction to display range for position within one revolution</p> <p>3), (1), Section 2-3-3        Addition of default indications</p> <p>(4), Section 2-3-5              Parameter No. 0: Addition of MR-RB30, MR-RB50</p> <p>   Parameter No. 11, 13: Changes to diagrams</p> <p>Section 2-4-2                  Changes to Step 2 in Adjustment 5</p> <p>(2), Section 3-1-2              Corrections to errors in writing of signals in table</p> <p>(4), Section 3-1-2              Signals which can be used by parameter setting are indicated by Δ.</p> <p>1), (4), section 3-1-2        Addition of sentence to Reset</p> <p>2), (4), section 3-1-2        Changes to sentences on encoder A-, B- and Z-phase pulses</p> <p>1), (3), Section 3-1-4        Addition of note</p> <p>Section 3-2-2                  Overall change</p> <p>Section 3-2-3                  Overall change</p> <p>Section 3-2-4                  Additions</p> <p>Section 3-3                      Corrections to errors in diagram</p> <p>(2), Section 3-5                Addition of sentence</p> <p>(2), Section 4-1                Changes to installation clearances</p> <p>(7), Section 4-2                Changes to graph</p> <p>(7) Chapter 5                  Changes to sentence in Note 5</p> <p>(1), Section 6-1-1              Changes to table</p> <p>(5), Section 6-1-1              Addition of MR-RB30 and 50 diagrams</p> <p>(1), Section 6-1-2              Connector outline drawings are moved to Section 10-5-3.</p> <p>(2), Section 6-1-2              Addition of UL20276AWG227 pair (BLACK)</p> <p>b, 1), (2), Section 6-1-2      Addition of connection diagram for use of AWG28</p> <p>3), (2), Section 6-1-2        Addition of bus cable</p> <p>Section 6-1-4                  Addition of maintenance junction card</p> <p>Section 6-2-5                  Change to Matsushita Electric's varistor model number</p> <p>Section 10-5-1                Entry of terminal signal arrangement</p> <p>Section 10-5-4                Entry of cable side plug outline drawings</p>

## REVISIONS

\*The manual number is given on the bottom left of the back cover.

Print Data	*Manual Number	Revision
Oct., 1997	IB(NA)67286-C	<p>Instructions added for compliance with the UL/C-UL Standard</p> <p>Addition of single-phase 230VAC input power supply</p> <p>Section 2-2-2, (2) to (4) Deletion of reset-on stop operation</p> <p>Section 2-3-5, (4) Correction made to LSP/LSN signal stop pattern selection in parameter No. 22</p> <p>Section 3-1-2, (4), (2) Correction made to description of encoder Z-phase pulse functions and applications</p> <p>Section 3-1-4, (7) Addition of source input interface</p> <p>Section 3-2-3, (4) Addition of electromagnetic brake connector</p> <p>Section 3-3 Change in P15R connection</p> <p>Section 3-5, (2), (4) Addition of VDD-COM connection</p> <p>Section 3-7, (3), (2) Deletion of reset signal ON/OFF</p> <p>Section 6-1-2, (2), (1) Change in connection diagram</p> <p>Section 6-1-2, (2), (3) Change in connector type</p> <p>Section 6-2-1 Change in UVW cable size</p> <p>Section 6-2-2 Deletion of text</p> <p>Section 9-2 Change in Note 1</p> <p>Section 9-3 Addition of electromagnetic brake characteristics of HC-SF/HC-RF</p> <p>Section 9-4 Change in dynamic brake's brakable load inertia moment ratio</p> <p>Section 10-2, (3) Correction made to HC-SF graph</p> <p>Section 10-3 Addition of reduction gears for use with HC-SF/HC-RF</p> <p>Section 10-4 Change in shaft end machining diagram for HC-SF/HC-RF</p> <p>Section 10-5-2 Addition of HC-SF/HC-RF servo motors with electromagnetic brakes</p>
Nov., 1998	IB(NA)67286-D	<p>Changes made to the instructions for compliance with the UL/C-UL Standard</p> <p>Section 1-1, (2) Deletion of model explanation</p> <p>Section 1-1-2 Addition of model makeup</p> <p>Section 1-1-3 Addition of combinations with servo motors</p> <p>Section 3-1-3, (1), (4) Addition of pulse train input</p> <p>Section 3-1-3, (3), (1), a Reconsideration of rotation direction for negative polarity in Table 3-4</p> <p>Section 3-2-2 Deletion of servo motor shape</p> <p>Section 3-2-3, (3) Addition of HC-UF3000r/min series</p> <p>Section 3-2-3, (5) Addition of HC-UF2000r/min series</p> <p>Ex-Section 3-2-4 Deletion of selection of the cable plug</p> <p>Section 3-2-4 Addition of connectors used for servo motor wiring</p> <p>Section 6-2-2 Deletion of fuse models</p> <p>Section 9-1, (2) Addition of data for MR-J2-200C/350C</p> <p>Section 9-2 Addition of HC-SF81 to 301/HC-SF103 to 353/HC-UF72 to 202/HC-UF13 to 73</p> <p>Section 9-3 Addition of HC-SF81 to 301/HC-SF103 to 353/HC-UF72 to 202/HC-UF13 to 73</p> <p>Section 10-5-2, (5) Addition of HC-SF81 to 301/HC-SF103 to 353</p> <p>Section 10-5-2, (7) Addition of HC-UF series</p>

## REVISIONS

\*The manual number is given on the bottom left of the back cover.

Print Data	*Manual Number	Revision
May,2000	IB(NA)67286-E	<p>Addition of compliance to EC directive 1 (1), (2), (3)</p> <p>Addition of 2. Cautions for appliance (1) Servo amplifier and servo motor to be used to EC directive Addition of (6) ③.</p> <p>UL/C-UL Standard (1) Addition of servo amplifier and servo motor to be used</p> <p>UL/C-UL Standard (4) Change in flange table</p> <p>UL/C-UL Standard (2) Addition of optional parts and peripheral devices</p> <p>Section 1-1-2 (1) Change in rating name plate</p> <p>Section 2-3-5 (4) Change of parameter detail description No. 2 initial value to 0002 Addition of some text to parameter No. 47 Addition of some text to parameter No. 48</p> <p>Chapter 3 Addition of caution drawing</p> <p>Section 3-1-2 (4)① Change to emergency stop</p> <p>Section 3-1-2 (4)② Change in max. pulse width of detector Z-phase pulse to 400</p> <p>Section 3-1-3 (6) Addition to figure of timing chart for switching</p> <p>Section 3-1-4 (1) Partial change in drawing of digital interface D1-1</p> <p>Section 3-1-4 (2) Partial change in figure</p> <p>Section 3-1-4 (3) Partial change in figure</p> <p>Section 3-2-4 (1) Change of servo motor side connector to 1-172169-9</p> <p>Section 3-3 Partial deletion of figure</p> <p>Section 3-6 Partial change in figure of timing chart at the time of occurrence of alarm</p> <p>Section 3-7 Addition of point</p> <p>Section 3-7 (1) Partial change in connection diagram</p> <p>Section 3-7 (3) (a) Change in text</p> <p>Section 3-7 (3) (b) Partial change in figure</p> <p>Section 3-7 (3) (c) Partial change in figure</p> <p>Section 3-7 (3) (d) Partial change in figure</p> <p>Section 4-2 (4) Deletion of shaft allowable load table (kgf)</p> <p>Section 6-1-2 (2)② Change of signals listed in relay terminal block side table of detector cable connection diagram to those abbreviated</p> <p>Section 6-1-3 Addition of point</p> <p>Section 6-2-6 (2) Change in diode mounting drawing</p> <p>Section 8-1-1 (2) Partial change in figure Addition of some text</p> <p>Section 8-2-2 Addition of A. 25 Trouble, Cause Remedy</p> <p>Section 9-3 (1) Deletion of Table 9-2 (kgf.cm)</p> <p>Section 10-1 (2) Deletion of Table (kgf.cm)</p> <p>Section 10-5-2 (1) Change in all HC-MF series</p> <p>Section 10-5-2 (2) Change in HC-MF-UE series</p> <p>Section 10-5-2 (5) Change in HC-UF3000 rpm series</p> <p>Section 10-5-3 (3) Change of servo motor detector plug</p>

Headquarters		European Representatives	
<b>Headquarters</b> MITSUBISHI ELECTRIC EUROPE B.V. Gothaer Str. 8 <b>D-40880 Ratingen</b> <b>GERMANY</b> Phone: +49 (0) 2102/486-0 Fax: +49 (0) 2102/486-112		<b>European Representatives</b>	
<b>EUROPE</b>	N.V. GETRONICS Belgium S.A. Pontbeeklaan 43 <b>B-1731 Asse-Zellik</b> Telefon +32 (0) 2 / 467 17 51 Fax: +32 (0) 2 / 467 17 45	<b>BELGIUM</b>	STC Drive Technique Poslannikov per., 9, str.1 <b>RUS-107005 Moskow</b> Telefon +7 (0) 95 / 786 21 00 Fax: +7 (0) 95 / 786 21 01
	TELECON CO. 4, A. Ljapchev Blvd. <b>BG-1756 Sofia</b> Telefon +359 2 97 44 05 8 Fax: +359 2 97 44 06 1	<b>BULGARIA</b>	ECONOTEC AG Postfach 282 <b>CH-8309 Nürens Dorf</b> Telefon +41 (0) 1 / 838 48 11 Fax: +41 (0) 1 / 838 48 12
<b>ITALY</b>	Iouis poulsen Geminivej 32 <b>DK-2670 Greve</b> Telefon +45 (0) 43 / 95 95 95 Fax: +45 (0) 43 / 95 95 91	<b>DENMARK</b>	INEA d.o.o. Ljubljanska 80 <b>SI-61230 Domzale</b> Telefon +386 (0) 17 21 80 00 Fax: +386 (0) 17 24 16 72
	URHO TUOMINEN OY Hevoshaankatu 3 <b>FIN-28600 Pori</b> Telefon +358 (0) 2 / 550 800 Fax: +358 (0) 2 / 550 8841	<b>FINLAND</b>	AutoCont Control Systems s.r.o. Nemocnicni 12 <b>CZ-702 00 Ostrava 2</b> Telefon +420 (0) 69 / 615 21 11 Fax: +420 (0) 69 / 615 21 12
<b>JAPAN</b>	Etudes Ingénierie Automation S.A. 208, Avenue du 8 Mai 1945 <b>F-69165 Rillieux La Pape Cédex</b> Telefon +33 (0) 4 / 72 01 44 88 Fax: +33 (0) 4 / 78 88 14 02	<b>FRANCE</b>	GTS Darülaceze Cad. No. 43A KAT: 2 <b>TR-80270 Okmeydani-Istanbul</b> Telefon +90 (0) 212 / 320 1640 Fax: +90 (0) 212 / 320 1649
	IP Systèmes 8, Rue du Colonel Chambonnet <b>F-69672 Lyon Bron Cedex</b> Telefon +33 (0) 4 / 72 14 18 00 Fax: +33 (0) 4 / 72 14 18 01	<b>FRANCE</b>	
<b>SPAIN</b>	MITSUBISHI ELECTRIC EUROPE B.V. Pol. Ind. Can Magi-C. Joan Buscallá, 2-4 AC 420 <b>E-08190 Sant Cugat del Vallés (Barcelona)</b> <b>SPAIN</b> Phone: +34 9 3/565 31 60 Fax: +34 9 3/589 15 79		<b>TURKEY</b>
	MITSUBISHI ELECTRIC EUROPE B.V. Travellers Lane <b>GB-Hatfield Herts. AL10 8 XB</b> <b>UK</b> Phone: +44 (0) 1707/27 61 00 Fax: +44 (0) 1707/27 86 95		
<b>UK</b>	UTECO A.B.E.E. 5, Mavrogenous Str. <b>GR-18542 Piraeus</b> Telefon +30 (0) 1 / 42 10 050 Fax: +30 (0) 1 / 42 12 033	<b>GREECE</b>	
	MITSUBISHI ELECTRIC EUROPE B.V. Westgate Business Park, Ballymount <b>IRL-Dublin 24</b> Telefon +353 (0) 1 / 419 88 00 Fax: +353 (0) 1 / 419 88 90	<b>IRELAND</b>	
<b>USA</b>	SHERF Motion Techn. LTD Rehov Hamerkava 19 <b>IL-58851 Holon</b> Telefon +972 (0) 3 / 559 54 62 Fax: +972 (0) 3 / 556 01 82	<b>ISRAEL</b>	
	Getronics Industrial Automation bv Donauweg 10 <b>NL-1043 AJ Amsterdam</b> Telefon +31 (0) 20 / 586 15 92 Fax: +31 (0) 20 / 586 19 27	<b>NETHERLANDS</b>	
	GEVA Wiener Straße 89 <b>A-2500 Baden</b> Telefon +43 (0) 2252 / 85 55 20 Fax: +43 (0) 2252 / 488 60	<b>AUSTRIA</b>	
	MPL Technology Sp. z o.o. ul. Wroclawska 53 <b>PL-30-011 Kraków</b> Telefon +48 (0) 12 / 632 28 85 Fax: +48 (0) 12 / 632 47 82	<b>POLAND</b>	
	Mitsubishi Electric Europe B.V. 12/1 Goncharnaya St, suite 3C <b>RUS-109240 Moscow</b> Telefon +7 (0) 95 / 915-8624/02 Fax: +7 (0) 95 / 915-8603	<b>RUSSIA</b>	